

# INVERTER TYPE R107

# R SERIES

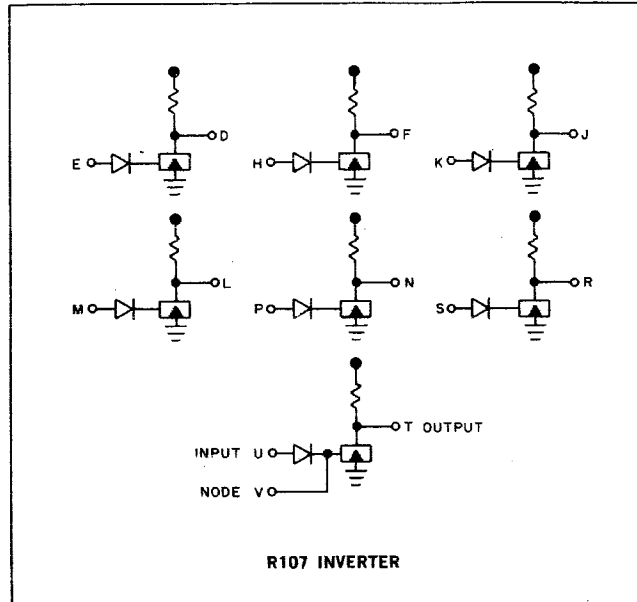

The R107 Inverter contains seven inverter circuits with single-input diode gates. Six of the circuits are used for single-input inversion; the seventh circuit can be used for gating by tying additional diode input networks to its node terminal. Clamped load resistors of 2 ma are a permanent part of each inverter.

**INPUT: Diode** — Standard levels of  $-3v$  and ground, 100-nsec minimum duration. Input load is 1 ma, shared among the inputs that are at ground. **Node Terminal** — Accepts only R001 or R002 Diode Networks or their equivalent. The combined length of all leads attached to the node terminal must not exceed 6 in. Input signal and load characteristics for diode networks are the same as those given for the diode input above.

**OUTPUT:** Standard levels of  $-3v$  and ground. Each inverter can drive 18 ma of load at ground. Output terminals of inverters may be connected in parallel. Some typical propagation delays are shown below. High frequency logic designs may benefit from the application note "Estimating Propagation Delays."

Fan-out	4	10	16
Output Rise	30 nsec	35 nsec	40 nsec
Output Fall	60 nsec	100 nsec	140 nsec

**POWER:** + 10 v(A)/0.7 ma,  $-15 v(B)$ /30 ma.