

MM8/I Replacement	
TITLE: H05X	
Document Number: Logic	REV:
Date: 6/10/2024 5:49:58 PM	Sheet: 1/3

DECPROT011111

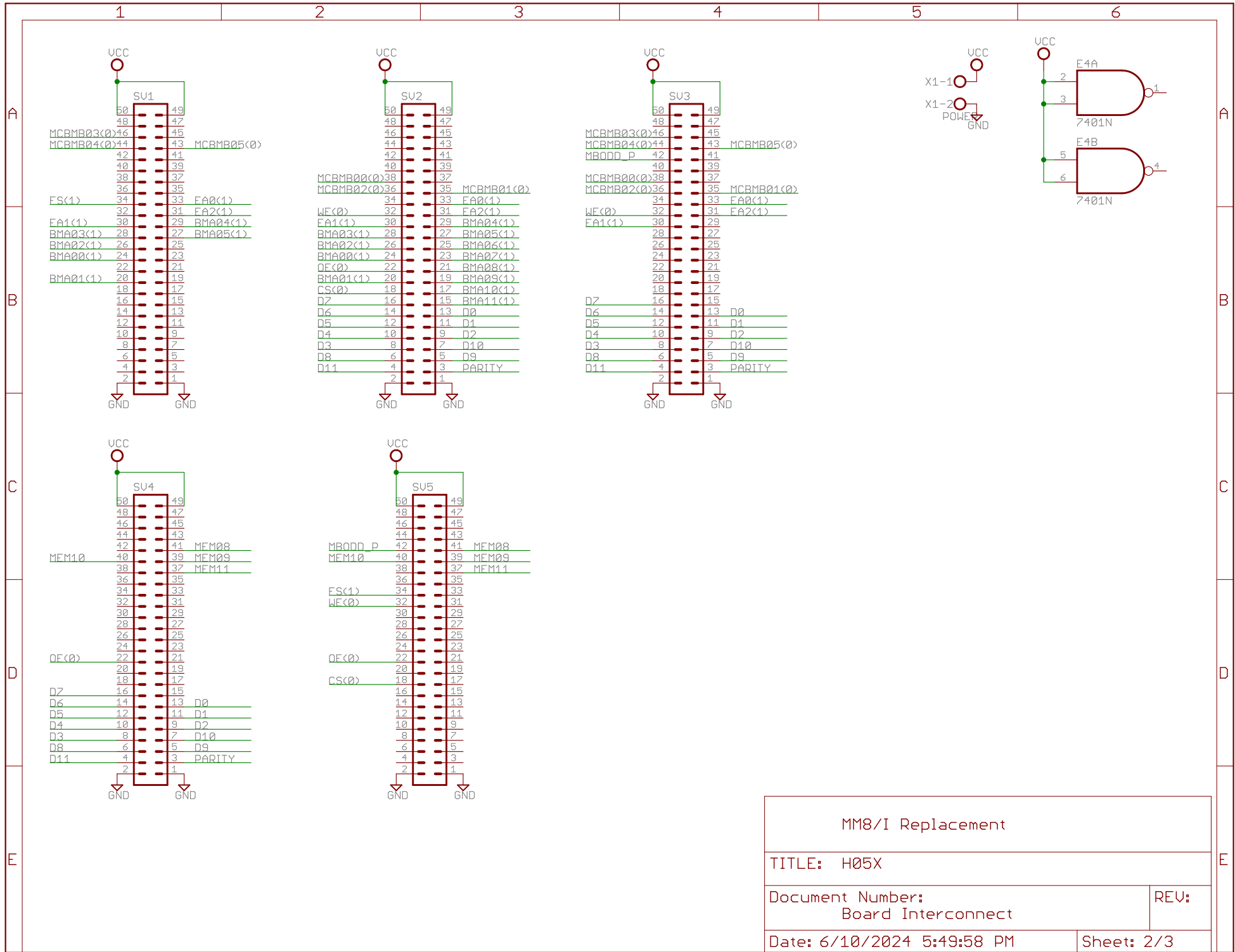

MM8/I Replacement	
TITLE: H05X	
Document Number: Board Interconnect	REV:
Date: 6/10/2024 5:49:58 PM	Sheet: 2/3

1

2

3

4

5

6

A

A

MM8I Notes:

The CPU initiates a read-modify-write cycle with a MEM_START pulse.
 150 ns later MEM_BEGIN sets at the beginning of READ.
 150 ns or more later STROBE is sent when the CPU should grab the READ data.
 350 ns later, READ ends.
 50 ns after TP2, INHIBIT begins.
 100 ns after TP2, WRITE is asserted.
 400 ns after WRITE begins, WRITE ends and MEM_DONE is sent to the CPU.
 Lowercase signifies a local signal, not used by the CPU.

B

B

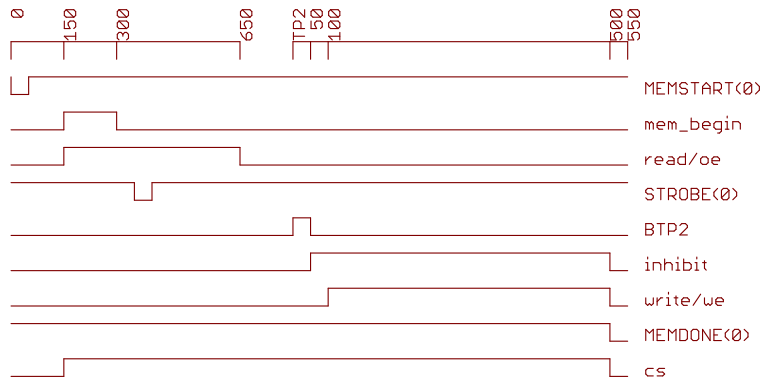

C

C

D

D

E

E

MM8/I Replacement	
TITLE: H05X	
Document Number: Notes	REV:
Date: 6/10/2024 5:49:58 PM	Sheet: 3/3