

In this drawing:

- 1 Notes and Table of Contents
- 2 D-BS-8i-0-2 Timing, Manual Functions and Run (1/2)
- 3 D-BS-8i-0-2 Timing, Manual Functions and Run (2/2)
- 4 D-BS-8i-0-3 Instruction Register and Major States
- 5 D-BS-8i-0-4 Register Output Gate Control
- 6 D-BS-8i-0-5 Shift and Carry Gate Control
- 7 D-BS-8i-0-6 Register Input Control and Skip
- 8 D-BS-8i-0-7 Interrupt and Break Control
- 9 D-BS-8i-0-8 Major Registers
- 10 D-BS-8i-0-9 Major Registers Gating (1/4)
- 11 D-BS-8i-0-9 Major Registers Gating (2/4)
- 12 D-BS-8i-0-9 Major Registers Gating (3/4)
- 13 D-BS-8i-0-9 Major Registers Gating (4/4)
- 14 D-BS-8i-0-10 I/O Level Converter
- 15 D-BS-8i-0-11 Teletype Receivers
- 16 D-BS-8i-0-12 Teletype Transmitter
- 17 D-BS-8i-0-13 Memory Control
- 18 D-BS-8i-0-14 Sense Amps and Inhibit Drivers
- 19 D-BS-8i-0-15 X Axis Selection
- 20 D-BS-8i-0-16 Y Axis Selection
- 21 D-BS-mc8i-0-1 Memory Extension Control (1/2)
- 22 D-BS-mc8i-0-1 Memory Extension Control (2/2)
- 23 D-BS-mc8i-0-2 Inhibit Drivers
- 24 D-BS-mc8i-0-3 X Axis Selection
- 25 D-BS-mc8i-0-4 Y Axis Selection
- 26 D-BS-kt8i-0-1 Time-share Option
- 27 D-BS-ke8i-0-2 EAE Control
- 28 D-BS-ke8i-0-3 Multiplier Quot. and Step Counter
- 29 D-BS-dl8i-0-2 Data Line Interface
- 30 D-BS-mp8i-0-1 Memory Parity Option (1/2)
- 31 D-BS-mp8i-0-1 Memory Parity Option (2/2)
- 32 D-BS-kp8i-0-1 Power Fail and Restart Option
- 33 D-BS-vc8i-0-1 Display Control
- 34 D-BS-vp8i-0-1 Plotter Control
- 35 D-BS-pp8i-0-1 High Speed Punch
- 36 D-BS-pr8i-0-1 High Speed Reader
- 37 D-BS-kw8i-0-1 Real Time Clock Option
- 38 D-BS-cr8i-0-2 Card Reader Control #1
- 39 D-BS-cr8i-0-3 Card Reader Control #2
- 40 Unused

Must tie either S or S₊ to GND if no DL8i
Need a proper jumper list for dl8i, like those below.

EAE Disable Jumpers (blue wire wrap):
(from Dave Gesswein)

- E28L1 to GND EAE_L_DISABLE
- F23H2 to +3 volts EAE_E_SET
- F24C1 to +3 volts EAE_NO_SHIFT_ENABLE
- F28R1 to +3 volts EAE_ON
- F31D2 to +3 volts EAE_MEM_ENABLE
- F33P2 to GND B EAE_ON
- F39F1 to GND. MQ_ENABLE
- F39F2 to GND. SC_ENABLE

KT8I Disable Jumpers (blue wire wrap):
(from Dave Gesswein)

- E13D1 to E15M2, UF(0) to +3V
- E18U1 to B4V1 SKIP ored to SKIP(1)
- F11M2 (or possibly F11H2 or F11N2) to F11U1, CUF to +3V
- F19N1 to F19N2 UINT to +3V
- J13U2 to H13P2 ME5 to +3V

Unused Slots:

- | | |
|-----|-----|
| E03 | H06 |
| E04 | F04 |
| E05 | F05 |
| E06 | F06 |
| E07 | F07 |
| E08 | H35 |
| | H36 |
| | H37 |
| | H38 |
| | H39 |
| | H40 |
| | J21 |
| | J22 |
| | H33 |
| | J35 |
| | J36 |
| | J37 |
| | J38 |
| | J39 |
| | J40 |

BUGBUG: TP4 seems hopelessly overloaded, given that clock inputs are 2 standard TTL loads.

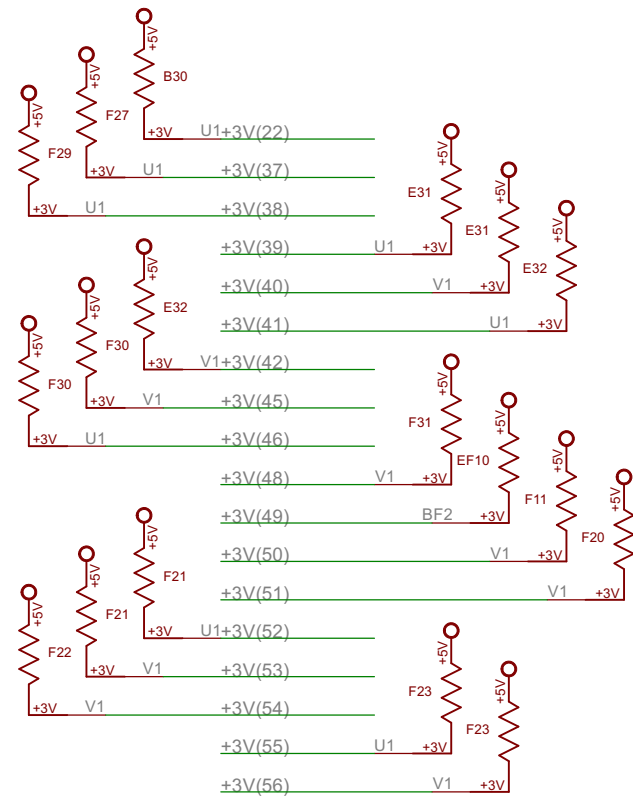

BUGBUG: This was done based on proximity, ignoring issues of authenticity. (Fanout has been checked.)



This kludge added by VRS, since IO_PC_LOAD isn't driven.
This signal was added by an ECO, but lacks a driver.
I've added a connector pin here, for now.

ECOs Believed to be Integrated:

- 8i-00001
- 8i-00002
- 8i-00009
- 8i-00013
- 8i-00015
- 8i-00020
- 8i-00021
- 8i-00025
- 8i-00029
- 8i-00034
- 8i-00042
- 8i-00046
- 8i-00050
- 8i-00054 Buffer MEM_START and TP2.
- 8i-00059
- 8i-00067
- 8i-00069
- 8i-00071
- 8i-00081
- 8i-00084
- 8i-00085 Delay TP3 50ns so slow MM can meet set up for adder.
- 8i-00086

Other ECOs Known to Exist:

- 8i-00024 D-MU-8i-0-16 Module Utilization
- 8i-00026 D-CS-8i-0-27 Console switches and Indicators
- 8i-00032 D-MU-8i-0-16 Module Utilization
- 8i-00052 D-MU-8i-0-17 Module Utilization
- 8i-00068 D-MU-8i-0-17 Module Utilization
- 8i-00093 D-MU-8i-0-17 Module Utilization
- 8i-00096 D-MU-8i-0-17 Module Utilization
- 8i-00099 D-MU-8i-0-17 Module Utilization



Notes and Table of Contents

TITLE: pdp8i-dec

Document Number:

REV:

Date: 2/22/2021 2:11:40 AM

Sheet: 1/40

For the ka8i the I/O strobe delay line tap is changed from pin F12T2 to F12V2 to increase delay to 0.5us. This may be an issue for non-wire-wrap-backplanes.

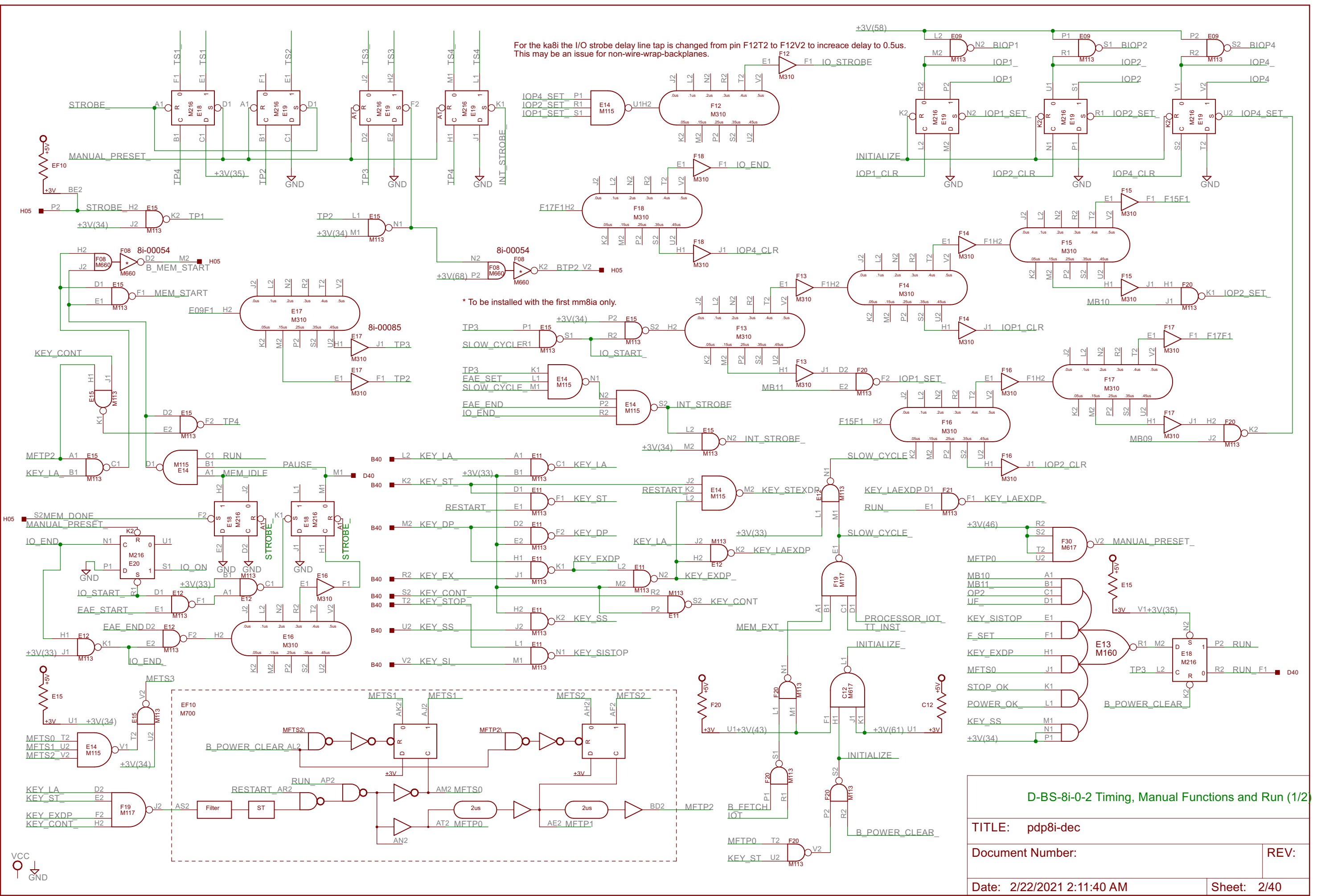

D-BS-8i-0-2 Timing, Manual Functions and Run (1/2)	
TITLE: pdp8i-dec	
Document Number:	REV:
Date: 2/22/2021 2:11:40 AM	Sheet: 2/40



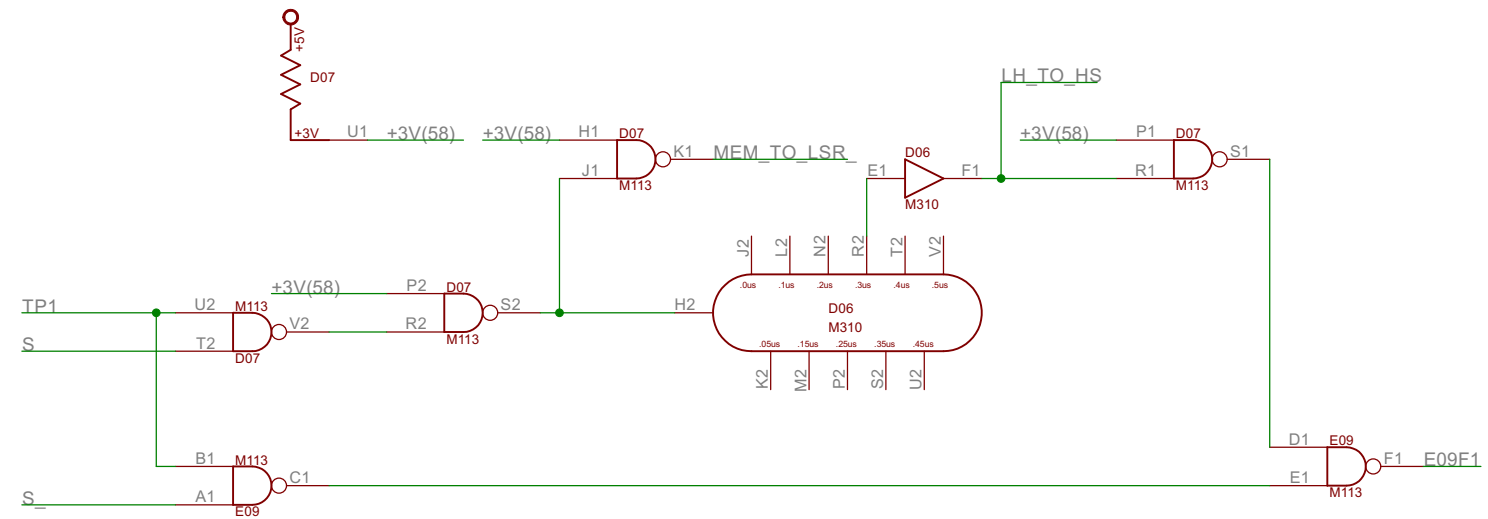

VCC
 GND

D-BS-8i-0-2 Timing, Manual Functions and Run (2/2)

TITLE: pdp8i-dec

Document Number:

REV:

Date: 2/22/2021 2:11:40 AM

Sheet: 3/40

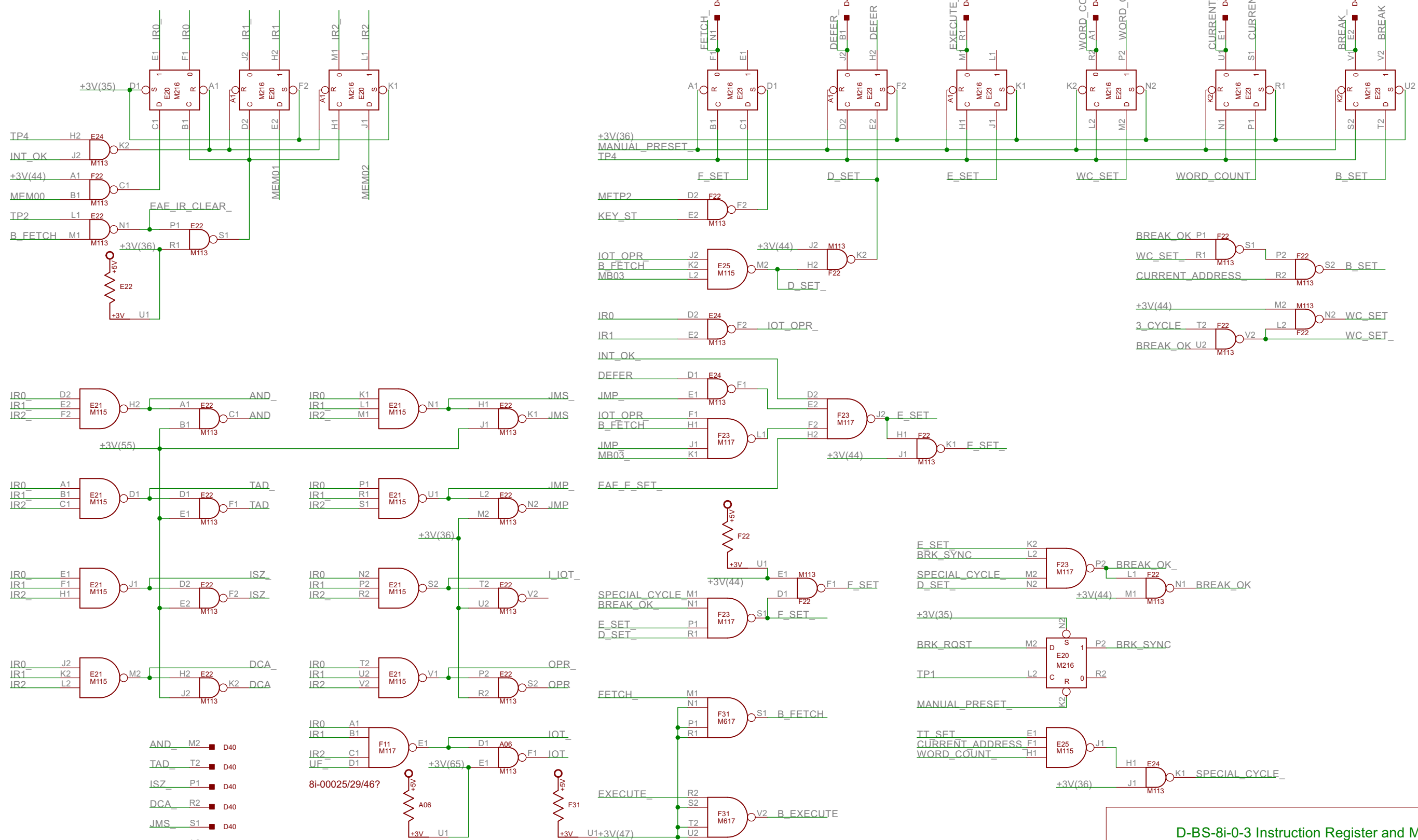

- AND_ M2 ■ D40
- TAD_ T2 ■ D40
- ISZ_ P1 ■ D40
- DCA_ R2 ■ D40
- JMS_ S1 ■ D40
- JMP_ L2 ■ D40
- IOT_ H2 ■ D40
- OPR_ D2 ■ D40

8i-00025/29/46?

D-BS-8i-0-3 Instruction Register and Major States	
TITLE: pdp8i-dec	
Document Number:	REV:
Date: 2/22/2021 2:11:40 AM	Sheet: 4/40



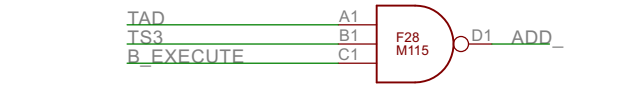
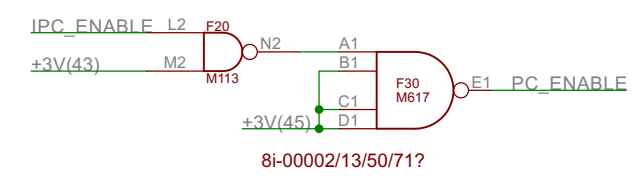
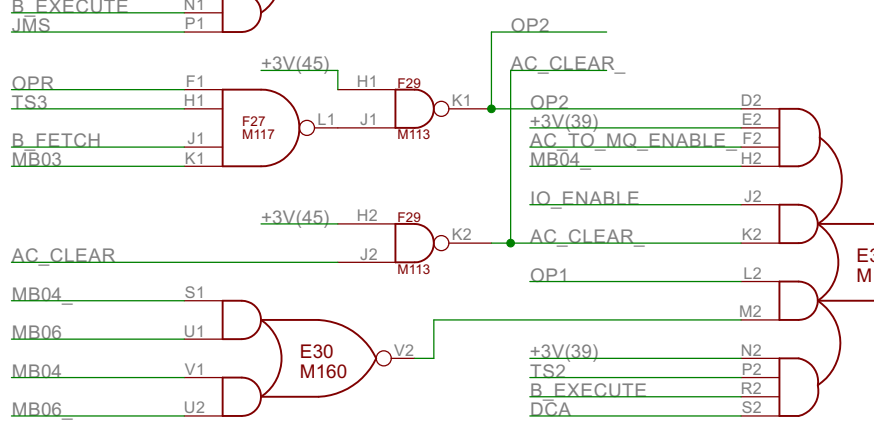
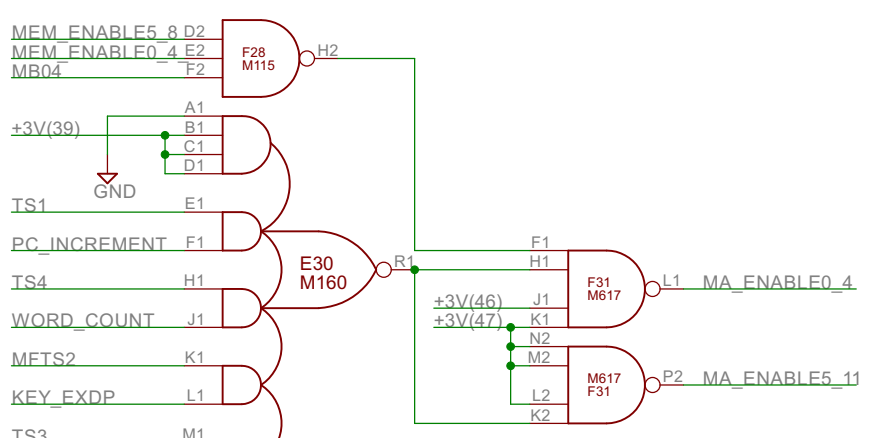
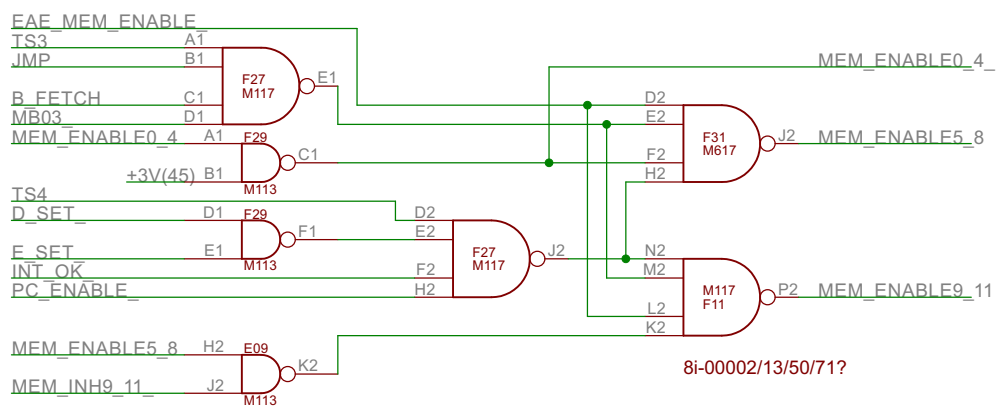
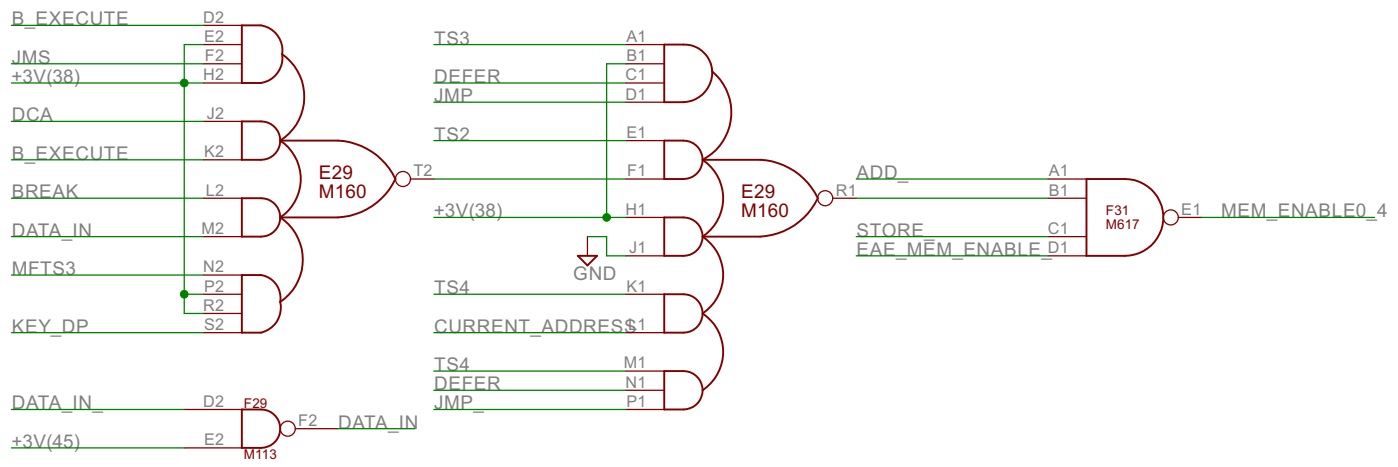
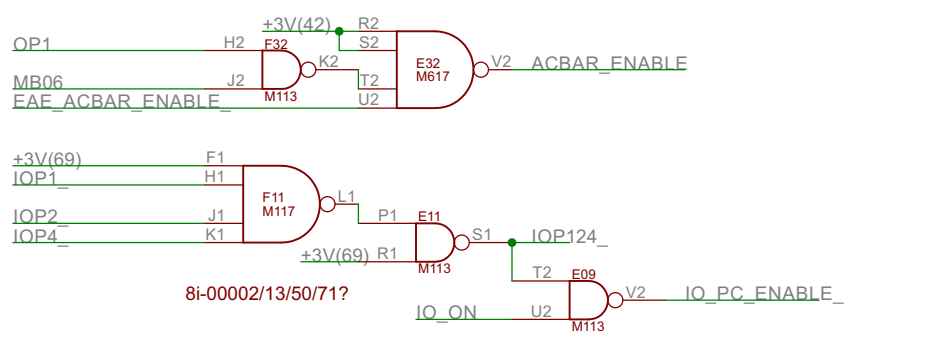
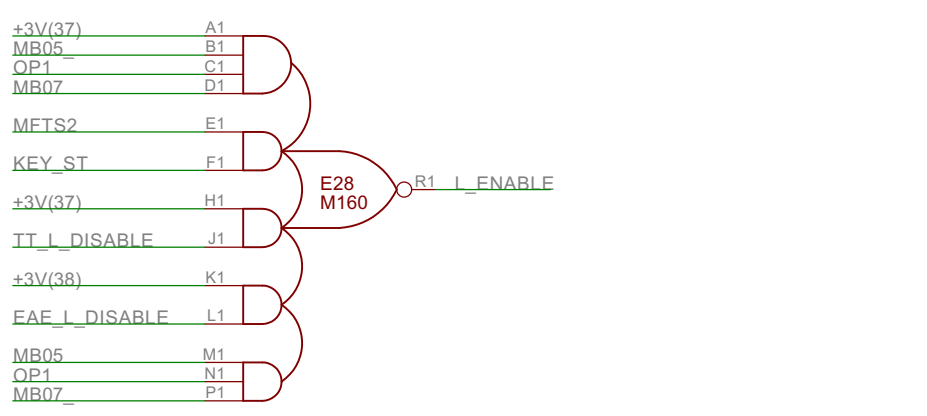
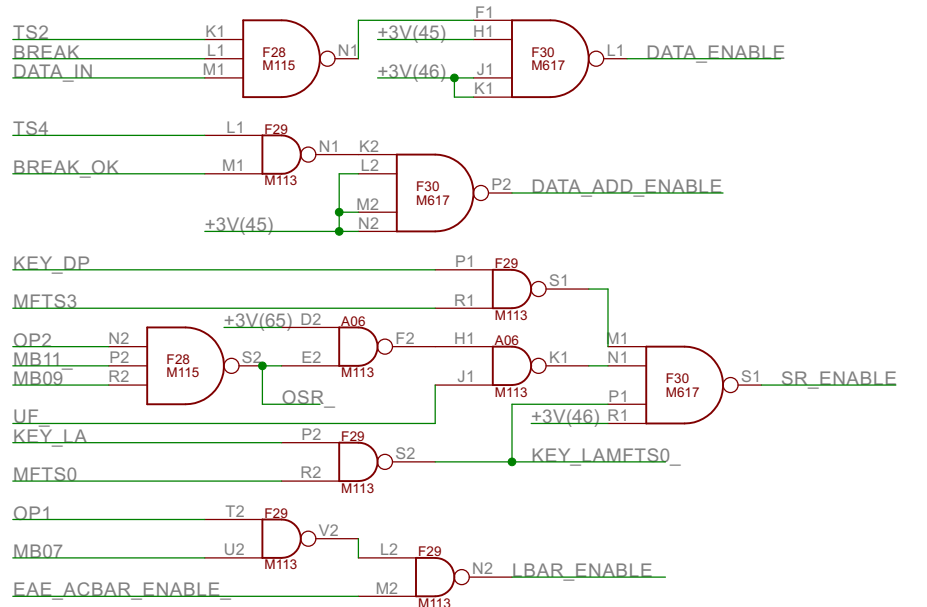
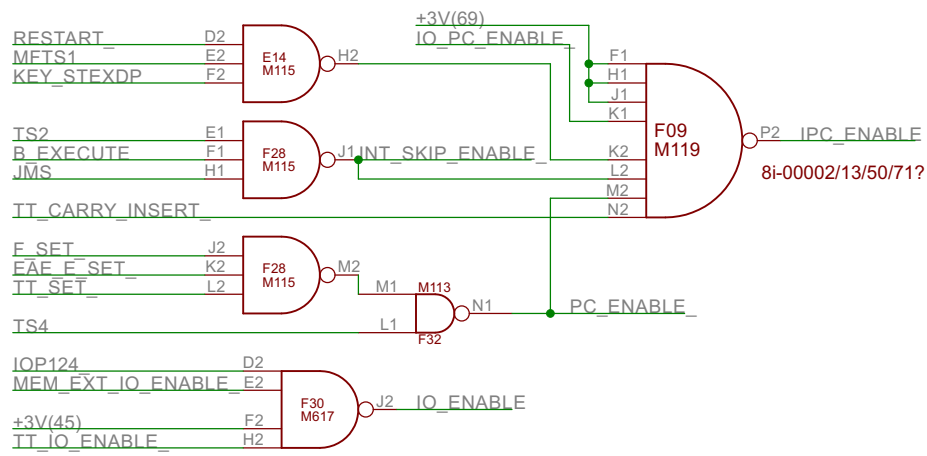

D-BS-8i-0-4 Register Output Gate Control

TITLE: pdp8i-dec		REV:
Document Number:		
Date: 2/22/2021 2:11:40 AM	Sheet: 5/40	

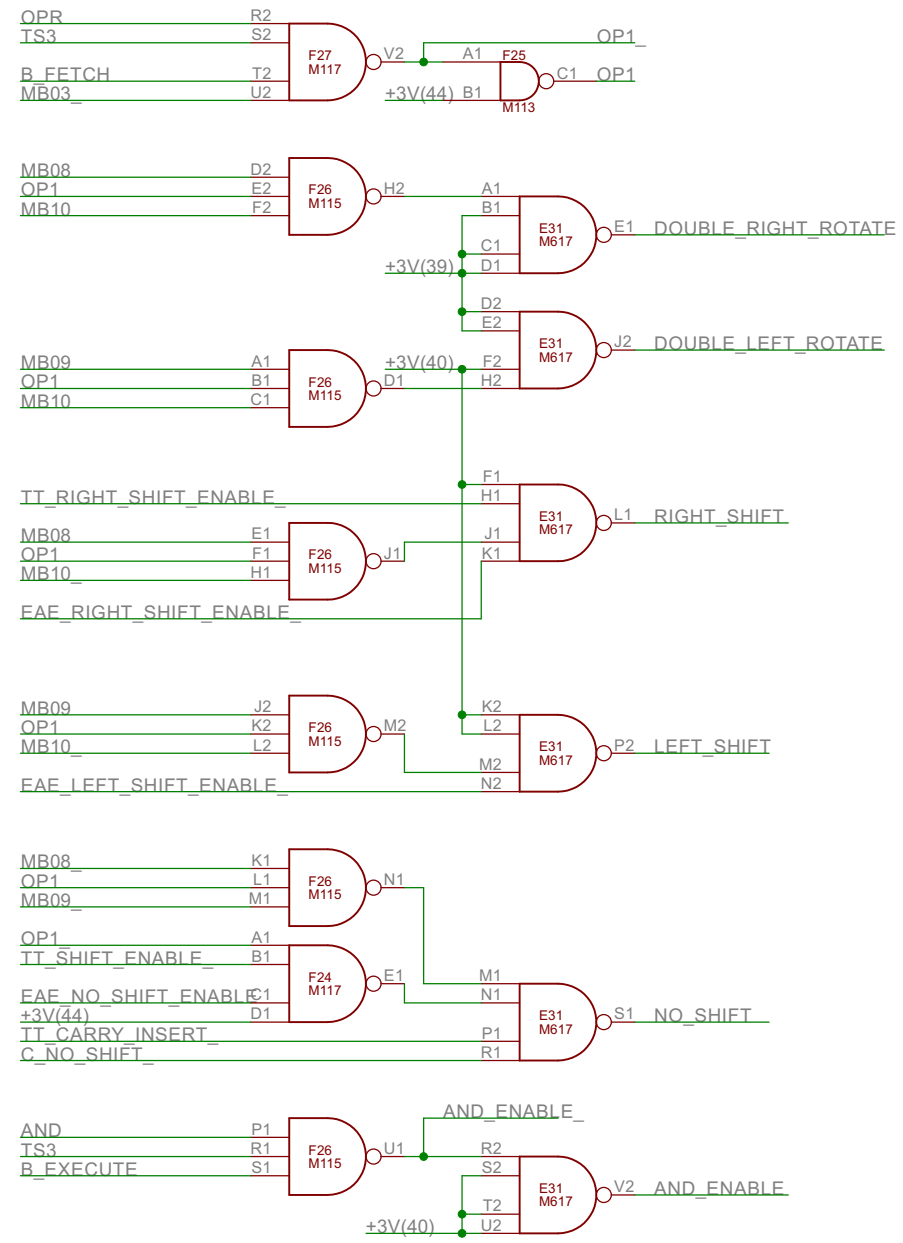
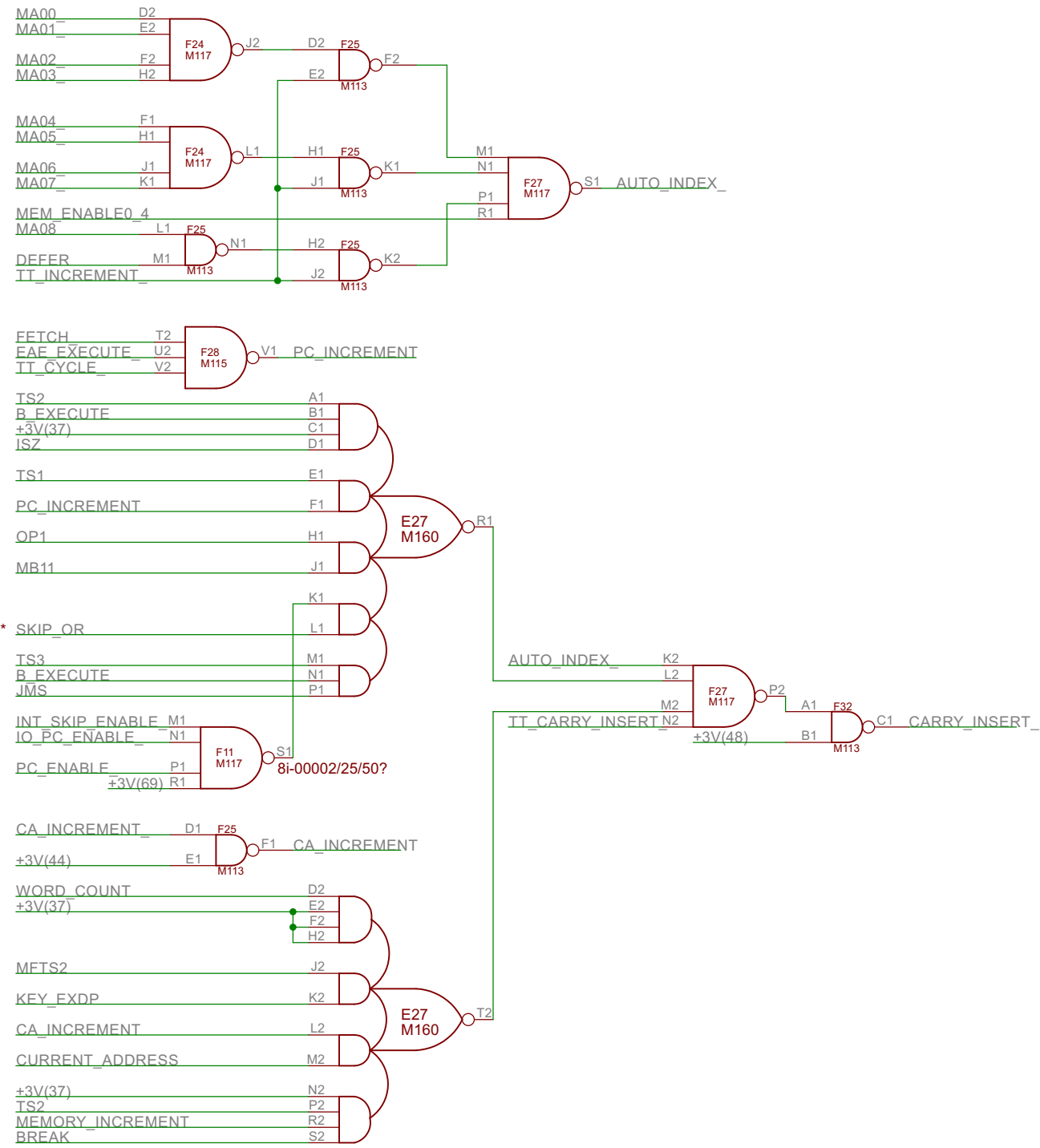

* If no kt8i installed, SKIP_OR is jumpered to SKIP.
See option jumpers (8i-0-23).



D-BS-8i-0-5 Shift and Carry Gate Control

TITLE: pdp8i-dec

Document Number:

REV:

Date: 2/22/2021 2:11:40 AM

Sheet: 6/40

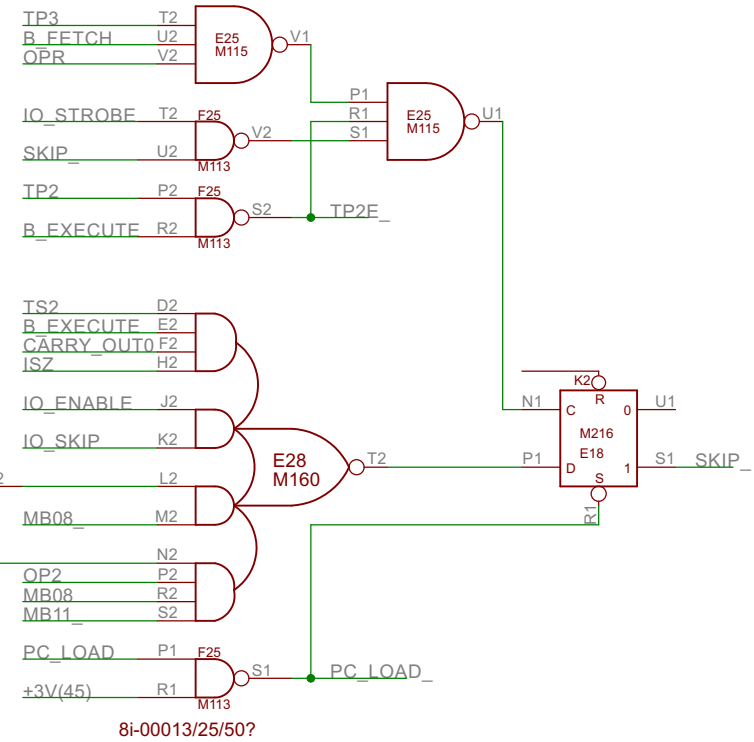
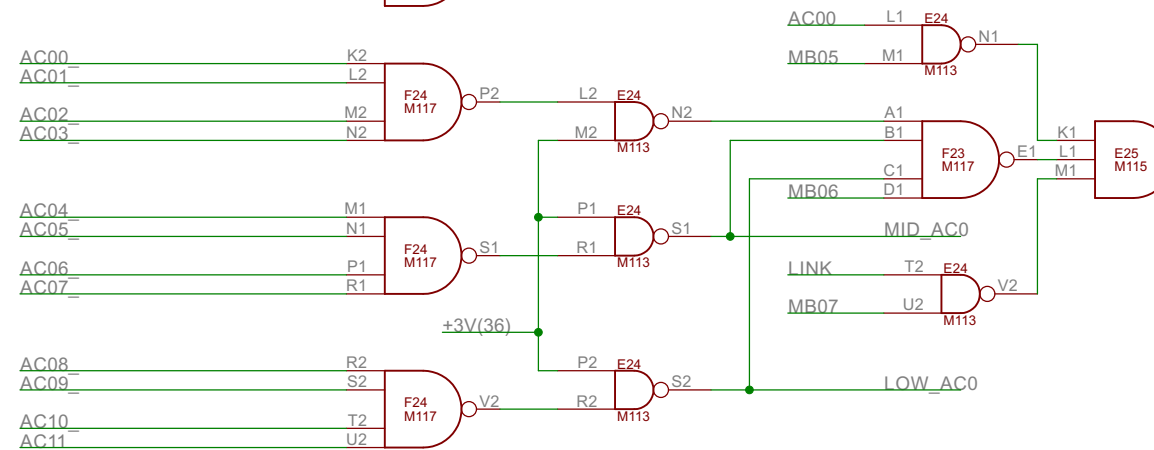
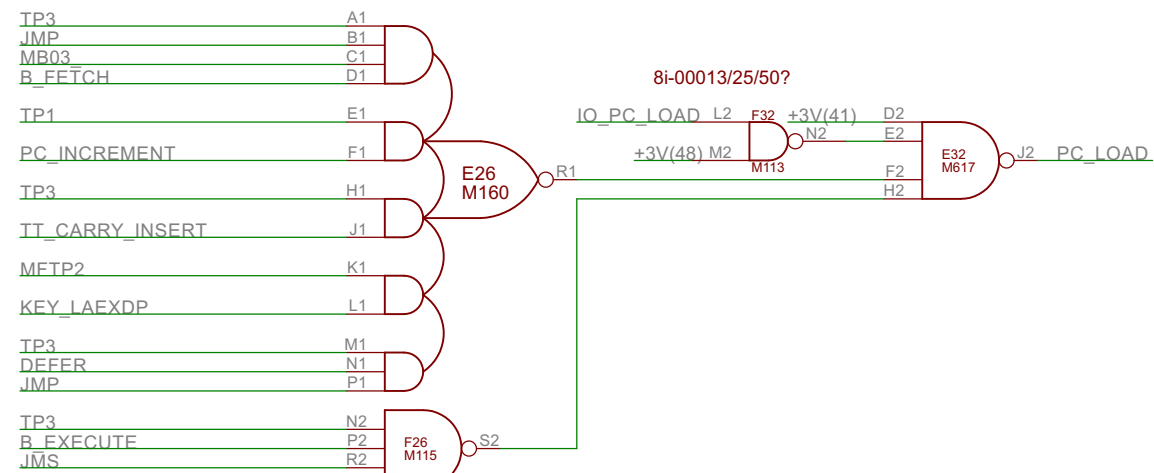
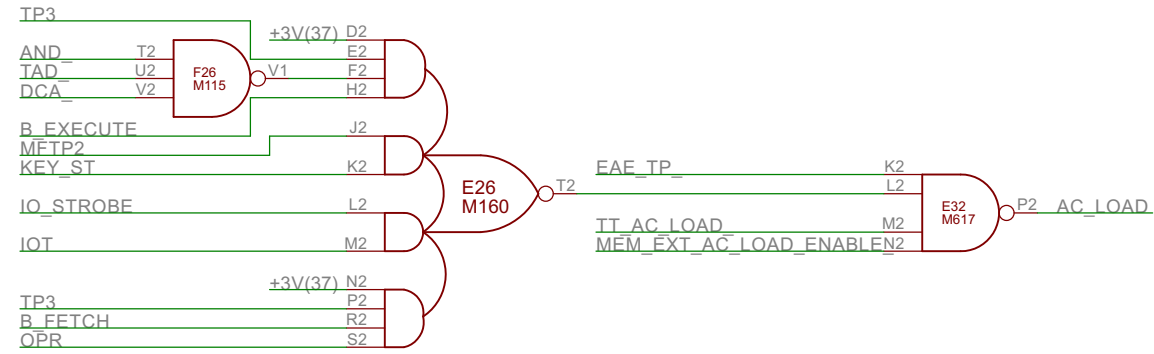
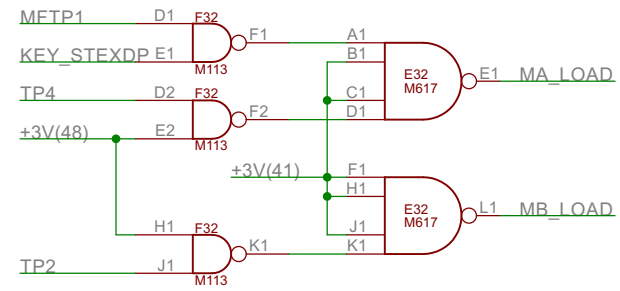

VCC
GND

D-BS-8i-0-6 Register Input Control and Skip

TITLE: pdp8i-dec

Document Number:

REV:

Date: 2/22/2021 2:11:40 AM

Sheet: 7/40

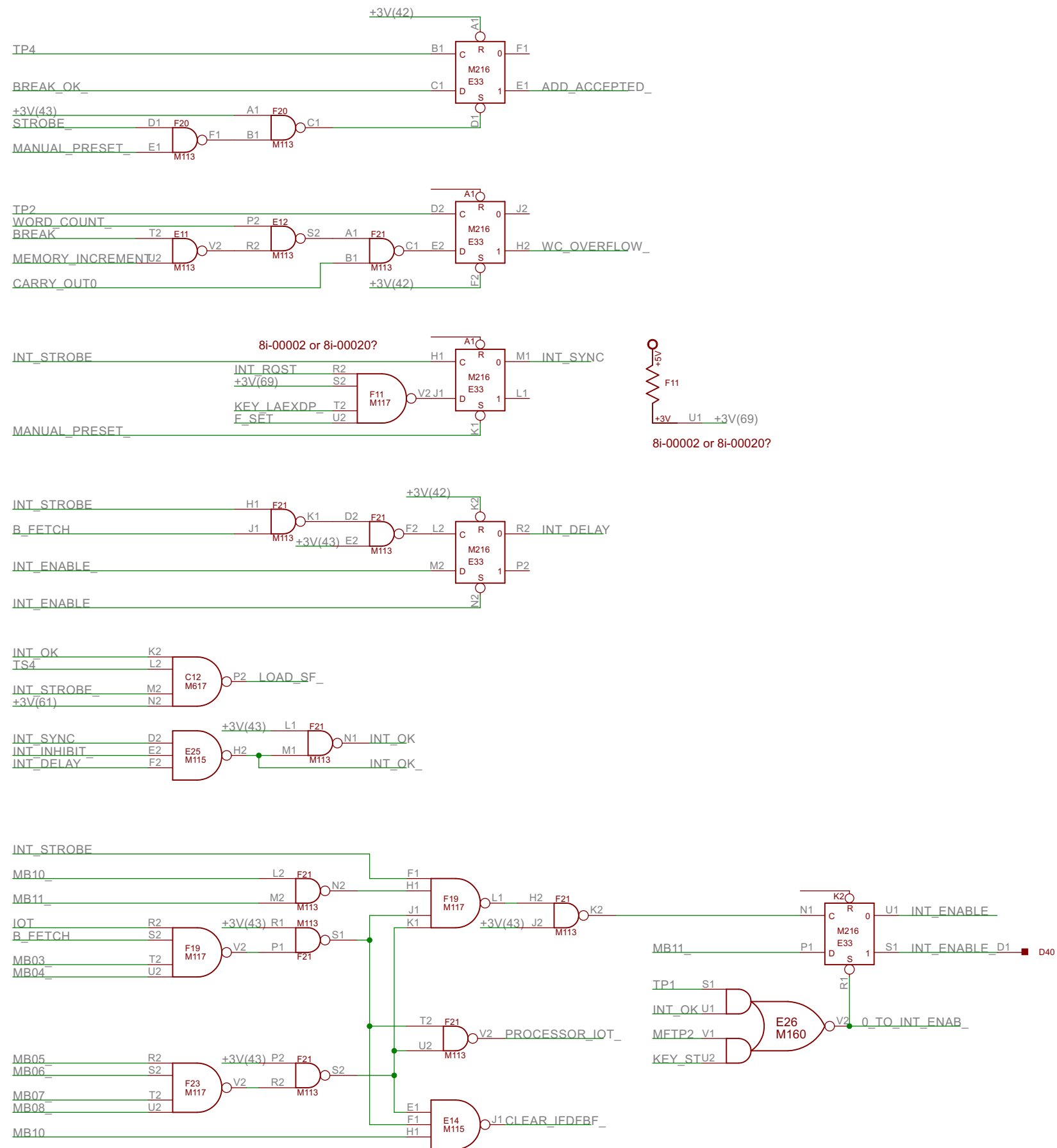

D-BS-8i-0-7 Interrupt and Break Control

TITLE: pdp8i-dec	
Document Number:	REV:
Date: 2/22/2021 2:11:40 AM	Sheet: 8/40

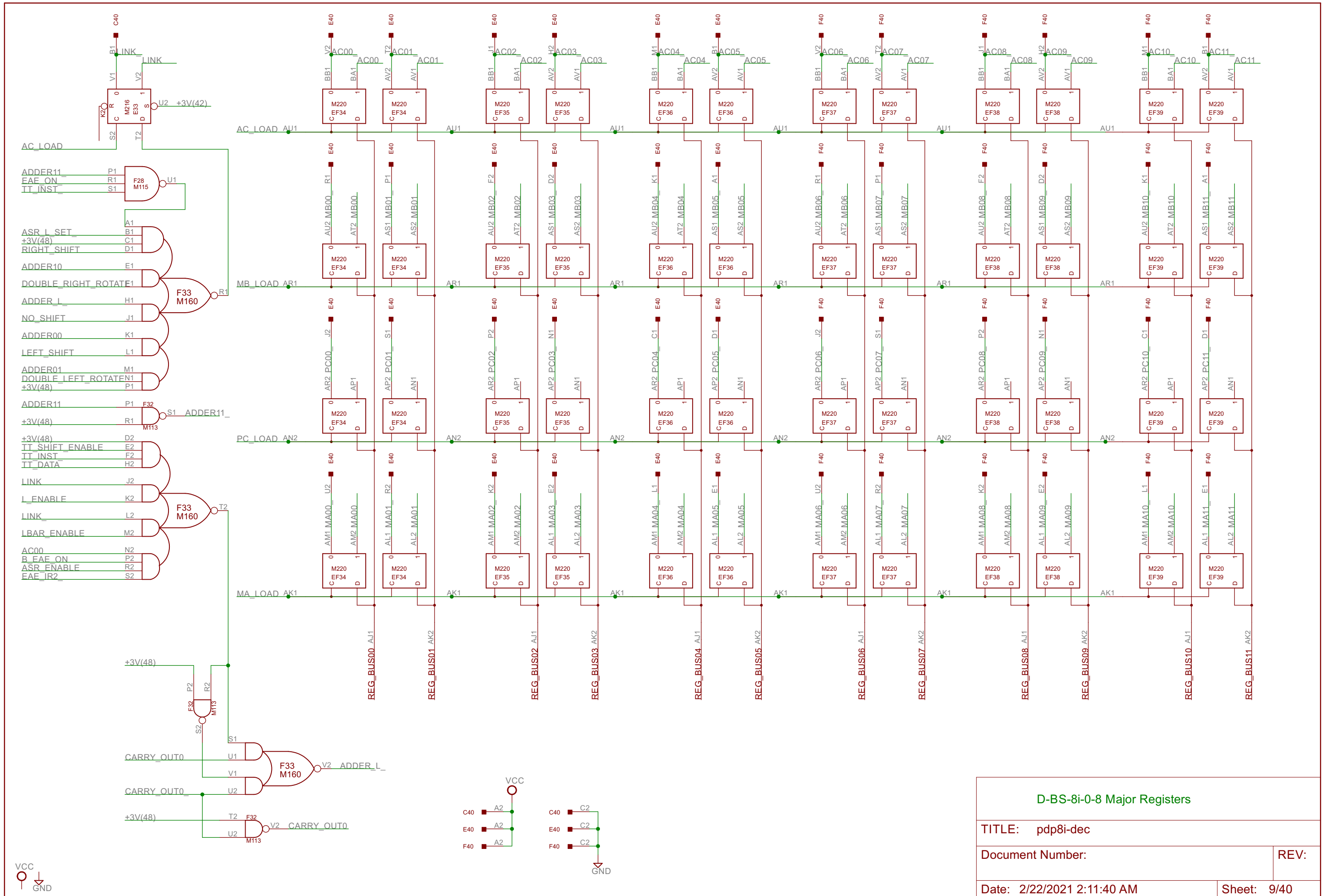

D-BS-8i-0-8 Major Registers

TITLE: pdp8i-dec

Document Number:

REV:

Date: 2/22/2021 2:11:40 AM

Sheet: 9/40

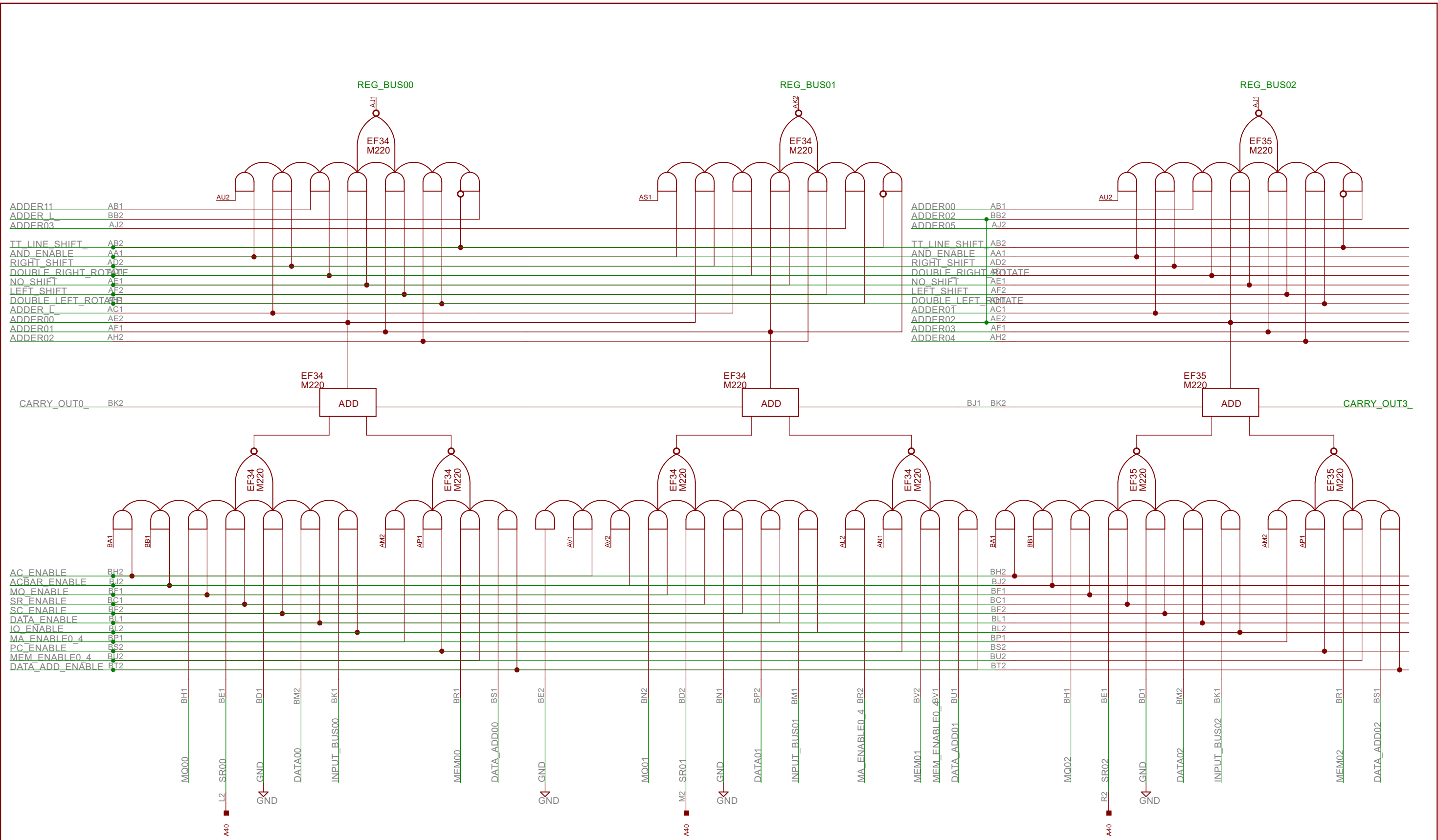

D-BS-8i-0-9 Major Registers Gating (1/4)

TITLE: pdp8i-dec

Document Number:

REV:

Date: 2/22/2021 2:11:40 AM

Sheet: 10/40



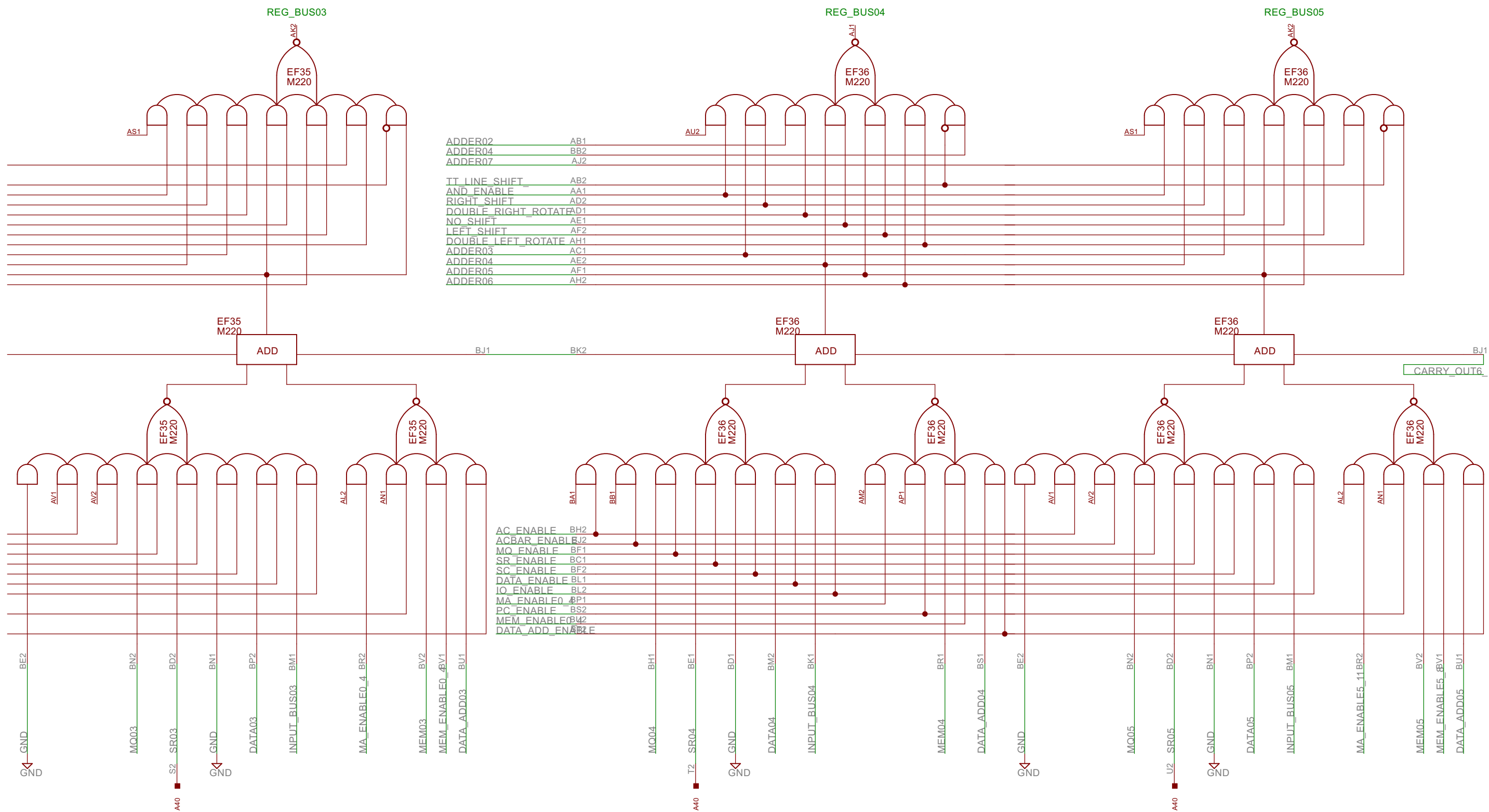

D-BS-8i-0-9 Major Registers Gating (2/4)

TITLE: pdp8i-dec	
Document Number:	REV:
Date: 2/22/2021 2:11:40 AM	Sheet: 11/40

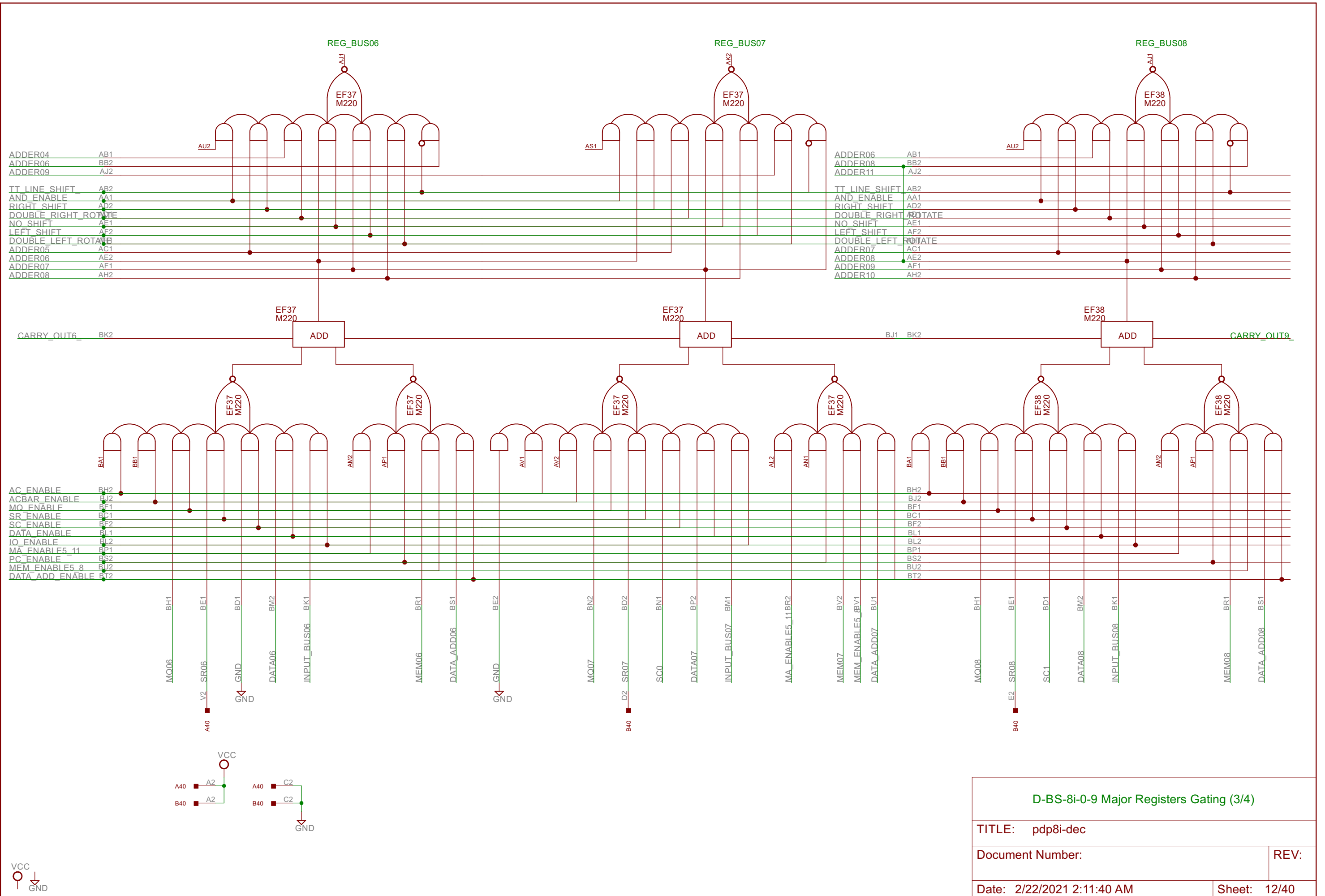

D-BS-8i-0-9 Major Registers Gating (3/4)

TITLE: pdp8i-dec

Document Number:

REV:

Date: 2/22/2021 2:11:40 AM

Sheet: 12/40

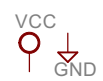

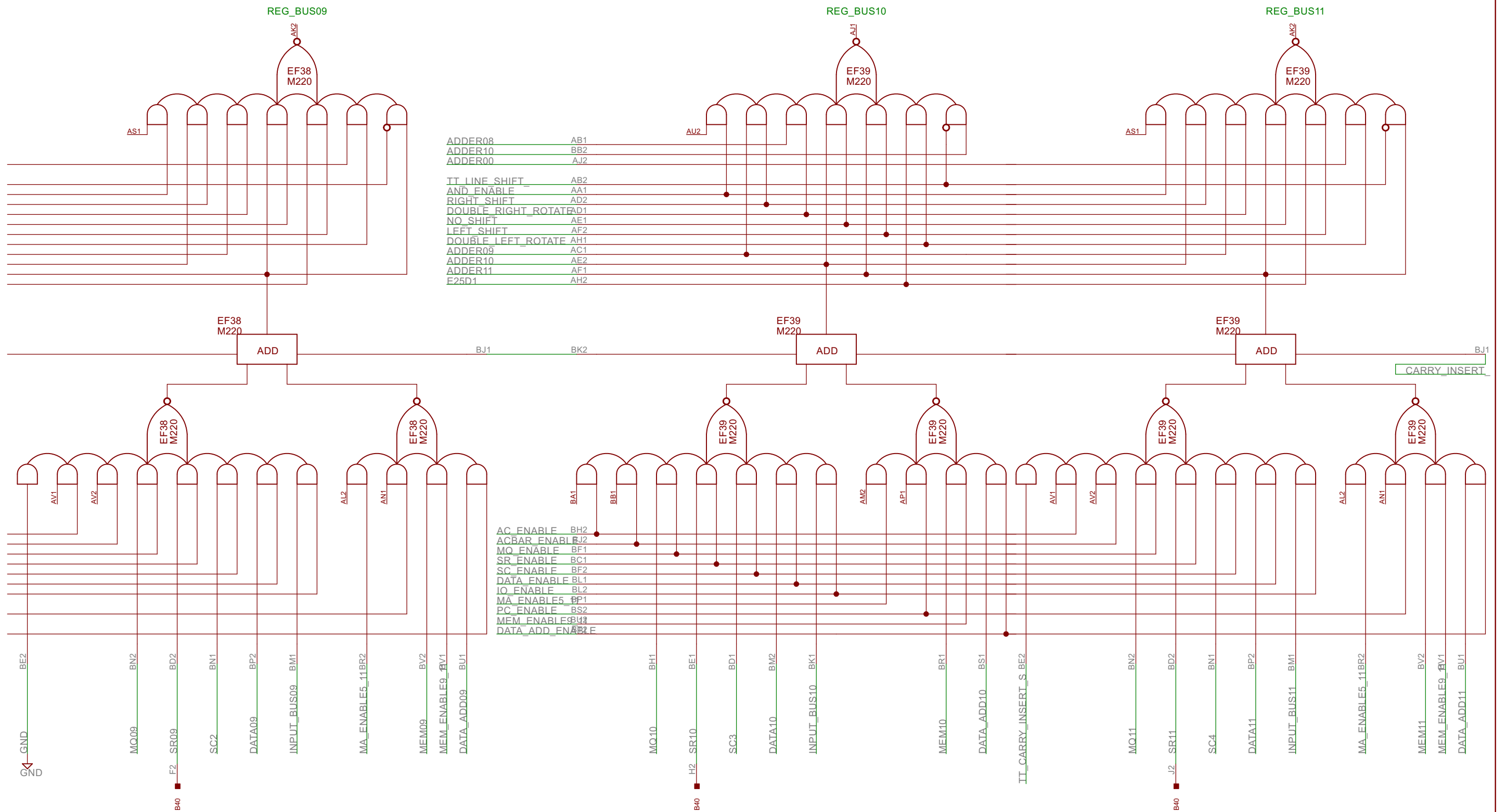

D-BS-8i-0-9 Major Registers Gating (4/4)

TITLE: pdp8i-dec

Document Number:

REV:

Date: 2/22/2021 2:11:40 AM

Sheet: 13/40

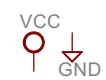

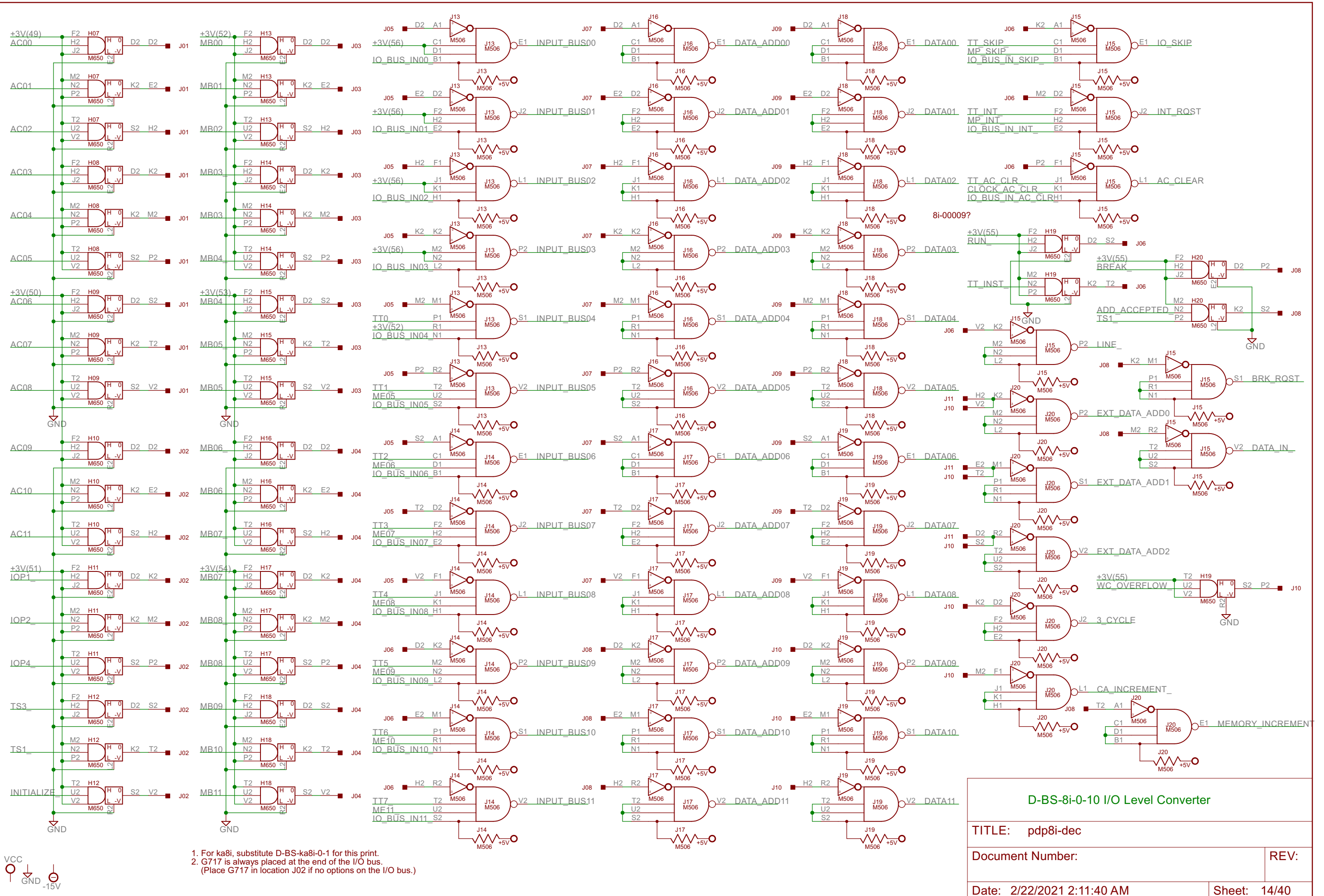

D-BS-8i-0-10 I/O Level Converter

TITLE: pdp8i-dec		REV:
Document Number:		
Date: 2/22/2021 2:11:40 AM	Sheet: 14/40	

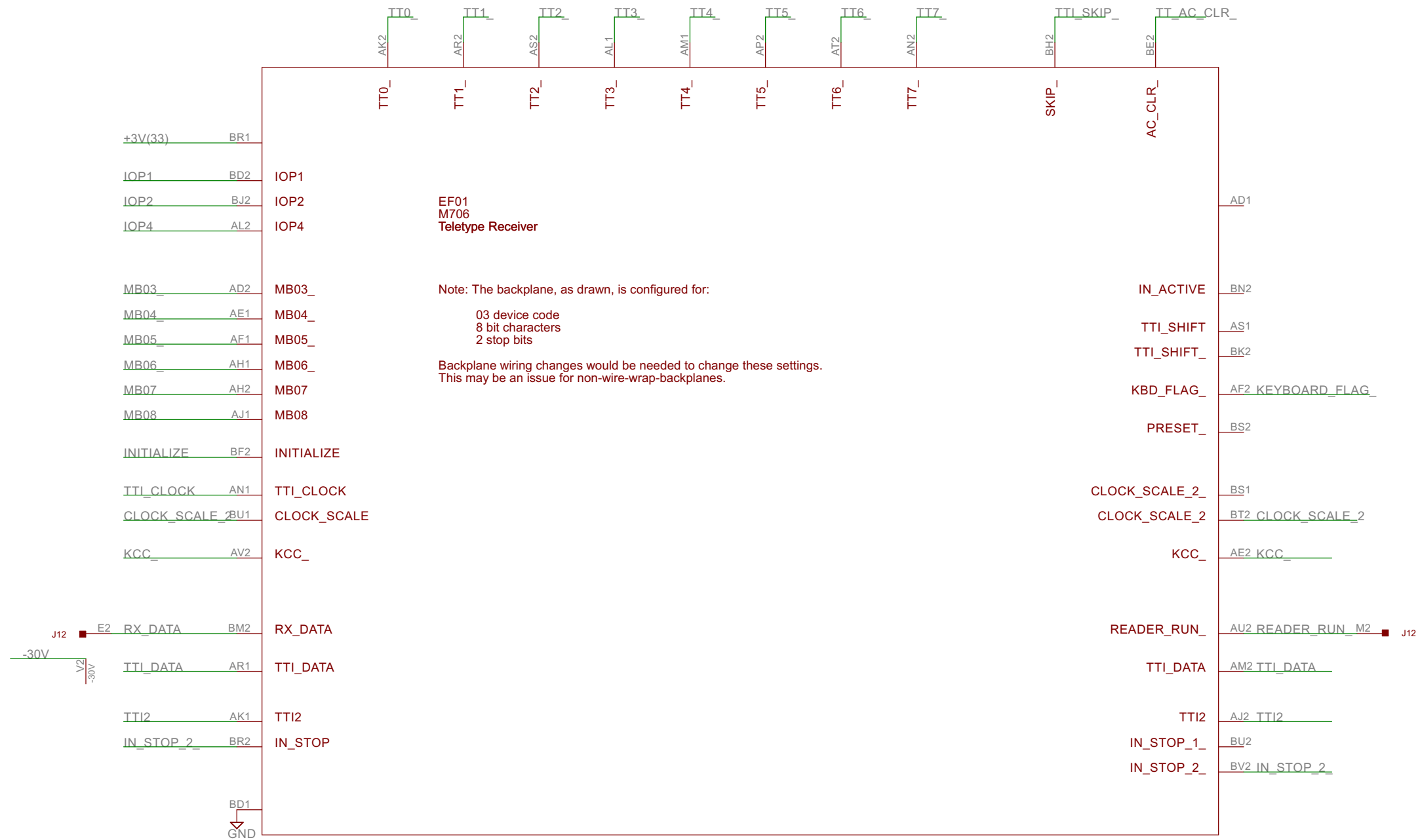

D-BS-8i-0-11 Teletype Receivers

TITLE: pdp8i-dec

Document Number:

REV:

Date: 2/22/2021 2:11:40 AM

Sheet: 15/40

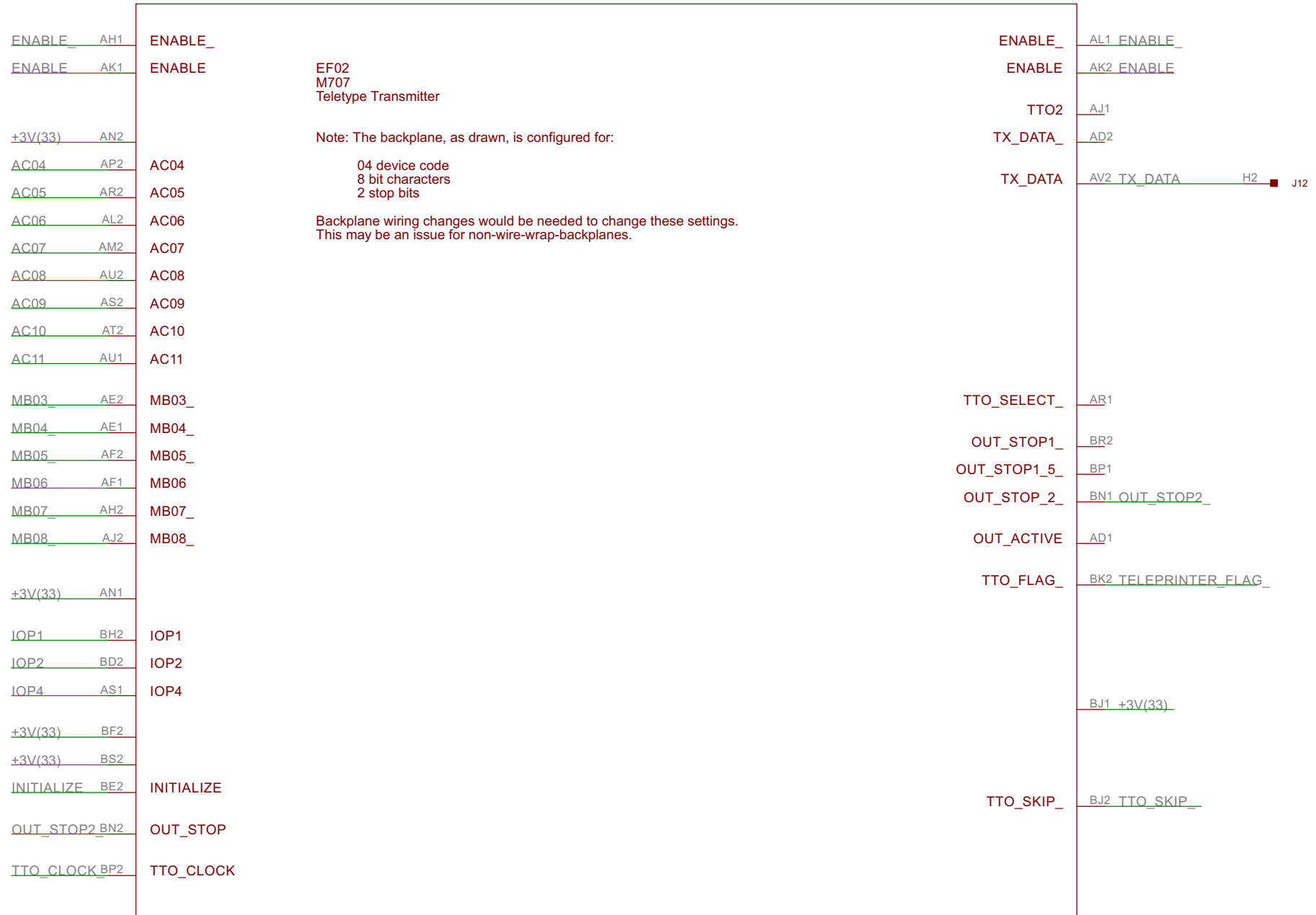
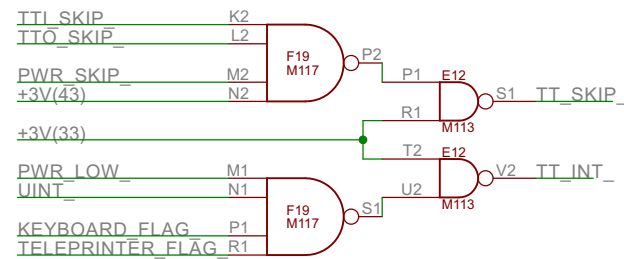
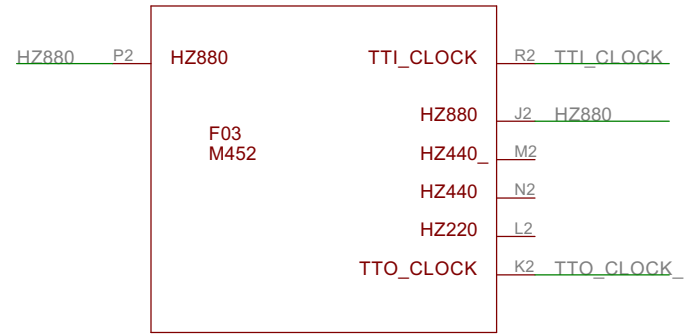

D-BS-8i-0-12 Teletype Transmitter

TITLE: pdp8i-dec

Document Number:

REV:

Date: 2/22/2021 2:11:40 AM

Sheet: 16/40

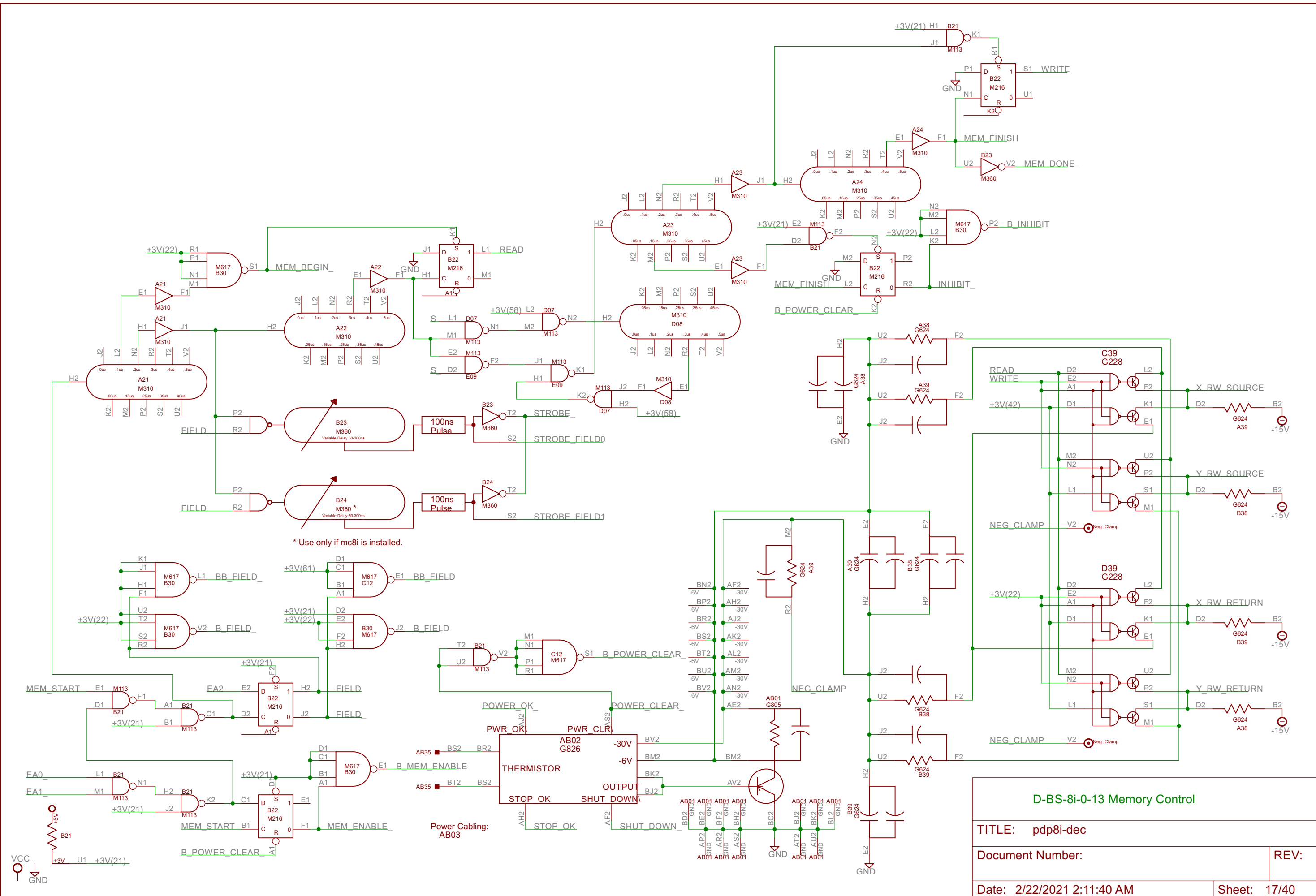

* Use only if mc8i is installed.

D-BS-8i-0-13 Memory Control

TITLE: pdp8i-dec

Document Number:

REV:

Date: 2/22/2021 2:11:40 AM

Sheet: 17/40

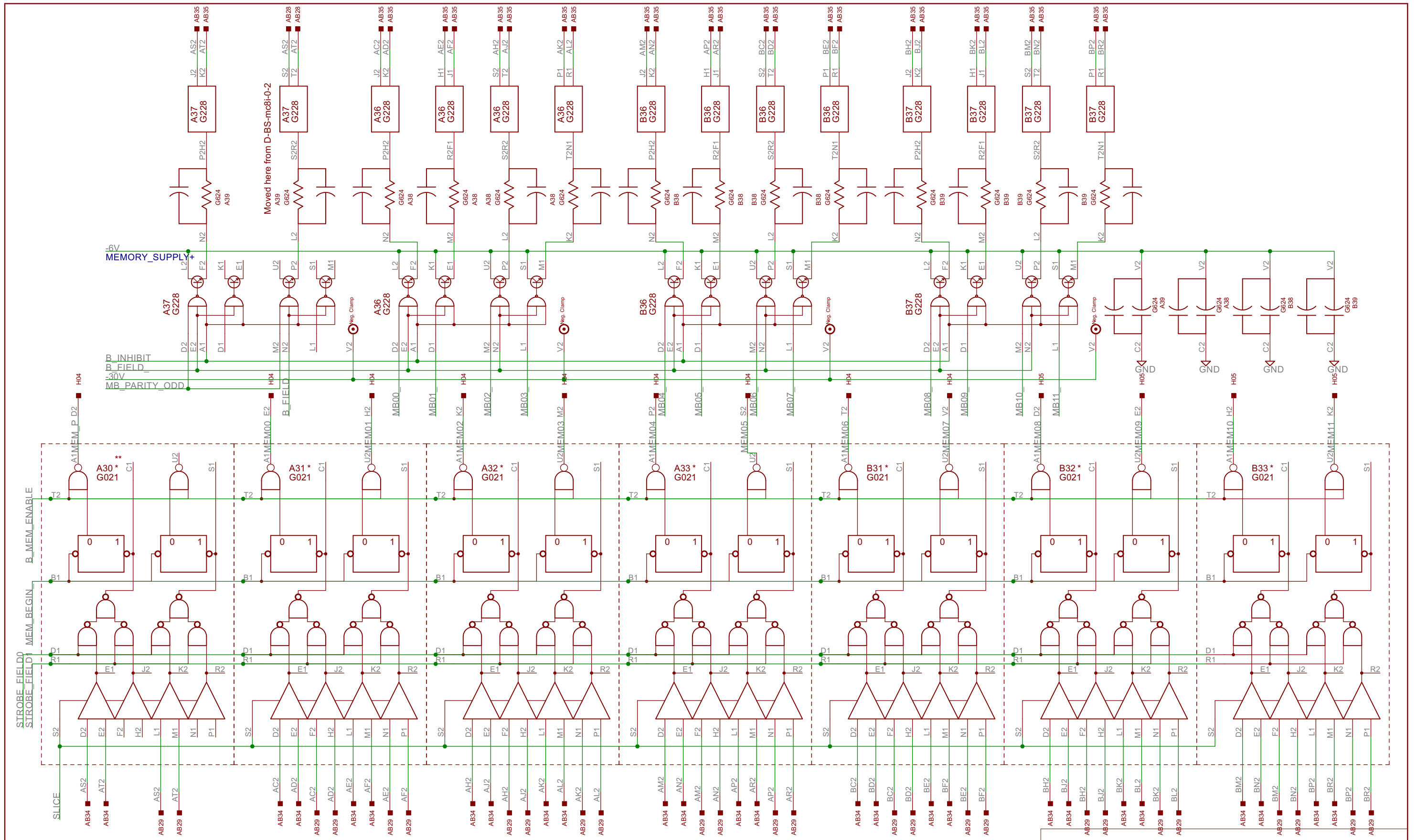

* Use G020 instead of G021 if mc8i is not installed.
 ** Use only with mp8i option.

D-BS-8i-0-14 Sense Amps and Inhibit Drivers

TITLE: pdp8i-dec		REV:
Document Number:		REV:
Date: 2/22/2021 2:11:40 AM	Sheet: 18/40	

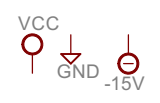

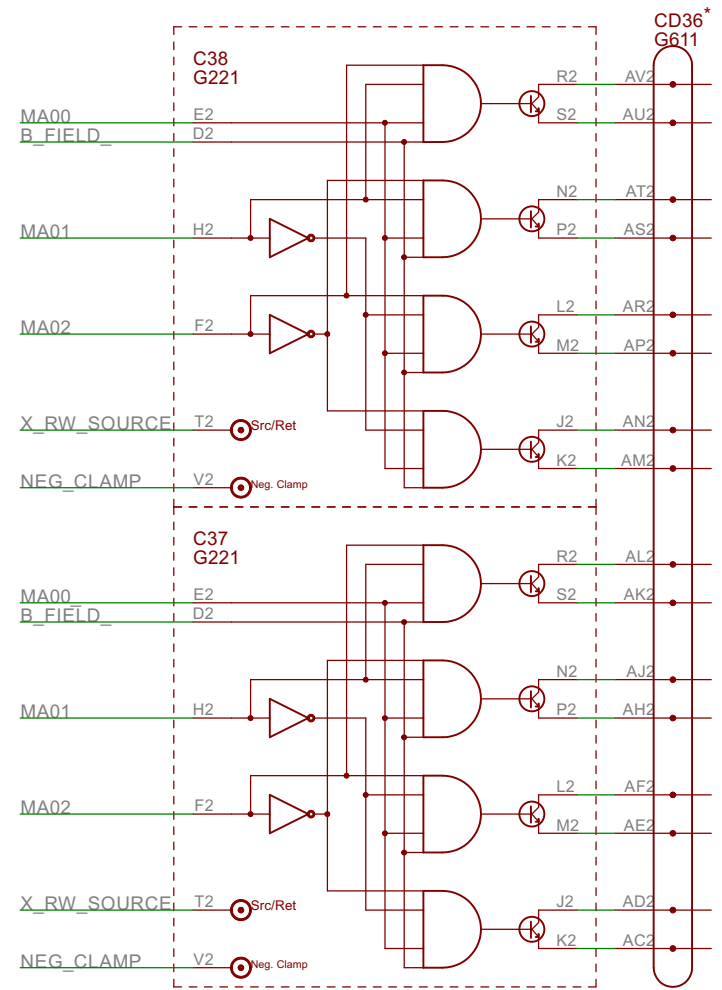

* G611 in CD36 is replaced with G612 for MP8i.

Core Memory:
C35
D35

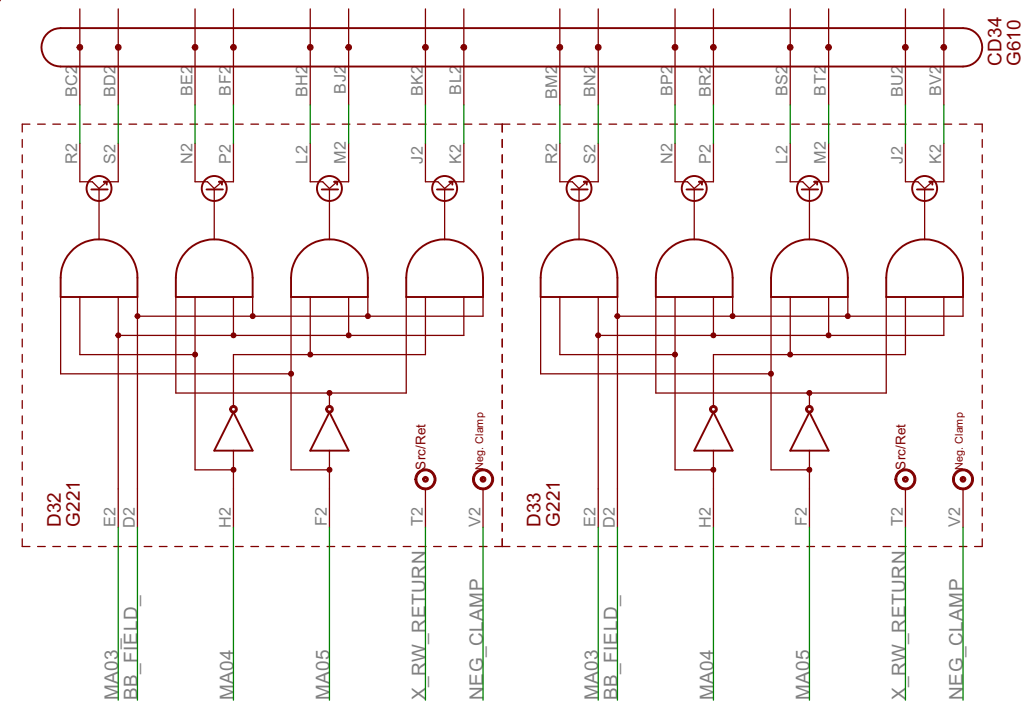

D-BS-8i-0-15 X Axis Selection	
TITLE: pdp8i-dec	
Document Number:	REV:
Date: 2/22/2021 2:11:40 AM	Sheet: 19/40

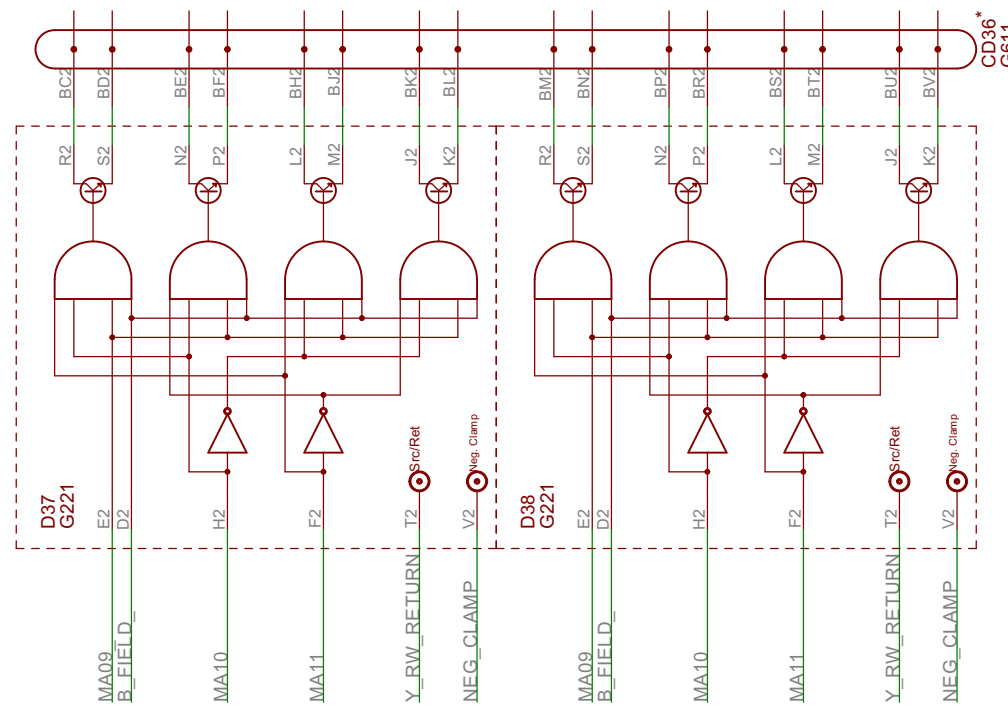
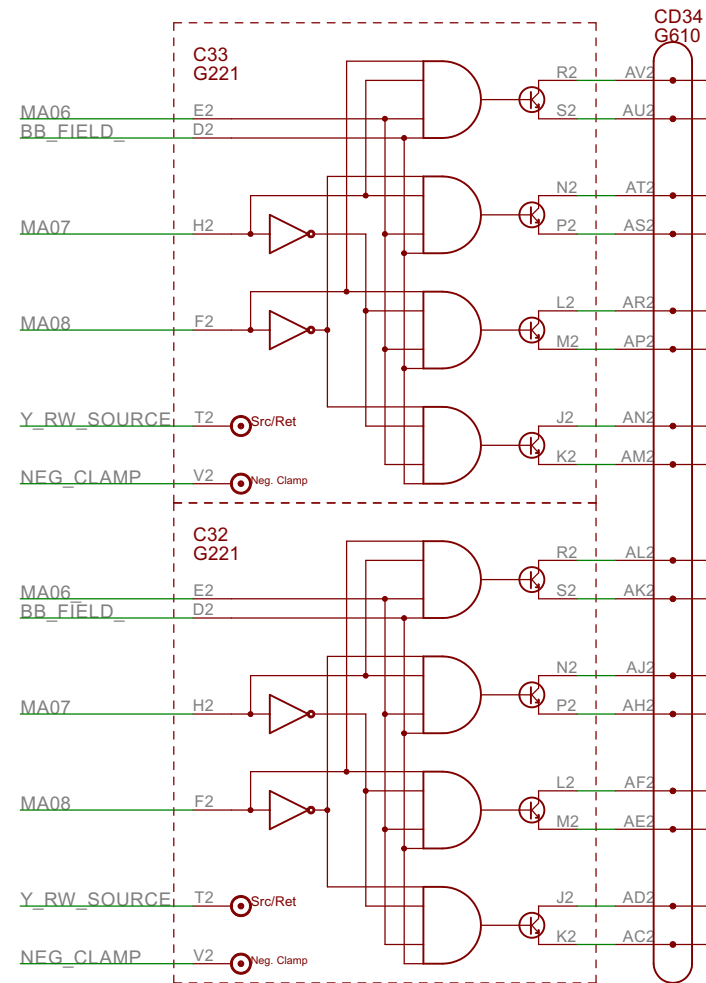

* G611 in CD36 is replaced with G612 for MP8i.

VCC
GND

D-BS-8i-0-16 Y Axis Selection

TITLE: pdp8i-dec

Document Number:

REV:

Date: 2/22/2021 2:11:40 AM

Sheet: 20/40

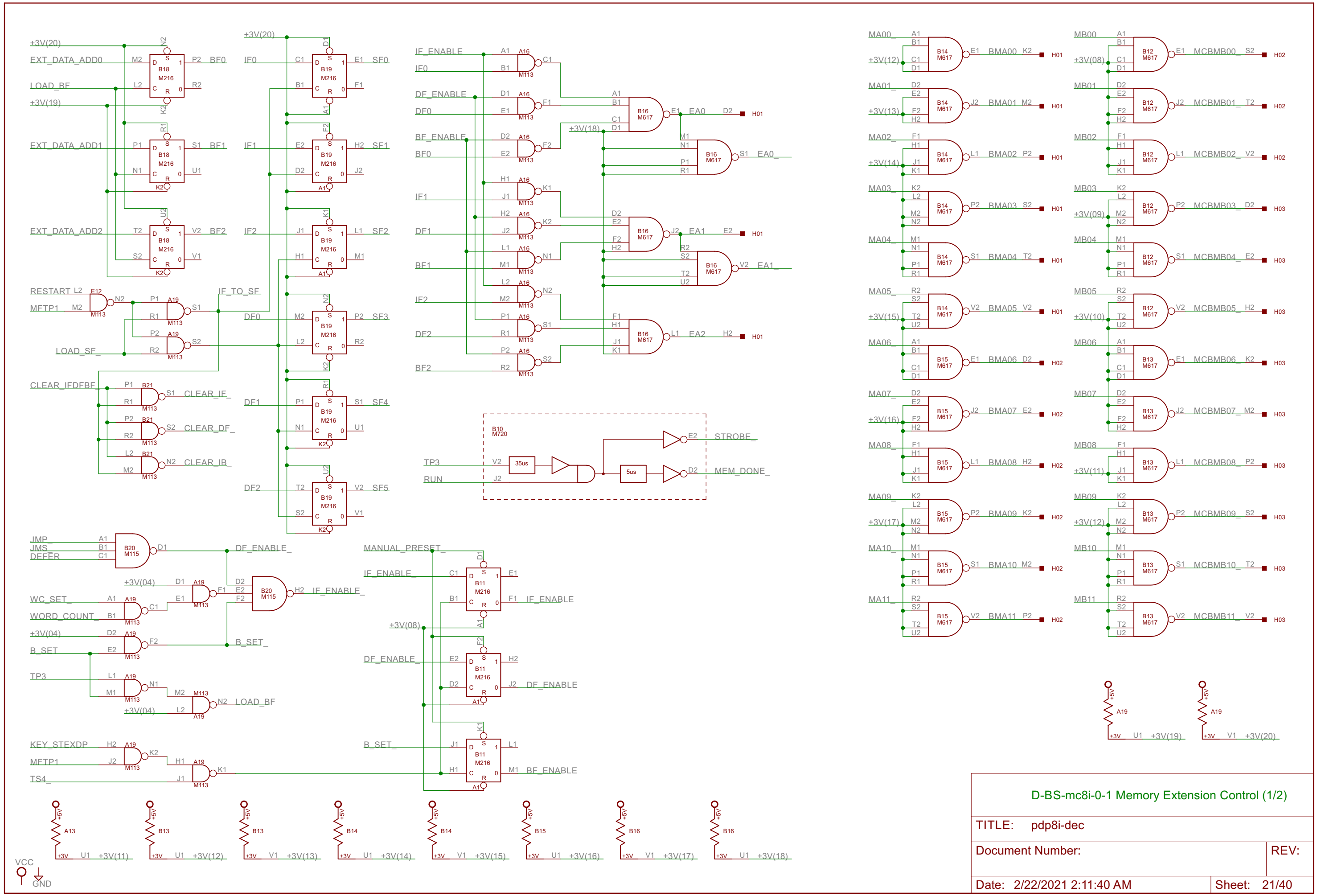

D-BS-mc8i-0-1 Memory Extension Control (1/2)

TITLE: pdp8i-dec	
Document Number:	REV:
Date: 2/22/2021 2:11:40 AM	Sheet: 21/40

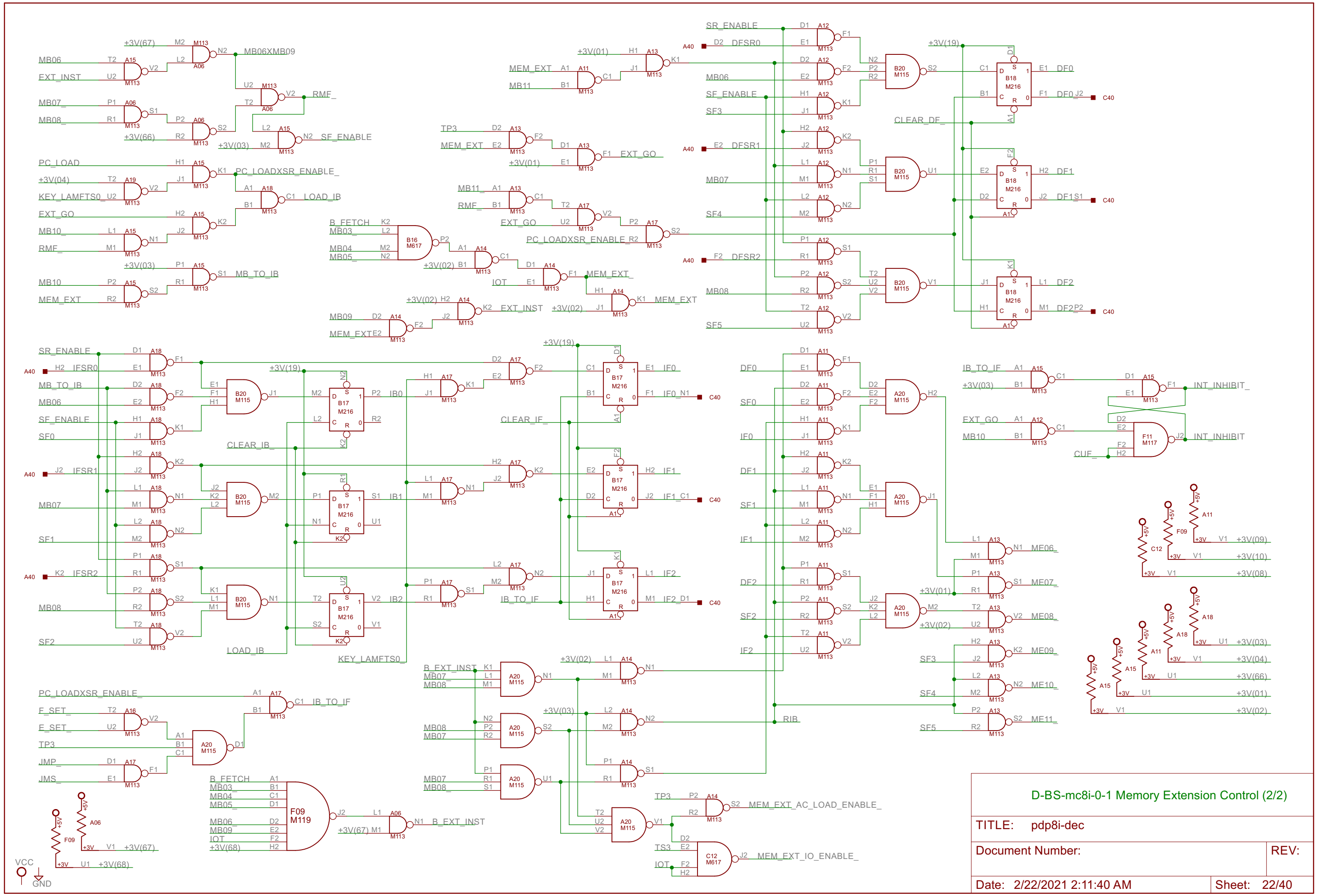

D-BS-mc8i-0-1 Memory Extension Control (2/2)

TITLE: pdp8i-dec	
Document Number:	REV:
Date: 2/22/2021 2:11:40 AM	Sheet: 22/40

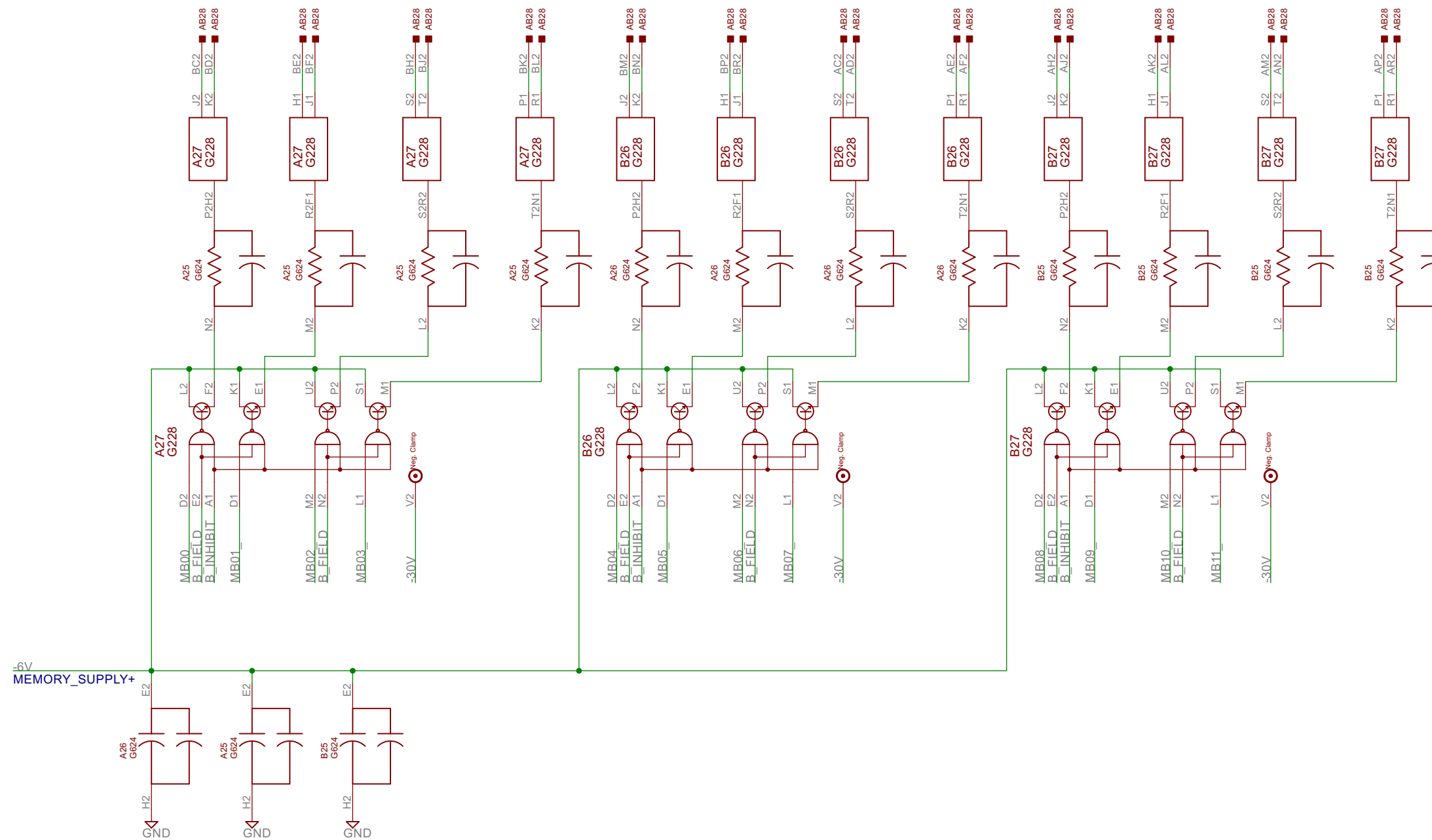

Memory Parity bit is handled in A37 on D-BS-8i-0-14.

D-BS-mc8i-0-2 Inhibit Drivers

TITLE: pdp8i-dec

Document Number:

REV:

Date: 2/22/2021 2:11:40 AM

Sheet: 23/40



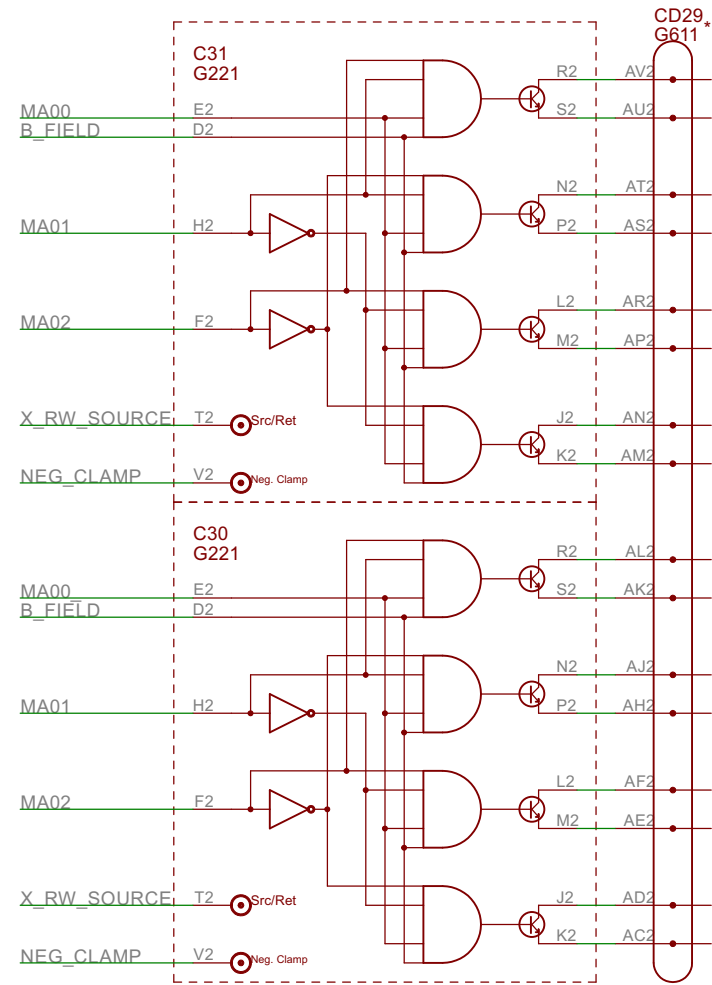

* G611 in CD29 is replaced with G612 for MP8i.

Core Memory:
C28
D28

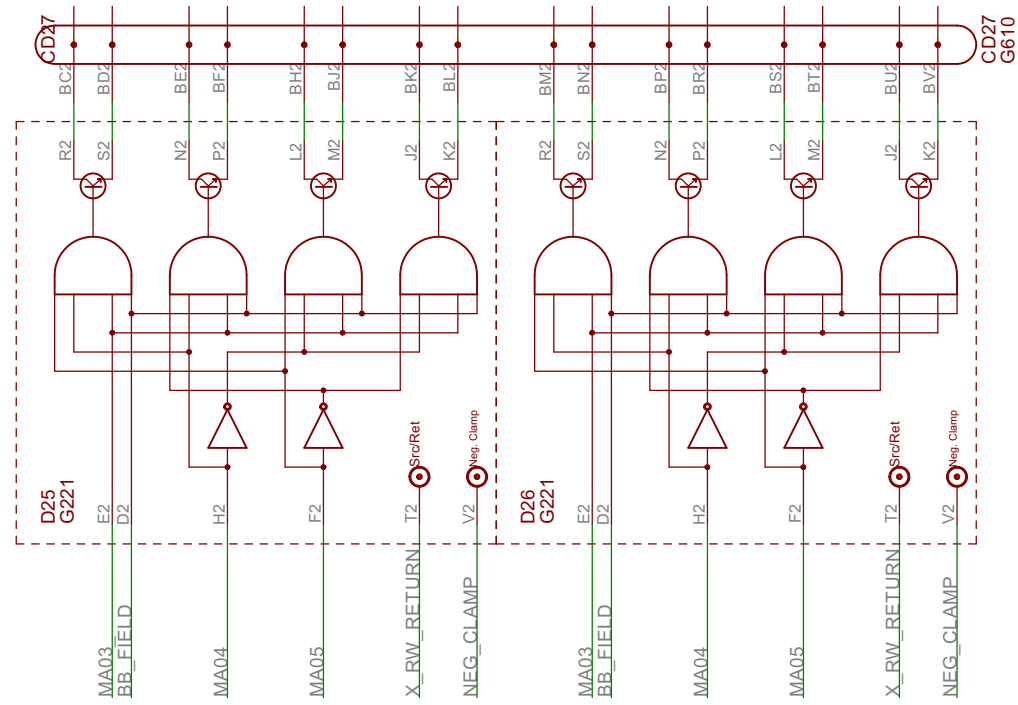

VCC
GND

D-BS-mc8i-0-3 X Axis Selection

TITLE: pdp8i-dec

Document Number:

REV:

Date: 2/22/2021 2:11:40 AM

Sheet: 24/40

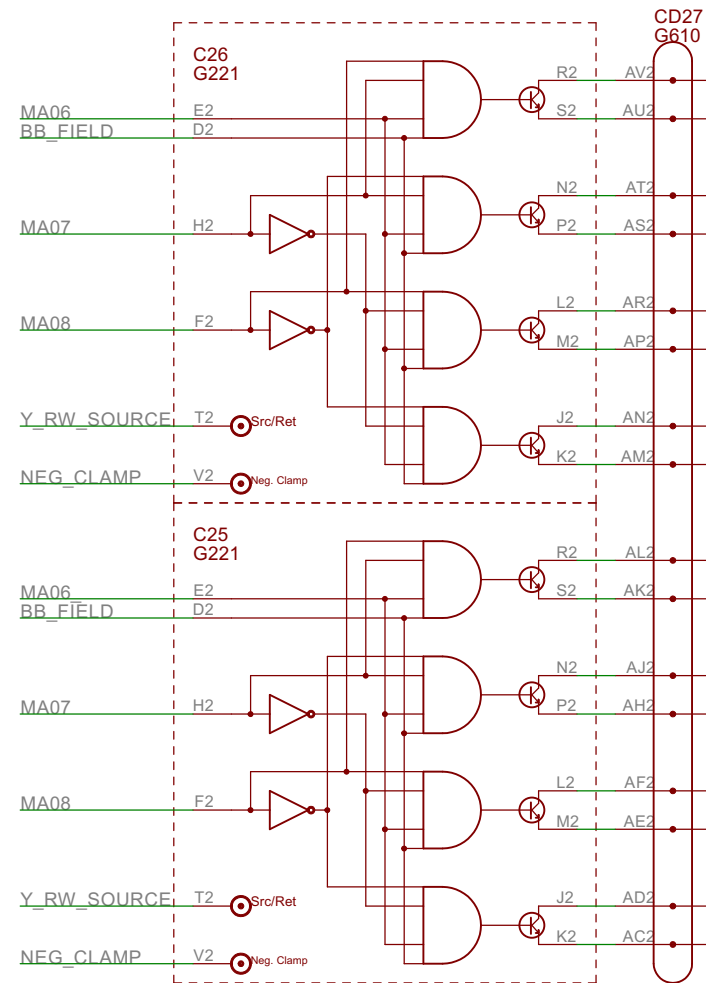

Core Memory:
C28
D28

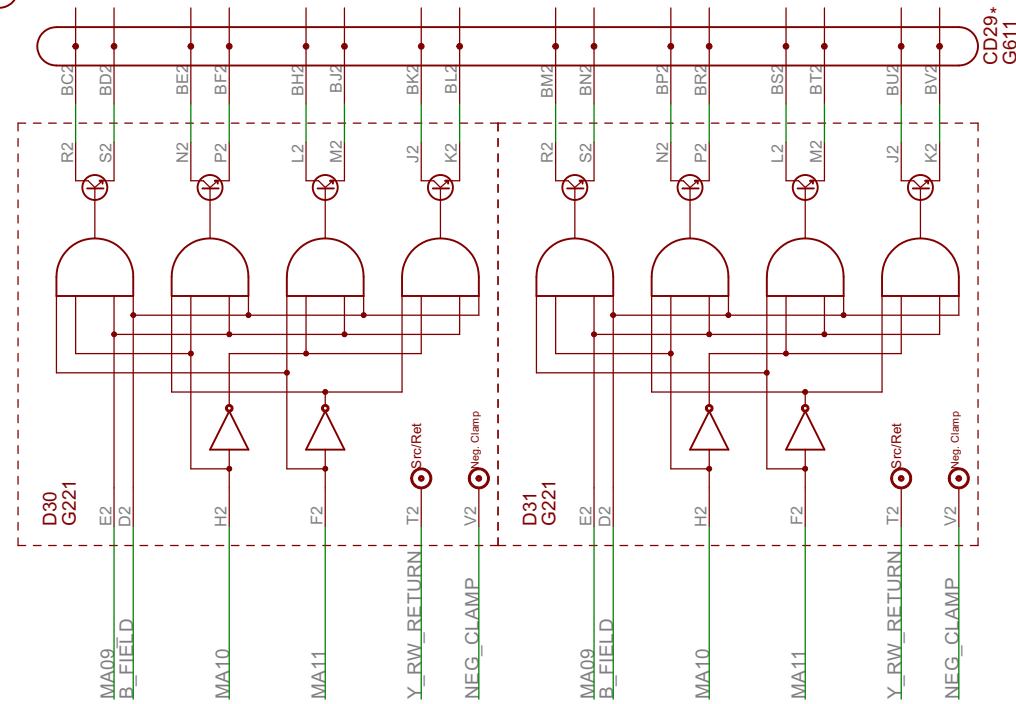

* G611 in CD29 is replaced with G612 for MP8i.

VCC
GND

D-BS-mc8i-0-4 Y Axis Selection

TITLE: pdp8i-dec

Document Number:

REV:

Date: 2/22/2021 2:11:40 AM

Sheet: 25/40

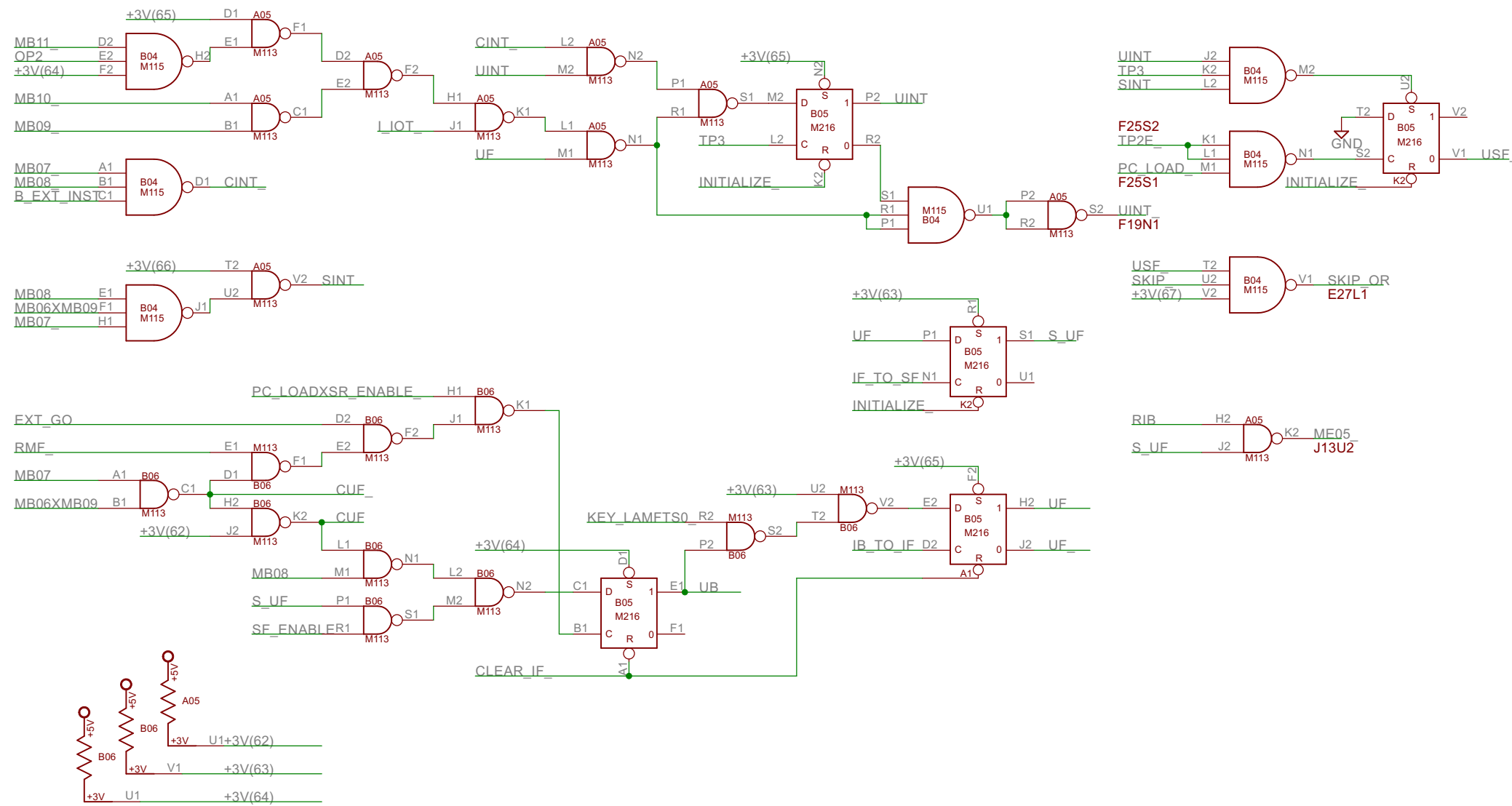

NOTE:

PIN	PRINT	LOCATION
J13U2	8i-0-10	C-6
F19N1	8i-0-12	A-6
E27L1	8i-0-5	D-3
F25S2	8i-0-6	B-4
F25S1	8i-0-6	D-2

(Locations refer to DEC drawings.)



D-BS-kt8i-0-1 Time-share Option

TITLE: pdp8i-dec

Document Number:

REV:

Date: 2/22/2021 2:11:40 AM

Sheet: 26/40

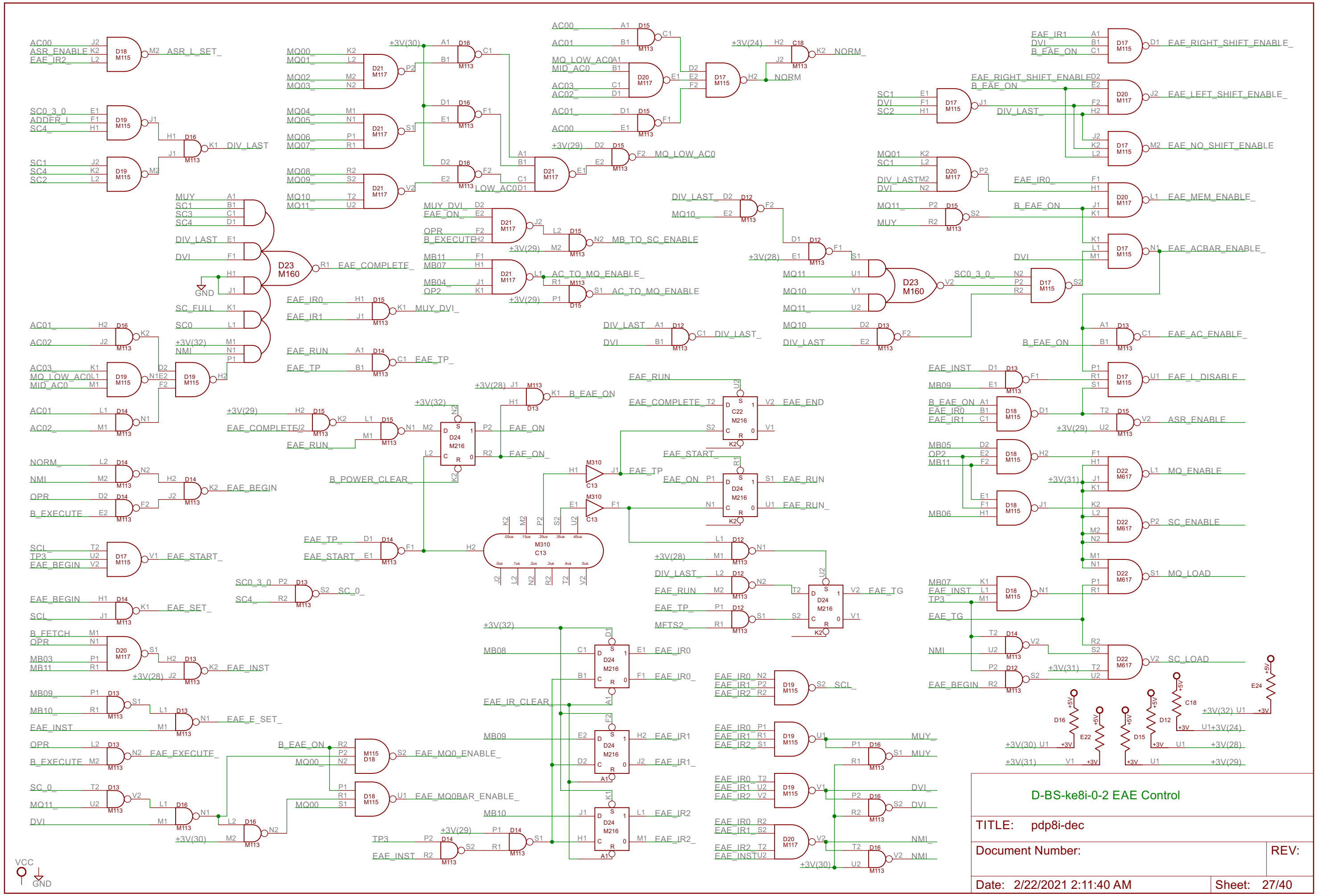

D-BS-ke8i-0-2 EAE Control	
TITLE: pdp8i-dec	
Document Number:	REV:
Date: 2/22/2021 2:11:40 AM	Sheet: 27/40



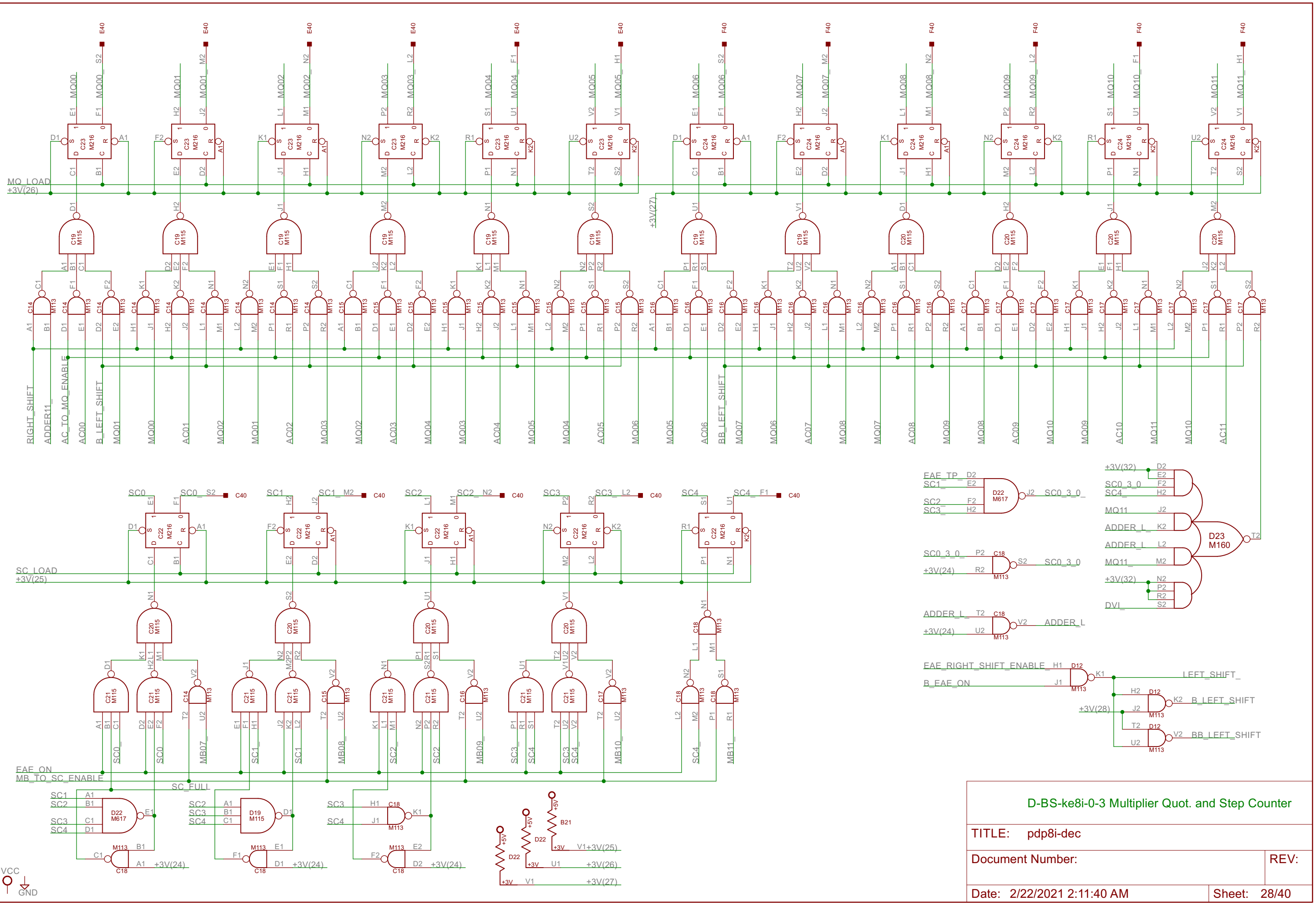

D-BS-ke8i-0-3 Multiplier Quot. and Step Counter	
TITLE: pdp8i-dec	
Document Number:	REV:
Date: 2/22/2021 2:11:40 AM	Sheet: 28/40

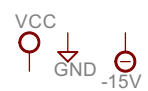
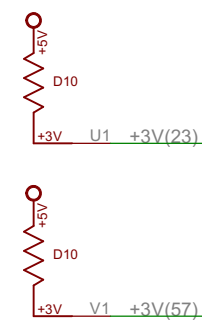
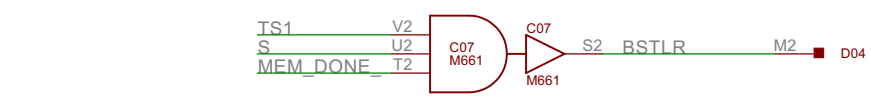
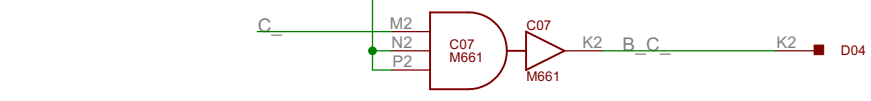
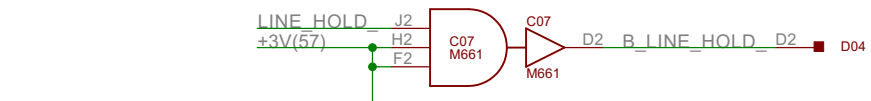
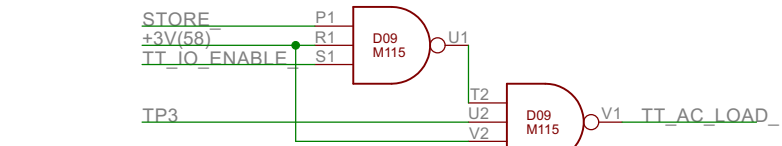
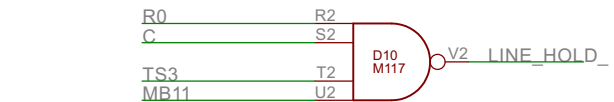
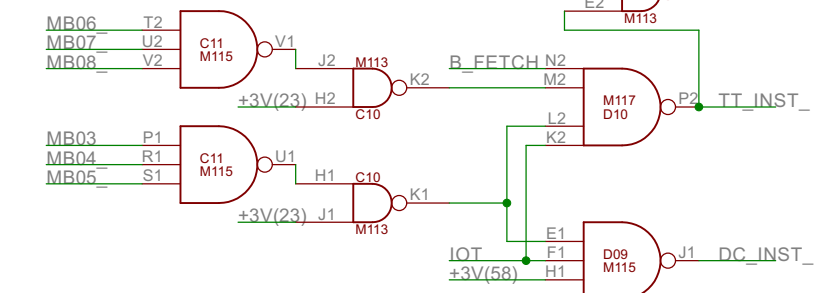
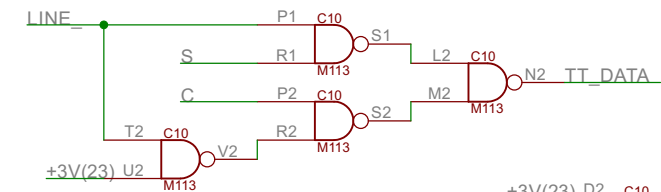
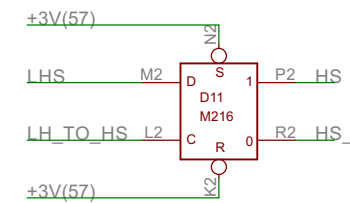
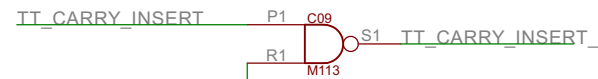
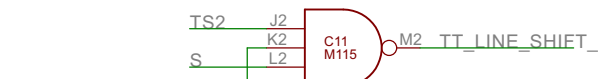
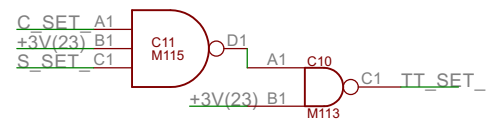
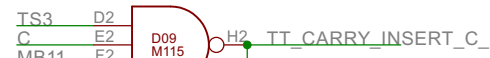
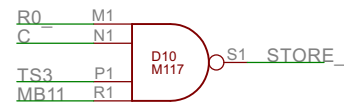
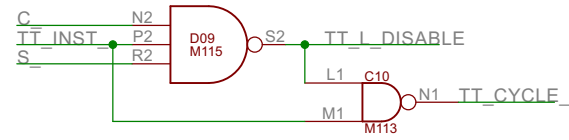
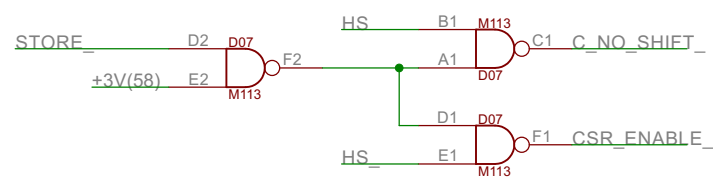
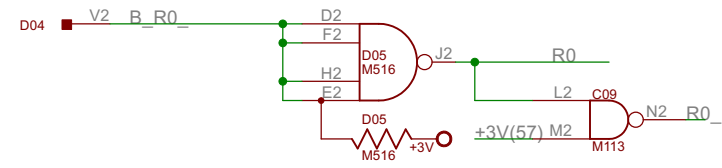
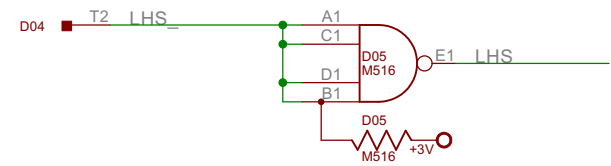
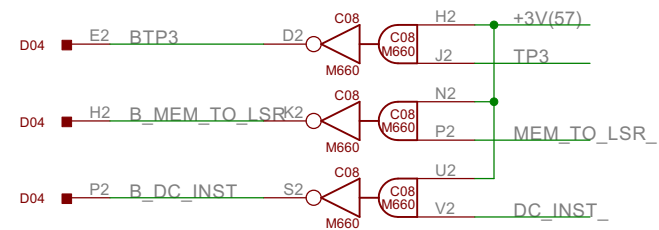
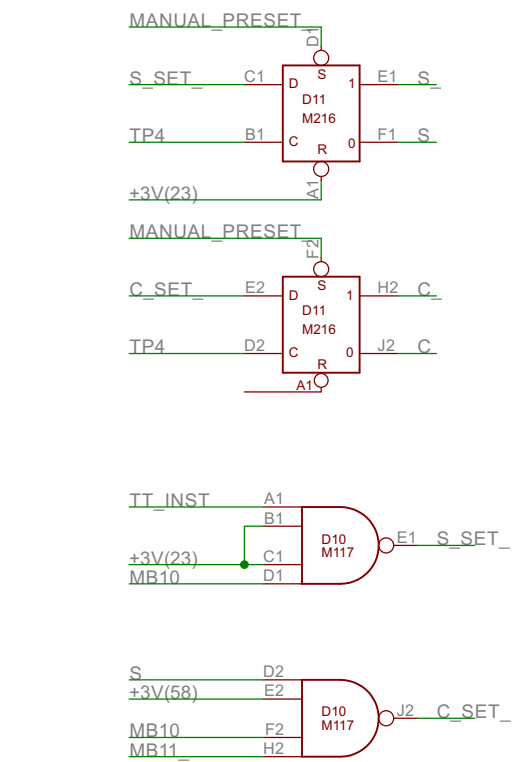

D-BS-dl8i-0-2 Data Line Interface

TITLE: pdp8i-dec	
Document Number:	REV:
Date: 2/22/2021 2:11:40 AM	Sheet: 29/40

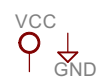
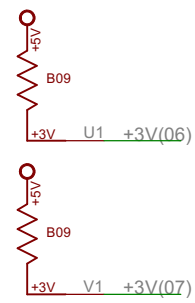
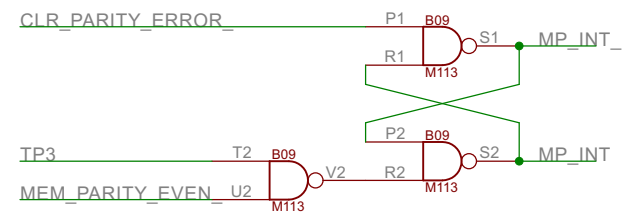
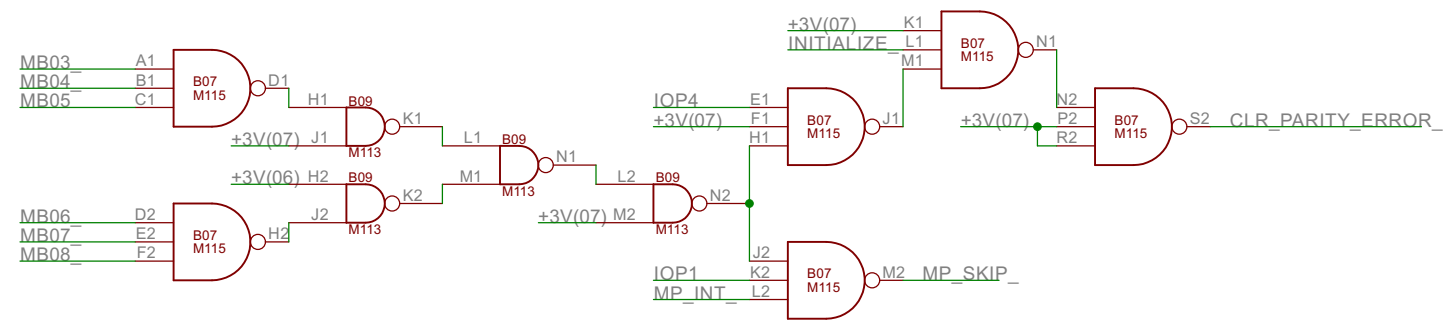
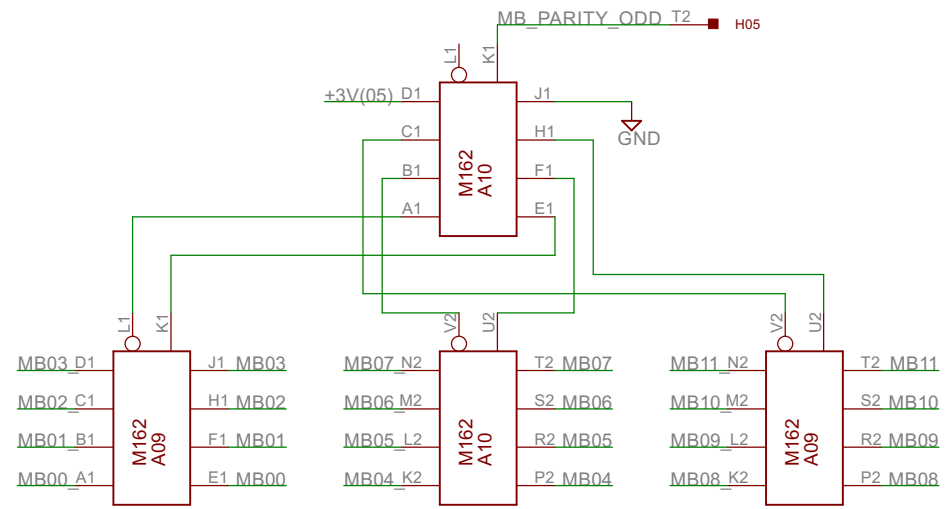

D-BS-mp8i-0-1 Memory Parity Option (1/2)

TITLE: pdp8i-dec

Document Number:

REV:

Date: 2/22/2021 2:11:40 AM

Sheet: 30/40

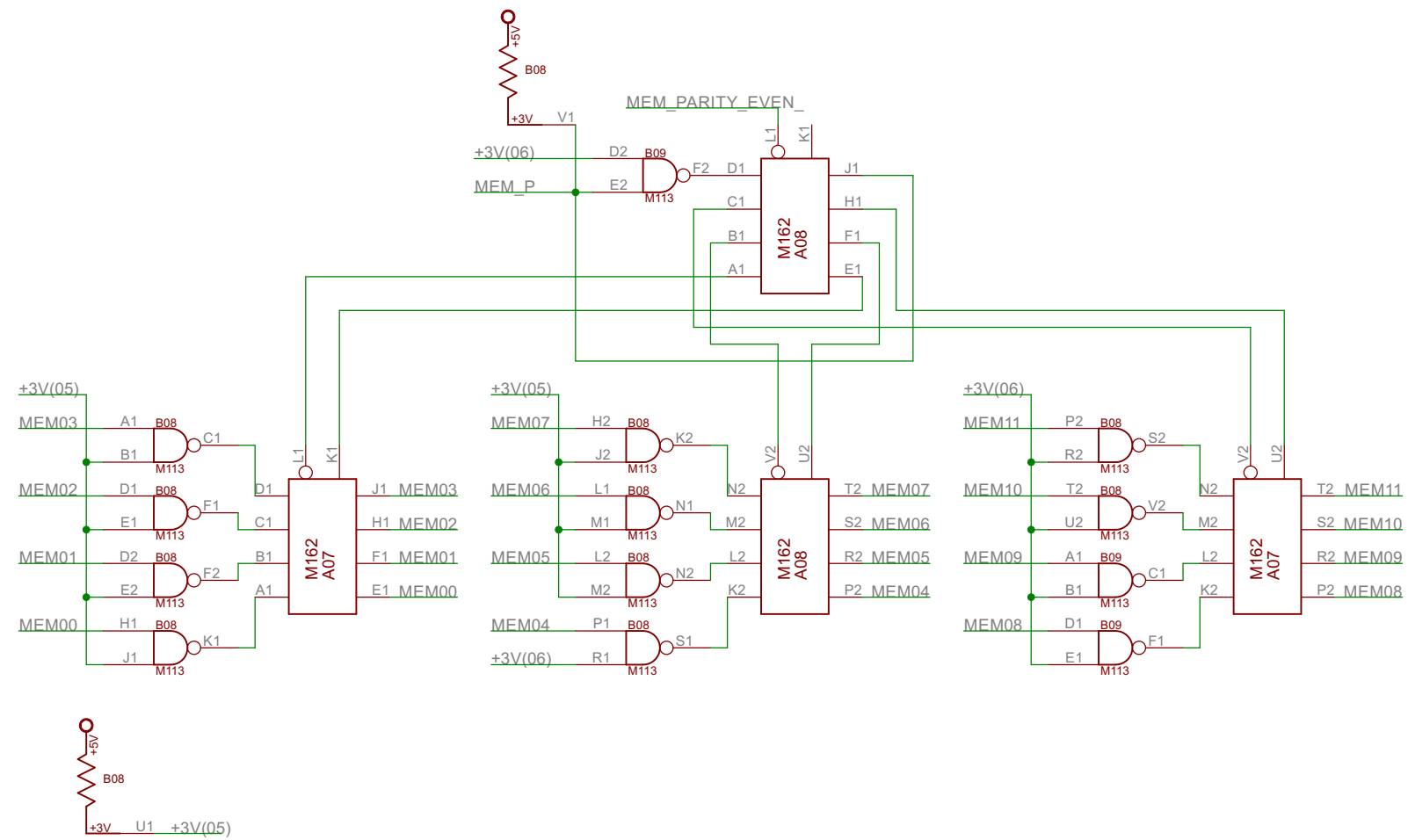

VCC
GND

D-BS-mp8i-0-1 Memory Parity Option (2/2)

TITLE: pdp8i-dec

Document Number:

REV:

Date: 2/22/2021 2:11:40 AM

Sheet: 31/40

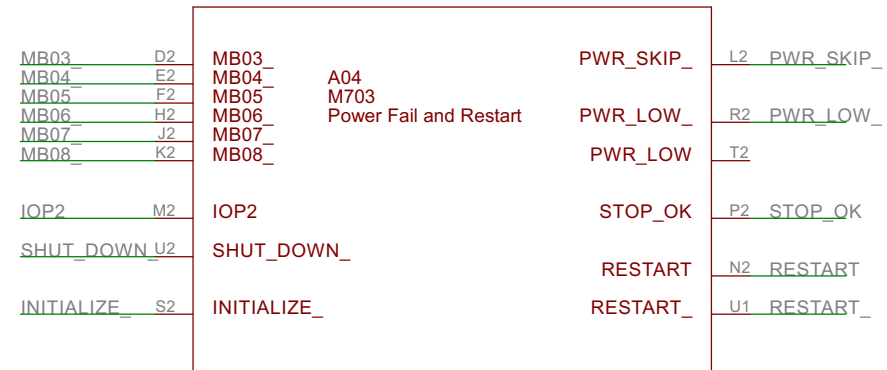

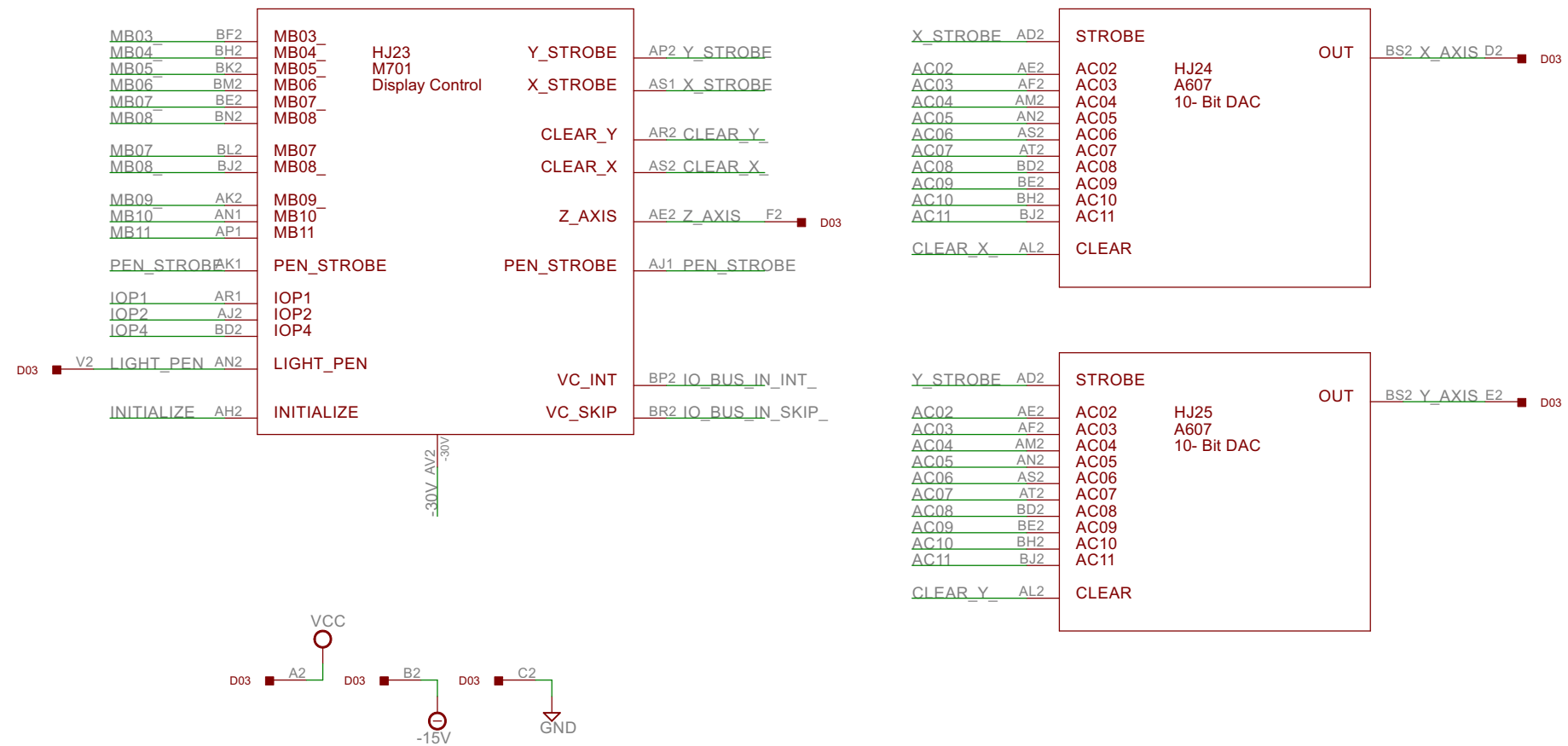

D-BS-vc8i-0-1 Display Control

TITLE: pdp8i-dec

Document Number:

REV:

Date: 2/22/2021 2:11:40 AM

Sheet: 33/40

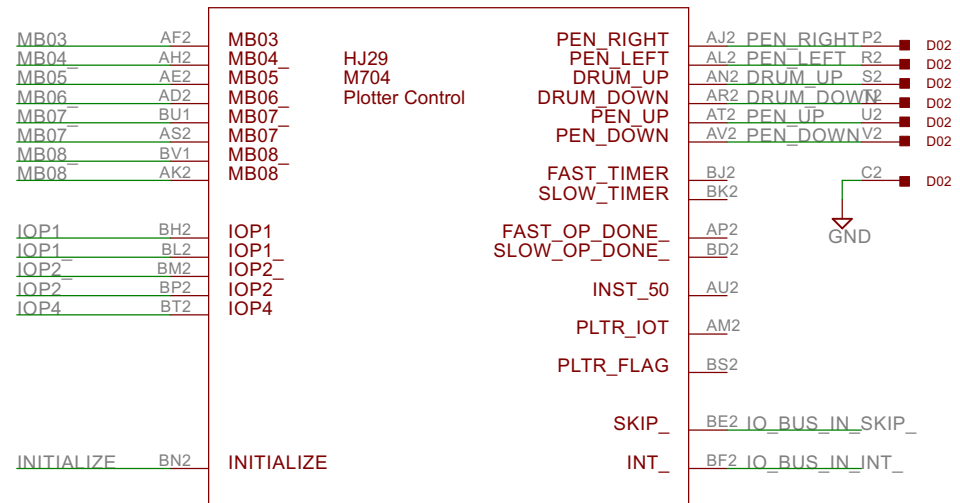

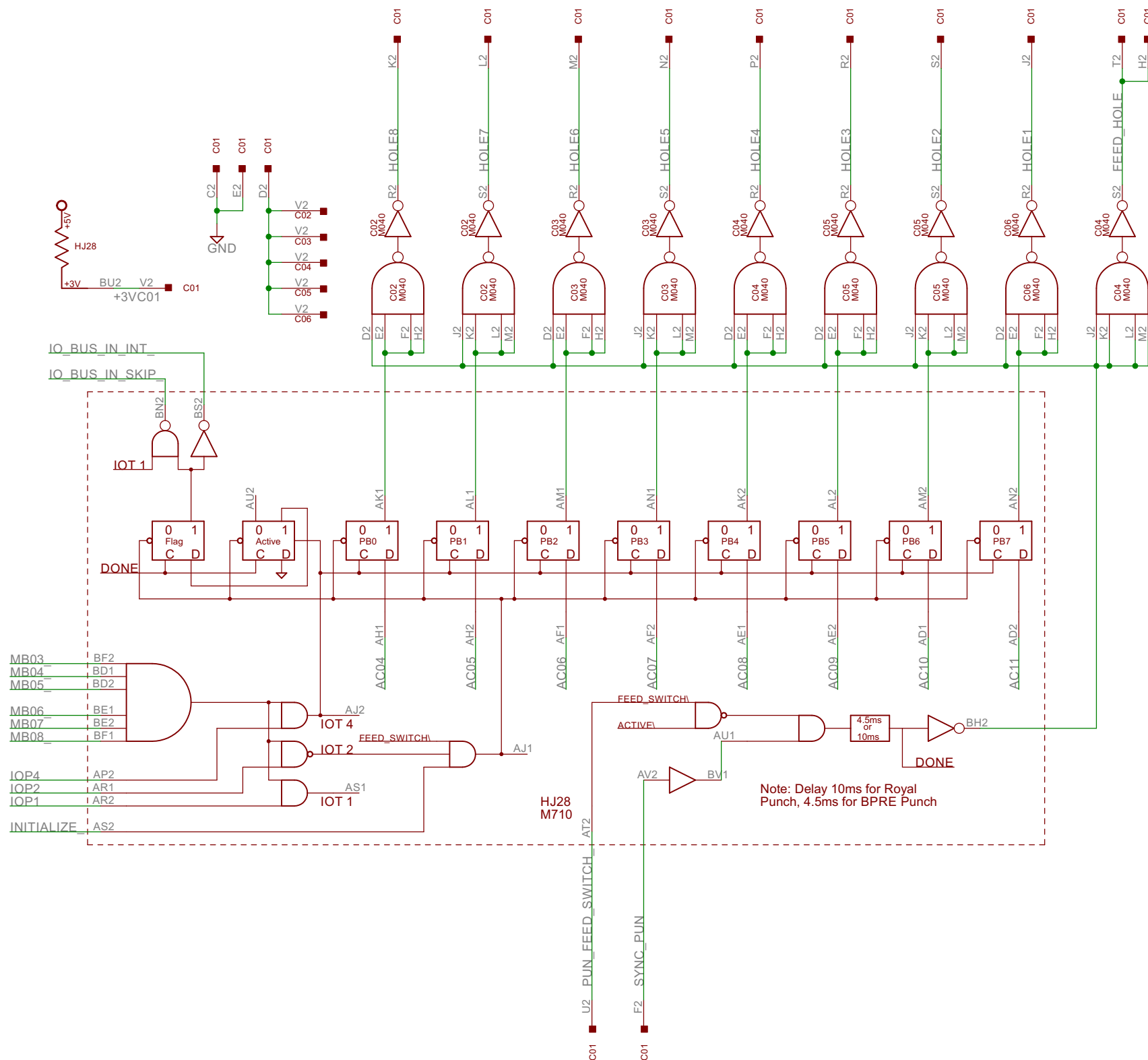

D-BS-pp8i-0-1 High Speed Punch

TITLE: pdp8i-dec

Document Number:

REV:

Date: 2/22/2021 2:11:40 AM

Sheet: 35/40



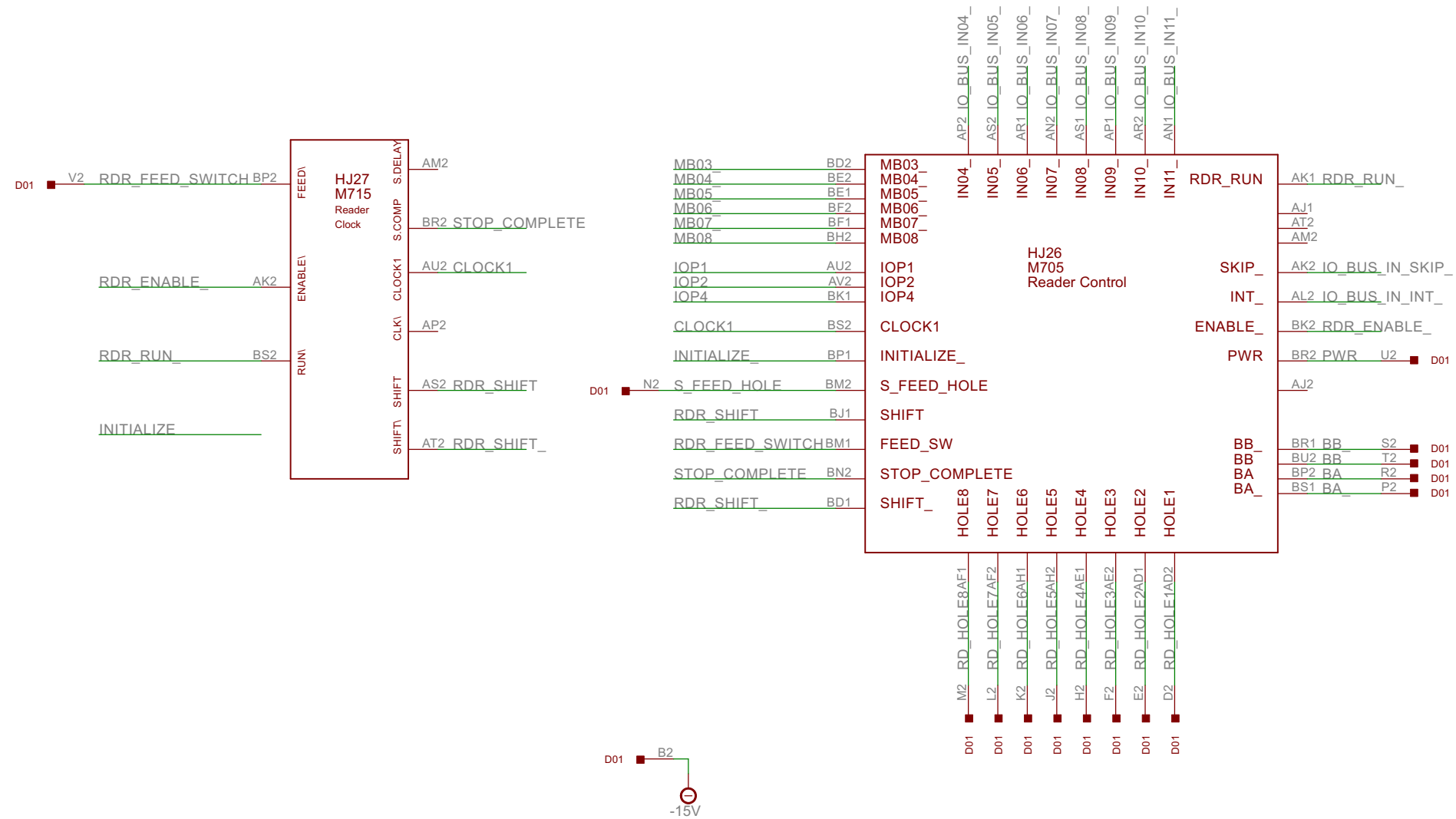

D-BS-pr8i-0-1 High Speed Reader	
TITLE: pdp8i-dec	
Document Number:	REV:
Date: 2/22/2021 2:11:40 AM	Sheet: 36/40

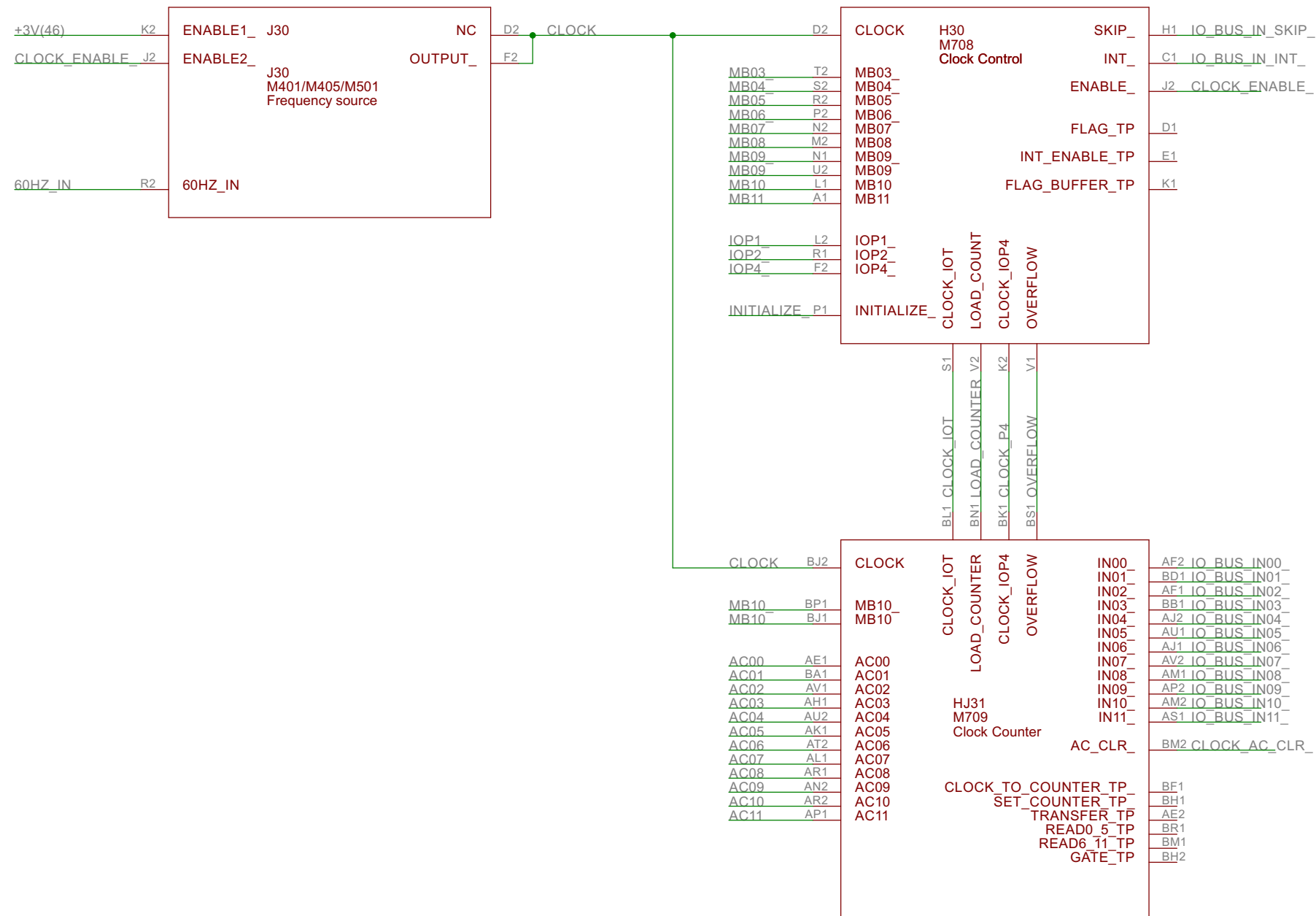

VCC
GND

D-BS-kw8i-0-1 Real Time Clock Option

TITLE: pdp8i-dec

Document Number:

REV:

Date: 2/22/2021 2:11:40 AM

Sheet: 37/40

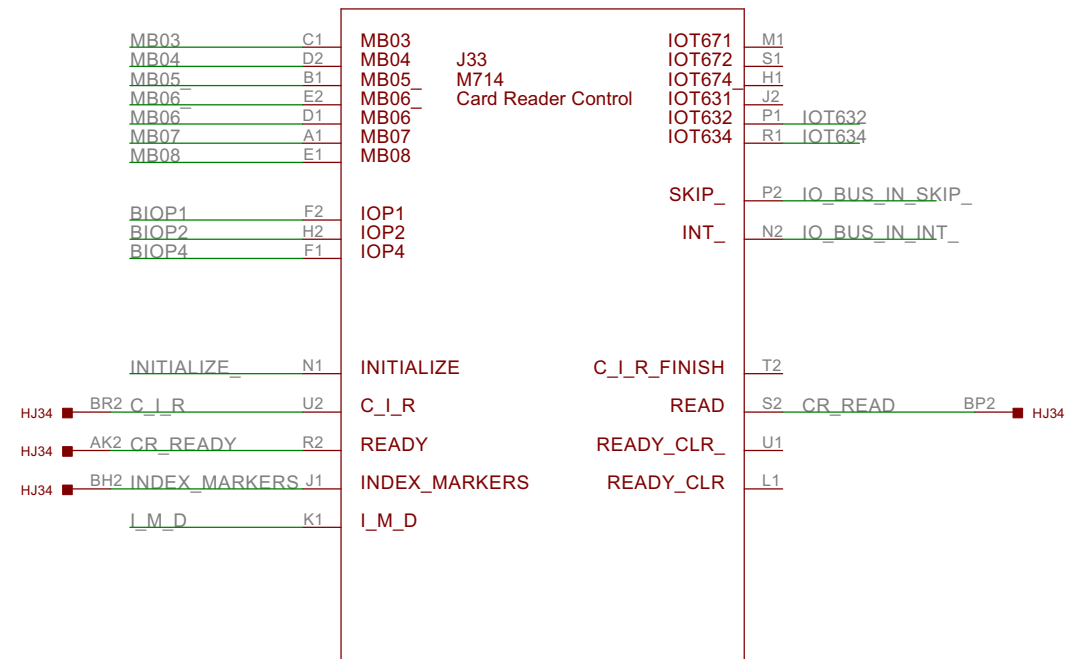

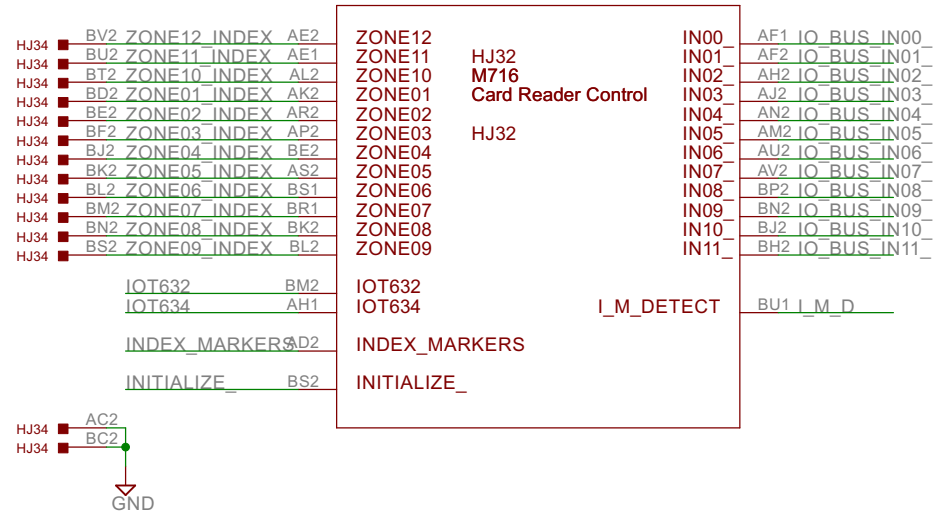

VCC
↓
GND

TITLE: pdp8i-dec

Document Number:

REV:

Date: 2/22/2021 2:11:40 AM

Sheet: 40/40