

DEC Datasystem Installation Manual

1st Edition, March 1978
1st Edition (Rev), June 1978
1st Edition (Rev), Feb 1979

Copyright © 1978, 1979 by Digital Equipment Corporation

The material in this manual is for informational purposes and is subject to change without notice.

Digital Equipment Corporation assumes no responsibility for any errors which may appear in this manual.

Printed in U.S.A.

The following are trademarks of Digital Equipment Corporation, Maynard, Massachusetts:

DIGITAL	DECsystem-10	MASSBUS
DEC	DECSYSTEM-20	OMNIBUS
PDP	DIBOL	OS/8
DECUS	EDUSYSTEM	RSTS
UNIBUS	VAX	RSX
	VMS	IAS

CONTENTS

	Page
PREFACE	
CHAPTER 1 INTRODUCTION	
1.1 HANDLING	1-1
1.2 INSPECTION.....	1-1
CHAPTER 2 INSTALLATION	
2.1 REQUIRED TOOLS.....	2-1
2.2 CABINET DISASSEMBLY	2-1
2.3 CABINET LEVELING	2-6
2.4 INTERCONNECT CABINETS.....	2-7
2.5 CABLING	2-9
2.5.1 Internal Signal Cables.....	2-9
2.5.2 AC Power Cables	2-9
2.5.3 External Signal Cables	2-10
2.5.4 Typical Cabling Configurations	2-11
2.6 CABINET REASSEMBLY.....	2-11
CHAPTER 3 ACCEPTANCE AND TEST PROCEDURES	
APPENDIX FIELD REPLACEABLE PARTS	

FIGURES

Figure No.	Title	Page
2-1	Rear Door Opening Tool	2-1
2-2	Quick Release Latches	2-2
2-3	Cabinet Frame, Front View.....	2-3
2-4	Leveler Foot and Stabilizer Arm	2-3
2-5	Removing Back Door	2-4
2-6	Top Cover Fastener	2-5
2-7	Typical Datasystem Cabling Scheme.....	2-8
2-8	Cable Exit from Cabinet	2-9
2-9	Exit of AC Line Cord.....	2-10
2-10	Datasystem 530 Cabling Diagram Free-Standing Disk, Basic Configuration	2-11
2-11	Datasystem 530 Cabling Diagram Free-Standing RK06 Disk with TE10W Configuration.....	2-12
2-12	Datasystem 530 Cabling Diagram Free-Standing RK06 Disk with TE16 Configuration	2-12

FIGURES (Cont)

Figure No.	Title	Page
2-13	Datasystem 534 TE16 Configuration	2-13
2-14	Datasystem 570 Cabling Diagram	2-13
A-1	H9500 Cabinet-Top View	A-1
A-2	Single-width Hiboy Cabinet with 28 Inch Front Cover	A-2
A-3	Single-width Hiboy Cabinet with 12 Inch Front Cover	A-3
A-4	Double-width Hiboy Cabinet	A-4
A-5	Wheel Lock Assembly	A-5
A-6	Vertical Panel for Single-width Hiboy Cabinet (H9602)	A-6
A-7	Initializer Panel (1 of 3)	A-7
A-8	Initializer Panel (2 of 3)	A-8
A-9	Initializer Panel (3 of 3)	A-9
A-10	Trim Strip and Intercabinet Filler Strips	A-10
A-11	BA11-F Front Covers	A-11
A-12	Three Panel Front Cover	A-12
A-13	5 1/4 Bezel for 11/34	A-13
A-14	PDP-11/34 Sheet Metal Bezel	A-14
A-15	Battery Back-up for PDP-11/34 System	A-15
A-16	Fan Assembly for TS03 Magnetic Tape Unit	A-16
A-17	H957 Fan Assembly	A-17
A-18	Connector Mounting Plate (Z Bracket)	A-18
A-19	Vertical Connector Mounting Plate	A-19
A-20	Massbus Connector and Mounting Plate	A-20
A-21	H317 Distribution Panel Mounting Hardware	A-21
A-22	Roll Bar	A-22
A-23	Counterweight Bracket for H9602 Cabinet	A-23
A-24	Shipping Bracket for RK05 Disk Drive	A-24
A-25	Transition Bracket	A-25
A-26	Safety Strap for Single RL01	A-26
A-27	Safety Strap for Dual RL01's	A-27

PREFACE

This manual provides the information needed to install the H9500 series cabinet, either standalone or multi-cabinet systems. The appendix contains detailed drawings and part numbers for many of the cabinet sub-assemblies. For a list of the drawings, refer to page iv. The appendix had been published previously as the *DEC Datasystem Supplementary Installation Guide* (ED-DDSS-IN-001); it will no longer be published separately.

CHAPTER 1 INTRODUCTION

1.1 HANDLING

The cabinet has shock-isolating casters, and therefore will arrive without a shipping skid. Because the cabinet is top heavy, a forklift should *not* be used when moving it. However, if it is absolutely necessary to use a forklift, insert it from the front or back of a double-width cabinet, or from the side of a single-width cabinet. Only one tine of a forklift will fit under a single-width cabinet; therefore, take care to support and balance the cabinet before moving it.

Do not remove the wheel locks unless absolutely necessary (refer to figure A-5).

CAUTION

The cabinet's high center of gravity must be kept in mind whenever moving it. It may become unstable when tilted more than 10 degrees.

1.2 INSPECTION

Visually inspect the cabinet carefully for possible shipping damage. Check the packing list enclosed with the cabinet for lost or missing items. Report any damaged items to the Field Service branch supervisor and to the local carrier. Report missing items to Field Service Logistics.

CHAPTER 2 INSTALLATION

2.1 REQUIRED TOOLS

Tools required for installation are listed below.

1. 1.43 cm (9/16 in.) wrench or adjustable wrench
2. Phillips screwdriver
3. Thin-bladed tool, such as a metal ruler
4. Spirit level (optional)
5. Spanner wrench, i.e., rear door opening tool supplied with CPU cabinet (Figure 2-1) (DEC 12-13091)
6. Hex Key wrench (5/32 in.), rear door opening tool

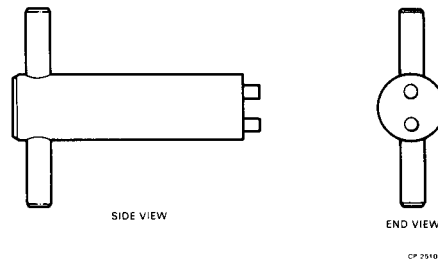

Figure 2-1 Rear Door Opening Tool
(DEC 12-13091)

2.2 CABINET DISASSEMBLY

The following steps explain removing the cabinet's outer panels and how to install the interlock system. Steps one and two are necessary for all cabinets. Steps three through five, describing removal of the remainder of the cabinet's outer panels, are necessary when two (or more) cabinets are bolted together.

NOTE

Ground straps (10 gauge stranded wire) connect the front panel, end panels, and rear door to the frame of the cabinet. To remove a panel, separate the panel from the frame (see following procedure), disconnect the ground strap, then completely remove the panel.

1. Remove Front Panel.

There are two variations of the front panel. One is 85 cm (28 in) high and has an array of vertical slots across its front. Approximately 2.54 cm (1 in) behind the last slot at each end of the array is a quick release latch. Release the panel by inserting a thin-bladed tool, such as a thin ruler into one of the end slots, while pulling the corner of the panel away from the cabinet. Release the other top corner in the same manner and lift the front panel up and off the two tabs on the front of the cabinet.

The second variation is 30 cm (12 in) high and, instead of an array of slots, has two 1/4 inch diameter holes. In the same manner as above, insert a tool into each hole and lift the front panel off the two tabs on the front of the cabinet.

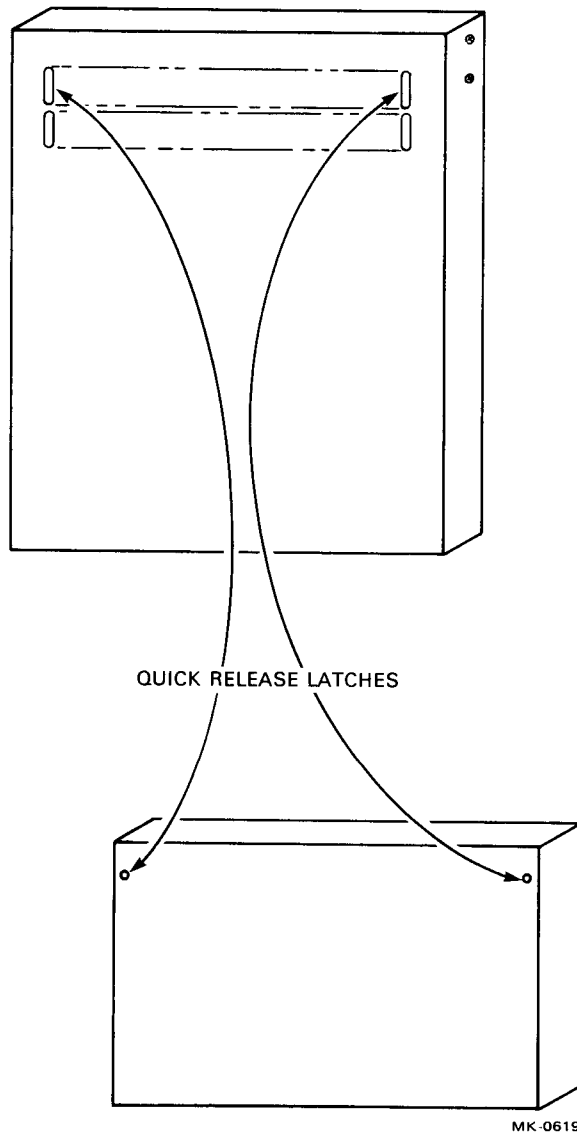

Figure 2-2 Quick Release Latches

2. Stabilizer Arm and Mechanical Interlocks.

Each cabinet has two mechanical interlock rods, one located in the middle of each front vertical upright, positioned over a stabilizer arm channel (Figure 2-3). To remove the stabilizer arm, untape it and, reaching into the cabinet, lift the interlock rod while sliding the arm completely out of its channel. Screw a leveler foot (shipped loose piece) into the end of each arm (Figure 2-4). Refer to figure A-2 for part numbers.

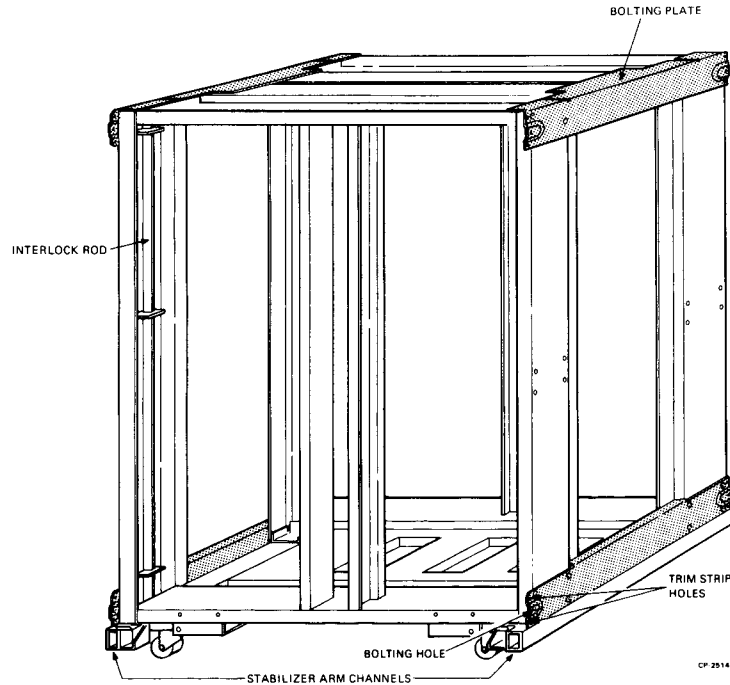

Figure 2-3 Cabinet Frame, Front View

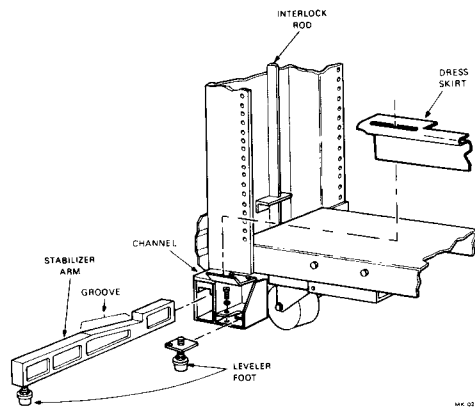

Figure 2-4 Leveler Foot and Stabilizer Arm

Install the stabilizer arm by lifting the interlock rod while sliding the arm into its channel until the rod is able to rest in the groove at the top of the arm. Now lower the leveler foot on each arm until it touches the floor, but still slides easily along the floor.

NOTE

Before extending a sliding device from the cabinet, pull the stabilizer arm forward until the interlock rod falls into the groove, thereby holding the stabilizer arm in the extended position.

3. Remove Rear Door.

To unlock the rear door, insert the door opening tool, either a hex key wrench or spanner wrench (Figure 2-1) and turn it 1/4 turn in a counterclockwise direction (tool is a loose piece shipped with the cabinet). Remove the door by swinging it open 90 degrees and lifting it off at the hinges (Figure 2-5).

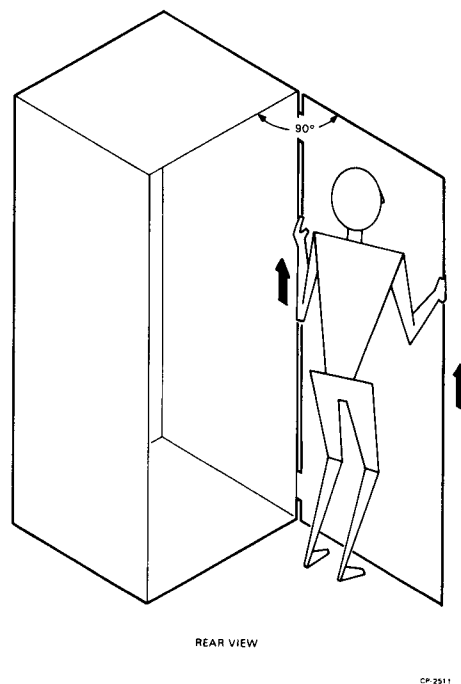

Figure 2-5 Removing Back Door

4. Remove Top Cover.

Reach into the cabinet and find the fastener on the underside of the top cover. It is located as shown in Figure 2-6. If hard-mounted equipment is blocking access to the fastener, the fastener was not installed. If slide-mounted equipment is blocking access, pull the stabilizer arms out into the lock position, remove shipping brackets, and slide out the equipment.

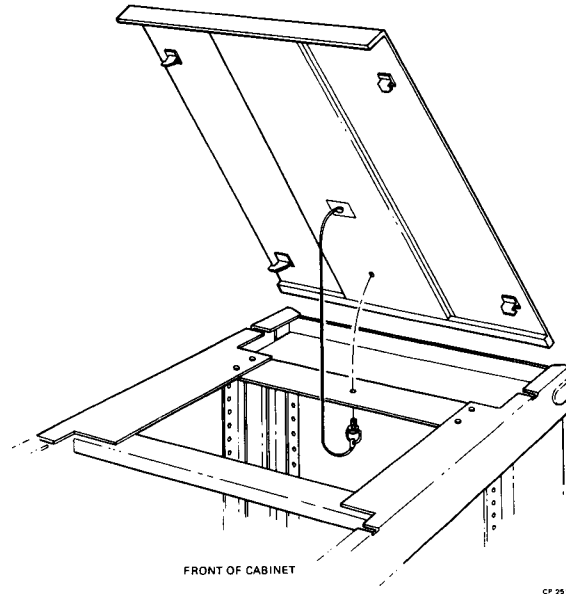

Figure 2-6 Top Cover Fastener

Release the top cover by turning the fastener 1/4 in a counterclockwise direction. When released, the fastener will hang from the cover support by a wire. Push the top cover forward about 1.27 cm (1/2 in). Walk to the front of the cabinet and lift off the cover.

5. Remove End Panels.

Remove each end panel by grasping it on both sides and lifting.

2.3 CABINET LEVELING

Due to weight differentials and a self-contained shock mount, the cabinets must be leveled at the time of installation. Proceed as follows to level them. (In a multi-cabinet system, push the cabinets into adjacent positions before leveling.)

1. Install the leveler feet (shipped loose piece) into the cabinet frame (Figure 2-4).
2. Using a 1.43 cm (9/16 in) wrench, lower the leveler feet until all four on each cabinet contact the floor.
3. Adjust the cabinet until most of its weight is shifted from the casters to the leveler feet. Due to the shock-isolating system, the casters will always touch the floor even when all of the cabinet's weight is transferred to the leveler feet. In a multi-cabinet system, adjust the highest cabinet first.
4. Using a spirit level, adjust the leveler feet until the cabinet is level (optional).
5. Adjust the adjacent cabinets to the level of the highest cabinet.

2.4 INTERCONNECT CABINETS

Each cabinet has four bolting plates: one on each upper and lower side edge (refer to Figure 2-3 and Figure A-10). To bolt the cabinets together, proceed as follows.

1. The bolting hole (the middle hole) at the end of each plate should align with the bolting hole on the plate of the adjacent cabinet.
2. Insert a 1/4-20x1/4 in. Lg. bolt into the lined-up bolting plate holes, add a kep nut, and tighten. (Bolts and nuts are provided.) This will provide a good horizontal alignment across the cabinet system.
3. Front, top, and rear filler strips are shipped loose piece with multi-cabinet systems. Attach them as shown in Figure A-10.
4. After all the cabinets have been bolted together, extend the stabilizer arms and adjust the leveler feet until each touches, but still slide easily along the floor.

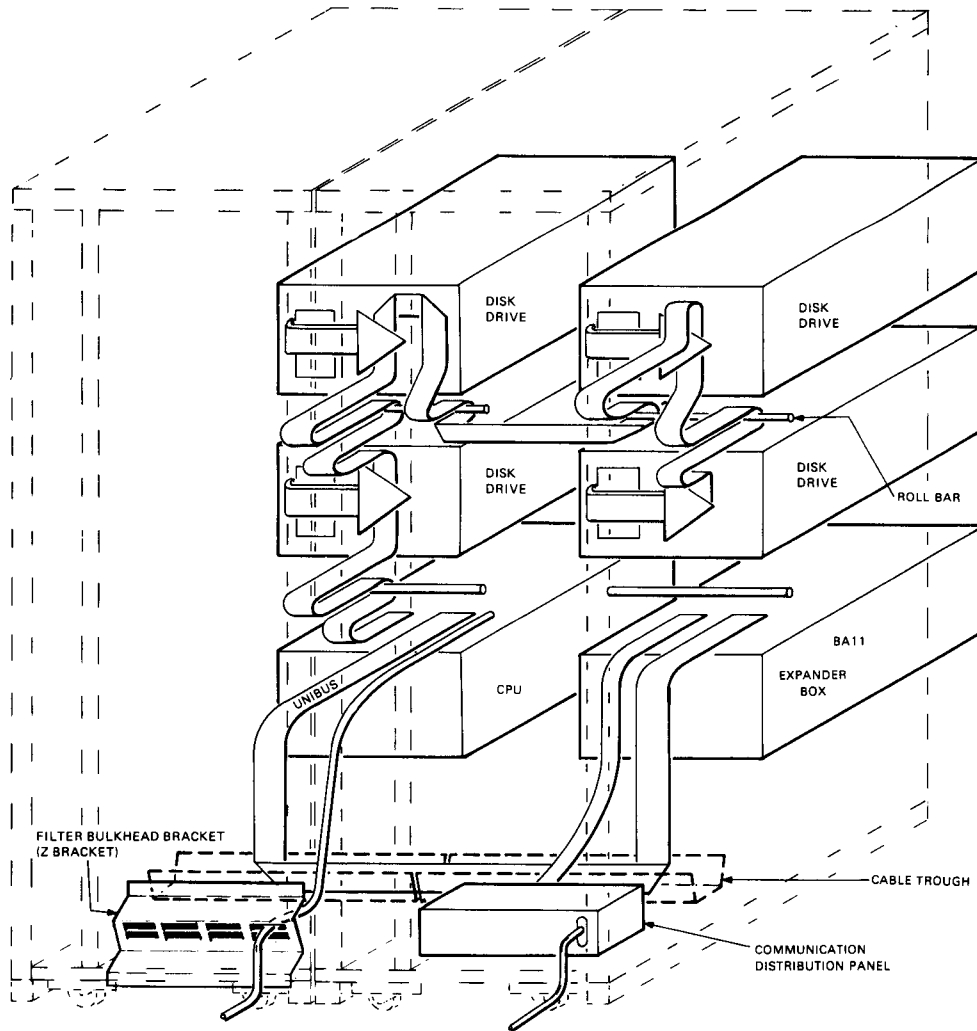

MK 0266

Figure 2-7 Typical Datasystem Cabling Scheme

(Rear view of cabinets with components pushed out halfway; roll bar is at front of cabinet.)

2.5 CABLING

Many features of the H9500 series cabinet were designed for the efficient use of cabling techniques aimed at reducing the possibility of cable damage and improving serviceability and appearance (Figure 2-7). At the center bottom of each cabinet is a cable trough that holds cables running horizontally within and between cabinets. Another aid in the arrangement of cables is the rod and tube assembly known as a "roll bar." Cables running vertically between devices within the same cabinet should be draped around the roll bar. This ensures that the cable will be long enough when the device is extended for servicing. Signal cables exiting a cabinet containing a central processing unit (CPU) pass through a filter bulkhead bracket. If the system includes a communications multiplexer, cables to the terminals exit the cabinet through the communications distribution panel. (The connection of cables between components requires no special tools.)

NOTE

All cables should exit the cabinet in the space between the frame and the back door. NOT through the bottom of the cabinet (Figure 2-8).

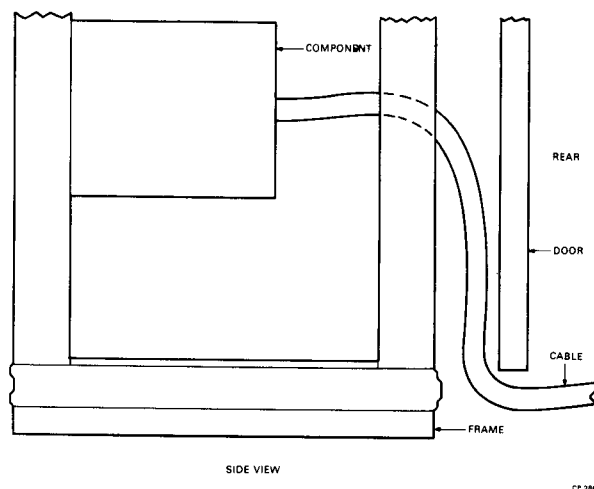

Figure 2-8 Cable Exit From Cabinet

2.5.1 Internal Signal Cables

Internal signal cables such as the RK05 disk drive bus, wrap around a roll bar as they run vertically between components. Figure 2-7 shows the position of the roll bars in a pair of single cabinets. This drawing also shows a cable trough containing internal signal cables that run horizontally across the bottom of the cabinet.

2.5.2 AC Power Cables

Three types of cables relating to ac power are used in these systems: external ac line cords, internal ac power cords, and power control signal cables. Each cabinet has an ac line cord that connects the power control to an outside ac power source. This cable exits the single and double cabinet from a specific location (Figure 2-9) and drops between the cabinet frame and the back door.

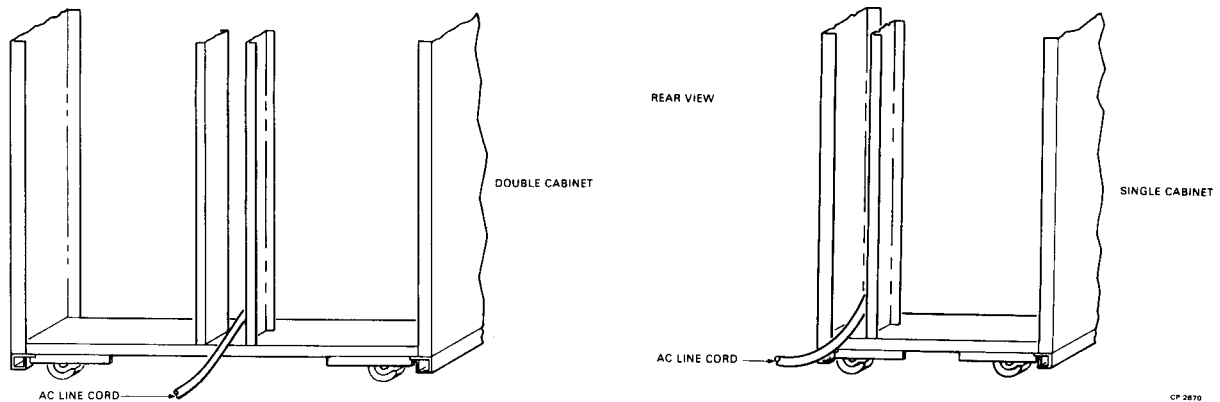

Figure 2-9 Exit of AC Line Cord

Each device in the cabinet that requires ac power plugs into an outlet on the power control box at the lower front of the cabinet. The power control signal cable starts at the power on/off switch on the initializer panel of the CPU cabinet and connects each power control box in the system in series. Therefore, when the system is powered up, all the components plugged into the power control boxes start at the same time. These round, thin, gray cables are tie-wrapped to the front uprights whenever possible in order to keep them out of the way of slide-mounted equipment.

2.5.3 External Signal Cables

External signal cables connect the central processing unit to its peripheral devices (i.e., printers, teleprinters, video terminals). These cables exit the CPU cabinet by means of a filter bulkhead bracket and then drop between the cabinet and back door. If a signal cable includes a static suppression filter, the filter is attached to the filter bulkhead bracket.

Static Suppression Filters - Static suppression filters are attached to some external signal cables to divert and dissipate energy wavefronts originating in peripheral devices before they can disrupt the CPU or main memory. When using in-line filters, it is necessary to have a properly grounded system providing a path for the static energy to dissipate. The system receives its ground through the power cord, which is connected to a properly grounded receptacle. A good RF connection must be made between the power control and the cabinetry.

To install the filter bulkhead bracket properly, insert a screw through both surfaces and install the appropriate size kee nut (or lockwasher and regular nut) and tighten. (Refer to the appendix for part numbers.) Tinnerman nuts should NOT be used because they do not contain lockwashers and limit the mating conductive surface area to that of the nut itself. Use a Tinnerman nut, with a lockwasher under the head of the bolt, only if no other parts are available.

Good installation procedures are necessary in order to benefit from using in-line filters. Signal and power cables should be separated as much as possible. Cables connected to the in-bound side of a filter should be separated from cables connected to the out-bound side of the filter.

The Massbus connects the CPU to large disk drives. Because of the large diameter of the Massbus, a mounting panel and zero insertion force connector were designed to hold it at right angle as it exits the cabinet (Refer to figure A-21 for part numbers.) The Massbus connector mounting panel is in the lower portion of the rear uprights of the CPU cabinet (on the right side when in a double-width cabinet).

2.5.4 Typical Cabling Configurations

Figures 2-10 through 2-14 show typical system configurations and their cabling arrangements.

2.6 CABINET REASSEMBLY

To reassemble each cabinet (refer to the appendix for part numbers):

1. Add the front vertical trim strip.
2. Hook the dress skirt (shipped loose piece) over each tab at the lower front corners of the cabinet (Figure 2-4).
3. Remount the panels and doors in the same way as they were removed. Proceed in this order.
 - a. End Panels
 - b. Top Cover
 - c. Rear Door
 - d. Front Panel

NOTE

Reconnect all ground straps.

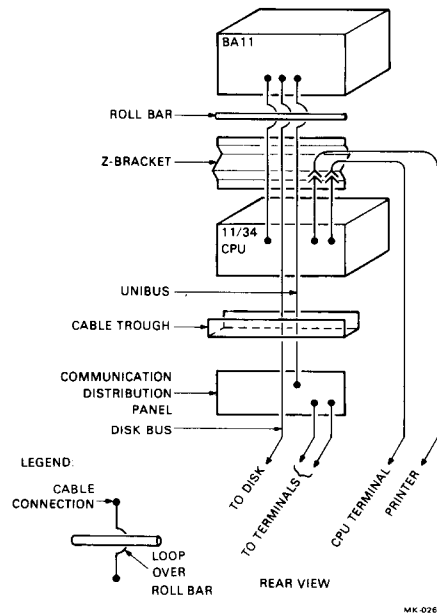

Figure 2-10 Datasystem 530 Cabling Diagram
Free-Standing Disk, Basic Configuration

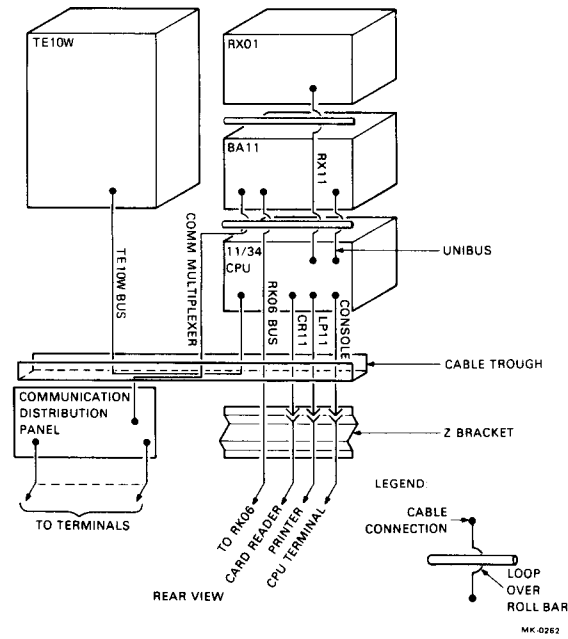

Figure 2-11 Datasystem 530 Cabling Diagram
Free-Standing RK06 Disk with TE10W Configuration

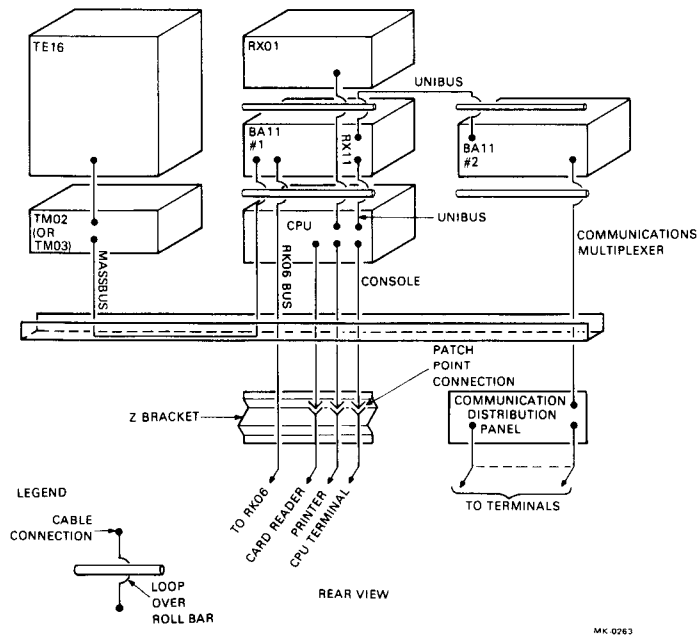

Figure 2-12 Datasystem 530 Cabling Diagram
Free-Standing RK06 Disk with TE16 Configuration

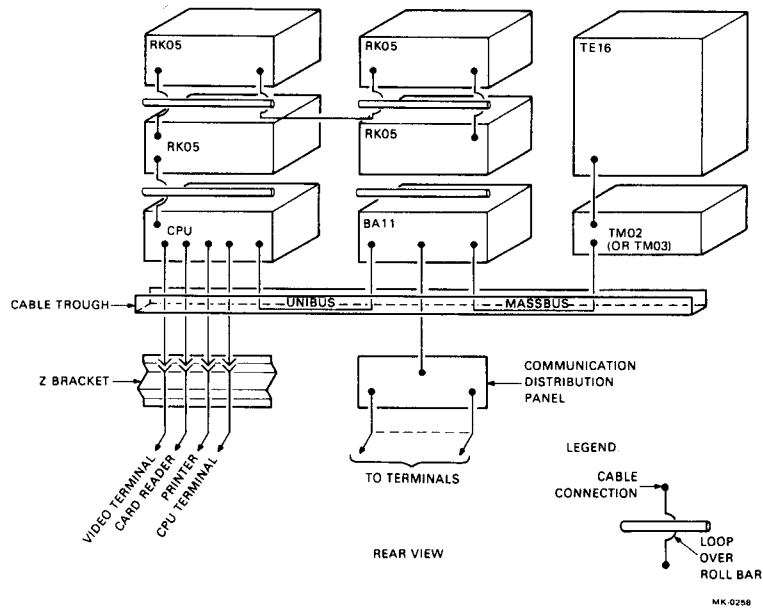

Figure 2-13 Datasystem 534 TE16 Configuration

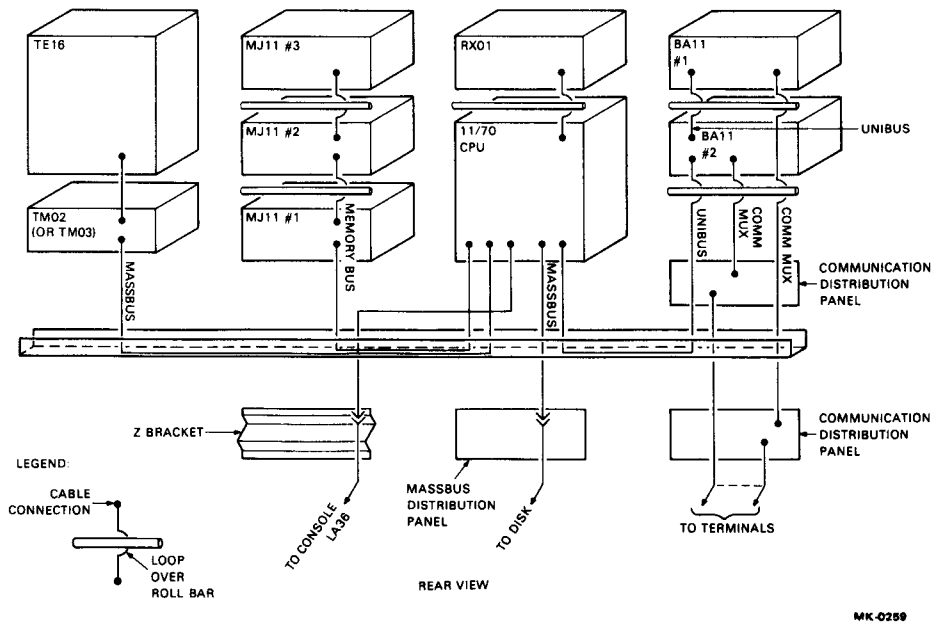

Figure 2-14 Datasystem 570 Cabling Diagram

CHAPTER 3

ACCEPTANCE AND TEST PROCEDURES

It is the responsibility of DIGITAL's Field Service group to install the equipment at the customer's site and to see that it runs at an acceptable level (free from errors). Prior to installation, the salesman and the Field Service representative should call on the customer to ensure that the location, wiring, and air conditioning are adequate for the equipment to be installed.

After the system is installed, the Field service representative will run diagnostics for each component of the machine. Each will be tested according to the acceptance procedure specified in its installation manual. Individual diagnostics must run longer if there are any errors. Diagnostics are available for each of the following devices.

- Processors
- Memory
- Bootstrap loaders
- Card readers
- Communication devices
- Processor options
- Line printers
- Paper tape readers
- Disks
- DECTape
- Video devices

DECX11 is currently the Field Service exerciser that checks maximum system hardware throughput in a worst-case situation. However, it has been found that one of the best exercises for any given machine is to run the customer's operating system. These operating systems should be run substantially longer than the individual diagnostics; the minimum run time should be 2 to 3 hours.

NOTE

These are recommendations only, and usage will vary depending on system, type, size, etc.

There is a continuing effort by DIGITAL to improve diagnostics and increase the reliability of our customer's machines. As new diagnostics are developed, the Field Service group will distribute them to the field organization.

Once the field engineer and the customer are satisfied that the machine is working correctly, the customer is required to sign an acceptance form. It is recommended that some of the customer's software be run on the equipment before it is considered in good running condition.

APPENDIX FIELD REPLACEABLE PARTS

For a list of all drawings in this appendix, refer to page iv.

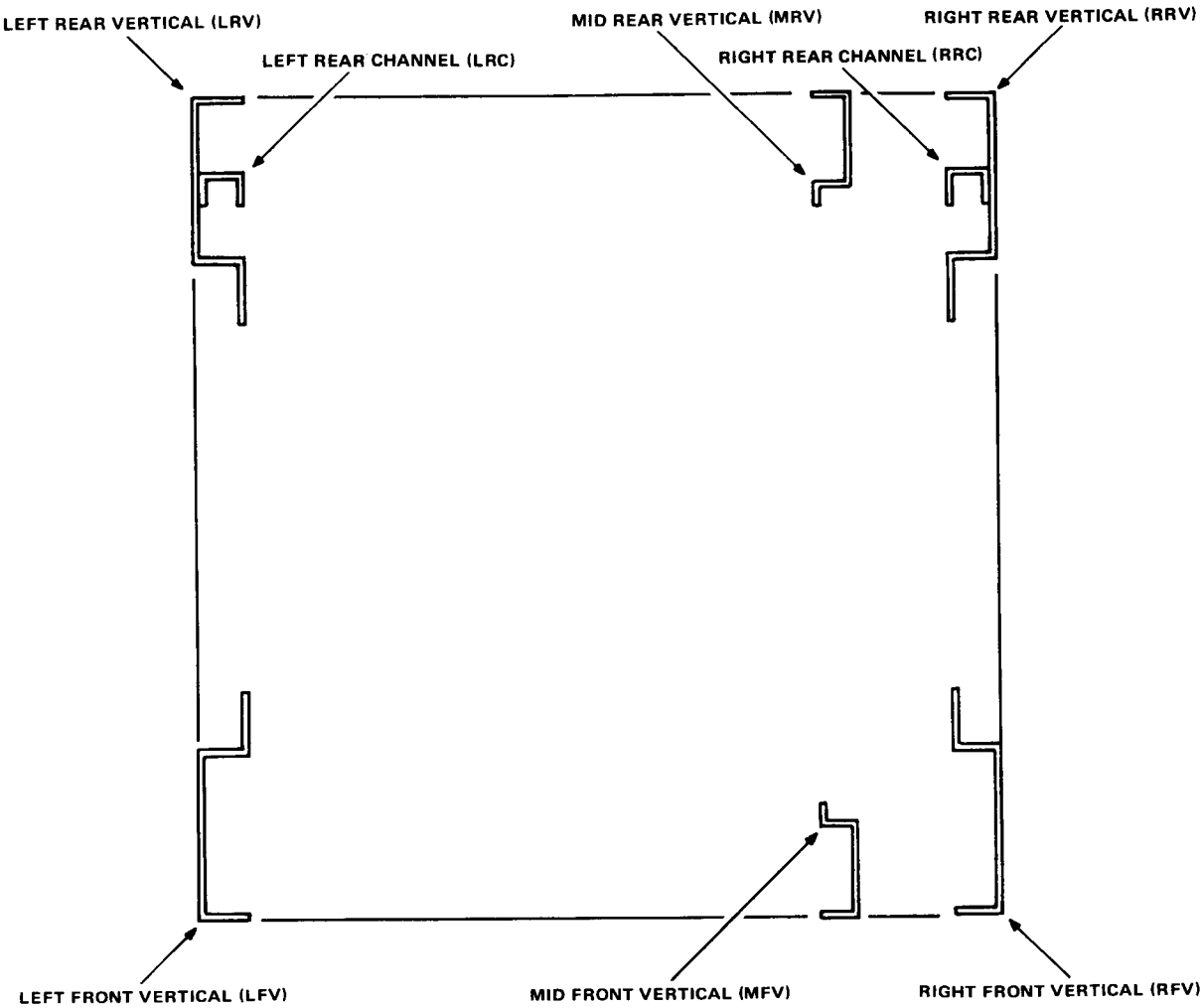

MA-0362

NOTE Use this drawing with the unit hole location charts.

Figure A-1 H9500 Cabinet - Top View

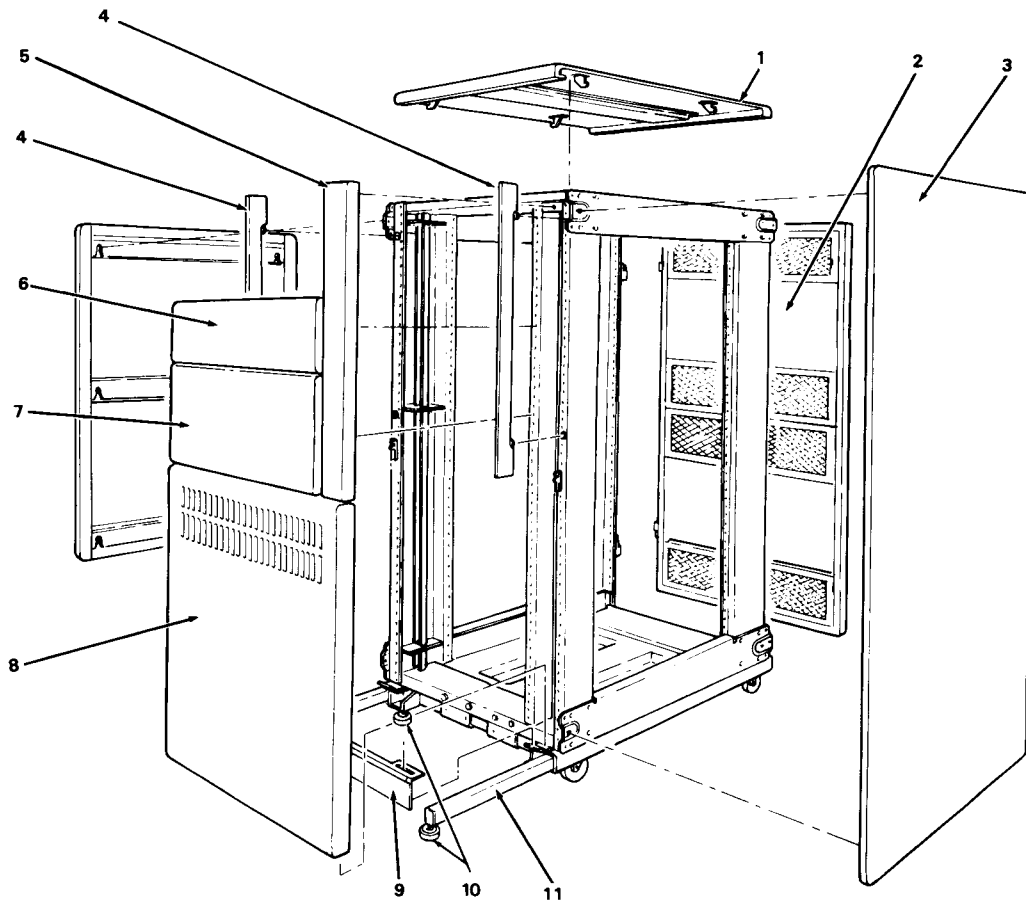

11	STABILIZER ARM	74-14087-0-0	2
10	LEVELER FOOT	90-00022-01	6
9	DRESS SKIRT	12-14810-00	1
8	FRONT COVER, 28 in.	70-12249-01	1
7	FILLER PANEL, 10 1/2 in.	74-15314-00	1
6	FILLER PANEL, 5 1/4 in.	74-15313-00	1
5	FILLER PANEL, 26 1/2 in.	74-15771-03	1
4	TRIM STRIP	70-11638-00	2
3	END PANEL	70-11509-00	2
2	REAR DOOR, 16 louvers	70-14175-00	1
2	REAR DOOR, 8 louvers	70-12244-00	1
1	TOP COVER	70-11552-01	1
ITEM	DESCRIPTION	DWG.PART NO.	QTY.

MK-0578

Figure A-2 H9502 Single-width Hiboy Cabinet with 28 Inch Front Cover

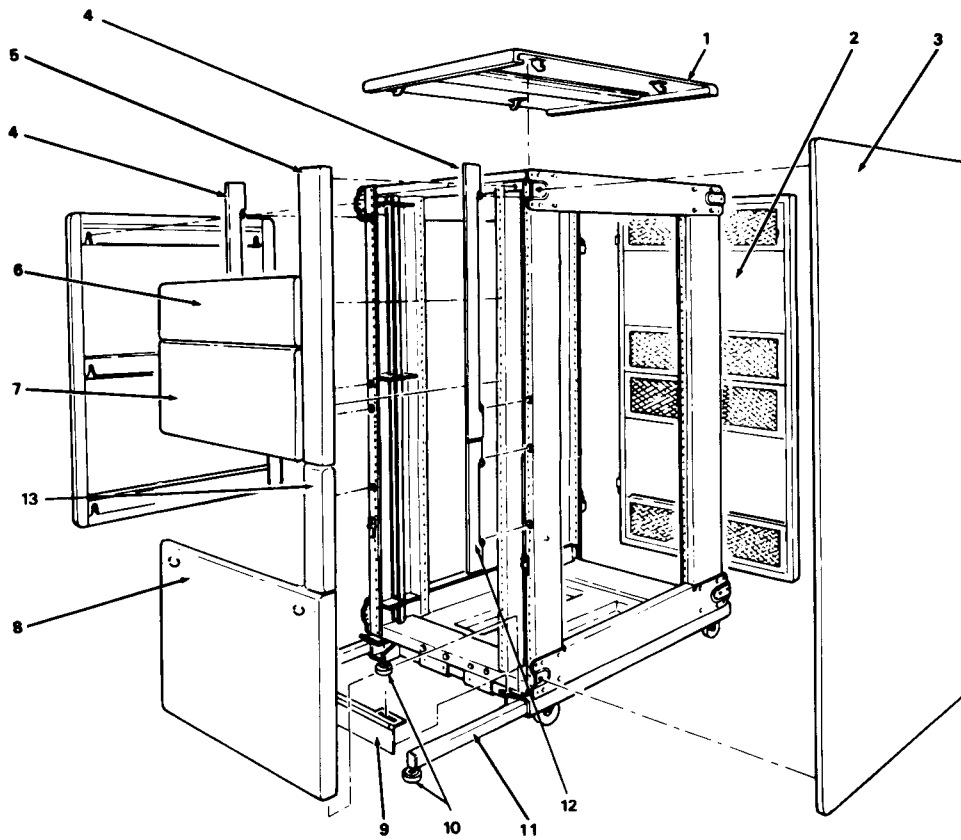

13	FILLER PANEL, 15 3/4 in.	74-15771-01	1
12	TRIM STRIP	1212964-00	2
11	STABILIZER ARM	74-14087-0-0	2
10	LEVELER FOOT	90-00022-01	6
9	DRESS SKIRT	12-14810-00	1
8	FRONT COVER, 12 in.	70-15709-00	1
7	FILLER PANEL, 10 1/2 in.	74-15314-00	1
6	FILLER PANEL, 5 1/4 in.	74-15313-00	1
5	FILLER PANEL, 26 1/2 in.	74-15771-03	1
4	TRIM STRIP	70-11638-00	2
3	END PANEL	70-11509-00	2
2	REAR DOOR, 16 louvers	70-14175-00	1
2	REAR DOOR, 8 louvers	70-12244-00	1
1	TOP COVER	70-11552-01	1
ITEM	DESCRIPTION	DWG PART NO.	QTY.

MK-0616

Figure A-3 H9502 Single-width Hiboy Cabinet with 12 Inch Front Cover

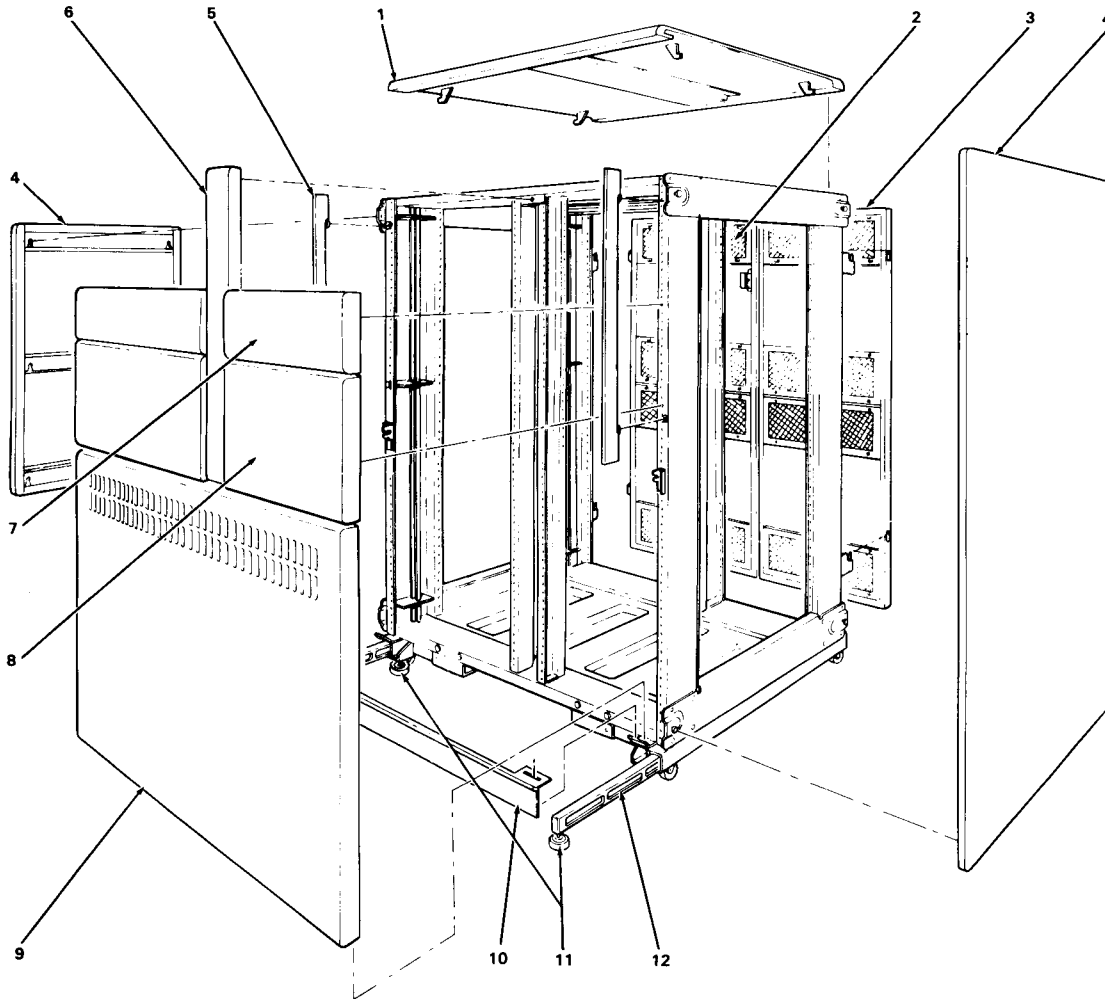

Replaceable Rear Door Filters

DOOR TYPE	FILTER PART #
8 LOUVER DOOR	12-13096-00
16 LOUVER DOOR	RT HD - BOTTOM 12-12035-01
	TOP 12-12035-02
	LT HD - BOTTOM 12-12035-01
	TOP 12-12035-03

12	STABILIZER ARM	74-14087-0-0	2
11	LEVELER FOOT	90-00022-01	6
10	DRESS SKIRT	12-14810-01	1
9	FRONT COVER, 28 in.	70-12221-01	1
8	FILLER PANEL, 10 1/2 in.	74-15314-00	2
7	FILLER PANEL, 5 1/4 in.	74-15313-00	2
6	FILLER PANEL, 26 1/2 in.	74-15771-03	1
5	TRIM STRIP	70-11638-00	2
4	END PANEL	70-11509-00	2
3	LEFT DOOR, LT HD, 16 louvers	70-14306-00	1
3	REAR DOOR, 8 louvers	70-12245-00	1
2	REAR DOOR, RT HD, 16 louvers	70-14346-00	1
2	REAR DOOR, 8 louvers	70-12246-00	1
1	TOP COVER	70-11552-00	1
ITEM	DESCRIPTION	DWG PART NO.	QTY

MK-0582

Figure A-4 H9500 Double-width Hiboy Cabinet

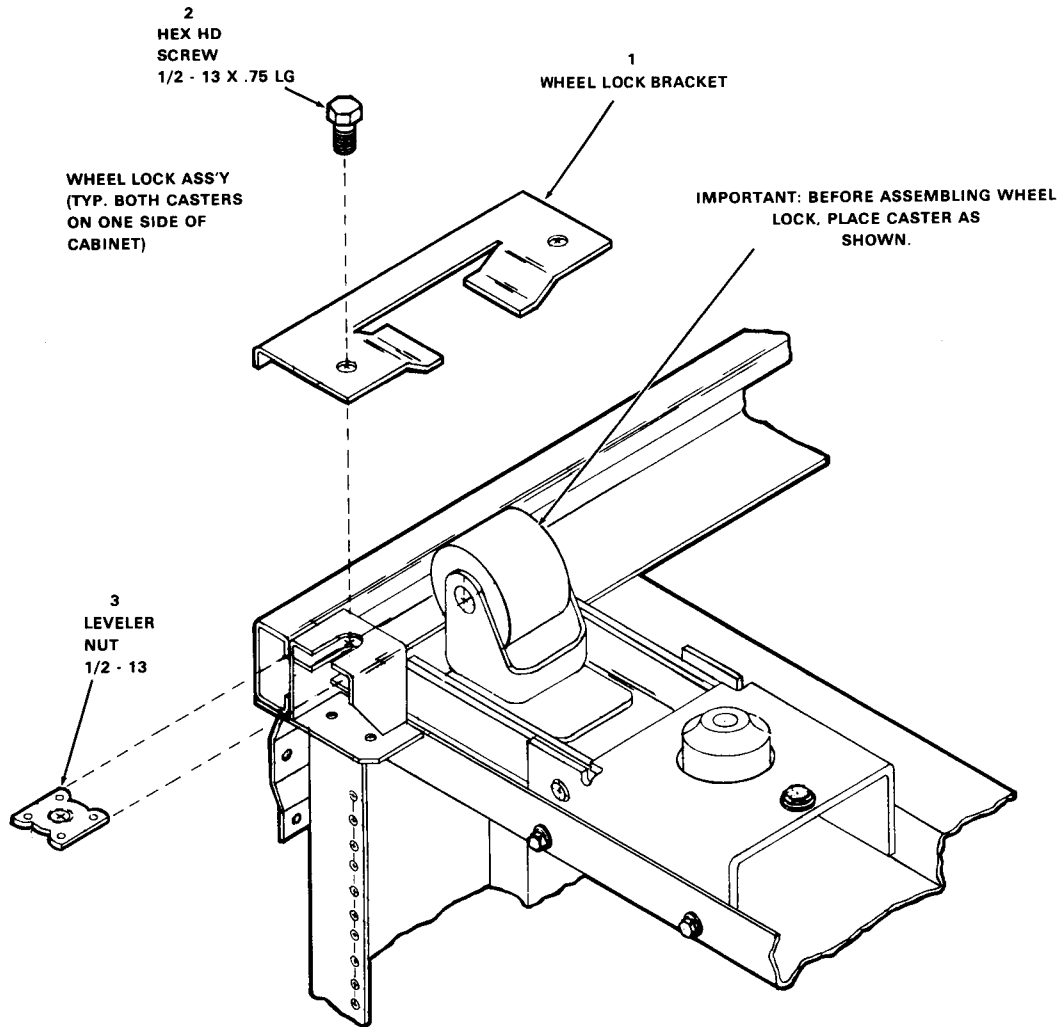

3	LEVELER NUT	9008878-00	1
2	HEX HD. SCREW	9000043-02	1
1	WHEEL LOCK BRACKET	7417593-0-0	1
ITEM	DESCRIPTION	DWG PART NO.	QTY

MK-0572

Figure A-5 Wheel Lock Assembly

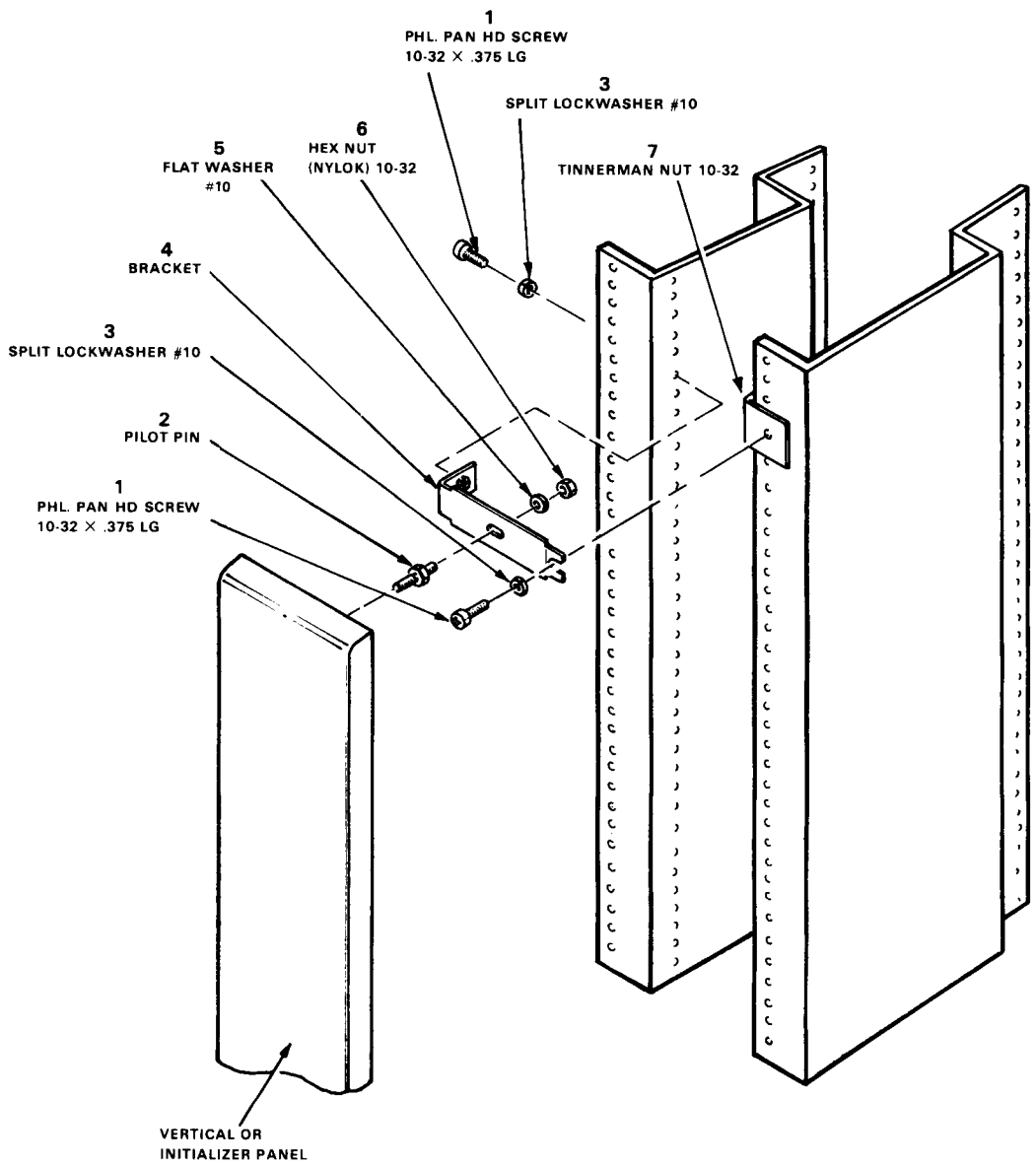

UNIT HOLE LOCATION

PRIM. LOC.	SEC. LOC.	LRV	LRC	LFV	MRV	MFV	RRV	RRC	RFV
1						48			48
						88			88

REFER TO FIGURE A-1

ITEM	DESCRIPTION	DWG PART NO	QTY
7	TINNERMAN NUT	9007786-00	2
6	HEX NUT (NYLOK)	9008059-00	2
5	FLAT WASHER	9006664-00	2
4	BRACKET, MTG.	C-IA-7416797-01	2
3	LOCKWASHER	9007906-00	4
2	PIN, PILOT	B-MD-7415711-0-0	2
1	PHL PAN HD SCREW	9006071-01	4
ITEM	DESCRIPTION	DWG PART NO	QTY

MK-0341

Figure A-6 Vertical Panel for Single-width Hiboy Cabinet (H9602)

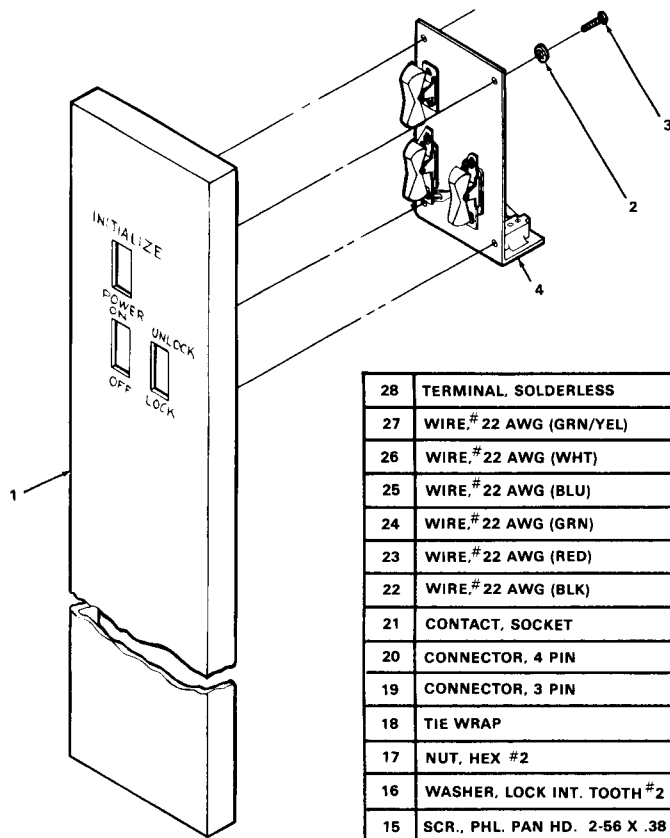

NOTES:
 1. INSTALL SWITCHES (ITEM 5)
 SO KNOB IS ACTIVATED
 DOWNWARD AGAINST
 MOMENTARY SPRING.
 2. WIRE (ITEM 27) IS TO BE
 12.0 INCHES LG.

28	TERMINAL, SOLDERLESS	9007930-00	1
27	WIRE, # 22 AWG (GRN/YEL)	9107400-54	A/R
26	WIRE, # 22 AWG (WHT)	9107350-99	A/R
25	WIRE, # 22 AWG (BLU)	9107350-66	A/R
24	WIRE, # 22 AWG (GRN)	9107350-55	A/R
23	WIRE, # 22 AWG (RED)	9107350-22	A/R
22	WIRE, # 22 AWG (BLK)	9107350-00	A/R
21	CONTACT, SOCKET	1209379-03	6
20	CONNECTOR, 4 PIN	1209350-04	1
19	CONNECTOR, 3 PIN	1209350-03	1
18	TIE WRAP	9007031-00	A/R
17	NUT, HEX #2	9006555-00	4
16	WASHER, LOCK INT. TOOTH #2	9006631-00	4
15	SCR., PHL. PAN HD. 2-56 X .38 LG	9006003-01	4
14	WASHER, FLAT #2	9008877-00	4
13	SPACER	B-MD-7414319-0-0	4
12	ROCKER	1205317-08	3
11	SWITCH, LATCH	C-MD-7414321-0-0	1
10	SWITCH, HASP	C-MD-7414322-0-0	2
9	WASHER, LOCK # 4	9006688-00	6
8	NUT, HEX 4-40	9009280-00	6
7	SCR., PHL. FLAT HD. 4-40 x .312 LG	9006010-02	6
6	SWITCH D.P.D.T.	B-MD-7411297-2-0	1
5	SWITCH S.P.S.T.	B-MD-7411299-1-0	2
4	BRACKET, SWITCH	D-MD-7417030-0-0	1
3	SCR., PHL. PAN HD. 6-32 X .25 LG.	9006020-01	4
2	WASHER, SPRING LOCK # 6	9007801-00	4
1	BEZEL, VERTICAL w/S.S.	D-IA-7417670-0-0	1
ITEM	DESCRIPTION	DWG/PART NO.	QTY

MK-0573

Figure A-7 Initializer Panel (1 of 3)

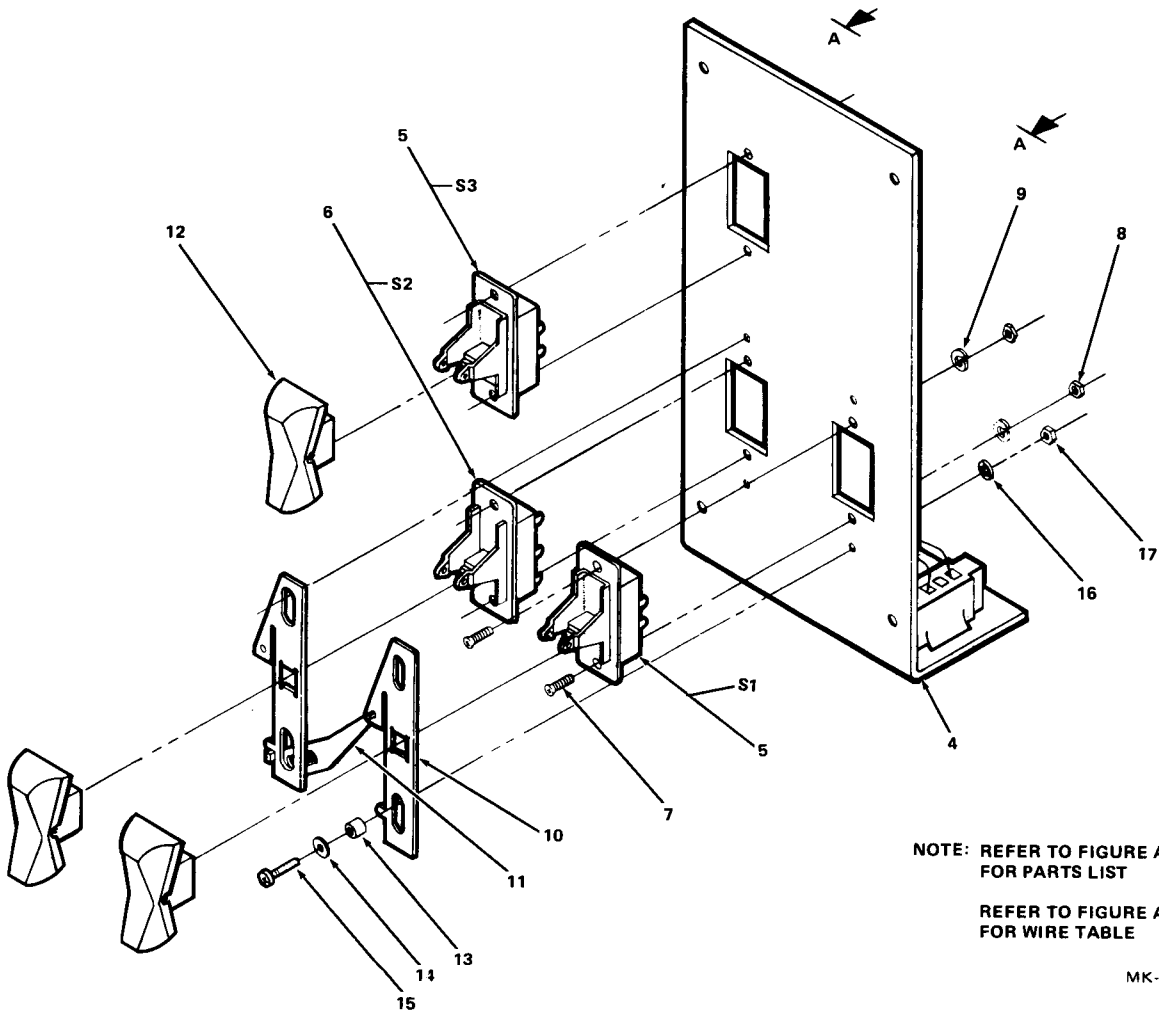

NOTE: REFER TO FIGURE A-6
FOR PARTS LIST

REFER TO FIGURE A-8
FOR WIRE TABLE

MK-0574

Figure A-8 Initializer Panel (2 of 3)

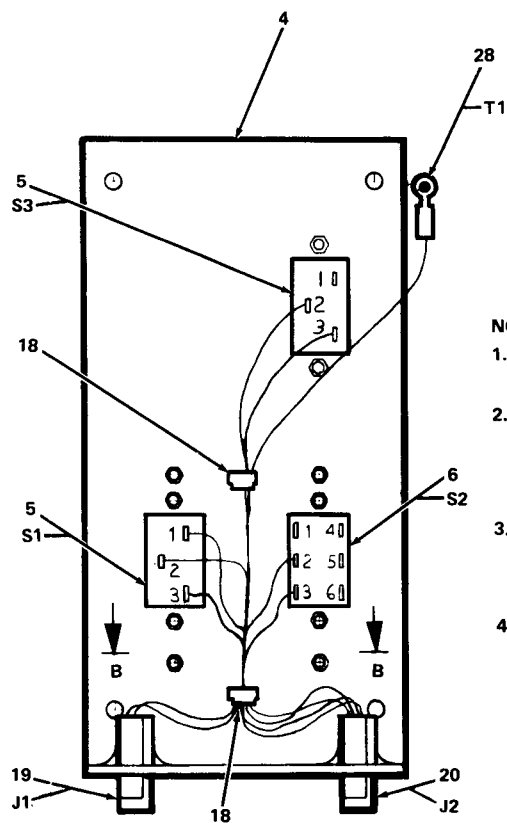

NOTES:

1. REFER TO FIGURE A-6 FOR PARTS LIST
2. INSTALL SWITCHES (ITEM 5) SO KNOB IS ACTIVATED DOWNWARD AGAINST MOMENTARY SPRING.
3. CONNECT J1 TO THE DEC POWER CONTROL BUS USING CABLE #7008288
4. CONNECT J2 TO TP2 AND TP3 OF THE M9301 BOOT MODULE USING CABLE 7013519 ; OR CONNECT J2 TO TP1 (BLACK WIRE) AND TP2 (CLEAR GROUND WIRE) OF THE M9312 BOOT MODULE USING CABLE # 7013520

WIRE TABLE						
ITEM NO.	DESCRIPTION		FROM		TO	
	AWG	COLOR	CONN	WITH	CONN	WITH
22	22	BLK	J2-4	21	S1-1	SOLDER
25	22	BLU	J2-2	21	S3-3	↑ ↓
26	22	WHT	J2-1	21	S1-3	
24	22	GRN	J1-3	21	S2-2	
23	22	RED	J1-1	21	S2-3	↓
25	22	BLU	S1-2	SOLDER	S3-2	SOLDER
27	22	GRN/YEL	J2-3	21	T1	28

MK-0571

Figure A-9 Initializer Panel (3 of 3)

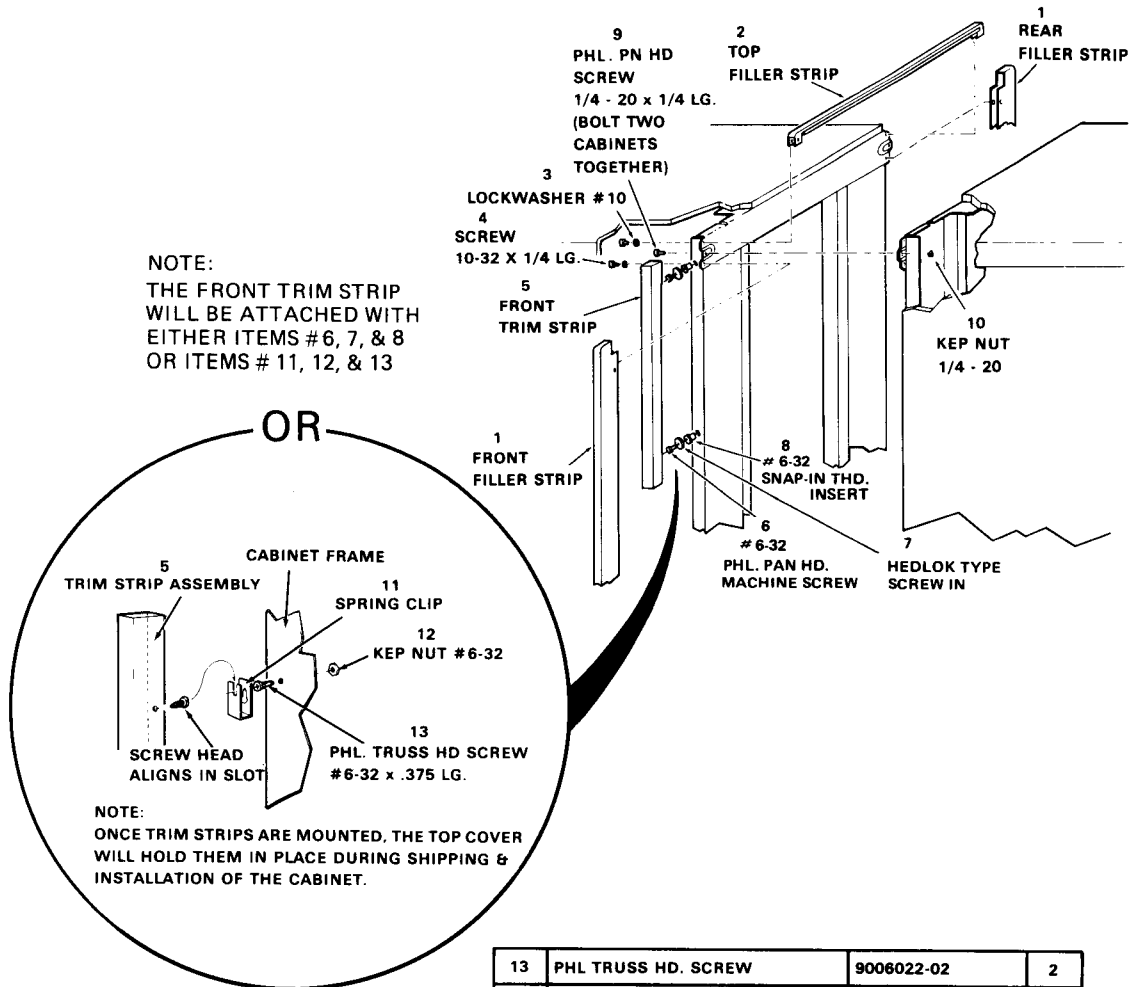

13	PHL TRUSS HD. SCREW	9006022-02	2
12	KEP NUT	9006560-00	2
11	SPRING CLIP	B-MD-7422258-0-0	2
10	KEP NUT	9008023-00	4
9	PHL PN HD SCREW	9009453-0	4
8	SNAP-IN THREADED INSERT	9009789-00	2
7	HEDLOK TYPE SCREW IN	9009712-00	2
6	PHL. PAN HD. MACHINE SCREW	9006023-1	2
5	TRIM STRIP ASSY.	D-IA-7011838-1-0	1
4	PHL. PAN HD. SCREW	9008007-01	8
3	EXT. TOOTH LOCKWASHER	9007651-00	8
2	TOP FILLER STRIP	D-MD-7414403-0-0	1
1	FILLER STRIP ASSY	D-IA-7011838-0-0	2
ITEM	DESCRIPTION	DWG. PART NO.	QTY

MK-0617

Figure A-10 Trim Strip and Intercabinet Filler Strips

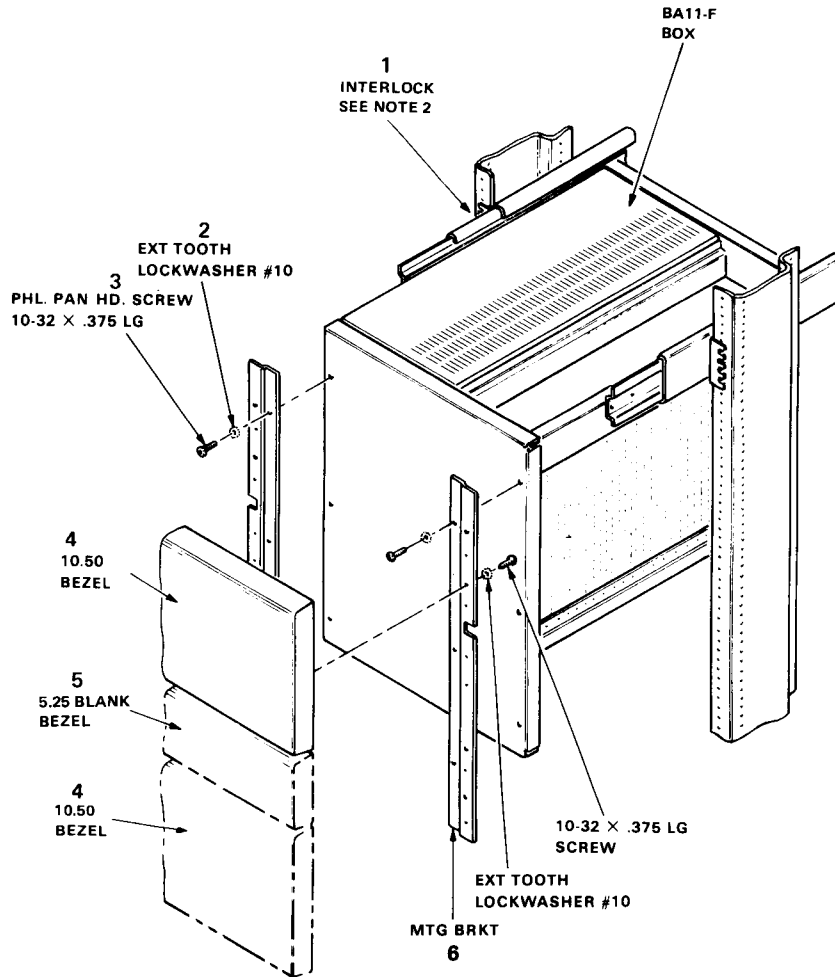

NOTE:

1) WHEN BA11-F IS BEHIND FRONT COVER, ONLY ONE 10-1/2 BEZEL IS REQ'D; WHEN BA11-F IS MOUNTED ABOVE FRONT COVER AN ADDITIONAL 10-1/2 AND 5-1/4 BEZEL IS REQ'D.

2) FOR INTERLOCK ASS'Y SEE DRAWING 7013688. LOCATION OF CHURCH KEY = D62.

UNIT HOLE LOCATION

UNIT	PRIM. LOC.	SEC. LOC.	LRV	LRC	LRV	MRV	MFV	RRV	RRC	RFV
SLIDES	1			59	59	59	59			
				60	60	60	60			
				62	62	62	62			
POWER SUPPLY	1								39	39
									42	42
									48	48
									51	51

REFER TO FIGURE A-1

ITEM	DESCRIPTION	DWG PART NO	QTY
6	MOUNTING BRACKET	D-MD-7417164-0-0	2
5	BEZEL	E-MD-7415313-0-0	A/R
4	BEZEL	E-AD-7415314-0-0	1
3	PHL PAN HD SCREW	9008071-01	10
2	EXT TOOTH LOCKWASHER	9007849	10
1	INTERLOCK KIT	E-AD-7013688-0-0	1

MK-0342

Figure A-11 BA11-F Front Covers

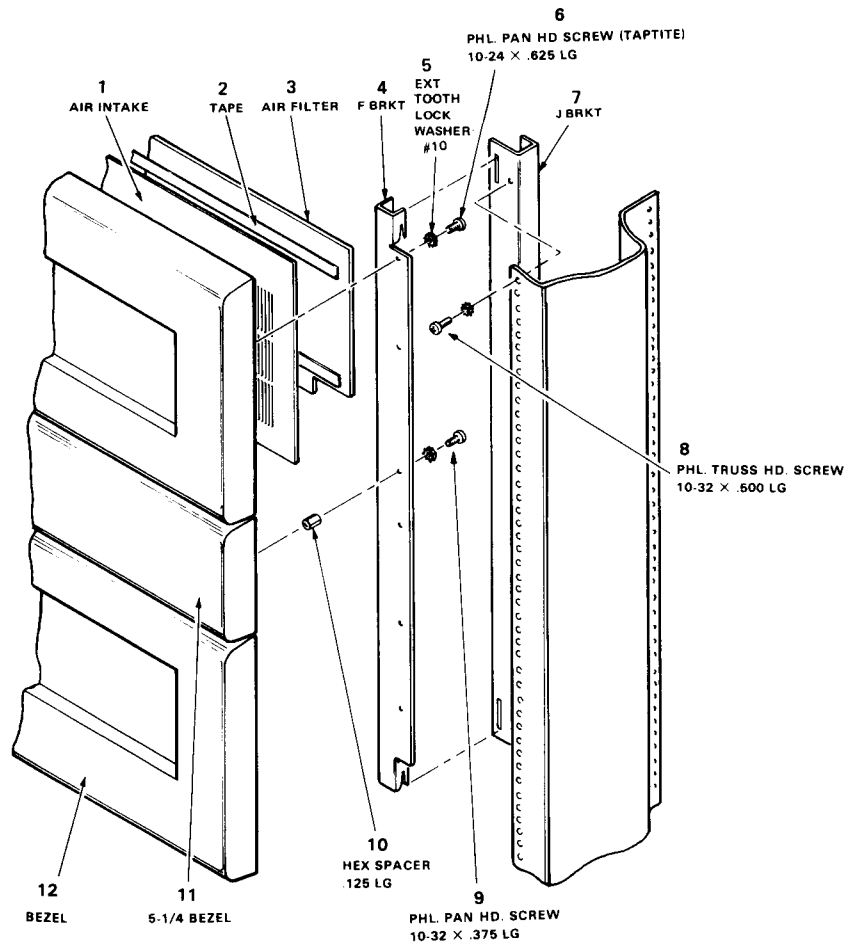

NOTES

1. 3 PANEL FRONT COVER CAN BE REMOVED ONLY AFTER REMOVING CABINET TOP COVER.
2. USED TO COVER LOGIC PANELS IN TOP HALF OF CABINET. USED ON RP11.

UNIT HOLE LOCATION									
PRIM. LOC.	SEC. LOC.	LRV	LRC	LFV	MRV	MFV	RRV	RRC	RFV
1				48		48			
				61		61			
				75		75			
				88		88			

REFER TO FIGURE A-1

ITEM	DESCRIPTION	DWG PART NO	QTY
12	BEZEL RX01. (DIE CASTING)	E-MD-7414606-0-0	2
11	5-1/4 BEZEL	E-MD-7416313-0-0	1
10	SPACER, HEX	9008825-00	4
9	PHL PAN HD SCR	9008071-01	4
8	PHL TRUSS HD SCR	9008073-03	4
7	J BRACKET	D-IA-7416936-0-0	2
6	PHL PAN HD SCREW (TAPTITE)	9009813-00	8
5	EXT TOOTH LOCKWASHER	9007651-00	20
4	BRACKET, F. (R.H.)	D-IA-7416937-1-0	1
4	BRACKET F. (L.H.)	D-IA-7416937-0-0	1
3	AIR FILTER BEZEL	C-PS-1213246-0-0	2
2	TAPE AIR FILTER	1211338-02	A/R
1	AIR INTAKE	D-IA-7415743-0-0	2
ITEM	DESCRIPTION	DWG PART NO	QTY

MK-0343

Figure A-12 3-Panel Front Cover

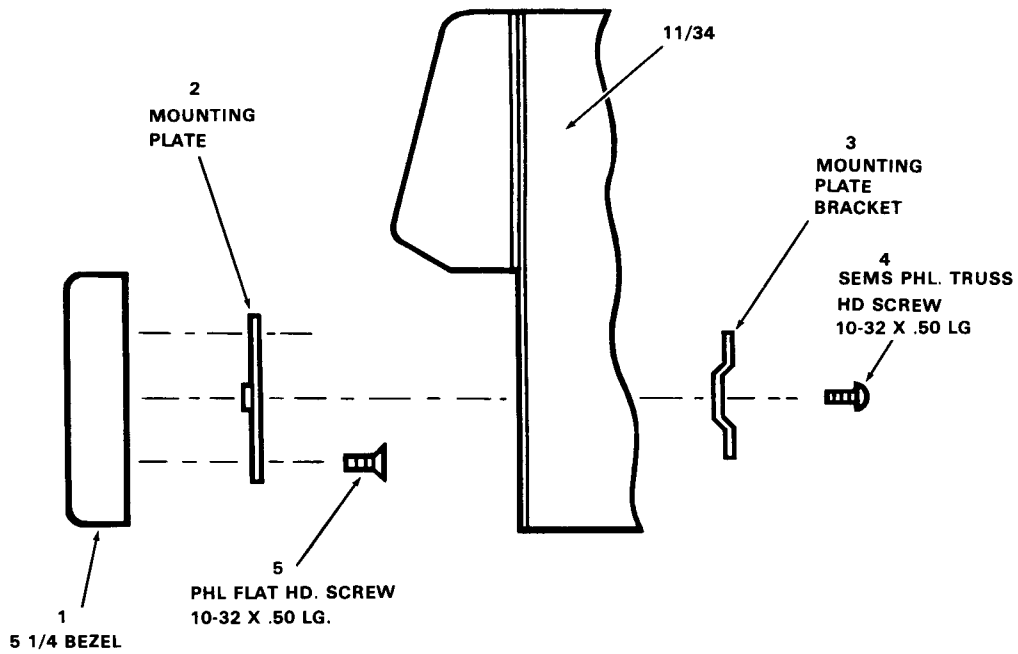

5	PHL. FLAT HD. SCREW	9006073-02	4
4	SEMS PHL. TRUSS HD. SCREW	9009700-00	2
3	BRACKET PLATE MTG.	C-MD-7420954-0-0	2
2	PLATE PANEL MTG.	C-IA-7420953-0-0	2
1	5 1/4 BEZEL	E-MD-7415313-00	1
ITEM	DESCRIPTION	DWG. PART NO.	QTY.

MK-0583

Figure A-13 5 1/4 Bezel For 11/34

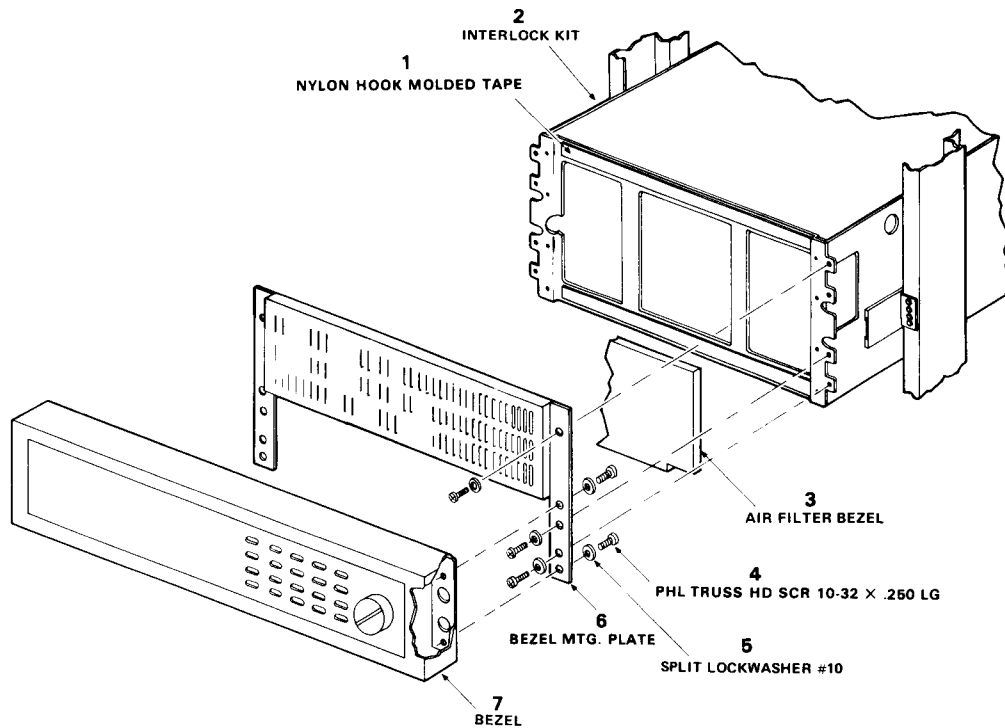

- NOTES:
 1. FOR INTERLOCK ASSEMBLY SEE DRAWING 7013688. INTERLOCK LOCATION D29.
 2. FOR COMPLETE CONSOLE ASSEMBLY SEE DRAWING 7013517.

UNIT HOLE LOCATION									
PRIM. LOC.	SEC. LOC.	LRV	LRC	LFV	MRV	MFV	RRV	RRC	RFV
1		26		26	26	26			
		28		28	28	28			
		29		29	29	29			

REFER TO FIGURE A-1

ITEM	DESCRIPTION	DWG PART NO	QTY
7	BEZEL	D-1A-7417662-0-0	1
6	PLATE, BEZEL MTG.	D-MD-7417663-0-0	1
5	SPLIT LOCKWASHER	9007906	10
4	PHL TRUSS HD SCR	9008007-03	10
3	AIR FILTER BEZEL	1213246-0-0	1
2	INTERLOCK KIT	E-AD-7013688-0-0	1
1	TAPE, NYLON HOOK MOLDED	1211336-02	A/R

MK-0577

Figure A-14 PDP-11/34 Sheet Metal Bezel

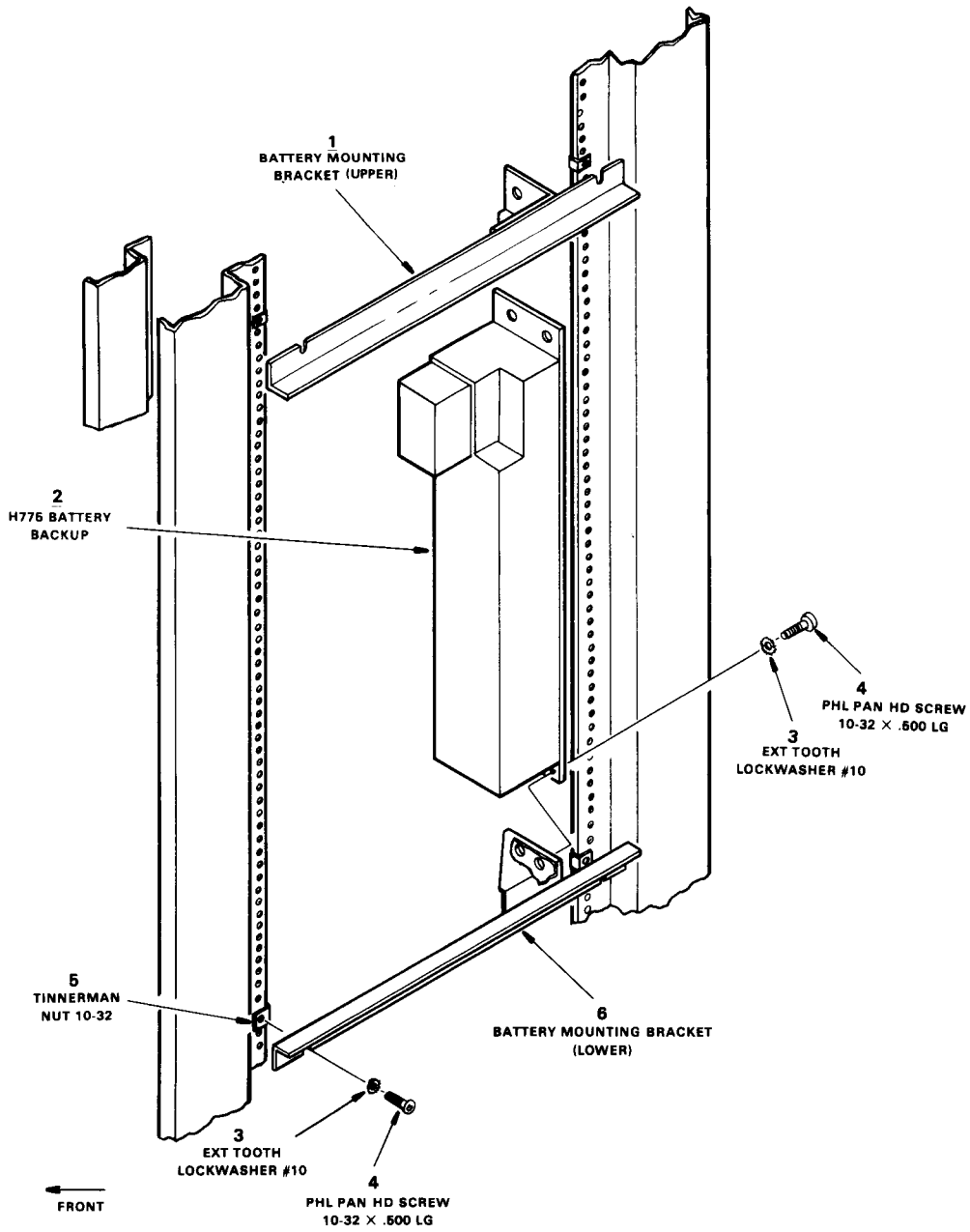

6	BRACKET, BATTERY MTG (LOWER)	D-IA-7015238-0-0	1
5	TINNEMAN NUT	9007786	4
4	PHL PAN HD SCREW	9008073-01	8
3	EXT TOOTH LOCKWASHER	9007651	8
2	H776 BATTERY BACKUP	E-UA-H776-0-0	1
1	BRACKET, BATTERY MTG (UPPER)	D-IA-7015238-0-1	1
ITEM	DESCRIPTION	DWG/PART NO.	QTY

UNIT HOLE LOCATION									
PRIM. LOC.	SEC. LOC.	LRV	LRC	LFV	MRV	MFV	RRV	RRC	RFV
1							17		17
							51		51

REFER TO FIGURE A-1

MK-0584

Figure A-15 Battery Back-Up for the PDP-11/34 System

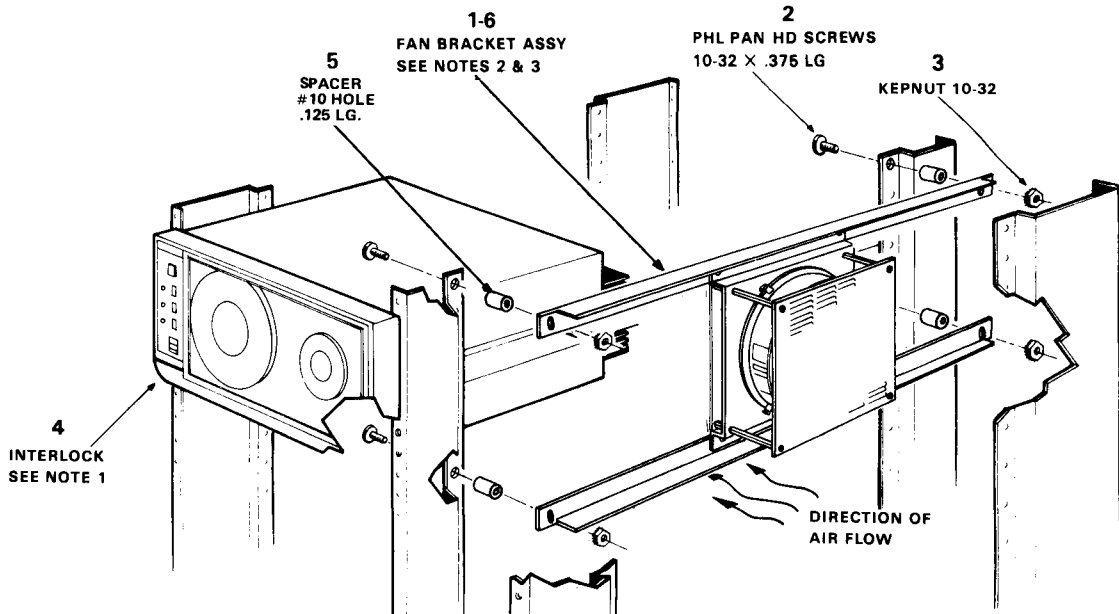

- NOTES**
1. FOR INTERLOCK ASSEMBLY SEE DRAWING 7013688. LOCATION OF CHURCH KEY = US84 OR U53.
 2. POSITION FAN TO GIVE OPTIMUM AIR ACROSS TS03 HEAT SINK.

ITEM	DESCRIPTION	DWG PART NO	QTY	
			115V SYSTEM	230V SYSTEM
6	FAN ASSEMBLY	D-AD-7016010-01		1
5	SPACER	9008825	4	4
4	INTERLOCK KIT	E-AD-7013688-0-0	1	1
3	KEPNUT	9006665	4	4
2	PHL PAN HD SCREW	9006071-01	4	4
1	FAN ASSY	D-AD-7016010-00	1	

UNIT HOLE LOCATION	PRIM. LOC.	SEC. LOC.	LRV	LRC	LFV	MRV	MFV	RRV	RRC	RFV
TS03	1		53		53	53	53			
			54		54	54	54			
TS03		1	84		84	84	84			
			85		85	85	85			
FAN ASSY	1					47	47			
FAN ASSY		1				60	60			
						75	75			
						88	88			

REFER TO FIGURE A-1

MK-0338

Figure A-16 Fan Assembly for TS03 Magnetic Tape Unit

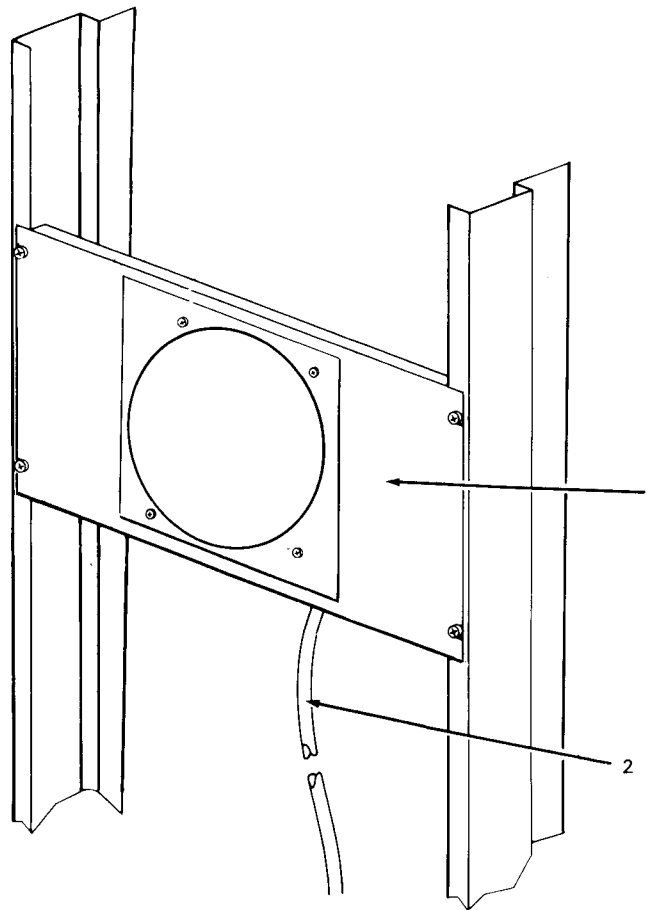

REAR of Cab

NOTE: Remove filter from fan before installing fan assembly.

			115V	230V
2	POWER CORD	1700016-09		1
2	POWER CORD	1700006-09	1	
1	FAN ASSEMBLY	H957-HB		1
1	FAN ASSEMBLY	H957-HA	1	
ITEM	DESCRIPTION	DWG PART NO.	QTY.	QTY.

MK-0618

Figure A-17 H957 Fan Assembly (Used in 11/70 based systems)

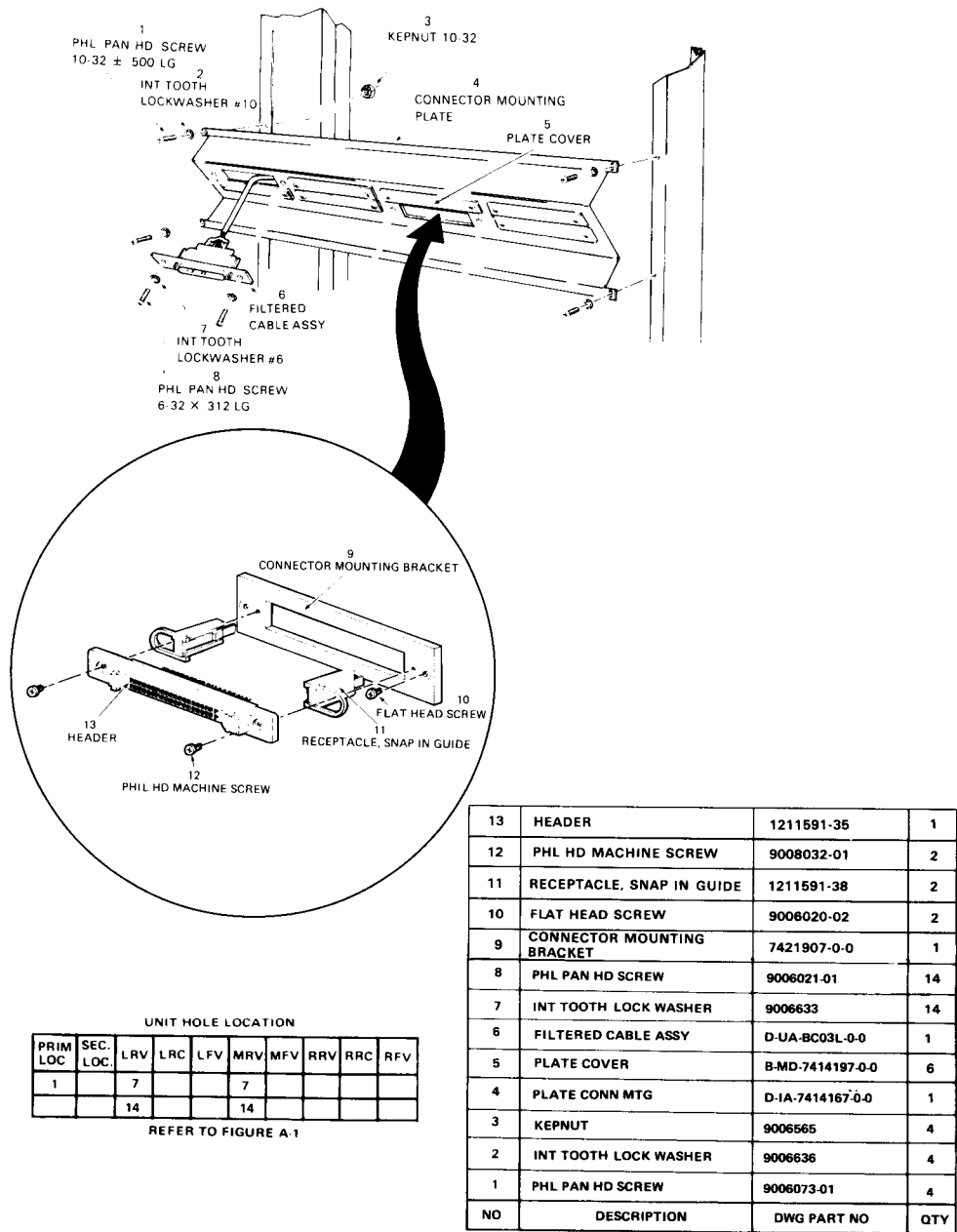

UNIT HOLE LOCATION									
PRIM LOC	SEC. LOC.	LRV	LRC	LFV	MRV	MFV	RRV	RRC	RFV
1		7			7				
		14			14				

REFER TO FIGURE A.1

NO	DESCRIPTION	DWG PART NO	QTY
13	HEADER	1211591-35	1
12	PHL HD MACHINE SCREW	9008032-01	2
11	RECEPTACLE, SNAP IN GUIDE	1211591-38	2
10	FLAT HEAD SCREW	9006020-02	2
9	CONNECTOR MOUNTING BRACKET	7421907-0-0	1
8	PHL PAN HD SCREW	9006021-01	14
7	INT TOOTH LOCK WASHER	9006633	14
6	FILTERED CABLE ASSY	D-UA-BC03L-0-0	1
5	PLATE COVER	B-MD-7414197-0-0	6
4	PLATE CONN MTG	D-IA-7414167-0-0	1
3	KEPNUT	9006565	4
2	INT TOOTH LOCK WASHER	9006636	4
1	PHL PAN HD SCREW	9006073-01	4
NO	DESCRIPTION	DWG PART NO	QTY

MK-0620

Figure A-18 Connector Mounting Plate (Z Bracket)

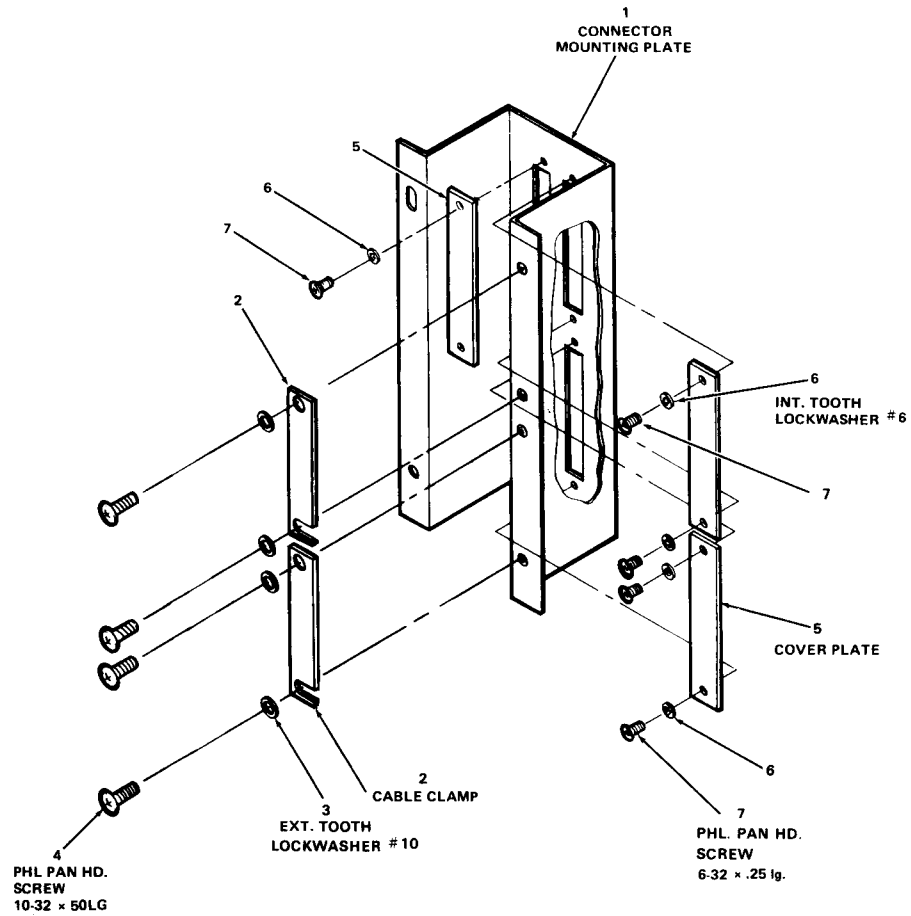

UNIT HOLE LOCATION									
PRIM. LOC.	SEC. LOC.	LRV	LRC	LFV	MRV	MFV	RRV	RRC	RFV
1					12		12		
					25		25		

REFER TO FIGURE A-1

7	SCR. PH. PAN. HD.	9006020-01	6
6	WASHER INT. TOOTH LOCK	9006633-00	6
5	PLATE, COVER	B-MD-7414197-0-0	3
4	SCR. PH. PAN HD.	9006073-01	4
3	EXT. TOOTH LOCKWASHER	9007651-00	4
2	CLAMP, CABLE	C-MD-7415643-0-0	2
1	PLATE, CONN. MTG.	D-IA-7420952-0-0	1
ITEM	DESCRIPTION	DWG./PART NO.	QTY.

MK-0576

Figure A-19 Vertical Connector Mounting Plate

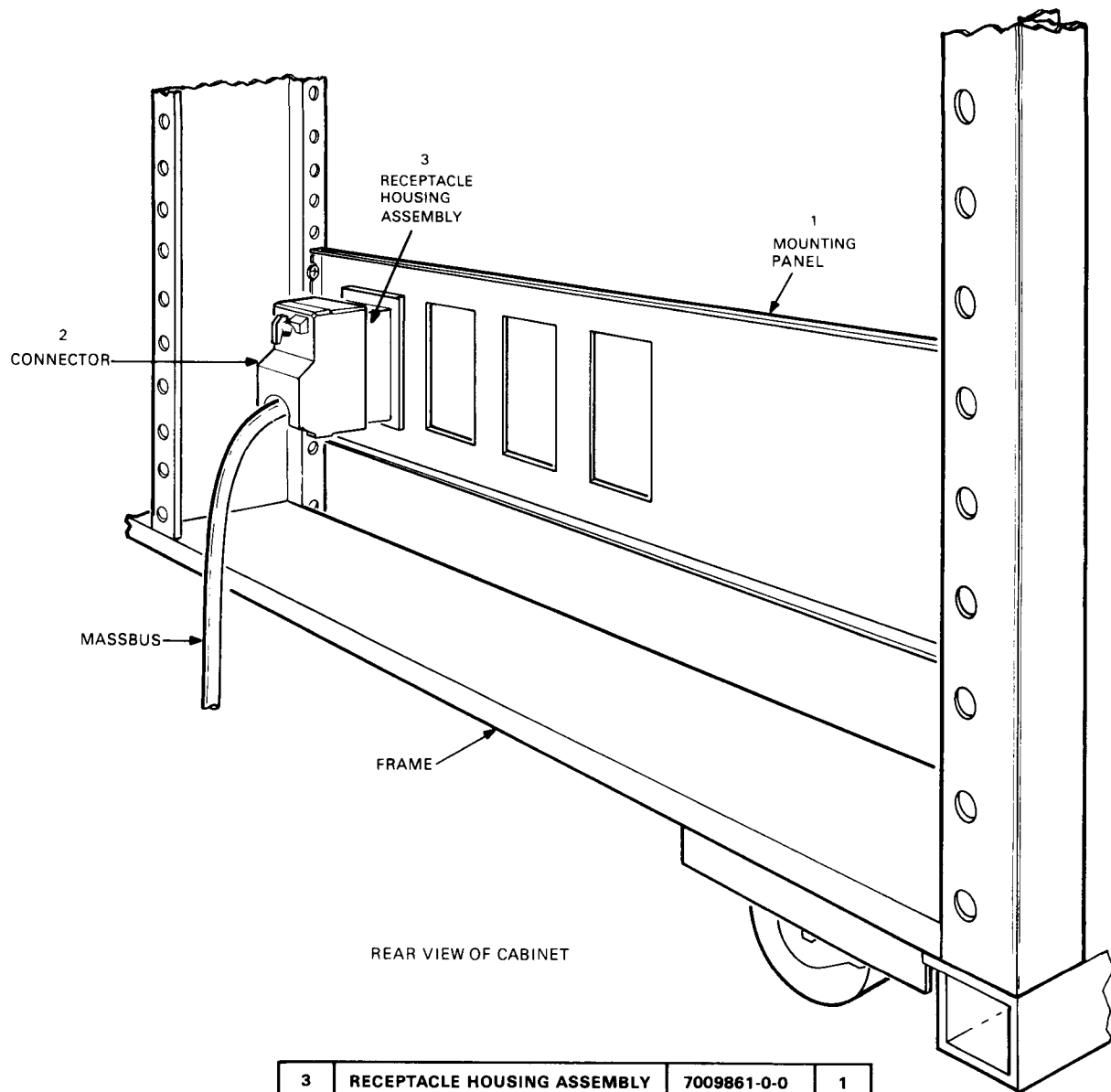

3	RECEPTACLE HOUSING ASSEMBLY	7009861-0-0	1
2	MASSBUS & CABLE CONNECTOR	BC06S-25	1
1	MOUNTING PANEL	70-10574	1
ITEM	DESCRIPTION	DWG PART NO	QTY

CP-2871

Figure A-20 Massbus Connector and Mounting Panel

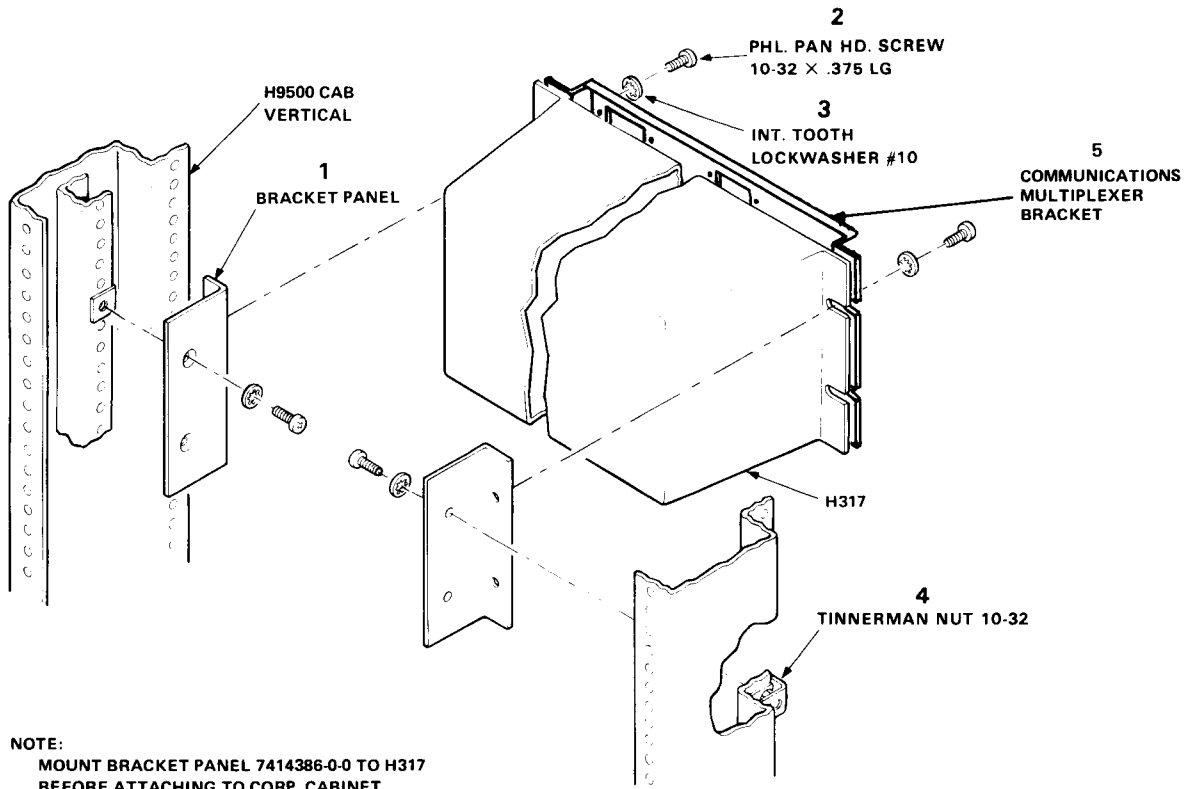

NOTE:
MOUNT BRACKET PANEL 7414386-0-0 TO H317
BEFORE ATTACHING TO CORP. CABINET.

UNIT HOLE LOCATION

PRIM. LOC.	SEC. LOC.	LRV	LRC	LFV	MRV	MFV	RRV	RRC	RFV
1		8			8				
		12			12				
	2	30			30				
		34			34				
	3	52			52				
		56			56				

REFER TO FIGURE A-1

ITEM	DESCRIPTION	DWG PART NO	QTY
5	COMM MULT BRACKET	7415808	1
4	TINNERMAN NUT	9007786	4
3	INT TOOTH LCK WASHER	9006636	8
2	PHL PAN HD SCREW	9006071-01	8
1	BRACKET PANEL	C-MD-7414386-0-0	2

MK-0344

Figure A-21 H317 Distribution Panel Mounting Hardware

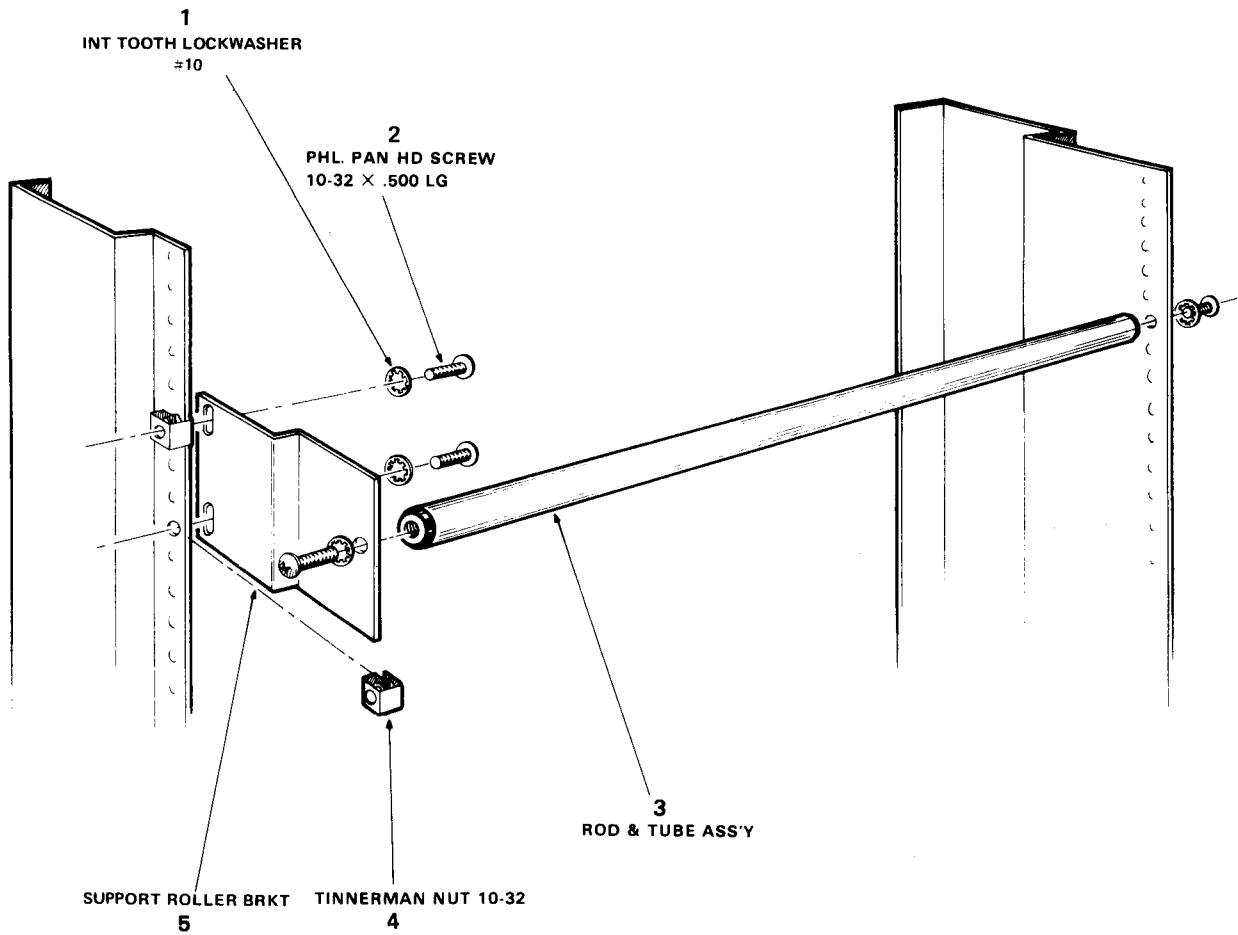

UNIT HOLE LOCATION

PRIM. LOC.	SEC. LOC.	LRV	LRC	LFV	MRV	MFV	RRV	RRC	RFV
1				42		41			
						43			
	2			69		68			
						70			

REFER TO FIGURE A-1

5	SUPPORT ROLLER	C-MD-7415654-0-0	1
4	TINNERMAN NUT	9007786	2
3	ROD & TUBE ASSY	1212173	1
2	PHL PAN HD SCREW	9006073-01	4
1	INT TOOTH LCK WASHER	9006636	4
ITEM	DESCRIPTION	DWG PART NO	QTY

MK-0354

Figure A-22 Roll Bar

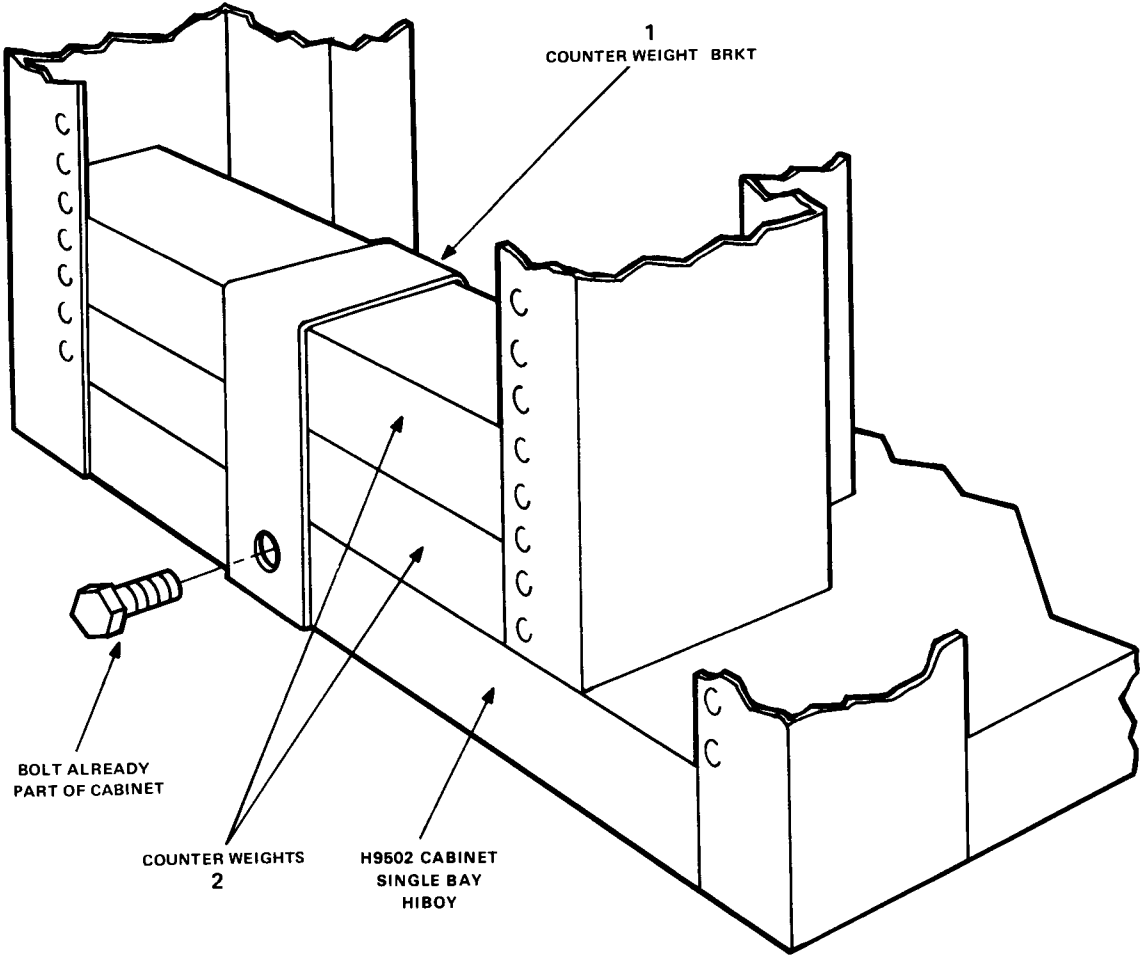

2	COUNTERWEIGHT	1211442-0	A/R	
1	BRKT, COUNTERWEIGHT	C-MD-7417608-02	A/R	2-WEIGHTS
1	BRKT, COUNTERWEIGHT	C-MD-7417608-01	A/R	1-WEIGHT
1	BRKT, COUNTERWEIGHT	C-MD-7417608-00	A/R	3-WEIGHTS
ITEM	DESCRIPTION	DWG/PART NO.	QTY	USED WITH

MA-0406

Figure A-23 Counterweight Bracket for H9602 Cabinet

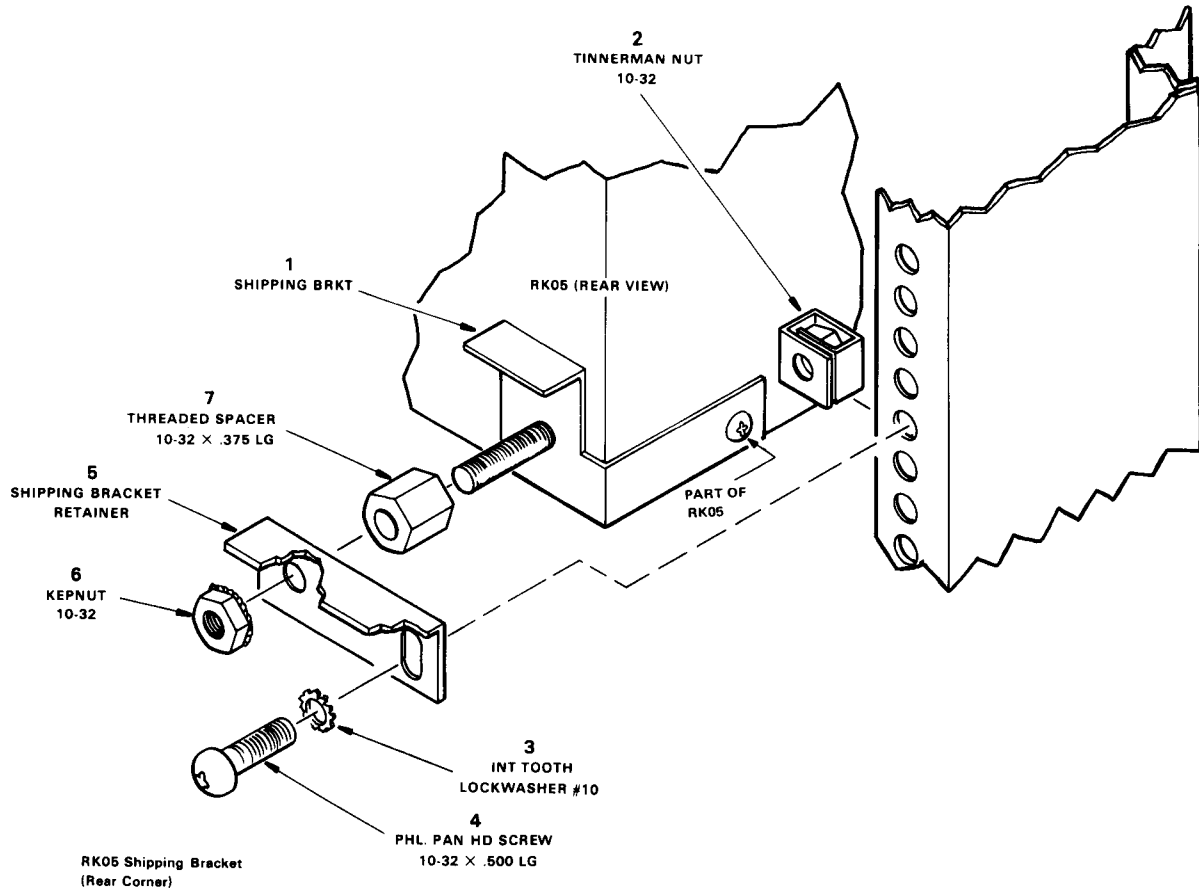

ITEM	DESCRIPTION	DWG PART NO	QTY
7	THREADED SPACER	9008436	1
6	KEPNUT	9006565	1
5	SHIPPING BRKT RET.	C-MD-7419938-0-0	1
4	PHL PAN HD SCREW	9008073-01	1
3	INT TOOTH LCK WASHER	9006636	1
2	TINNEMAN NUT	9007786	1
1	SHIPPING BRKT	C-MD-7419937-0-0	1

UNIT HOLE LOCATION

PRIM. LOC.	SEC. LOC.	LRV	LRC	LFV	MRV	MFV	RRV	RRC	RFV
1		48		48	48	48			
		50		50	50	50			
		51		51	51	51			
	2	75		75	75	75			
		77		77	77	77			
		78		78	78	78			

REFER TO FIGURE A-1

MK-0339

Figure A-24 Shipping Bracket for RK05 Disk Drive

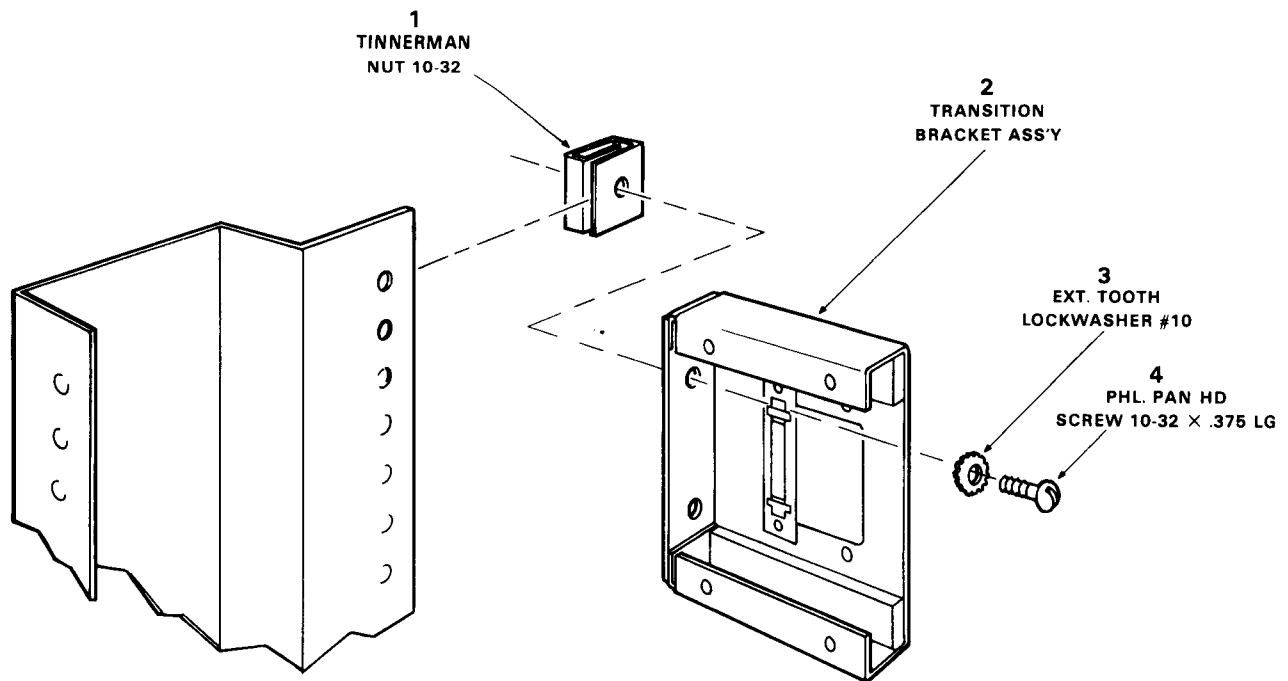

UNIT HOLE LOCATION

PRIM. LOC.	SEC. LOC.	LRV	LRC	LFV	MRV	MFV	RRV	RRC	RFV
1							63		
							69		

REFER TO FIGURE A-1

4	PHL. PAN HD SCREW	9006071-01	2
3	EXT. TOOTH LOCKWASHER	9007661	2
2	TRANSITION BRACKET ASS'Y	C-AD-7012415-0-0	1
1	TINNERMAN NUT	9007786	2
ITEM	DESCRIPTION	DWG PART NO.	QTY

MK-0337

Figure A-25 Transition Bracket (Used with RK06)

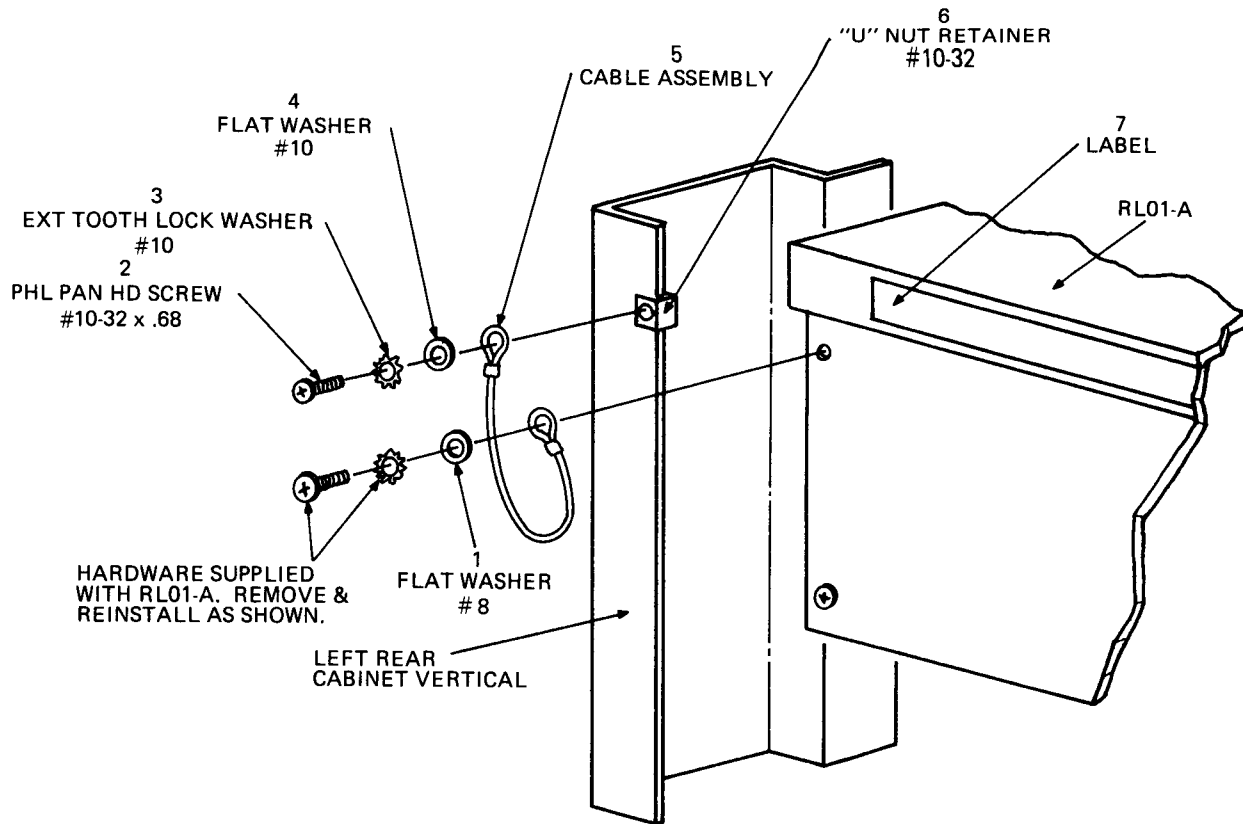

7	LABEL	3615745-00	1
6	U NUT RETAINER	9007786-00	1
5	CABLE ASSEMBLY	1215700-00	1
4	FLAT WASHER	9006664-00	1
3	EXT. TOOTH LOCK WASHER	9007651-00	1
2	PHL. PAN HD. SCREW	9008909-01	1
1	FLAT WASHER	9006662-00	1
ITEM	DESCRIPTION	DWG PART NO	QTY

NOTE:
THIS SAFETY STRAP IS USED
WHEN THE RL01 IS NOT INTER-
LOCKED. REMOVE THE STRAP
WHEN SERVICING THE RL01.

MK-0346

Figure A-26 Safety Strap for Single RL01

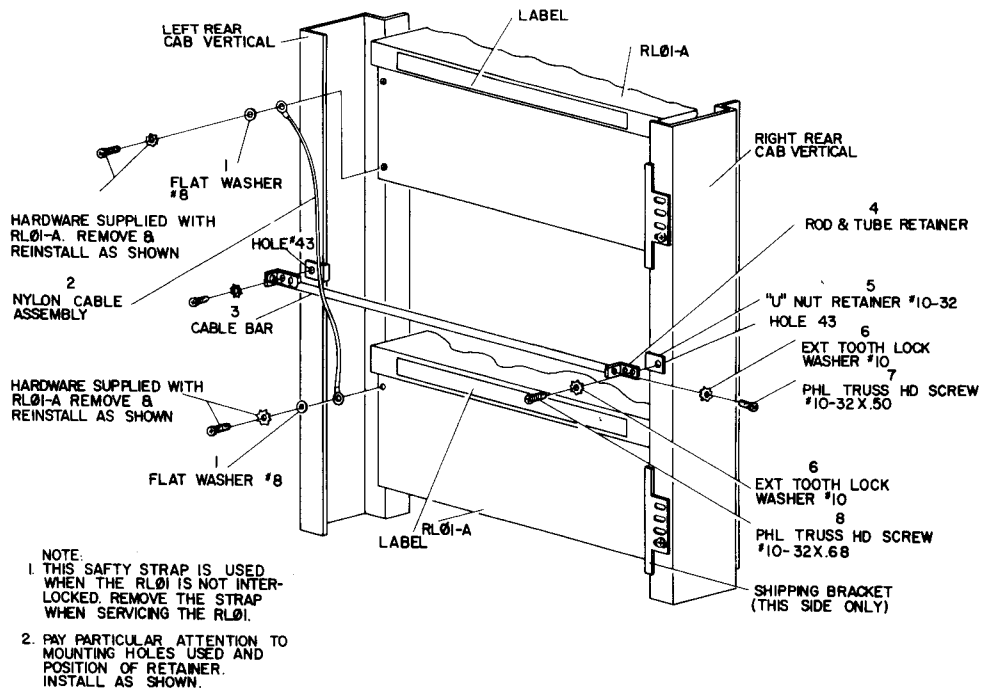

8	PHL TRUSS HD SCREW	9008008-03	2
7	PHL TRUSS HD SCREW	9006073-03	2
6	EXT TOOTH LOCKWASHER	9007651-00	4
5	U NUT RETAINER	9007786-00	2
4	ROD & TUBE RETAINER	7421503-00	2
3	CABLE BAR	1212173-00	1
2	NYLON CABLE ASSEMBLY	1215700-01	1
1	FLAT WASHER	9006662-00	2
ITEM	DESCRIPTION	DWG. PART NO.	QTY.

MK-0615

Figure A-27 Safety Strap for Dual RL01's

Reader's Comments

DEC DATASYSTEM INSTALLATION MANUAL
EK-DASYS-IN-003

Your comments and suggestions will help us in our continuous effort to improve the quality and usefulness of our publications.

What is your general reaction to this manual? In your judgment is it complete, accurate, well organized, well written, etc.? Is it easy to use? _____

What features are most useful? _____

What faults or errors have you found in the manual? _____

Does this manual satisfy the need you think it was intended to satisfy? _____

Does it satisfy *your* needs? _____ Why? _____

Please send me the current copy of the *Technical Documentation Catalog*, which contains information on the remainder of DIGITAL's technical documentation.

Name _____ Street _____

Title _____ City _____

Company _____ State/Country _____

Department _____ Zip _____

Additional copies of this document are available from:

Digital Equipment Corporation
444 Whitney Street
Northboro, Ma 01532
Attention: Communications Services (NR2/M15)
Customer Services Section

Order No. EK-DASYS-IN-003

Fold Here

Do Not Tear - Fold Here and Staple

**FIRST CLASS
PERMIT NO. 33
MAYNARD, MASS.**

**BUSINESS REPLY MAIL
NO POSTAGE STAMP NECESSARY IF MAILED IN THE UNITED STATES**

Postage will be paid by:

**Digital Equipment Corporation
Technical Documentation Department
Merrimack, New Hampshire 03054**

