

NOTES

RL01/RL02
POCKET SERVICE GUIDE

1st Edition, September 1979
(Revision) June 1980
(2nd Revision) October 1980

NOTES

Copyright © 1979, 1980 by Digital Equipment Corporation

The material in this manual is for informational purposes and is subject to change without notice.

Digital Equipment Corporation assumes no responsibility for any errors which may appear in this manual.

Printed in U.S.A.

The following are trademarks of Digital Equipment Corporation, Maynard, Massachusetts:

DEC	DECUS	DECnet
DECsystem-10	DECSYSTEM-20	DECwriter
DIBOL	Digital Logo	EduSystem
IAS	LSI-11	MASSBUS
OMNIBUS	PDP	PDT
Q-BUS	RSTS	RSX
UNIBUS	VAX	VMS
	VT	

CONTENTS

1	INTRODUCTION	1
1.1	Description	1
1.2	Option Descriptions	3
1.3	Sector Format	4
1.4	Bad Sector File	4
2	FIELD REPLACEABLE UNITS	7
3	FRONT PANEL	21
4	DRIVE CONDITIONS	23
5	REGISTER SUMMARY	25
5.1	RL11/RLV11 Register Summary	25
5.2	RL8-A Register Summary	32
6	BOOTSTRAPS	41
6.1	RL11/RLV11 Bootstrap	41
6.2	RL8-A Bootstrap	41
7	TOGGLE-IN PROGRAMS	43
7.1	Head Selection Program for RL11/RLV11	43
7.2	Head Selection Program for RL8-A	44
7.3	Get Status (With or Without Reset) on an RL11/RLV11 Subsystem	44
7.4	Get Status on an RL8-A Subsystem	45
7.5	Oscillating Seek for RL11/RLV11	46
7.6	Oscillating Seek for RL8-A	47

8	DIAGNOSTICS	49
8.1	RL11 Diagnostics	49
8.2	RLV11 Diagnostics	50
8.3	RL8-A Diagnostics	50
8.4	Diagnostic Supervisor	50
8.4.1	Hardcore Questions	50
8.4.2	Console Controls	53
8.4.3	Hardware Questions	53
8.4.4	Software Question	53
9	CHECKS, ADJUSTMENTS AND ALIGNMENTS	55
9.1	Introduction	55
9.2	Voltage Checks	56
9.3	Sector Transducer Output Check	57
9.4	Sector Pulse Timing Check	58
9.5	Positioner Radial Alignment	58
9.6	Head Alignment	63
9.7	Read Signal Amplitude Check	68
9.8	Spindle Runout Check	69
9.9	Position Signal Gain Check	71
9.10	Tachometer AC Noise Pick-Up Check	72
9.11	Velocity Profile Check	74
9.12	Servo Drive Motor Current Check	75
9.13	Access Time Check	76
10	SERVICE TIPS	81
10.1	Loss of +5V Symptom	81
10.2	Loss of +5V Causes	81
10.3	Heads Retract Immediately After Loading	81
10.4	LOAD, READY, and FAULT Indicators All On	81
10.5	RL11 I/O Cabling	81
10.6	Early RL11/RLV11 Vector Assignment	81
10.7	Role of Checks, Adjustments and Alignments in Troubleshooting	82
10.8	Intermittent Read Check Errors	82

FIGURES

1-1	Sector Format	5
1-2	Bad Sector File	6
2-1	Interconnection of FRUs	9
2-2	Signal and Function Diagram of Power Panel, AC Servo, Brush Drive Assembly	10
2-3	Signal and Function Diagram of DC Servo, Positioner	11
2-4	Signal and Function Diagram of R/W Module, R/W Heads	12
2-5	Signal and Function Diagram of Front Panel ...	13
2-6	Signal and Function Diagram of Drive Logic Module	14
2-7	Physical Location of FRUs	15
2-8	Rear View	15
2-9	Drive Logic Module Layout	17
2-10	R/W Module Layout — Top View	18
2-11	Power Panel Layout — Front View	18
2-12	DC Servo Module Layout — Bottom View .	19
2-13	AC Servo Module Layout — Front View ...	20
2-14	Front Panel Layout — Rear View	20
9-1	Sector Transducer Output	57
9-2	Sector Pulse Timing	59
9-3	Positioner and Read/Write Module Box Assembly	60
9-4	Servo Bursts and Sector Pulse	61
9-5	Positioner Assembly	62
9-6	Adjusting the Head Cables	67
9-7	Position Signal	70
9-8	Position Signal Gain Check Waveform ...	72
9-9	Summing Amplifier Output	73
9-10	Tachometer Output Velocity Signal	75
9-11	Positioner Motor Current Check	76
9-12	Access Time Check (One Track Seek)	77
9-13	Access Time Check (85 or 170 Track Seek) .	78
9-14	Access Time Check (255 or 511 Track Seek)	79

TABLES

1-1	Voltage Ranges	2
2-1	FRU Part Numbers and Interchangeability	7
2-2	Cables	8
2-3	Test Points — Drive Logic Module	
	54-12175 (Version 1)	16
2-4	Test Points — Drive Logic Module	
	54-13531 (Version 2)	16
2-5	Test Points — Drive Logic Module	
	54-14025 (Version 3)	16
4-1	Drive Conditions	23
5-1	Controller Addressable Registers	25
5-2	RL8-A Instruction Set	32
8-1	RL11/RL01 Diagnostics	49
8-2	RL11/RL02 Diagnostics	49
8-3	RL8-A/RL01 Diagnostics	50
8-4	RL8-A/RL02 Diagnostics	50
9-1	Service Jumpers for Drive Logic Module	55
9-2	Methods for Selecting Heads	56

10.7 ROLE OF CHECKS, ADJUSTMENTS AND ALIGNMENTS IN TROUBLESHOOTING

A prerequisite to module swapping as a troubleshooting procedure is to perform one or more of the checks, adjustments and alignments described in Chapter 9.

Example 1: Header Not Found and Seek Timeout errors

Typical action taken: All modules replaced; head alignment checked—problem not solved.

Solution: Radial alignment is off due to excessive head skew. This can be determined and corrected by the Positioner Radial Alignment procedure (Paragraph 9.5).

Example 2: Write Gate errors

Typical action taken: All modules replaced; head alignment checked; radial alignment checked—problem not solved.

Solution: Excessive spindle runout requires replacement of spindle. This can be determined by the Spindle Runout Check (Paragraph 9.8).

Many other problems can be solved by the checks and adjustments described in Chapter 9.

10.8 INTERMITTENT READ CHECK ERRORS

There is a new head cable guide designed to reduce the number of intermittent read check errors. See Paragraph II/2.7.1 of the *RL01/RL02 Technical Manual*.

CHAPTER 1
INTRODUCTION

CHAPTER 2
FIELD REPLACEABLE UNITS

CHAPTER 3
FRONT PANEL

CHAPTER 4
DRIVE CONDITIONS

CHAPTER 5
REGISTER SUMMARY

CHAPTER 6
BOOTSTRAPS

CHAPTER 7
PROGRAMMING EXAMPLES

CHAPTER 8
DIAGNOSTICS

CHAPTER 9
CHECKS, ADJUSTMENTS AND
ALIGNMENTS

CHAPTER 10
SERVICE TIPS

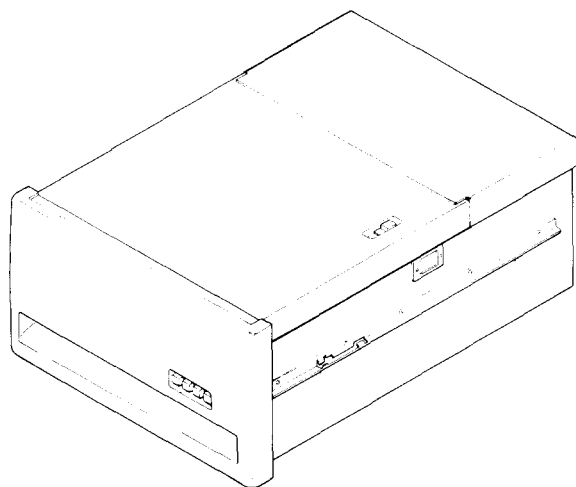

RL01/RL02 Disk Drive

The following RL01/RL02 documents are in the microfiche library.

Name	Number
RL01/RL02 Disk Drive Technical Manual	EP-RL012-TM
RL11 Controller Technical Description Manual	EP-0RL11-TD
RLV11 Controller Technical Manual	EP-RLV11-TD
RL8A Omnibus Controller Technical Manual	EP-0RL8A-TM
RL01 Disk Drive Illustrated Parts Breakdown	EP-00016-IP
RL02 Disk Drive Illustrated Parts Breakdown	EP-00016-IP
RL01/RL02 Preventive Maintenance Procedures	EP-00008-PM

CHAPTER 10 SERVICE TIPS

10.1 LOSS OF +5V SYMPTOM

If the unit does not function and the WRITE PROTECT lamp is dim, check the +5V.

10.2 LOSS OF +5V CAUSES

If the +5V is missing but the +8V is present the following causes should be checked (in addition to a defective regulator).

1. Pico fuse on DC Servo Module.
2. Thermal switch on DC Servo Module heat sink.
3. +5V overvoltage crowbar.
4. Home switch on positioner not closed.

10.3 HEADS RETRACT IMMEDIATELY AFTER LOADING

If the heads retract immediately after loading, the head cables may be reversed. Also, the positioner radial alignment may be off. (Positioner radial alignment is described in Paragraph 9.5.)

10.4 LOAD, READY, AND FAULT INDICATORS ALL ON

If those three indicators are all on, check the cabling from the controller. See Paragraph 10.5.

10.5 RL11 I/O CABLING

On RL11 systems it is fairly easy to have the I/O cabling reversed because of early documentation errors. The correct method is to have the BC06R red stripe toward the top of the M7762, the BC06R red stripe up at the transition connector, and the BC20J cable pointing down at the transition connector.

10.6 EARLY RL11/RLV11 VECTOR ASSIGNMENT

Early RL11/RLV11 Controllers were shipped with a vector address of 330 instead of 160.

CHAPTER 1

INTRODUCTION

1.1 DESCRIPTION

An RL01/RL02 Disk Subsystem consists of one to four RL01 or RL02 Disk Drives, daisy-chained via an I/O drive bus cable to one of three controllers. The controller may be an RL11, RLV11 or an RL8-A, depending upon the processor. The RL02 (using an RL02K-DC Cartridge) is the double density version of the RL01 (which uses an RL01K-DC Cartridge). Below is a list of subsystem characteristics.

- Single platter, top-loading disk cartridge similar to the 5440 type (physically but not functionally)
- The RL01K-DC and RL02K-DC cartridges are not functionally interchangeable but are physically interchangeable.
- RL01K-DC=5.2 megabytes (formatted), RL02K-DC=10.4 megabytes
- RL01K-DC=256 cylinders, RL02K-DC=512 cylinders
- RL01K-DC=125 tracks/inch, RL02K-DC=250 tracks/inch
- Both platter surfaces are used for data (upper=0, lower=1)
- 40 sectors per track — hub notched for sector marks, no index notch
- 256 eight bit bytes per sector (128 16-bit words or 170 12-bit words)
- Platter rotates at 2400 r/min — 25 ms/rev
- 3725 bits/in — 147 bits/mm max bit density
- 244 ns cell time — 4.1 megabits/sec
- MFM (Miller coding) recording technique
- Peak transfer rate=3.9 μ s/16-bit word, 1.9 μ s/8-bit byte, 2.9 μ s/12-bit word
- Average transfer rate=4.9 μ s/16-bit word, 2.4 μ s/8-bit byte, 3.7 μ s/12-bit word
- Positioner control=track-following servo information imbedded in data track during sector pulse time (servo information is read with data R/W head)
- Positioner type=D.C. servo motor with capstan/cable drive and tachometer feedback
- Factory-formatted servo and header information cannot be reformatted in the field

- Seek to next cylinder = 17 ms (max)
- Seek to next surface (switch heads) = 15 ms (max)
- Above two operations combined = 17 ms (max)
- Maximum seek = 100 ms
- Average seek = 55 ms
- Average rotational latency = 12.5 ms
- No hardware (implicit) seek
- No hardware spiral (mid-transfer) seek
- Seeks can be overlapped but subsystem gives no end of seek interrupt
- Sectors are staggered to optimize software spiral seeks
- Automatic detection of inner, outer guard bands (unique servo patterns)
- Brush cycle on cartridge spin-up
- Two separate air systems with heat exchanger
 - 1) Open-air cooling system for modules with muffin fan and coarse filter
 - 2) Closed-loop (recirculated) clean air system for cartridge using blower on spindle drive motor and absolute filter
- Spindle is belt driven from spindle drive/blower motor
- Spindle speed feedback/correction loop compensates for speed variations and allows for ac power frequency range of 50-60 Hz \pm 5%
- Two reversible connectors allow for four ranges of ac power voltage (see Table 1-1)

Table 1-1 Voltage Ranges

Range	110/220 Connector	LOW/NOM Connector
90-105	110	LOW
100-128	110	NOM
180-210	220	LOW
200-256	220	NOM

- No change for 50-60 Hz
- RL11 Controller for PDP-11 UNIBUS
 - M7762 hex-height SPC module
 - 16-bit word format
 - Normal address = 774400
 - Normal vector = 160
 - Normal interrupt level = BR5
 - Can handle RL01s and/or RL02s — can mix
 - Can handle up to four drives, and a total of 100 feet of daisy-chain drive bus

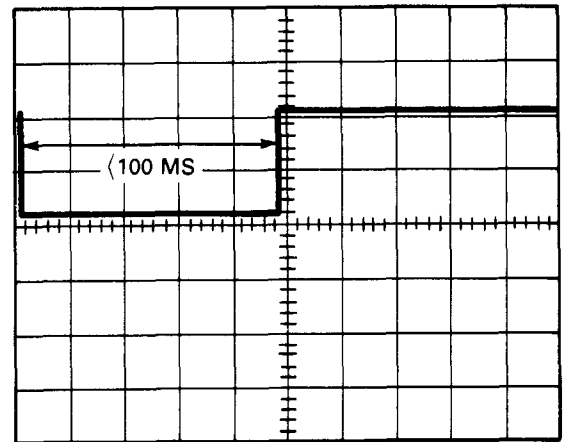

TIME = 20 MS/DIV

VOLTS = 2 V/DIV

CZ-2065

Figure 9-14 Access Time Check (255 or 511 Track Seek)

9. Measure the time the "Ready to Read/Write" signal is low. It should be less than or equal to 17 milliseconds.
10. Issue a seek from track 0 to track 85 (RL01) or track 170 (RL02) and check to see that "Ready to Read/Write" is low for slightly less than 55 milliseconds. See Figure 9-13.

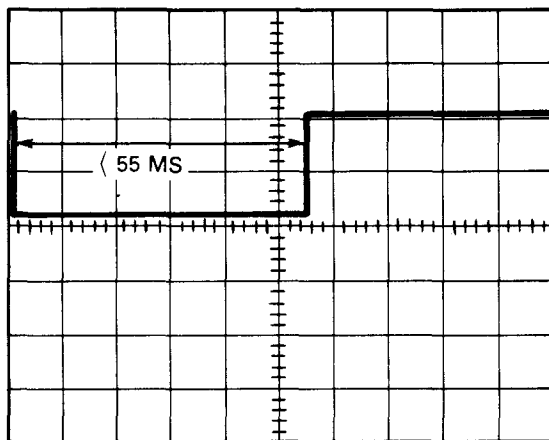

TIME=10MS/DIV

CZ-2064

VOLTS=2V/DIV

Figure 9-13 Access Time Check (85 or 170 Track Seek)

11. Issue a seek from track 0 to track 255 (RL01) or track 511 (RL02) and check to see that "Ready to Read/Write" is low for slightly less than 100 milliseconds. See Figure 9-14.
12. If the specifications are not met, the DLM, DC Servo module or the positioner itself could be at fault. (See Paragraph 9.11.)

- RLV11 Controller for LSI-11 Q-Bus
M8013 and M8014 quad height modules
16-bit word format
Normal address=174400
Normal vector=160
Interrupt level=standard (there is only one)
Can handle RL01s and/or RL02s — can mix
Can handle up to four drives, and a total of 100 feet of daisy-chain drive bus
- RL8-A Controller for PDP-8 OMNIBUS
M8433 hex-height module
8-bit byte or 12-bit word format — program selectable
12-bit word mode=max transfer of one sector/operation
Normal device code = 60, 61 for first controller, 62, 63 for second (if two controllers, only one can transfer data at a time)
Normal data break priority 0, can be jumpered for 1
Jumper selection of RL01 or RL02. If jumpered for RL02, controller can handle either or both — can mix
Can handle up to four drives, and a total of 100 feet of daisy-chain drive bus.

1.2 OPTION DESCRIPTIONS

- RL01A=RL01 unit, BC20J-10 I/O cable, chassis slide, mounting hardware
 RL02A=RL02 unit, BC20J-10 I/O cable, chassis slide, mounting hardware
 RL01K-DC=RL01 Data Cartridge
 RL02K-DC=RL02 Data Cartridge
 RL01-AK=RL01A, RL01K-DC
 RL02-AK=RL02A, RL02K-DC
 RL11-AK=RL01-AK, RL11, BC06R, transition connector, terminator
 RL211-AK=RL02-AK, RL11, BC06R, transition connector, terminator
 RLV11-AK=RL01-AK, RLV11, BC06R, transition connector, terminator
 RLV21-AK=RL02-AK, RLV11, BC06R, transition connector, terminator
 RL8A-AK=RL01-AK, RL8A, BC80J, terminator
 RL28A-AK=RL02-AK, RL8A, BC80J, terminator

CABLE DESCRIPTIONS

- BC06R-XX = Flat Berg to Berg. Used on RL11 and RLV11 subsystems to connect the controller module to a transition connector which converts Berg to ZIF.
- BC20J-XX = Round ZIF to ZIF I/O drive bus cable. Used to daisy chain one unit to another. Also used on RL11 and RLV11 subsystems to connect the transition connector to the first unit. Can also be ordered as 70-12122-XX.
- BC80J-XX = Round Berg to ZIF cable used on RL8-A subsystems to connect the controller module to the first unit.
- Terminator = Required on last unit of a subsystem.

1.3 SECTOR FORMAT

See Figure 1-1. Each sector consists of:

- Servo data during the sector pulse time
- Header preamble of 48 bits (47 zeroes followed by one "1" marker bit)
- First header information of 16 bits (this is the address and indicates cylinder, surface, and sector)
- Second header word of 16 zero bits
- Third header word of 16 bits of CRC
- Header postamble of 16 zero bits
- Data preamble of 48 bits (47 zeros followed by one "1" marker bit)
- Data — 2048 bits (can be considered as 256 8-bit bytes or 128 16-bit word or 170 12-bit words with 8 unused bits)
- Data CRC of 16 bits
- Data postamble of 16 zero bits
- Idle time waiting for next sector pulse. Varies but is approximately 20 microseconds

The user-writable area starts with the data preamble and ends with the data postamble. The remainder is factory writable only.

1.4 BAD SECTOR FILE

The Bad Sector File is located on the last track (last cylinder, last surface) of the cartridge. It occupies all forty sectors. The layout is illustrated in Figure 1-2.

A. Required Tools:

1. Oscilloscope with probes and ground leads
2. Toggle-in oscillating seek program shown in Chapter 7.
3. DIP clip
4. Jumper

B. Check:

1. Remove both top cover assemblies.
2. Defeat the top cover interlock (Table 9-1).
3. Install cartridge.
4. Depress LOAD switch.
5. Wait for heads to load onto the pack.
6. Using the oscillating seek program shown in Chapter 7, issue a one track seek.
- 7a. Version 1 of DLM: Place Channel A oscilloscope probe on E25 pin 12 (Ready to Read/Write).
- 7b. Version 2 of DLM: Place Channel A oscilloscope probe on TP 16 (Ready to Read/Write).
- 7c. Version 3 of DLM: Place Channel A oscilloscope probe on TP 16 (Ready to Read/Write).
8. Observe the waveform depicted in Figure 9-12.

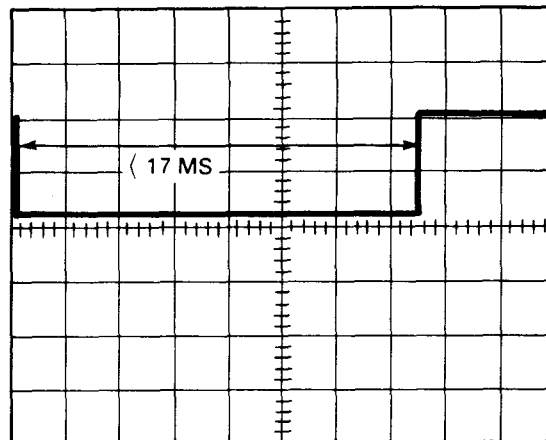

TIME=2 MS/DIV

VOLTS=2 V/DIV

CZ-2063

Figure 9-12 Access Time Check (One Track Seek)

6. Using the oscillating seek program listed in Chapter 7, cause an oscillating seek from track 0 to track 255 (RL01) or track 511 (RL02).
7. Place Channel A oscilloscope probe on TP3 of the DC Servo module.
- 8a. Version 1 of DLM: Place the external trigger on E38 pin 12 (SIGN FWD).
- 8b. Version 2 of DLM: Place the external trigger on E25 pin 12 (SIGN FWD).
- 8c. Version 3 of DLM: Place the external trigger on E25 pin 12 (SIGN FWD).
9. Observe the waveform shown in Figure 9-11.

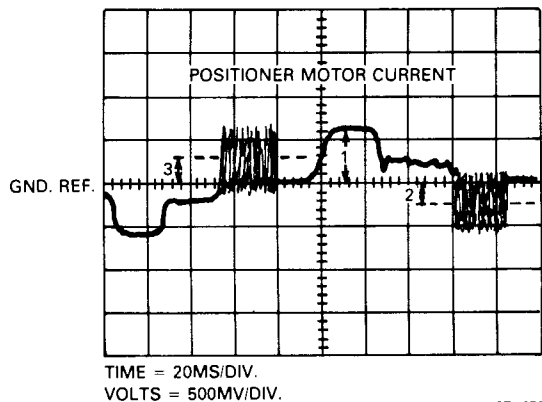

CZ-1072

Figure 9-11 Positioner Motor Current Check

10. Measure the points called out in the figure and compare them to the following:
 - # 1 should be between 750 and 780 mv.
 - # 2 and # 3 are the midpoints of the waveform and should be less than or equal to 500 mv.
11. Failure to meet specifications requires replacement of the positioner/drive motor assembly or DC Servo module (see the *RL01/RL02 Disk Drive Technical Manual*).

9.13 ACCESS TIME CHECK

The access time is checked by performing oscillating seeks and observing the “ready to read/write” signal.

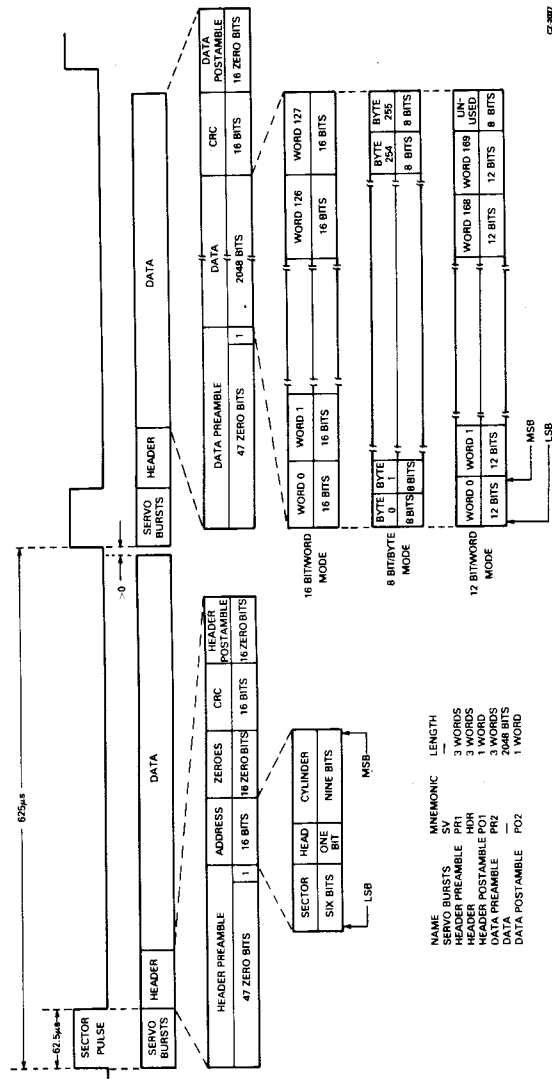

Figure 1-1 Sector Format

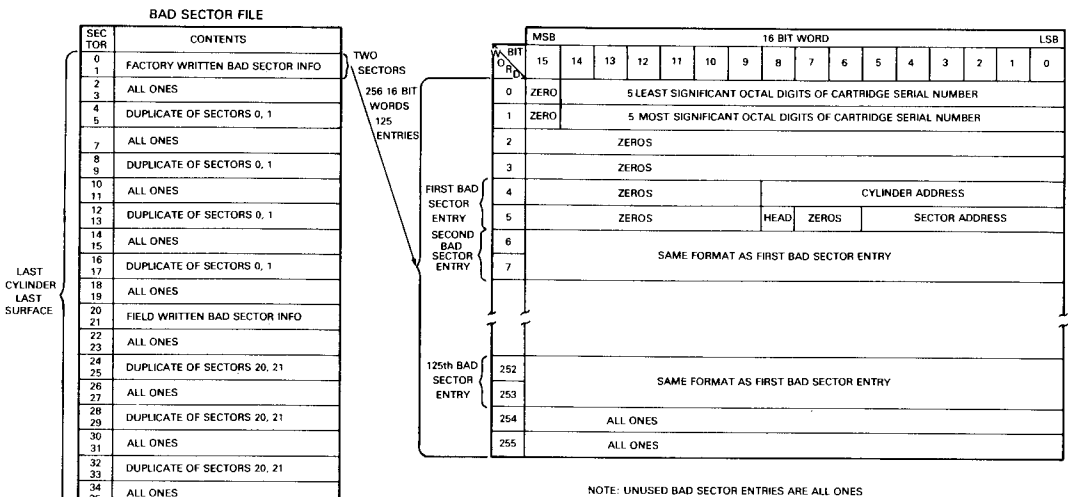

Figure 1-2 Bad Sector File

CZ-2028

9.12 SERVO DRIVE MOTOR CURRENT CHECK

One possible cause of seek errors is excessive drive motor current. This check will determine if there is too much current.

A. Required Tools:

1. Oscilloscope with probes and ground leads
2. Toggle-in oscillating seek program shown in Chapter 7
3. DIP clip
4. Jumper

B. Check:

1. Remove both top cover assemblies.
2. Defeat top cover interlock (Table 9-1).
3. Install cartridge.
4. Depress LOAD switch.
5. Wait for heads to load onto the pack.

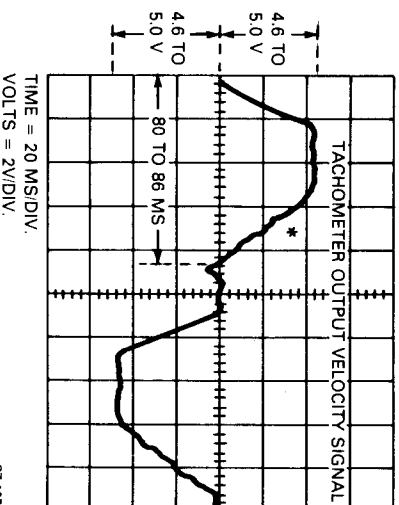

Figure 9-10 Tachometer Output Velocity Signal

CZ-1071

11. Observe the trailing edge of the waveform (as indicated by an asterisk in Figure 9-10). There should be a slight "stepping" slope. If the observed slope has spikes in it, the positioner needs replacing as it is not rolling smoothly.
12. If the other specifications (in Steps 9 and 10) cannot be met, the DC Servo module is probably at fault.

9.11 VELOCITY PROFILE CHECK

By causing the positioner to perform an oscillating seek, the velocity profile can be checked for duration, amplitude, and waveshape.

- A. Required Tools:
1. Oscilloscope with probe and ground leads
 2. Toggle-in oscillating seek program shown in Chapter 7
 3. DIP clip
 4. Jumper
- B. Check:
1. Remove both top cover assemblies.
 2. Install cartridge.
 3. Defeat top cover interlock (Table 9-1).
 4. Depress LOAD switch.
 5. Wait for heads to load onto the pack.
 6. Using the oscillating program shown in Chapter 7, cause an oscillating seek from track 0 to track 255 (RL01) or track 511 (RL02).
 - 7a. Version 1 of DLM: Place the Channel A oscilloscope probe on TP12, place the Channel A ground on any of the DLM ground points (TP1 through TP6 are ground) and place the external trigger on E38 pin 12 (SIGN FWD).
 - 7b. Version 2 of DLM: Place the Channel A oscilloscope probe on TP8, place the Channel A ground on any of the DLM ground test points (TP1 through TP4 are ground) and place the external trigger on E25 pin 12 (SIGN FWD).
 - 7c. Version 3 of DLM: Place the Channel A oscilloscope probe on TP8, place the Channel A ground on any of the DLM ground points (TP1 through TP4 are ground) and place the external trigger on E25 pin 12 (SIGN FWD).
 8. Set the oscilloscope to sync internal, positive-going, and observe the waveform shown in Figure 9-10.
 9. The peak amplitude of the waveform should be between 4.6 and 5.0 volts.
 10. The maximum seek time should be between 80 and 86 milliseconds.

CHAPTER 2 FIELD REPLACEABLE UNITS

Table 2-1 is a list of RL01/RL02 Field Replaceable Units (FRUs). Some of the FRUs contain components that are easily checked and replaced. In these cases, an FRU may be repaired instead of replaced. For example, a lamp may be replaced on the front panel or a pico fuse replaced on the DC Servo module. The decision to replace or repair an FRU should be based on such local considerations as part availability, etc.

Some of the FRUs are interchangeable between the RL01 and RL02 and some are not. The interchangeability is indicated in Table 2-1.

Table 2-1 FRU Part Numbers and Interchangeability

The following FRUs are downward-compatible only. The RL02 modules can be used on either drive with just a jumper change. The RL02 spindle can be used on either drive.

FRU	RL01 Part Number	RL02 Part Number
Read/Write Module	54-11844	54-13536
DC Servo Module	54-11850	54-13534
Template for DC Servo	74-18588	74-20826
Drive Logic Module (DLM)	54-12175	54-13531 (early) 54-14025 (later)
Spindle	70-12120	70-15116

The following FRUs are the same for both drives.

FRU	RL01/RL02 Part Number
5 amp fuse (DC Servo)	12-05747-00
AC Servo Module	54-11848
Front Panel	54-11846
Front Panel Lamp (GE 73)	12-12716-01
Sector Transducer	70-12137
Positioner	70-12117
Brush Drive Assembly	70-12112
Brush Assembly	70-16726
Spindle/Blower Motor	70-12114
Spindle Drive Belt	12-13369
Spindle Ground Brush	74-15294

FRU	RL01/RL02 Part Number
Head Cable Guide	70-16983
Insulating Sticker	74-22834
Coarse Filter	74-15297
Absolute Filter	12-13097-03
I/O Terminator	70-12293-00
Power Panel	70-12130
● Terminator Block (voltage selection)	74-16852-01A
● Circuit Breaker	12-14360-02
● Line Filter	12-12877-00
● Rectifier	11-10051-00
● Transformer	16-13897-00
● Cap, 66,000 μ F for + Vunreg	10-13530-00
● Cap, 20,000 μ F for - Vunreg	10-13531-00
● Cap, for spindle motor	10-13102-00
● Fan	12-09403-01

The following FRUs are not interchangeable between an RL01 and an RL02.

FRU	RL01 Part Number	RL02 Part Number
Upper Head	74-17178-01	70-15637-01
Lower Head	74-17178-00	70-15637-00

Table 2-2 lists the cables used in the subsystem.

Table 2-2 Cables

Cable Description	Part Number	Comments
Controller (RL11 or RLV11) to transition connector	BC06R-10	
Controller (RL8-A) to first drive	BC80J-20	
I/O drive cable	BC20J-XX	Also 70-12122-XX
Front panel to DLM	70-12107	
I/O connector to DLM	70-12123-0H	Stocked as part of 70-14262-00
AC Servo to DLM	70-12139-0M	Stocked as part of 70-14262-00
Above two cables assembled together	70-14262-00	Normally stocked
DC Servo to DLM	70-12139-0F	Signal cable
DC Servo to DLM	70-12140	Power cable
R/W to DLM	70-12139-0F	
Brush drive assy harness	70-12126	Part of Brush Drive assy

7. Disable servo drive to the carriage by disconnecting the in-line connector (Figure 9-3).
8. Set the oscilloscope (sync internally) as follows:
 - a. Channel A probe should be on TP1 of the DC Servo module (Summing Amp).
 - b. Channel A ground should be on TP11 of the DC Servo module (Signal Ground).
9. Each drive's summing amplifier output at this point will look slightly different, but it should be similar to the waveform shown in Figure 9-9.

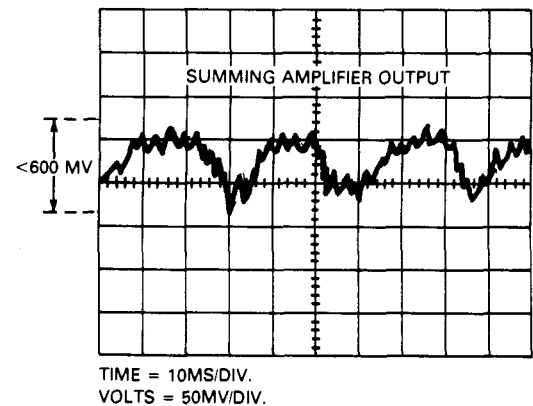

Figure 9-9 Summing Amplifier Output

10. The signal seen should have a peak-to-peak value of no more than 600 mv.
11. If the signal is out of tolerance, the DC Servo module could be bad or the drive motor may be too noisy. Replace the module, and if that does not solve the problem, replace the drive motor (see the *RL01/RL02 Disk Drive Technical Manual*).

9. Observe the waveform in Figure 9-8 while manually moving the carriage back and forth.
10. Measure the peak-to-peak deviation of the Position Signal amplitude about the ground reference. It should be 3.7 ± 0.7 volts.

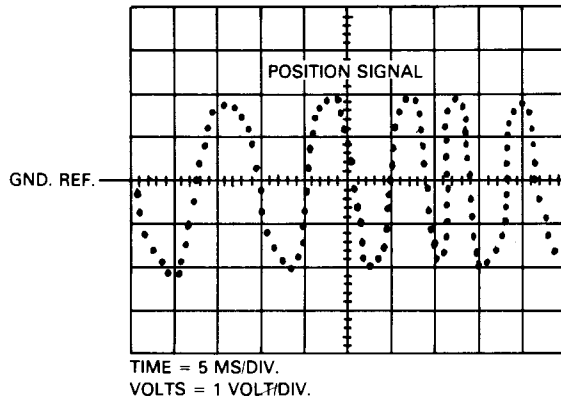

Figure 9-8 Position Signal Gain Check Waveform

9.10 TACHOMETER AC NOISE PICK-UP CHECK

This procedure checks the amount of noise being picked up by the tachometer. If the noise is excessive, the positioner will have a hard time holding on to a track signal. In this case, the READY light may flicker.

A. Required Tools:

1. Oscilloscope with probe and ground leads
2. DIP clip
3. Jumper

B. Check:

1. Remove both top cover assemblies.
2. Place the Read/Write module up and out of the way of the carriage assembly.
3. Defeat cover interlock (Table 9-1).
4. Install cartridge.
5. Depress LOAD switch.
6. Wait for heads to load onto the pack.

Table 2-2 Cables (Cont)

Cable Description	Part Number	Comments
Power panel harness	70-12108	Part of power panel
Line cord	70-12109	Part of power panel
DC Servo to power panel harness	70-12142	Part of power panel
DC Servo to positioner harness	70-12136-0	Part of positioner
Fan cable	70-12110	Part of power panel

NOTE

All cables are the same part for both the RL01 and the RL02.

Figure 2-1 illustrates the interconnection of the FRUs and shows their approximate physical positions.

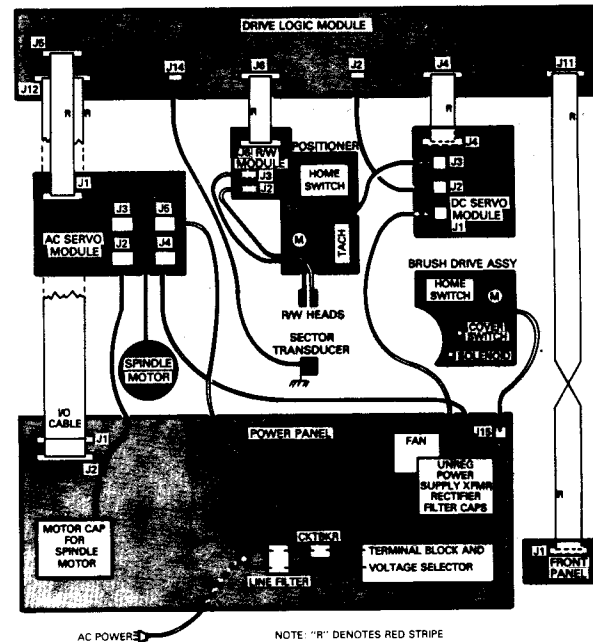

Figure 2-1 Interconnection of FRUs on RL01/RL02

Figures 2-2 thru 2-6 illustrate the functional flow and inter-connection of the FRUs.

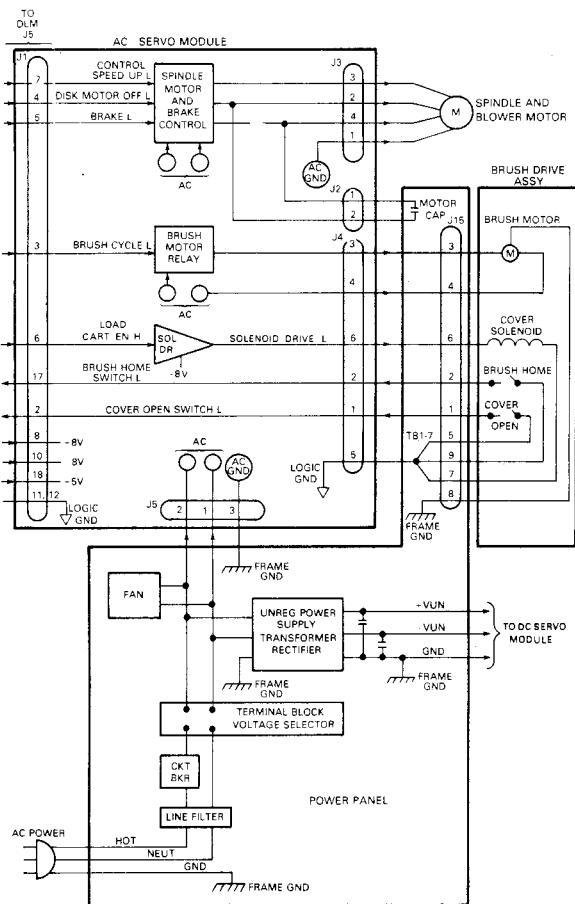

Figure 2-2 Signal and Function Diagram of Power Panel, AC Servo, Brush Drive Assembly

12. To confirm a seating problem, re-seat the cartridge and repeat the runout check. If the runout is within specification, the problem has been solved. If the runout is still out of specification, continue with Step 13.
13. Spindle and cartridge are still suspect, so install a second cartridge and repeat check. If runout is now within the specification, the first cartridge is bad. If the runout check fails once more, assume that the spindle bearings are bad and replace the spindle assembly.

9.9 POSITION SIGNAL GAIN CHECK

Insufficient amplitude of the Position Signal could result in the carriage not being able to hold itself on track, resulting in read errors and possible seek errors. Too high an amplitude could result in a jitter which, in turn, emits a vibrating-type noise from the carriage that may generate seek timeout errors.

A. Required Tools:

1. Oscilloscope with probe and ground leads
2. One DIP clip, one pin-to-pin jumper

B. Gain Check:

1. Remove both top cover assemblies.
2. Place the Read/Write module box assembly up and out of the way of the carriage assembly.
3. Defeat SKTO and cover interlock (Table 9-1).
4. Install cartridge.
5. Depress LOAD switch.
6. Wait for heads to load onto the pack.
7. Disable servo drive to the carriage by disconnecting the in-line connector (Figure 9-3).
- 8a. Version 1 of DLM: Place Channel A oscilloscope probe on E11 pin 7 (Position Signal) and place Channel A ground on TP7 (Integrator Ground).
- 8b. Version 2 of DLM: Place Channel A oscilloscope probe on TP15 (Position Signal) and place Channel A ground on TP5 (Integrator Ground).
- 8c. Version 3 of DLM: Place Channel A oscilloscope probe on TP15 (Position Signal) and place Channel A ground on TP5 (Integrator Ground).

6. Wait for heads to load onto the pack.
7. Disable servo drive to the carriage by disconnecting the in-line connector (Figure 9-3).
- 8a. Version 1 of DLM: Place Channel A oscilloscope probe on E11 pin 7 (Position Signal) and place Channel A ground on TP7 (Integrator Ground).
- 8b. Version 2 of DLM: Place Channel A oscilloscope probe on TP15 (Position Signal) and place Channel A ground on TP5 (Integrator Ground).
- 8c. Version 3 of DLM: Place Channel A oscilloscope probe on TP15 (Position Signal) and place Channel A ground on TP5 (Integrator Ground).
9. Set the oscilloscope to sync internal, negative-going, and observe the waveform in Figure 9-7.

NOTE

Ideally, the oscilloscope will display a nearly straight line of dots.

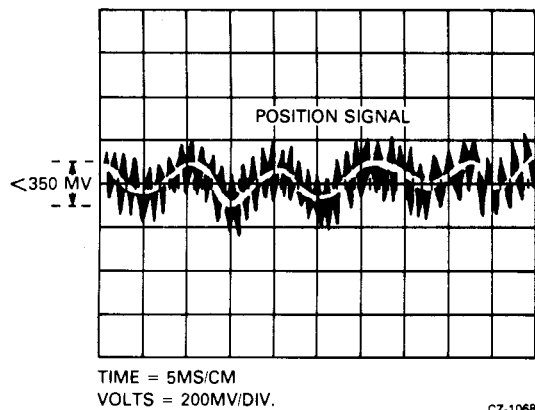

Figure 9-7 Position Signal

10. The amplitude of the runout should be no greater than 350 mv.
11. If the specification cannot be met, runout exists and another cartridge is needed to determine if the runout exists in the cartridge or the spindle.

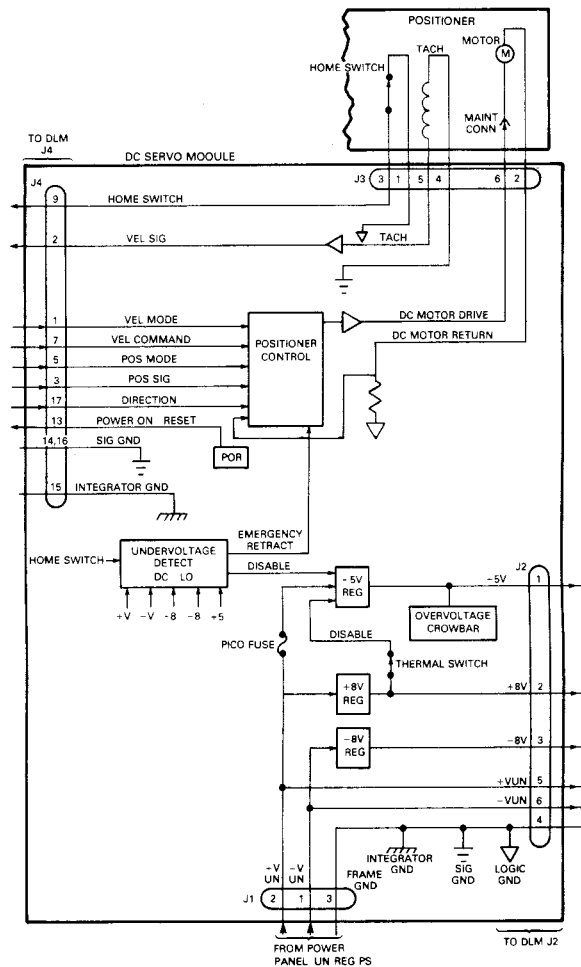

Figure 2-3 Signal and Function Diagram of DC Servo, Positioner

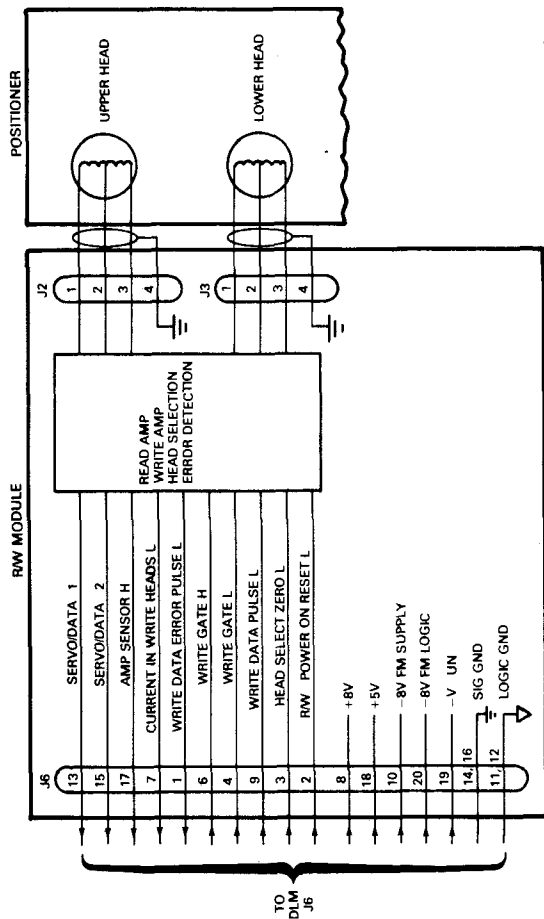

Figure 2-4 Signal and Function Diagram of RW Module, RW Heads

- 0-2-10.8
1-6.7
13. Measure and record the peak-to-peak amplitude of the S1 burst for both heads (see Table 9-2 to select heads). The minimum allowable amplitude at the innermost track is 500 mv.
 14. Reposition the carriage to track 0 by moving the positioner back until S2 disappears (outer guard band) and then forward until S2 reappears.
 15. Measure and record the peak-to-peak amplitude of S1 for both heads. The maximum allowable amplitude of the S1 burst on track 0 is 2.25 V.
 16. Replace either or both heads that do not meet the specification.

NOTE

If both heads fail to meet the specification, it is possible that the Read/Write module is bad. Replace the module (see the *RL01/RL02 Technical Manual*) and repeat the procedure. If a head is replaced, it must be aligned (see Paragraph 9.6). The radial alignment must also be checked (Paragraph 9.5).

9.8 SPINDLE RUNOUT CHECK

Excessive runout in the spindle assembly or cartridge can cause severe tracking problems for the positioning system. This check will determine whether:

1. Runout exists or does not exist
2. Runout is in the cartridge
3. Runout is in the spindle

A. Required Tools:

1. Oscilloscope with probe and ground leads
2. DIP clip
3. Jumper
4. Several test cartridges

B. Runout Check:

1. Remove both top cover assemblies.
2. Place the Read/Write module box assembly up and out of the way of the carriage assembly.
3. Defeat cover interlock (Table 9-1).
4. Install cartridge.
5. Depress LOAD switch.

9.7 READ SIGNAL AMPLITUDE CHECK

This procedure checks the amplitude of the read signal in the read amplifier.

A. Required Tools:

1. Oscilloscope with two probes
- 2a. One DIP clip, one pin-to-pin jumper and one test lead (alligator clip), or
- 2b. Two pin-to-pin jumpers and two DIP chips
3. Diagnostic listed in Table 9-2

B. Check:

1. Remove both top cover assemblies.
2. Defeat SKTO, POS SIG and the cover interlock (Table 9-1).
3. Place the Read/Write module box assembly up and out of the way on the carriage assembly.
4. Install cartridge.
5. Depress the LOAD switch.
6. Wait for the heads to load.
7. Disable the servo drive to the carriage by disconnecting the servo in-line connector.
- 8a. Version 1 of DLM: Place Channel A probe on TP9 (Sector Time).
- 8b. Version 2 of DLM: Place Channel A probe on TP11 (Sector Time).
- 8c. Version 3 of DLM: Place Channel A probe on TP11 (Sector Time).
9. Place the Channel B oscilloscope probe on TP2 of the Read/Write module (Servo Data).
10. Set the oscilloscope to sync internal on Channel A, negative-going, and observe the waveform shown in Figure 9-4.
11. Move the positioner forward until the S1 servo burst loses amplitude and finally disappears. This will be the inner guard band area of the disk.
12. Pull the positioner back slowly until the S1 servo burst returns. This will be the last data track on the disk (track 255 on an RL01, track 511 on an RL02).

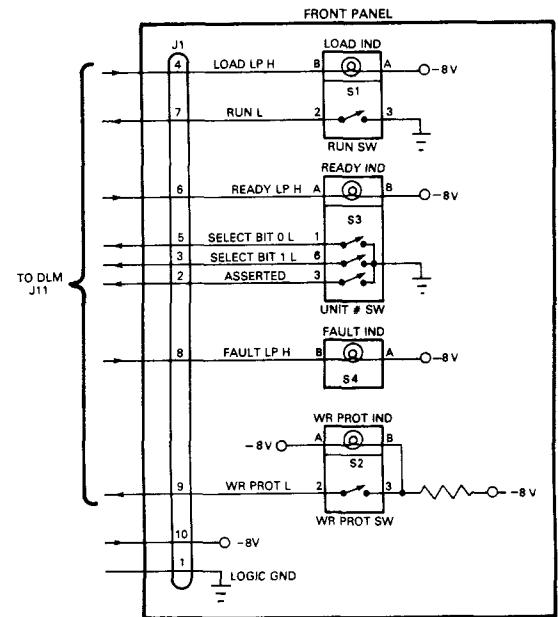

Figure 2-5 Signal and Function Diagram of Front Panel

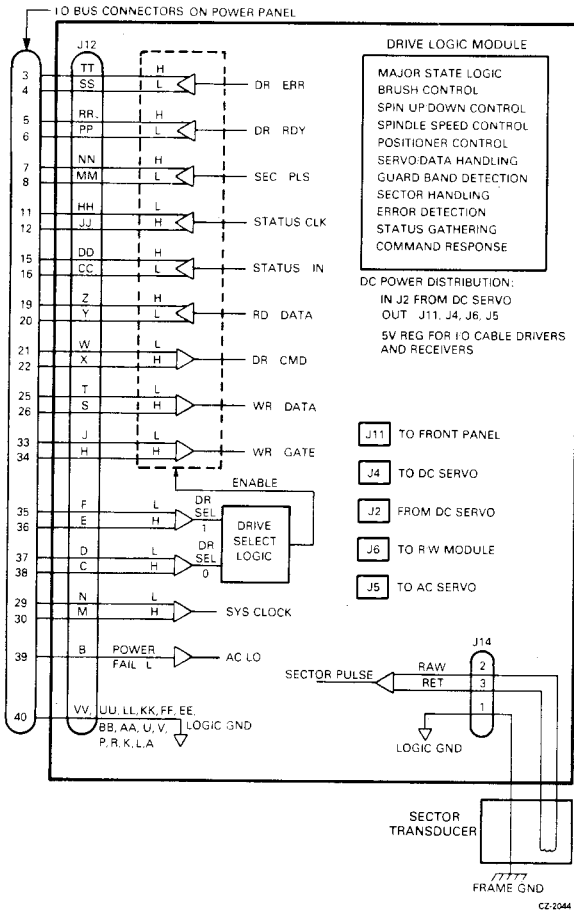

Figure 2-6 Signal and Function Diagram of Drive Logic Module

Figures 2-7 and 2-8 illustrate the physical location of the FRUs.

Figures 2-9 through 2-14 illustrate the essential component layout of the major FRUs and identify the different versions when appropriate.

13. Ensure that the cables do not touch the corner of the cable guide bracket (as shown in Figure 9-6). If they do, readjust the cables in the clips so that they do not touch the corner of the bracket.

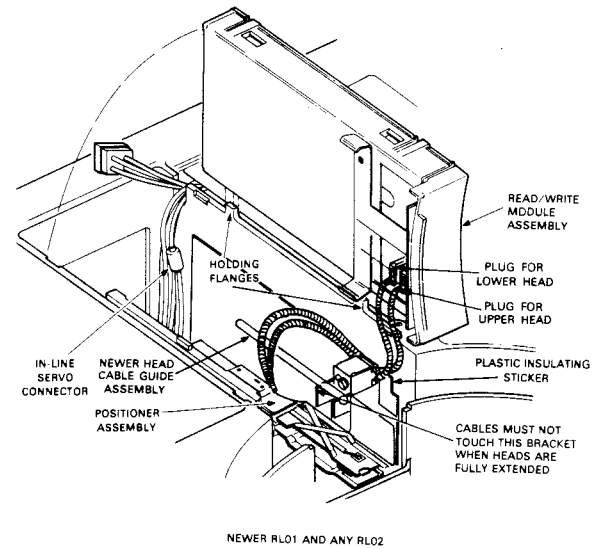

Figure 9-6 Adjusting the Head Cables

NOTE
The positioner **MUST** be fully extended when performing this check.

NOTE
The Read/Write module box assembly will have to be removed from the baseplate holding flanges and held in one hand to readjust the cables, as the cables are not long enough to reach.

14. Replace the servo in-line connector to unload the heads. At this point, the procedure is finished.

C. Head Alignment Procedure

- HD 0
IS
TOP
1. Move the positioner all the way back to the home position so that the heads are up on the ramp. Loosen the mounting screw for Head 0 and move Head 0 all the way back to its extreme position against the stop.
 2. Select Head 1.
 3. Move the positioner so that Head 1 is directly over cylinder 0.
 4. Select Head 0.
 5. Hold the positioner still while sliding Head 0 forward by twisting a screwdriver between the end of the head assembly and the stop. Observe the READY indicator and POS SIG and move Head 0 until it is over cylinder 0.
 6. Select Head 1.
 7. Verify that Head 1 is within 0.5 V of 0 V and that Head 1 is still over cylinder 0. If these two criteria are not met, repeat the procedure.
 8. Snug the mounting screw for Head 0 while the heads are over the surface. Move the positioner to its home position before tightening the mounting screw. Do not overtighten the screw.
 9. Verify that tightening the mounting screw did not change the alignment enough to make it unsatisfactory. To do this, select Head 1, move it over cylinder 0, select head 0, and verify that it, too, is over cylinder 0 and within 0.5 V. If these specifications cannot be met, repeat the procedure. Otherwise, continue with Step 10.
 10. If the head cable clips are on the Read/Write module box, replace the head cables in the clips, and go to Step 14. If the head cable clips are on the positioner, proceed with Step 11.
 11. Manually move the heads toward the spindle, as far as they will go.
 12. Mount the head cables into the clips on the cable guide. The cable for the lower head should go into the lower clip.

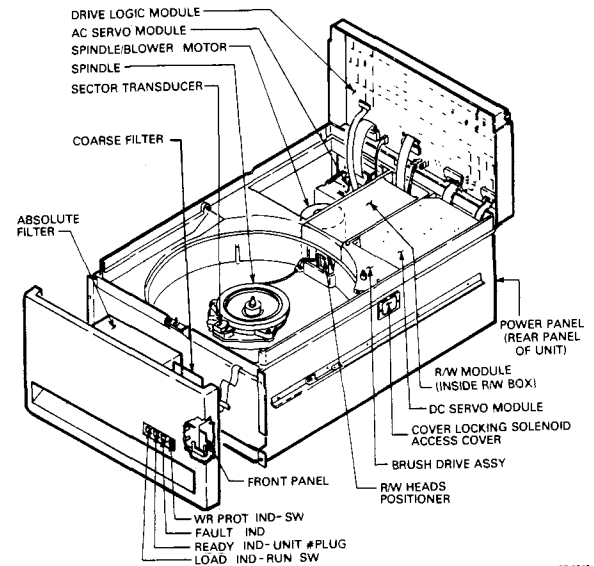

Figure 2-7 Physical Location of FRUs

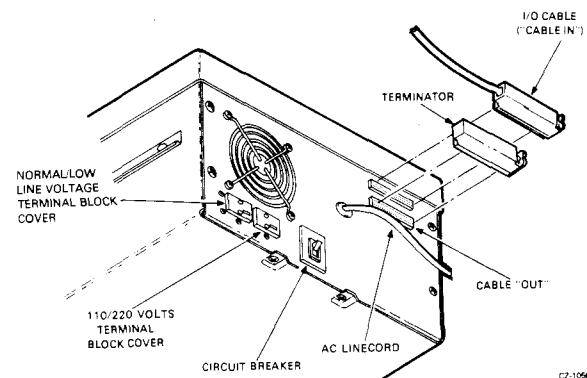

Figure 2-8 Rear View

Table 2-3 Test Points — Drive Logic Module 54-12175 (Version 1)

TP	SIGNAL	TP	SIGNAL
1	Logic Ground	9	Sector Time
2	Logic Ground	10	+8V
3	Logic Ground	11	-8V
4	Logic Ground	12	VEL SIG
5	Logic Ground	13	Signal Ground
6	Logic Ground	T1	Input to POS SIG
7	Integrator Ground	T2	E1
8	Filtered POS SIG	T3	E2

Table 2-4 Test Points — Drive Logic Module 54-13531 (Version 2)

TP	SIGNAL	TP	SIGNAL
1	Logic Ground	12	Logic Ground
2	Logic Ground	13	Borrow
3	Logic Ground	14	Raw Sector Pulse
4	Logic Ground	15	POS SIG
5	Integrator Ground	16	Ready To R/W
6	Filtered POS SIG	17	Clock Error
7	Signal Ground	18	Clock Error
8	VEL SIG	T1	Input to POS SIG
9	+8V	T2	E1
10	-8V	T3	E2
11	Sector Time		

Table 2-5 Test Points — Drive Logic Module 54-14025 (Version 3)

TP	SIGNAL	TP	SIGNAL
1	Logic Ground	16	Ready to R/W
2	Logic Ground	17	Clock Error
3	Logic Ground	18	Clock Error
4	Logic Ground	19	Cover Open
5	Integrator Ground	20	GND
6	Filtered POS SIG	21	+5V
7	Signal Ground	22	Select Head 1
8	VEL SIG	23	Seek Error
9	+8V		Timer
10	-8V	24	GND
11	Sector Time	25	GND
12	Logic Ground	26	POS SIG
13	Borrow	T1	Input to POS SIG
14	Raw Sector Pulse	T2	E1
15	POS SIG	T3	E2

NOTE

T1, T2 and T3 are pads for the formatter
 TP 17 and 18 are normally jumpered (except for mfg. checkout)

As the positioner continues to move forward, the READY indicator remains on and POS SIG is 0 V when the head is directly over the center of cylinder 0. POS SIG continues to move in the positive direction as the head passes cylinder 0 and reaches its maximum normal value of about +1.5 V as the head is halfway between cylinder 0 and cylinder 1. POS SIG then starts down as cylinder 1 is approached and is at 0 V when the head is over cylinder 1. If cylinder 1 is overshoot, POS SIG goes negative, then back to 0 V over cylinder 2, and so on.

By observing the oscilloscope and READY indicator, it is possible to locate cylinder 0 by moving the positioner into the outer guard band (POS SIG is negative and the READY indicator is off), and then moving the positioner forward to cylinder 0 (POS SIG rises to 0 V and the READY indicator turns on). The verification process is to move the positioner in reverse and observe the POS SIG go negative as the reverse and observe the POS SIG go negative as the READY indicator goes off and see the POS SIG stay negative as the head moves over the outer guard band.

11. Position Head 1 directly over cylinder 0.
12. Hold the positioner still and select Head 0.
13. If POS SIG is within 0.5 V of 0 V, then verify that Head 0 is over cylinder 0. If both of these criteria are met, the head alignment is satisfactory. Be sure to reconnect the in-line servo connector before unloading the heads. The head alignment check is complete. Go on to the next check.
14. If POS SIG was not within 0.5 V of ground or Head 0 was over a cylinder other than 0, perform the head alignment procedure (below).

NOTE

No alignment cartridge is required.

B. Alignment Check:

1. Remove both top cover assemblies.
2. Defeat SKTO, POS SIG and cover interlock (Table 9-1).

NOTE

These jumpers enable the diagnostic routine to work by disabling the Seek Timeout Error.

3. Place the Read/Write module box assembly up and out of the way of the carriage assembly.
4. Install cartridge.
5. Depress the LOAD switch.
6. Wait for the heads to load onto the pack.
7. Disable servo drive to the carriage by disconnecting the servo in-line connector (Figure 9-3).
8. Select Head 1 (Table 9-2).
9. Place oscilloscope probe A on POS SIG and connect probe A ground lead to ground. Set the vertical gain for 1 volt per division. Set oscilloscope horizontal circuit to free run (unsynched). The horizontal sweep rate is not important.

10. Manually move the positioner back to the head loading ramp and then forward toward the center of the disk while watching the READY indicator and the oscilloscope presentation of POS SIG. These two will indicate the position of the head relative to the tracks written on the disk surface.

When the head is over the head loading zone (outside the outer guard band), POS SIG floats slowly toward +8 V and the READY indicator is on. When the head is over the outer guard band, POS SIG is at maximum negative (about -1.5 V) and the READY indicator is off. As the head approaches cylinder 0, POS SIG starts to move up toward 0 V and the READY indicator turns on.

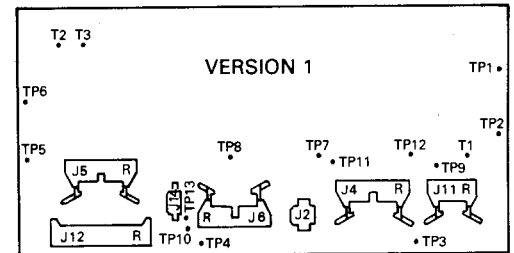

54-12175
RL01 ONLY

NOTE:
J11 AND J4
POINT DOWN

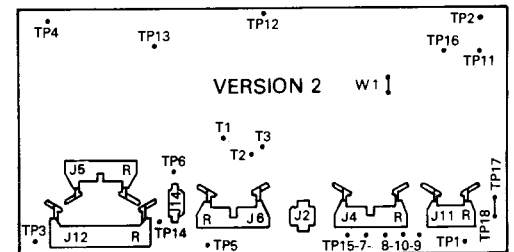
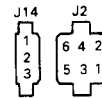

54-13531
RL02 OR RL01
W1 IN FOR RL01
W1 OUT FOR RL02

NOTE:
J4 AND J11 POINT UP
NO TP19 THRU 26

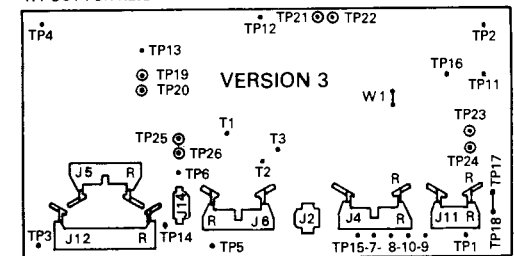

NOTE: R DENOTES RED STRIPE

54-14025
RL02 OR RL01
W1 IN FOR RL01
W1 OUT FOR RL02

NOTE:
J4 AND J11 POINT UP
HAS TP19 THRU 26

JUMPER TEST LUGS EFFECT
19-20 DEFEAT COVER CLOSED
21-22 SELECT HEAD 1
23-24 DISABLE SKTO

(THESE TEST LUGS ARE CIRCLED)

CZ-2046

Figure 2-9 Drive Logic Module Layout

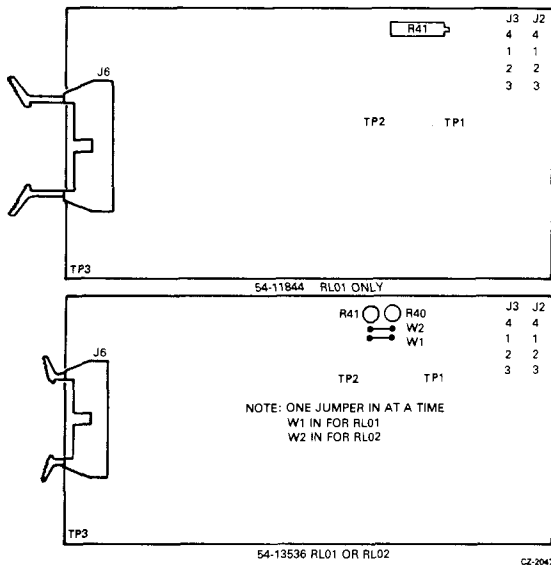

Figure 2-10 R/W Module Layout — Top View

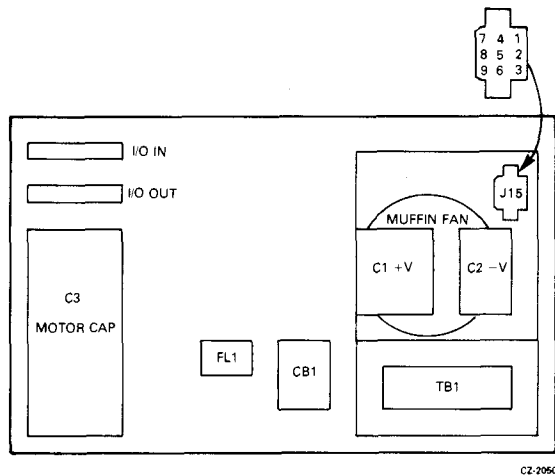

Figure 2-11 Power Panel Layout — Front View

3. Take the two flat-blade screwdrivers and insert them into the adjusting slots on the positioner.
4. Move the positioner assembly against the right hand side of the drive (toward the Read/Write module).
5. Manually move the carriage to its approximate center of travel.
6. Using the two flat-blade screwdrivers in the adjusting slots, slide the positioner baseplate until the 15 ± 3 microsecond specification between the fall of the sector pulse and the rise of the S1 servo burst can be met. (See Figure 9-4.)

NOTE

Equal pressure must be exerted on the screwdrivers when sliding the positioner to ensure that the baseplate is kept straight.

7. Tighten the six retaining screws in small increments.
8. Check the 15 ± 3 microseconds specification for Head 0 at track 0 and the last track. If the head is within the specification, the check is complete. Otherwise, repeat the adjustment (Part C) above.

9.6 HEAD ALIGNMENT

This procedure will ensure that the two heads are in line with each other to cut down on the servo tracking time when switching heads.

NOTE

The Positioner Radial Alignment (Paragraph 9.5) should be done before attempting the head alignment, so that any head skew that may be present will be detected BEFORE the head alignment.

A. Required Tools:

1. Oscilloscope with one probe
2. 3/32" Allen wrench
3. Flat-blade screwdriver
- 4a. One DIP clip, one pin-to-pin jumper and one test lead (alligator clip), or
- 4b. Two pin-to-pin jumpers and two DIP clips
5. Diagnostic listed in Table 9-2

C. Positioner Alignment

1. Using Figure 9-5 as a guide, locate the six largest Phillips screws on the positioner base-plate.
2. Loosen (but do not remove) the six screws holding down the positioner.

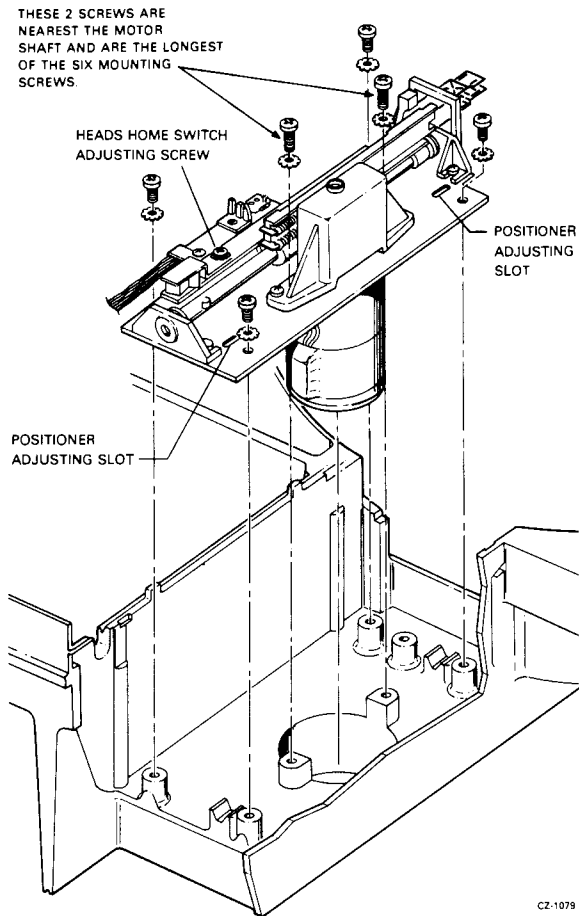

CZ-1079

Figure 9-5 Positioner Assembly

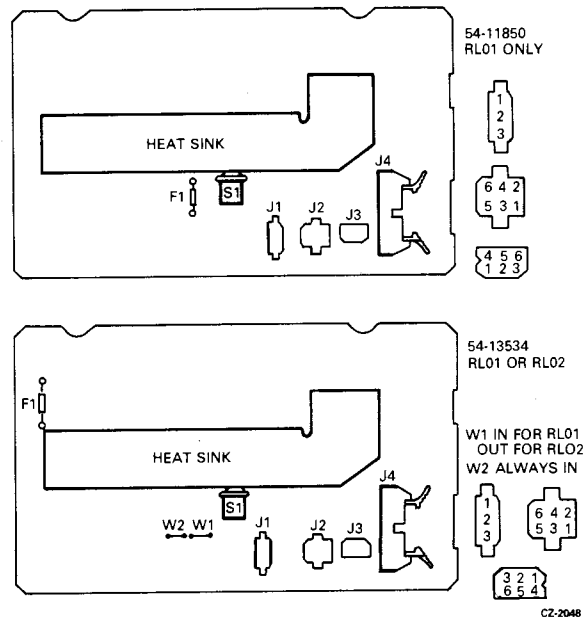
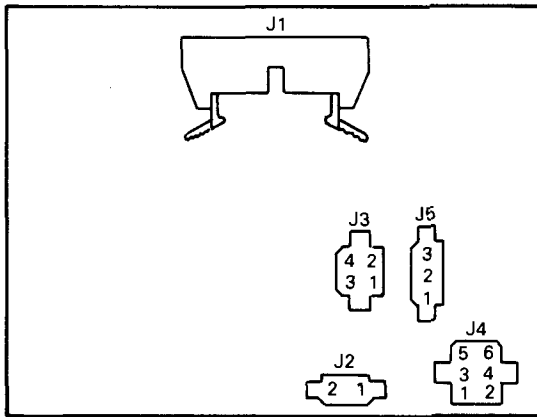

Figure 2-12 DC Servo Module Layout — Bottom View

NOTE

Later versions of the DC Servo Module have the jumpers (W1 and W2) on top of the module. Thus, they are accessible through the plastic template.



CZ-2048

Figure 2-13 AC Servo Module Layout — Front View

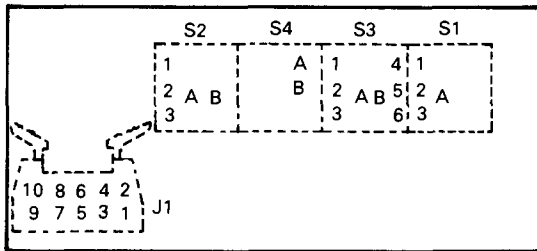

CZ-2051

Figure 2-14 Front Panel Layout — Rear View

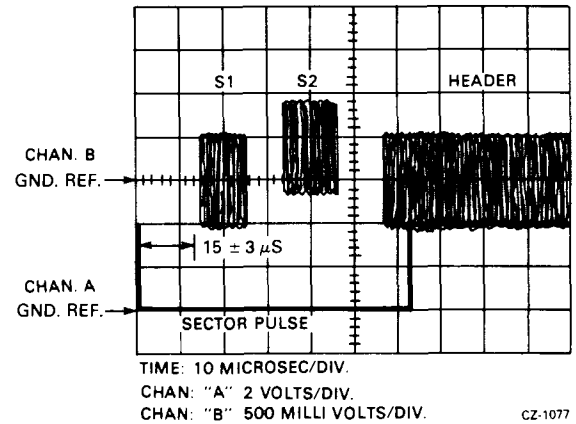

CZ-1077

Figure 9-4 Servo Bursts and Sector Pulse

12. Measure the time between the negative-going edge of the sector pulse and the beginning of the S1 servo burst when the positioner is at Cylinder 0. Record this value. $20-1$
 $18-0$
13. Select Head 0 (Table 9-2).
14. Repeat Step 12 for Head 0. Record this value.
15. If the difference between these two values is greater than six microseconds, replace Head 0 (see the *RL01/RL02 Disk Drive Technical Manual*) and go back to Step 14. If either of these two values falls outside of the 15 ± 3 microsecond specification, perform the alignment procedure (Part C) below. Otherwise, continue.
16. Manually move the carriage to the last data track (track 255 on an RL01 or track 511 on an RL02). As Head 0 enters the inner guard band, S1 disappears. Move the positioner back until S1 appears.
17. Measure the time between the negative-going edge of the sector pulse and the beginning of the S1 servo burst when the positioner is at the last cylinder. It should be 15 ± 3 microseconds. If so, the check is complete. Otherwise perform the adjustment (Part C) below.

9. Place the Channel B oscilloscope probe on TP2 of the Read/Write module (data) and Channel B ground on any signal ground (TP1 - TP4).
- 10a. Version 1 of DLM: Place Channel A probe on TP9 (SEC TIME) and Channel A ground on any signal ground (TP1-TP4).
- 10b. Version 2 of DLM: Place Channel A probe on TP11 (SEC TIME) and Channel A ground on any signal ground (TP1-TP4).
- 10c. Version 3 of DLM: Place Channel A probe on TP11 (SEC TIME) and Channel A ground on any signal ground (TP1-TP4).
11. Set the oscilloscope to sync internal, negative-going on Channel A and observe the waveform shown in Figure 9-4.

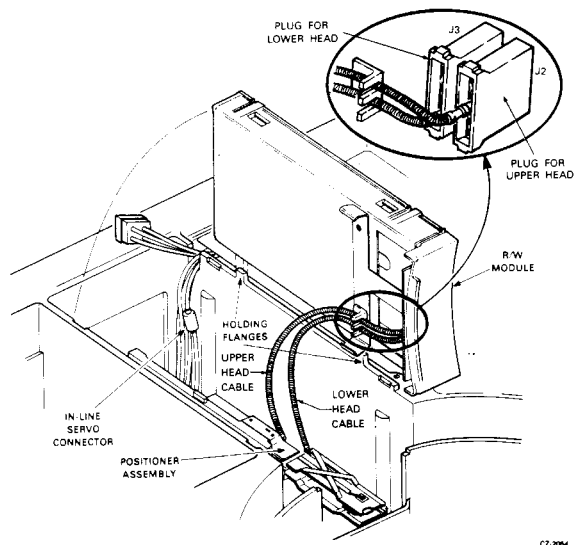

Figure 9-3 Positioner and Read/Write Module Box Assembly

NOTE

S1 and S2 servo bursts may not appear in the positive/negative proportions shown in Figure 9-4, depending upon which track the head is centered on.

CHAPTER 3 FRONT PANEL

FRONT PANEL SWITCHES AND INDICATORS

- **LOAD** indicator is on when the spindle is stopped and the cover is unlocked. This indicates that the operator can open the cover to load or unload the cartridge.
- **LOAD** switch is an alternate action switch that is used to start or stop the spindle. The **IN** position corresponds to **RUN** and the **OUT** position to **STOP**.
- **UNIT NUMBER** plug has cams on the back to encode the unit number into electrical signals. The corresponding number is stamped on the front for the operator to read. The number can be 0 through 3. The plug also serves as a **READY** indicator.
- **READY** indicator is on when the cartridge is up to speed, brush cycle finished, heads loaded, and the heads are "on track". The unit is ready to perform a Read, Write, or Seek operation.
- **FAULT** indicator is on when certain drive conditions exist. These conditions are shown in Table 4-1 — Drive Conditions.
- **WRITE PROT** indicator is on when the Write Protect condition is true. It is the result of the state of the **WRITE PROT** switch.
- **WRITE PROT** switch is an alternate action switch that establishes the Write Protect condition. The **IN** position corresponds to the Write Protect state.

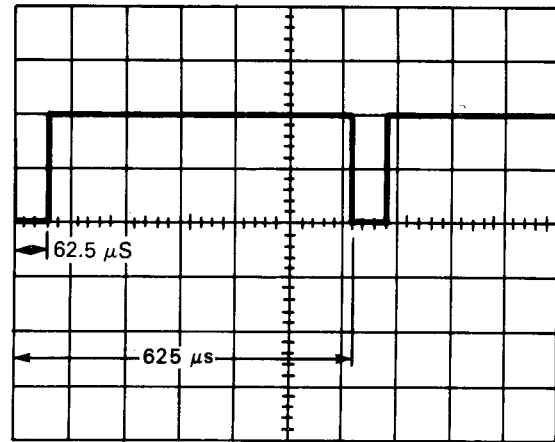

TIME = 100 μ s/DIV.

VOLTS = 2V/DIV.

CZ-1078

Figure 9-2 Sector Pulse Timing

A. Tools Required:

1. Oscilloscope with two probes
2. Two flat-blade screwdrivers
3. One Phillips head screwdriver
- 4a. One DIP clip, one pin-to-pin jumper and one test lead, or
- 4b. Two pin-to-pin jumpers and two DIP clips
5. Diagnostic listed in Table 9-2.

B. Positioner Alignment Check:

1. Remove both top cover assemblies.
2. Defeat POS SIG, SKTO and cover interlock (Table 9-1).
3. Place the Read/Write module box assembly up and out of the way of the carriage assembly.
4. Install cartridge.
5. Depress LOAD switch.
6. Wait for heads to load onto the pack.
7. Disable servo drive to the carriage by disconnecting the in-line connector (Figure 9-3).
8. Select Head 1 (Table 9-2).

NOTE

The waveform must be negative-going first.

8. If the specification cannot be met, the sector transducer must be replaced.

9.4 SECTOR PULSE TIMING CHECK

This is a check of the sector pulse width and repetition rate. The repetition rate is a function of spindle speed.

A. Required Tools:

Oscilloscope with probe.

B. Check:

1. Remove both top cover assemblies.
2. Defeat cover interlock (Table 9-1).
3. Install cartridge.
4. Depress LOAD switch.
- 5a. Version 1 of DLM: Place the probe on TP9.
- 5b. Version 2 of DLM: Place the probe on TP11.
- 5c. Version 3 of DLM: Place the probe on TP11.
6. Set the oscilloscope to sync internal, negative-going. The signal displayed on the oscilloscope should be the same as in Figure 9-2. Sector pulse width should be 62.5 microseconds. Correct disk speed ranges from 594 microseconds to 639 microseconds, with 624 being the desired norm. The sector pulses should be stable at some time period within that range.

9.5 POSITIONER RADIAL ALIGNMENT

The positioner radial alignment checks assure that the conditions listed below are true.

- The servo bursts (as read by the read/write heads) must occur during the correct time relative to the sector pulse (as detected by the sector transducer at the hub). Because the sector transducer is fixed, changing the head positioner location will affect this timing relationship.
- The servo burst/sector timing relationship must be the same at track 0 as it is at the innermost track because the head carriage moves straight toward the center of the disk.

**CHAPTER 4
DRIVE CONDITIONS****Table 4-1 Drive Conditions**

Condition	Bit*	FAULT Light	Drive Error	Heads Unld.	Comment
Device Select Error (DSE)	8	Yes	Yes	No	Set by Drive Select and SEC PLS from another unit. Cleared by Reset or Power On Reset (POR).
Volume Check (VC)	9	No	Yes	No	Set by Load Heads cycle. Cleared by Reset or POR.
Write Gate Error (WGE)	10	Yes	Yes	No	Set during Write Gate if one or more of the following occur: <ul style="list-style-type: none"> ● Drive is not "Ready to Read/Write" ● Drive is Write Protected ● Sector pulse is occurring ● Drive has another error Cleared by Reset or POR.
Spin Error (SPE)	11	Yes	Yes		Spin-up Timeout prevents loading of heads. Set by Spin-up Timeout (40 sec) or Over-speed. Cleared by Reset or POR.
Seek Timeout (SKTO)	12	Yes	Yes	No	Set by timeout of approximately 1.5 sec. Cleared by Reset or POR.

*Bit in Multipurpose Register after a Get Status command

MPR= 774406

Table 4-1 Drive Conditions (Cont)

Condition	Bit*	FAULT Light	Drive Error	Heads Unld.	Comment
Write Lock Status (WLS)	13	No	No	No	Not an error condition. Set and cleared by WRITE PROT switch.
Current In Heads Error (CHE)	14	Yes	Yes	Yes	Set by Current in Heads AND NOT Write Gate. Cleared by Reset or POR.
Write Data Error (WDE)	15	Yes	Yes	Yes	Set by Write Gate AND No Write Data Transitions. Cleared by Reset or POR.
Clock Error (---)	--	Yes	Yes	Yes	Does not latch. No status bit. Set by loss of SYS CLK from controller. Clears itself if condition corrects itself.

*Bit in Multipurpose Register after a Get Status command

9.3 SECTOR TRANSDUCER OUTPUT CHECK

This check verifies a correct output of the sector transducer.

A. Required Tools:

1. Oscilloscope with probe
2. DIP clip

B. Check:

1. Remove both top cover assemblies.
2. Install cartridge.
3. Defeat the cover interlock (Table 9-1).
4. Depress LOAD switch.
5. While waiting for the heads to load onto the pack, set up the oscilloscope (sync internal negative-going). Set vertical coupling to AC.
- 6a. Version 1 of DLM: Place oscilloscope probe on E8 pin 8.
- 6b. Version 2 of DLM: Place oscilloscope probe on TP14.
- 6c. Version 3 of DLM: Place oscilloscope probe on TP14.
7. The signal displayed on the oscilloscope should be similar to that shown in Figure 9-1. The peak output of the negative portion of the waveform should be between 0.35Vp and 1.5Vp.

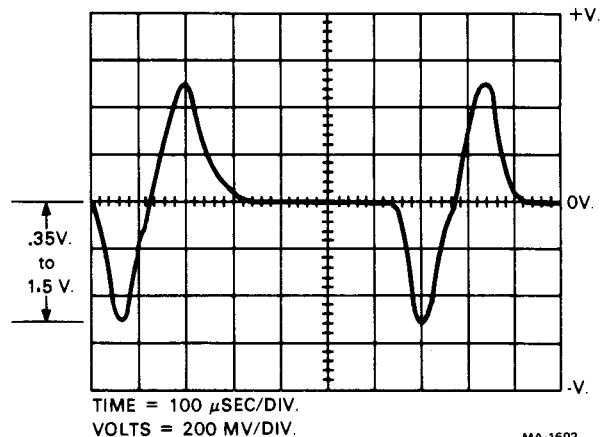

MA-1602

Figure 9-1 Sector Transducer Output

Table 9-2 Methods for Selecting Heads

For a PDP-11-based subsystem:

DLM Version 1 or 2	DLM Version 3
Load DZRLCXX or CZRLIXX and run head alignment routine. Having the WRIT PROT switch in selects Head 1; having it out selects Head 0.	Jumper TP21 to TP22 to select Head 1. Removing the jumper selects Head 0.

For a PDP-8-based subsystem:

	Same as above
Load AJRLBXX or AJRLHXX and run head alignment routine. Having the WRIT PROT switch in selects Head 1; having it out selects Head 0.	

NOTE

If diagnostics are not available, toggle in the appropriate program shown in Chapter 7.

9.2 VOLTAGE CHECKS

The DC Servo module template indicates voltage test points. Check the following voltages.

Voltage	Limits
+V _{un}	+14V to +18V
-V _{un}	-14V to -18V
+5V	+4.85V to +5.35V
+8V	+7.7V to +8.3V
-8V	-7.7V to -8.3V

The regulators on the DC Servo module are not adjustable. If a voltage is out of tolerance, the faulty FRU should be replaced.

The +5V can be killed by a blown pico fuse, a thermal switch on the DC Servo heat sink, an overvoltage crowbar, or a home switch on the positioner not closed during power up.

CHAPTER 5 REGISTER SUMMARY

5.1 RL11/RLV11 Register Summary

Table 5-1 Controller Addressable Registers

Address (octal)	Type (read/write)	Register Name/Mnemonic	Basic Function
774400	R/W	Control Status (CS)	Indicates drive ready condition; decodes drive commands and provides overall control functions and error indications
774402	R/W	Bus Address (BA)	Indicates memory location involved in data transfer during a normal read or write operation
774404	R/W	Disk Address (DA)	(1) Holds disk address during a data transfer such as Read or Write; or (2) holds the drive command word for a Seek command; or (3) holds the drive command word for a Get Status command
774406	R/W	Multi-purpose (MP)	(1) Functions as word counter when transferring read/write data between UNIBUS and drives; or (2) holds results of a Get Status command; or (3) holds results of a Read Header command.

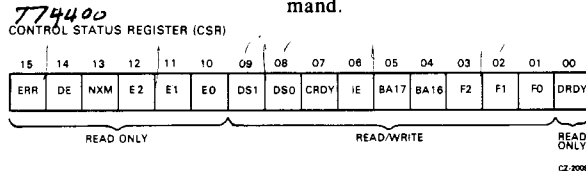

Bit(s)	Name	Function
0	Drive Ready (DRDY)	When set, this bit indicates that the selected drive is ready to receive a command. The bit is cleared when a seek operation is initiated and set when the seek operation is completed.

Bit(s)	Name	Function																																													
1-3	Function Code	<p>These bits are set by software to indicate the command to be executed.</p> <p>Command execution requires that Bit 7 (Controller Ready) be cleared by software. A zero bit being transferred into bit 7 of the CSR can be considered as a Go bit.</p> <table border="1"> <thead> <tr> <th>F2</th> <th>F1</th> <th>F0</th> <th>Command</th> <th>Octal Code</th> </tr> </thead> <tbody> <tr> <td>0</td> <td>0</td> <td>0</td> <td>No Op (RL11) or Maint. (RLV11)</td> <td>0</td> </tr> <tr> <td>0</td> <td>0</td> <td>1</td> <td>Write Check</td> <td>1</td> </tr> <tr> <td>0</td> <td>1</td> <td>0</td> <td>Get Status</td> <td>2</td> </tr> <tr> <td>0</td> <td>1</td> <td>1</td> <td>Seek</td> <td>3</td> </tr> <tr> <td>1</td> <td>0</td> <td>0</td> <td>Read Header</td> <td>4</td> </tr> <tr> <td>1</td> <td>0</td> <td>1</td> <td>Write Data</td> <td>5</td> </tr> <tr> <td>1</td> <td>1</td> <td>0</td> <td>Read Data</td> <td>6</td> </tr> <tr> <td>1</td> <td>1</td> <td>1</td> <td>Read Data Without Header Check</td> <td>7</td> </tr> </tbody> </table>	F2	F1	F0	Command	Octal Code	0	0	0	No Op (RL11) or Maint. (RLV11)	0	0	0	1	Write Check	1	0	1	0	Get Status	2	0	1	1	Seek	3	1	0	0	Read Header	4	1	0	1	Write Data	5	1	1	0	Read Data	6	1	1	1	Read Data Without Header Check	7
F2	F1	F0	Command	Octal Code																																											
0	0	0	No Op (RL11) or Maint. (RLV11)	0																																											
0	0	1	Write Check	1																																											
0	1	0	Get Status	2																																											
0	1	1	Seek	3																																											
1	0	0	Read Header	4																																											
1	0	1	Write Data	5																																											
1	1	0	Read Data	6																																											
1	1	1	Read Data Without Header Check	7																																											
4-5	Bus Address Extension Bits (BA16, BA17)	The two most significant bus address bits. Read and written as data bits 4 and 5 of the CS register but considered as address bits 16 and 17 of the bus address register.																																													
6	Interrupt Enable (IE)	When this bit is set by software, the controller is allowed to interrupt the processor at the normal command or error termination.																																													
7	Controller Ready (CRDY)	When cleared by software, this bit indicates that the command in bits 1-3 is to be executed. When set, this bit indicates the controller is ready to accept another command.																																													
8-9	Drive Select (DS0, DS1)	These bits determine which drive will communicate with the controller via the drive bus.																																													
10	Operation Incomplete (OPI)	When set, this bit indicates that the current command was not completed within 200 ms.																																													

CHAPTER 9 CHECKS, ADJUSTMENTS AND ALIGNMENTS

9.1 INTRODUCTION

Many of the checks, adjustments and alignments described in this chapter deal with the Drive Logic Module (DLM). Because there are three different versions of the DLM, it is necessary to first identify the particular type of module on the drive being serviced. The three versions are shown in Figure 2-9.

- Version 1 (Part No. 54-12175) can be identified by the fact that the two Berg connectors in the lower right hand of the module point down, while the other two along the bottom row point up. This board will only operate in an RL01.
- Version 2 (Part No. 54-13531), has all four connectors in the bottom row pointing up, as in Figure 2-9. This module will function in an RL01 or an RL02.
- Version 3 (Part No. 54-14025) has the same arrangement of Berg connectors as Version 2, but it also has test lugs (shown in Figure 2-9) that are not on either of the other two modules.

The service jumpers used in these checks and adjustments are listed in Table 9-1.

Table 9-1 Service Jumpers for Drive Logic Module

Version	Defeat Cover Switch	Defeat POS	Defeat SIG	Defeat SK TO	Select Head 1
1	E33-3 to E33-7	TP8 to ground	E17-6 to E17-7	—	—
2	E54-12 to E54-7	TP6 to ground	E10-8 to E10-7	—	—
3	TP19 to TP20	TP6 to ground	TP23 to TP24	TP21 to TP22	—

Tables 2-3, 2-4 and 2-5 list ground points.

In the course of performing some of the alignments, it is necessary to select Head 1 and then later reselect Head 0. The methods for accomplishing this are shown in Table 9-2.

Bit(s)	Name	Function	
11	Data CRC (DCRC) or Header CRC (HCRC) or Write Check (WCE)	<p>If OPI (bit 10) is cleared and this bit is set, a CRC error has occurred when reading the data (DCRC).</p> <p>If OPI (bit 10) is set and bit 11 is also set, the CRC error has occurred on the header (HCRC).</p> <p>If OPI (bit 10) is cleared and bit 11 is set and the function command was a write check, a write check error (WCE) has occurred.</p>	
12	Data Late (DLT) or Header Not Found (HNF)	<p>This bit is set during a write when the silo is empty but the word count has not yet reached zero (meaning that the bus request was ignored for too long). The OPI bit will not be set.</p> <p>This bit will be set during a read when the silo is full (meaning that the word being read could not enter the silo and the bus request has been ignored for too long). The OPI bit will not be set.</p> <p>When this bit and OPI are both set, a 200 ms timeout occurred while the controller was searching for the correct sector to read or write (no header compare – HNF).</p>	
Error Summary			
Bits			
Error	12	11	10
OPI	0	0	1
Read Data			
CRC	0	1	0
Write Check	0	1	0
Header CRC	0	1	1
Data Late	1	0	0
Header Not Found	1	0	1
13	Non-Existent Memory (NXM)	This bit is set when the addressed memory does not respond within the proper time frame during a direct memory access (DMA) data transfer.	

Bit(s)	Name	Function
14	Drive Error (DE)	This bit is tied directly to the DE interface line. When set, it indicates that the selected drive has flagged an error. (The source of the error can be determined by executing a Get Status command.) DE can be cleared by executing a Get Status command with bit 3 of the DA register set.
15	Composite Error (ERR)	When set, this bit indicates that one or more of the error bits (bits 10-14) is set. If the IE bit (bit 6 of CS) is set and an error occurs (which sets bit 7), an interrupt will be initiated.

774402

BUS ADDRESS REGISTER (BAR)

15	14	13	12	11	10	09	08	07	06	05	04	03	02	01	00
BA15	BA14	BA13	BA12	BA11	BA10	BA9	BA8	BA7	BA6	BA5	BA4	BA3	BA2	BA1	0

READ/WRITE

C2-2035

Bit(s)	Name	Function
0-15	BA0 thru BA15	These bits point to the Unibus address that data is to be transferred to/from. Normally a memory address. BA16 and BA17 are in the CSR bits 4 and 5.

774404

DAR DURING SEEK COMMAND

15	14	13	12	11	10	09	08	07	06	05	04	03	02	01	00
DF8	DF7	DF6	DF5	DF4	DF3	DF2	DF1	DF0	0	0	HS	0	DIR	0	1

C2-2010

Bit(s)	Name	Function
0	-	Must be a 1.
1	-	Must be a 0.
2	Direction (DIR)	This bit indicates the direction in which a seek is to take place. When the bit is set, the heads move toward the spindle (to a higher cylinder address). When the bit is cleared, the heads move away from the spindle (to a lower cylinder address). The actual distance moved depends on the cylinder address difference (bits 7-15).

With the RES command: Use TESTS, PASS, FLAGS and/or UNITS to be tested; e.g., DS-C>RES/TESTS:6/UNITS:1 (this will run only test 6 on the device specified in "P" table 1).

With the other commands:

CON command: Use PASS or FLAGS only
 PRO command: use FLAGS only
 DRO command: use UNITS only
 DIS command: use UNITS only
 ADD command: use UNITS only
 PRI command: no variations
 FLA command: no variations
 ZFL command: no variations
 CCI command: use TESTS, PASS or FLAGS

8.4.2 Console Controls

- Control "C" causes testing to cease and a return to the start (DS-C>).
- Control "Z" causes default values to be taken in any of the three operator dialogues.
- Control "O" causes a suppression of typeouts for the remainder of the diagnostic or until another control "O" is typed.

8.4.3 Hardware Questions

- Supervisor "P" (Parameter) tables are built here, one for every unit to be tested.
- "UNITS" pertains to the "P" table number, not the device unit number. If there is doubt as to which unit number has been assigned to which drive, the DIS command (see above) will supply the necessary information.

8.4.4 Software Question

"CHANGE SW(L)?" asks if any of the software parameters are to be changed. A "Y" will cause various questions to be asked. For details, refer to the individual program document.

3. Program Parameter Changes — Type in any combination of the following parameters to affect the indicated commands.

With the STA command:

- a. DS-C>STA/TESTS: Insert test numbers shown in the appropriate diagnostic listing; e.g., 1:2 means tests 1 and 2, or 1-5:8-10 means tests 1 through 5 and 8 through 10.
- b. DS-C>STA/TESTS:6/PASS: Insert the number of passes the diagnostic should take before halting.
- c. DS-C>STA/TESTS:6/PASS:2/FLAGS: Insert any of these mnemonic(s) representing a program flag(s):
- HOE — Halt On Error
 - LOE — Loop On Error
 - IER — Inhibit Error Report
 - IBE — Inhibit Basic Error reporting
 - IXE — Inhibit eXtended Error reporting
 - PRI — PRInt messages on line printer
 - PNT — PriNT test numbers as they are being executed
 - BOE — Bell On Error
 - UAM — Bypass manual intervention tests
 - ISR — Inhibit Statistical Reports
 - IDR — Inhibit DRopping of units
- d. DS-C>STA/TESTS:BOE:IDR/EOP: Insert a number equalling the pass intervals at which the end of pass message will be printed; e.g., every other pass, every third pass, etc.

EXAMPLE:

Using all the possible parameter changes, the STA command would look like this:

DS-C>STA/TESTS:6/PASS:2/FLAGS:IER:PNT:
BOE:IDR/EOP:3

Bit(s)	Name	Function
3	-	Must be a 0.
4	Head Select (HS)	Indicates which head (disk surface) is selected. A one indicates the lower head; a zero, the upper head.
5-6	-	Reserved.
7-15	Cylinder Address Difference DF 08:00	Indicates the number of cylinders the heads are to move on a seek.

774404

DAR DURING READING OR WRITING DATA COMMANDS

15	14	13	12	11	10	09	08	07	06	05	04	03	02	01	00
CAB	CA7	CA6	CA5	CA4	CA3	CA2	CA1	CA0	HS	SA5	SA4	SA3	SA2	SA1	SA0

C2-2011

Bit(s)	Name	Function
0-5	Sector Address SA 05:00	Address of one of the 40 sectors on a track.
6	Head Select (HS)	Indicates which head (disk surface) is to be selected. A one indicates the lower head; a zero, the upper head. The correct track (head and cylinder) must be previously selected by a Seek.
7-15	Cylinder Address CA 08:00	Address of the cylinder being accessed.

774404

DAR DURING GET STATUS COMMAND

15	14	13	12	11	10	09	08	07	06	05	04	03	02	01	00
X	X	X	X	X	X	X	X	0	0	0	0	RST	0	1	1

C2-2017

Bit(s)	Name	Function
0	-	Must be a 1.
1	Get Status (GS)	Must be a 1, indicating to the drive that the status word is being requested. At the completion of the Get Status command, the drive status word is read into the controller Multipurpose (MP) register.
2	-	Must be a 0.

Bit(s)	Name	Function
3	Reset (RST)	When this bit is set, the drive clears its error register before sending a status word to the controller.
4-7	-	Must be a 0.
8-15	-	Not used during a Get Status.

774406

MPR AFTER GET STATUS COMMAND

15	14	13	12	11	10	09	08	07	06	05	04	03	02	01	00
WDE	CHE	WL	SKTO	SPE	WGE	VC	DSE	DT	HS	CO	HO	BH	STC	STB	STA

CZ-2012

Bit(s)	Name	Function
0-2	State C:A ST C:A	These bits define the state of the drive.

State Bit Definitions

Bit	Bit	Bit	Definition
C	B	A	
0	0	0	Load Cartridge
0	0	1	Spin Up
0	1	0	Brush Cycle
0	1	1	Load Heads
1	0	0	Seek (Track Counting)
1	0	1	Lock On (Keeping on track)
1	1	0	Unload Heads
1	1	1	Spin Down

3	Brush Home (BH)	Set when the brushes are home.
4	Heads Out (HO)	Set when the heads are over the disk.
5	Cover Open (CO)	Set when the drive access cover is open or the dust cover is not in place.
6	Head Select (HS)	Indicates the currently selected head. A zero indicates the upper head; a one, the lower head.
7	Drive Type (DT)	A zero indicates an RL01; a one, an RL02.
8	Drive Select Error (DSE)	Set when a multiple drive selection is detected.
9	Volume Check (VC)	Set when a cartridge is spun up. Cleared by execution of a Get Status command with Bit 3 asserted.

- The prompt "DS-C>" is requesting one of eleven superior "commands," which are:
 - STA — STAr diagnostic and then produce questions for generation of the diagnostic parameter ("P") tables.
 - RES — REStart diagnostic at the point following the hardware questions. The "P" tables set up by the STA command will be used.
 - CON — CONtinue the diagnostic at the beginning of the subroutine that was being executed when the diagnostic was halted by an error or a control "C".
 - PRO — PROceed testing with the diagnostic at the starting address of the subroutine following the one that caused the error report.
 - DIS — DISplay the hardware "P" tables for all the drives being tested.
 - DRO — DROp the desired units from being tested. "UNITS," in this case refers to the "P" table unit numbers, not necessarily the device unit numbers. The DIS command will give the operator the device unit number.
 - ADD — ADD units back into the testing sequence after they had been dropped by the DRO command.
 - PRI — PRInt any performance or statistical tables accumulated by the diagnostic.
 - FLA — FLAGs command — The current setting of all the flags set up under the STA command are printed out for inspection.
 - ZFL — Zero FLAGs command — All current flags set up by the STA command are cleared by this command.
 - CCI — Create Core Image command — This command enables a BIC file to be created on these diagnostics to be run under the XXDP media. (See listing for directions.)

8.2 RL V11 DIAGNOSTICS

The RL V11 subsystem is tested with the same set of diagnostics as the RL11 except that the RL V11 required an additional test (CVRLAA0) for the MAINT command. Kit number ZJ285 includes kit ZJ283 plus CVRLAA0. Since CVRLAA0 is a diskless controller test it can handle either an RL01 or an RL02.

8.3 RL8-A DIAGNOSTICS

The original set of diagnostics (Table 8-3) could handle only the RL01 drives. The new set of diagnostics (Table 8-4) can handle RL02 only (except AJRLAC0 which can handle either an RL01 or an RL02). Kit number ZF241 includes the six diagnostics plus the DECX8 module.

Table 8-3 RL8-A/RL01 Diagnostics

Name	Description
AJRLAA0	Diskless Control Test
AJRLBA0	Drive Test #1
AJRLCA0	Drive Test #2
AJRLDA0	Compatibility Verification
AJRLFA0	Performance Exerciser
AXRLAA0	DECX8 Module
AJRLGA0	Pack Verification

Table 8-4 RL8-A/RL02 Diagnostics

Name	Description
AJRLAC0	Diskless Control Test
AJRLHA0	Seek/Function
AJRLIA0	Read/Write
AJRLJA0	Drive Compatibility
AJRLKA0	Performance Exerciser
AJRLLA0	Pack Verify
AXRLBA0	DECX8 Module

8.4 DIAGNOSTIC SUPERVISOR

8.4.1 Hardcore Questions

- The statement "TYPE TWO CHARACTERS FOUR SECONDS APART" will be asked when no clock is on the system. The system will then subdivide the spacing for use as a clock.

Bit(s)	Name	Function
10	Write Gate Error (WGE)	Set during Write Gate if one or more of the following conditions occur. <ul style="list-style-type: none"> • Drive is not "Ready to Read/Write" • Drive is Write Protected • Sector pulse is occurring • Drive has another error
11	Spin Error (SPE)	Set when spindle has not reached speed in the required time during spin-up or when spindle speed is too high.
12	Seek Time Out Error (SKTO)	Set when the heads do not come on track in the required time during a Seek command or when "Ready to Read/Write" is lost while the drive is in position (lock-on) mode.
13	Write Lock (WL)	Set when the drive is Write Protected.
14	Current Head Error (CHE)	Set if Write Current is detected in the heads when Write Gate is not asserted.
15	Write Data Error (WDE)	Set if Write Gate is asserted but no transitions are being detected on the Write Data line.

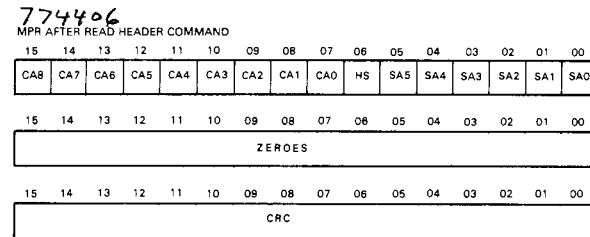

Bit(s)	Name	Function
0-5	SA0:SA5	Sector Address
6	HS	Head Select — Upper head=0, lower head=1
7-15	CA0:CA8	Cylinder Address

774406

MPR DURING READ/WRITE COMMANDS FOR WORD COUNT

16	14	13	12	11	10	09	08	07	06	05	04	03	02	01	00
1	1	1	WC12	WC11	WC10	WC9	WC8	WC7	WC6	WC5	WC4	WC3	WC2	WC1	WCO

CZ-2026

Bit(s)	Name	Function
0-12	Word Count WC 12:00	Contains the two's complement of total number of words to be transferred.
13-15		Must be ones.

MP Register Programming Note — The RL01/RL02 Disk Drive will not do spiral read/writes. If data is to be transferred past the end of the last sector of a track, it is necessary to break up the operation into the following steps.

1. Program the data transfer to terminate at the end of the last sector of the track.
2. Program a seek to the next track. This can be either a head switch to the other surface but same cylinder or a head switch and move to the next cylinder.
3. Program the data transfer to continue at the start of the first sector at the next track.

5.2 RL8-A Instruction Set and Register Summary

Table 5-2 RL8-A Instruction Set

Octal Code	Mnemonic	Function
6600	RLDC	Clear controller, all registers, AC and flags. (Do not use to terminate a disk function.)
6601	RLSD	Skip on function done. Then clear if set to a one.
6602	RLMA	Load break MA register from AC 0:11
6603	RLCA	Load command register A from AC 0:11
6604	RLCB	Load command register B from AC 0:11, execute command
6605	RLSA	Load sector address register from AC 0:5

CHAPTER 8 DIAGNOSTICS

8.1 RL11 DIAGNOSTICS

The original set of six diagnostics (Table 8-1) drove an RL01 only. They were replaced by a new set of seven diagnostics (Table 8-2) that can handle RL01s and RL02s. The kit number for the new set is ZB283. One of the programs (CZRLMA0) in the new set is a utility rather than a test. It is used to examine the Bad Sector File and to write entries into the field-written portion of that file. The original DECX11 module (RLAA) can handle RL01 only while revision B (RLAB) can handle both RL01 and RL02. This module is part of Option Library #5 (DXQLQ). There is an RL driver available for M.P.G.

Table 8-1 RL11/RL01 Diagnostics

Name	Description
CZRLAB0	Controller Test #1
CZRLBB0	Controller Test #2
CZRLCB0	Drive Test #1
CZRLDB0	Drive Test #2
CZRLFB0	Performance Exerciser
CZRLFB0	Compatibility Test

Table 8-2 RL11/RL02 Diagnostics

Name	Description
CZRLGA0	Controller Test #1
CZRLHA0	Controller Test #2
CZRLIA0	Drive Test #1
CZRLJA0	Drive Test #2
CZRLKA0	Performance Exerciser
CZRLLA0	Compatibility Test
CZRLMA0	Bad Sector File Utility

Table 5-2 RL8-A Instruction Set (Cont)

Octal Code	Mnemonic	Function
6607	RLWC	Load word count register from AC 0:11
6610	RRER	Read error register into AC 0, 1, 2, 10, 11
6611	RRWC	Read word count register into AC 0:11
6612	RRCA	Read command register A into AC 0:11
6613	RRCB	Read command register B into AC 0:11
6614	RRSA	Read sector address register into AC 0:5
6615	RRSI	Read silo word into AC 0:11
6617	RLSE	Skip on composite error, then clear if set to a one.

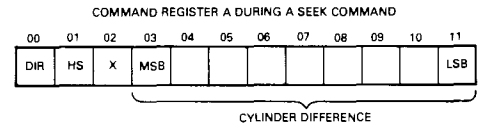

CZ-2016

Bit(s)	Name	Function
AC0	Direction (DIR)	This bit indicates the direction in which a seek is to take place. When the bit is set, the heads move toward the spindle (to a higher cylinder address). When the bit is cleared, the heads move away from the spindle (to a lower cylinder address). The actual distance moved depends on the cylinder address difference (bits 3-11).
AC1	Head Select (HS)	Indicates which head (disk surface) is to be selected. A one indicates the lower head; a zero, the upper head.
AC2	-	Spare
AC3:11	Cylinder Address Difference	Indicates the number of cylinders the heads are to move on a seek.

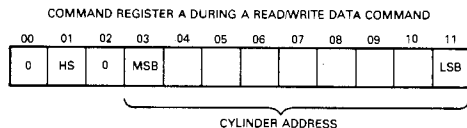

CZ-2017

Bit(s)	Name	Function
AC0	-	Must be zero
AC1	Head Select (HS)	Indicates which head (disk surface) is to be selected. A one indicates the lower head; a zero, the upper head. The correct track (head and sector) must be previously selected by a Seek.
AC2	-	Must be zero
AC3:11	Cylinder Address	Cylinder address.

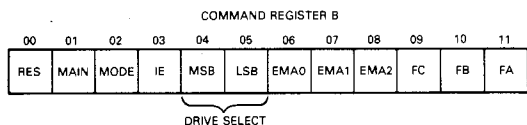

CZ-2018

Bit(s)	Name	Function
AC0	-	Reserved
AC1	Maintenance	The contents of the Disk Address (DA) register are looped back to the silo for maintenance purposes. Bit 2 of Command Register B must also be set for this function to work correctly.
AC2	Mode	When set, this bit indicates that the data field will be 256 8-bit words per sector. When zero, the data field will be truncated to 170 12-bit words per sector. This bit must be set when a Maintenance, a Get Status or a Read Header command is to be executed.
AC3	Interrupt Enable (IE)	When this bit is set, the controller is allowed to interrupt the processor at the conclusion of a normal command or error termination.

1042	012710	
1044	000006	
1046	105710	Wait
1050	100376	
1052	012710	Read Header to kill time for SKTO.
1054	000010	
1056	000205	Return

7.6 OSCILLATING SEEK FOR RL8-A

The following program will cause unit 0 to perform an oscillating seek. To drive units other than 0, swap unit number plugs. Insert the number of cylinders into the switches before starting at location 200. The usual values for the switch register are: 1 cyl=1, 85 cyl=125, 170 cyl=252, 255 cyl=377 and 511 cyl=777.

200	7201	Reset
201	6604	
202	7604	Get number
203	4221	Go Wait for Ready
204	3225	Store number
205	1225	
206	6603	Seek
207	7325	
210	6604	
211	4221	Go Wait for Ready
212	7307	Read Header to Delay for SKTO
213	6604	
214	1225	
215	1226	Change Direction Bit
216	7500	Check for Time to Restore
217	5202	Loop to Start
220	5203	Loop
221	0000	Wait for Ready
222	6601	
223	5222	
224	5621	
225	0000	Temp
226	4000	Constant

7.5 OSCILLATING SEEK FOR RL11/RLV11

The following program will cause unit zero to perform an oscillating seek. To drive units other than unit 0, swap the unit number plugs or modify locations 1044 and 1054 to reflect the unit number in bits 8 and 9.

The number of cylinders involved is inserted into bits 15 through 7 and bit 0 is set in the switch register before starting the programs at 1000. If no switch register is available, modify location 1012 from 177570 to 001060 and put the number of cylinders in bits 15 through 7 and set bit 0 in location 1060.

The common values for the switch register are:

Number of cylinders (in decimal)	Value of Switch Register (in octal)
1	000205
85	025205
170	052405
255	077605
511	177605

1000	012706	Set Stack Pointer
1002	001000	
1004	012700	Set Device Address into R0
1006	174400	
1010	013701	Set Difference into R1
1012	177570	
1014	004537	Go Seek
1016	001032	
1020	042701	Change direction bit in R1
1022	000004	
1024	004537	Go Seek
1026	001032	
1030	000767	Loop back
1032	105710	Wait
1034	100376	
1036	010137	Seek
1040	174404	

Bit(s)	Name	Function
AC4:5	Drive Select (DS0, DS1)	These bits determine which drive will communicate with the controller via the drive bus.
AC6:8	Extended Memory Addressed (EMA)	These three bits define the memory field location. This allows up to 32K memory locations to be addressed on processors having more than 4K of memory.
AC9:11	Function Code (FC, FB, FA)	These bits indicate the command to be executed by the controller/disk subsystem.

Bit 9	Bit 10	Bit 11	Command
0	0	0	Maintenance
0	0	1	Reset
0	1	0	Get Status
0	1	1	Seek
1	0	0	Read Header
1	0	1	Write Data
1	1	0	Read Data
1	1	1	Read Data Without Header Check

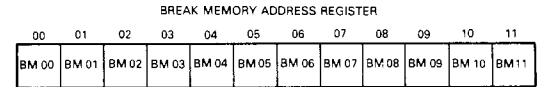

CZ-2019

Bit(s)	Name	Function
AC0:11	BM0:11	Memory Address

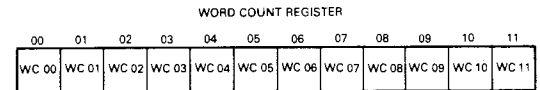

CZ-2020

Bit(s)	Name	Function
AC0:11	WC0:11	Word Count

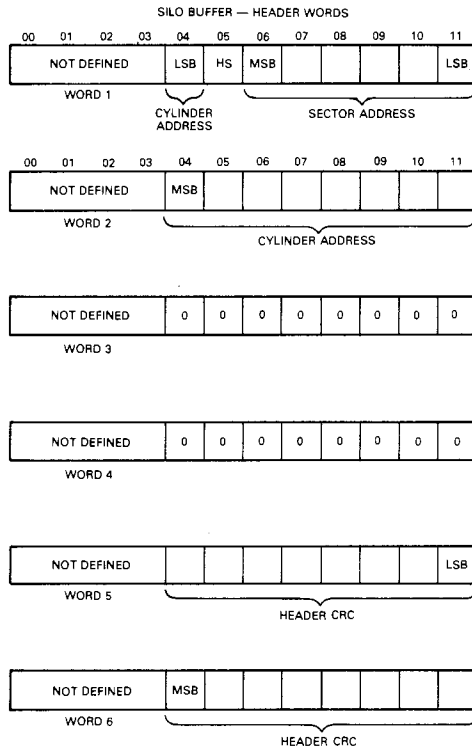
**WORD 1 — HEADER**

Bit(s)	Name	Function
AC0:3	-	Undefined
AC4	Cyl Add	LSB of Cylinder Address
AC5	HS	Head Select — lower head = 1, upper head = 0
AC6:11	Sec Add	Sector Address

WORD 2 — HEADER

Bit(s)	Name	Function
AC0:3	-	Undefined
AC4:11	Cyl Add	Cylinder Address — eight high order bits

On some PDP-11 systems this can be accomplished manually using the console. On other PDP-11 systems it is necessary to run a program such as given below. Start at 1000 and when it halts, examine memory location 1032.

To get status on unit 1, 2, or 3 modify location 1010 to 404, 1004, or 1404.

To reset drive modify location 1002 to 13.

1000	012737	Get Status Command
1002	000003	Use 13 to Reset
1004	174404	
1006	012737	
1010	000004	Use 404, 1004, 1404 for Units 1, 2, 3
1012	174400	
1014	105737	Wait
1016	174400	
1020	100375	
1022	013737	Move Result to Memory
1024	174406	
1026	001032	
1030	000000	Halt
1032	000000	Result

7.4 GET STATUS ON AN RL8-A SUBSYSTEM

The following program will GET STATUS from unit 0. To access unit 1, 2, 3 change location 212 to 1102, 1202, 1302.

Start the program at 200 — at the first halt, the first byte of the status word is displayed in the accumulator — at the second halt, the second byte is displayed.

200	7300	
201	1212	Get Status
202	6604	
203	6601	Wait
204	5203	
205	6615	Get First Byte
206	7402	Halt and Display First Byte
207	6615	Get Second Byte
210	7402	Halt and Display Second Byte
211	5200	Jump to Start
212	1002	Constant

7.2 HEAD SELECTION PROGRAM FOR RL8-A

The following program causes Head 1 (lower head) to be selected (on unit 0) if the WRITE PROTECT switch is in and Head 0 (upper head) to be selected if the switch is out.

200	6600	Clear Controller
201	1234	
202	6604	Get Status Command
203	6601	Wait
204	5203	
205	6615	First Word of Status
206	0232	
207	7640	Check HS Bit
210	5217	HS=1, Go to 217
211	6615	Second Word of Status
212	0233	
213	7650	Check WL Bit
214	5201	HS=WL, Go to 201
215	7332	
216	5224	
217	6615	Second Word of Status
220	0233	
221	7640	Check WL
222	5201	HS=WL, Go to 201
223	7300	
224	6603	HS to Command REG A
225	7325	
226	6604	Seek Command to Command REG B
227	6601	Wait
230	5227	
231	5201	Loop to 201
232	0100	Constant
233	0040	Constant
234	1002	

7.3 GET STATUS (WITH OR WITHOUT RESET) ON AN RL11/RLV11 SUBSYSTEM

To accomplish this it is necessary to:

- 1) Deposit a 3 into DAR at 774404 (or 13 to Reset)
- 2) Deposit a 4 into CSR at 774400 (or 404, 1004, 1404 for units 1, 2, 3)
- 3) Wait for operation to be complete
- 4) Examine contents of MPR at 774406.

WORD 3 — HEADER

Bit(s)	Name	Function
AC0:3	-	Undefined
AC4:11	-	Zeros

WORD 4 — HEADER

Bit(s)	Name	Function
AC0:3	-	Undefined
AC4:11	-	Zeros

WORD 5 — HEADER

Bit(s)	Name	Function
AC0:3	-	Undefined
AC4:11	CRC	Eight LSB of CRC word

WORD 6 — HEADER

Bit(s)	Name	Function
AC0:3	-	Undefined
AC4:11	CRC	Eight MSB of CRC word

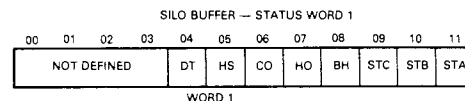

CZ-2023

Bit(s)	Name	Function
AC0:3	-	Undefined
AC4	Drive Type	A zero indicates an RL01; a one, an RL02.
AC5	Head Select (HS)	Indicates currently selected head. A zero indicates the upper head; a one, the lower head.
AC6	Cover Open (CO)	Set when the drive access cover is open or the dust cover is not in place.
AC7	Heads Out (HO)	A one indicates that the heads are over the disk; a zero indicates that the heads are home.

Bit(s)	Name	Function
AC8	Brush Home (BH)	Set when the brushes are home.
AC9:11	State Bits	These bits define the state of the disk drive.

State Bit Definitions

Bit	Bit	Bit	Definition
C	B	A	
0	0	0	Load Cartridge
0	0	1	Spin-up
0	1	0	Brush Cycle
0	1	1	Load Heads
1	0	0	Seek (Track Counting)
1	0	1	Lock-on (keeping on track)
1	1	0	Unload Heads
1	1	1	Spin-down

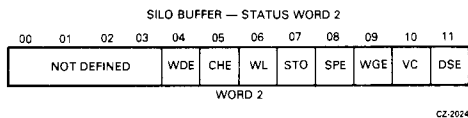

Bit(s)	Name	Function
AC0:3	-	Undefined
AC4	Write Data Error (WDE)	This bit is set when the Write Gate is on but no transitions were detected on the Write Data line.
AC5	Current Head Error (CHE)	This bit is set when Write Current is detected in the heads but the Write Gate was not asserted.
AC6	Write Lock (WL)	Set when the drive is Write Protected.
AC7	Seek Time Out Error (SKTO)	Set when the heads do not come on track in the required time during a Seek command or when "Ready to Read/Write" is lost while the drive is in position (lock-on) mode.
AC8	Spin Error (SPE)	Set when the spindle does not come up to speed within 40 seconds or when the spindle speed is too high.

**CHAPTER 7
TOGGLE-IN PROGRAMS**

7.1 HEAD SELECTION PROGRAM FOR RL11/RLV11

The following program causes Head 1 (lower head) to be selected (on unit 0) if the WRITE PROTECT switch is in and Head 0 (upper head) to be selected if the switch is out.

1000	012700	Housekeeping
1002	174400	
1004	012701	
1006	174404	
1010	105710	Wait
1012	100376	
1014	012711	Get Status Command
1016	000013	
1020	012710	
1022	000004	
1024	105710	Wait
1026	100376	
1030	013702	Status Word
1032	174406	
1034	006302	
1036	010203	
1040	006303	
1042	105702	Check HS Bit
1044	100405	
1046	005703	Check WL Bit
1050	100357	Equal, Loop
1052	012711	Set HS Bit
1054	000021	
1056	000404	Go to Seek Command
1060	005703	Check WL Bit
1062	100752	Equal, Loop
1064	012711	Reset HS Bit
1066	000001	
1070	012710	Seek Command
1072	000006	
1074	000745	Loop

AC9	Write Gate Error (WGE)	Set if Write Gate is asserted and one or more of the following conditions is true. 1. Drive is not "Ready to Read/Write" 2. Drive is Write Protected 3. Drive is in the midst of sector time 4. Drive has another error asserted
AC10	Volume Check (VC)	Set when a cartridge has been spun up. This bit is reset by a Reset command.
AC11	Drive Select Error (DSE)	Set when one or more drives have the same number (unit select plug) or have responded to the same number.

SECTOR ADDRESS REGISTER

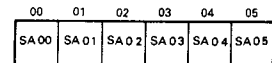

CZ-2021

Bit(s)	Name	Function
AC0:5	SA0:5	Sector Address

ERROR REGISTER

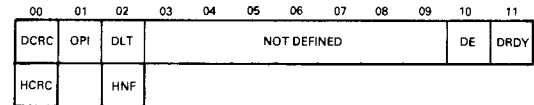

CZ-2022

Bit(s)	Name	Function
AC0	Data CRC (DRCR) or Header CRC (HCRC)	If OPI is cleared and this bit is set, the CRC error occurred in the data (DCRC). If OPI is set and this bit is also set, the CRC error occurred on the header (HCRC).
AC1	Operation Incomplete (OPI)	When set, this bit indicates that the current command was not completed within 200 ms. It is also used in conjunction with bits 0 and 2 of this register.

Bit(s)	Name	Function																											
AC2	Data Late (DLT) or Header Not Found (HNF)	<p>This bit is set during a Write if the silo is empty and the word count is not yet zero (meaning that no word was available for writing). OPI will not be set.</p> <p>This bit is set during a Read if the silo is full and the word count is not yet zero (meaning that the word being read could not enter the silo). OPI will not be set.</p> <p>When this bit and OPI are both set, then a 200 ms timeout occurred while the controller was searching for the correct sector to read or write (no header compare - HNF).</p>																											
AC0:2	Error Code	<p>Summary</p> <table border="1"> <thead> <tr> <th rowspan="2">Error</th> <th colspan="3">Bits</th> </tr> <tr> <th>00</th> <th>01</th> <th>02</th> </tr> </thead> <tbody> <tr> <td>DLT</td> <td>0</td> <td>0</td> <td>1</td> </tr> <tr> <td>OPI</td> <td>0</td> <td>1</td> <td>0</td> </tr> <tr> <td>HNF</td> <td>0</td> <td>1</td> <td>1</td> </tr> <tr> <td>DCRC</td> <td>1</td> <td>0</td> <td>0</td> </tr> <tr> <td>HCRC</td> <td>1</td> <td>1</td> <td>0</td> </tr> </tbody> </table>	Error	Bits			00	01	02	DLT	0	0	1	OPI	0	1	0	HNF	0	1	1	DCRC	1	0	0	HCRC	1	1	0
Error	Bits																												
	00	01	02																										
DLT	0	0	1																										
OPI	0	1	0																										
HNF	0	1	1																										
DCRC	1	0	0																										
HCRC	1	1	0																										
AC10	Drive Error (DE)	<p>This bit is tied directly to the Drive Error interface line. When set, it indicates that the selected drive has flagged an error. The source of the error can be determined by a Get Status.</p> <p>The DE bit is cleared with a Reset command to the drive.</p>																											
AC11	Drive Ready (DRDY)	<p>When set, this bit indicates that the selected drive is ready to receive a command. The bit is cleared when a Seek operation is initiated and set again when the Seek operation is completed.</p>																											

CHAPTER 6 BOOTSTRAPS

6.1 RL11/RLV11 BOOTSTRAP

Ensure that the heads are over cylinder 0 and head 0 is selected by releasing the LOAD switch, waiting for the LOAD indicator to light, then depressing the LOAD switch. After the drive is READY, initialize the controller with a system INITIALIZE. Perform a bit status clear. Load the following program into memory.

LOC	Contents	Comments
10000	012737	Load CSR
10002	000014	
10004	174400	
10006	000001	Wait

Start the program at 10000 and allow it to run for a few seconds. Halt the program and restart at 00000.

6.2 RL8-A BOOTSTRAP

Ensure that the heads are over cylinder 0 and head 0 is selected by releasing the LOAD switch, waiting for the LOAD indicator to light, then depressing the LOAD switch. Load the following program into memory.

LOC	Contents	Comments
21	7600	Clear AC and constant
22	6600	Clear RL8-A
23	7332	Generate constant
24	6605	Load SAR with 20
25	1021	Load constant into AC
26	6607	Load WC
27	7327	Generate constant
30	6604	Load CMD B
31	6601	Skip on done
32	5031	Loop

Start program at 21. The OS*8 monitor will overlay this bootstrap.