

**BULLETIN 310B
VOL 1**

**TECHNICAL MANUAL
33 TELETYPEWRITER SETS
RECEIVE-ONLY (RO)
KEYBOARD SEND-RECEIVE (KSR)
AUTOMATIC SEND-RECEIVE (ASR)**



**TELETYPE[®]
CORPORATION**
5555 TOUHY AVENUE, SKOKIE, ILLINOIS

310B
VOLUME 1

INTRODUCTION

Bulletin 310B is a technical manual that provides general and specific information about the 33 Receive-Only (RO), Keyboard Send-Receive (KSR), and Automatic Send-Receive (ASR) Teletypewriter Sets and their component units.

Volume 1 contains a description of the 33 Teletypewriter Sets and gives installation instructions. Also included in Volume 1 is information on the disassembly and reassembly, lubrication, and principles of operation of the component units of the Teletypewriter Sets. Volume 2 includes adjustment information on all component units of 33 Teletypewriter Sets.

Each volume is made up of a group of appropriate, independent sections. They are separately identified by title and section number, and the pages of each section are numbered consecutively, independent of other sections. The identifying number of a section, a 9-digit number, appears on each page of the section, in the upper left corner of left-hand pages and the upper right corner of right-hand pages.

To locate specific information, refer to the table of contents. Find the name of the involved component in column one and the title of the section in column two. The correct 9-digit section will then be found in column three. The sections are arranged in the order shown in the table of contents. Turn to page one of the section indicated where the contents of that section will be found (except where a section is small and does not require a listing of contents).

The sections comprising this bulletin are now stocked separately and may be individually ordered if the entire bulletin is not required.

FILING INSTRUCTIONS

1. The following filing instructions apply to changes sent to the field.
2. Asterisk (*) in the table of contents indicate changes.
3. When the issue of a section changes, replace the old issue with the attached new one.
4. In the case of addendums, turn to the affected section and follow the instructions on the first page of the attached addendum.
5. Replace the old table of contents with the new one.

TABLE OF CONTENTS

<u>Equipment</u>	<u>Contents</u>	<u>Section</u>	<u>Issue</u>
Teletypewriter Set	General Description and Operation	574-100-101TC	2*
Teletypewriter Set	Circuit Description	574-100-103TC	1
Teletypewriter Set	Installation	574-100-201TC	5*
Teletypewriter Set	Removal and Replacement of Components	574-100-702TC	2*
Keyboard	General Description and Principles of Operation	574-121-100TC	3*
Keyboard	Lubrication	574-121-701TC	3*
Keyboard	Disassembly and Reassembly	574-121-702TC	3*
Typing Unit	General Description and Principles of Operation	574-122-100TC	3*
Typing Unit	Lubrication	574-122-701TC	3*
Typing Unit	Disassembly and Reassembly	574-122-702TC	3*
Call Control Unit	General Description and Operation	574-123-100TC	2*
Tape Reader	General Description and Principles of Operation	574-124-100TC	3*
Tape Reader	Lubrication	574-124-701TC	2
Tape Reader	Disassembly and Reassembly	574-124-702TC	2
Tape Punch	General Description and Principles of Operation	574-125-100TC	3*
Tape Punch	Lubrication	574-125-701TC	3*
Tape Punch	Disassembly and Reassembly	574-125-702TC	2
Cover	General Description	574-126-100TC	2
Cover	Lubrication	574-126-701TC	1

33 TELETYPEWRITER SETS

GENERAL DESCRIPTION AND OPERATION

CONTENTS	PAGE	CONTENTS	PAGE
1. GENERAL	1	4. SET FEATURES	18
2. TELETYPEWRITER SETS	2	5. TYPICAL OPERATION AND APPLICATION	19
RECEIVE-ONLY (RO) TELETYPEWRITER SET	2	33 SET OPERATION	19
KEYBOARD SEND-RECEIVE (KSR) TELETYPEWRITER SET	2	COMPUTER INPUT-OUTPUT SET OPERATION	20
AUTOMATIC SEND-RECEIVE (ASR) TELETYPEWRITER SET	2	A. General Principles of Operation	20
3300 SERIES CODED SETS WITH VARIABLE CUSTOMER ACTIVATED OPTIONS	2	B. Functional Features	21
COMPUTER INPUT-OUTPUT (I/O) SET	9	C. Operator Controls	22
3. COMPONENTS	10	D. On-Line Output	22
33 SETS	10	E. On-Line Input	22
A. Typing Unit	10	F. Off-Line Operation	23
B. Call Control Unit	10	6. TECHNICAL DATA	23
C. Keyboard	10	33 SETS	23
D. Tape Punch	10	COMPUTER I/O SETS	24
E. Tape Reader	10	A. Physical Characteristics	24
3300 SERIES CODED SETS	10	B. Input Power	24
A. Typing Unit	11	C. Electrical Characteristics	24
B. Call Control Unit	13	D. Interface	25
C. Keyboard	13	E. Voltages and Impedances of Data and Control Leads	25
D. Tape Punch	13	F. Data Leads	25
E. Tape Reader	14	G. Transmitter Control Signal Format for Tape Reader and Keyboard	25
COMPUTER INPUT-OUT (I/O) SETS	15	H. Receiver Control Signal Format For Tape Punch and Page Printer	26
A. Typing Unit	15	I. Motor Control	26
B. Call Control Unit	15	J. Operating Modes	26
C. Keyboard	15	K. Environmental Tolerances	26
D. Tape Punch	18	7. VARIABLE FEATURES AND ACCESSORIES	26
E. Tape Reader	18	1. GENERAL	
		1.01 This section provides the general description and operation for Model 33 teletypewriter sets. It is reissued to incorporate the 3300 Series Coded Sets, the	

Computer Input-Output (I/O) Sets, and the latest engineering changes. Since this is a general revision, marginal arrows used to indicate changes and additions have been omitted.

1.02 The 33 teletypewriter sets described in this section are electromechanical apparatus that provide terminal facilities for exchanging recorded communication via appropriate transmission facilities, including telegraph lines, telephone networks, and radio channels.

1.03 Terminals in the 33 line are available with either 50 or 60 Hz motors and can use either teletypewriter paper (friction feed) or accommodate multiple-copy business forms (sprocket feed). They operate at 10 characters per second (110 baud), feature four-row keyboards and utilize ASCII (American National Standard Code for Information Interchange). The sets offer a choice of typewheel-keytop combinations and generate alphas, numerics, and many special control codes in even parity. They also provide answer-back on most configurations. Transmission mode may be half or full duplex. Current interface is standard with E.I.A. RS-232-C available as a modification kit.

1.04 Some of the available equipment that may be used with the 33 terminal (see Part 7 for accessories) include a motor control device that will turn the terminal motors on at the receipt of a line signal; also various paper and tape handling devices. The 4210 Magnetic Tape Terminal may be added for on-line data transmission and reception up to 2400 words per minute (240 Hz). A STUNTRONIC* parity error detector may be added to improve data accuracy, and through signal regeneration, to reduce signal distortion from as high as 45 percent down to less than 5 percent. Model 33 sets, with the addition of Teletype station controllers, can be used in selective calling systems.

1.05 References to left, right, up, down, front, rear, etc., consider the teletypewriter set as viewed by the teletypewriter operator.

1.06 This section covers the following teletypewriter sets:

- (a) Receive-Only (RO) Teletypewriter Set
- (b) Keyboard Send-Receive (KSR) Teletypewriter Set
- (c) Automatic Send-Receive (ASR) Teletypewriter Set
- (d) 3300 Series Coded Sets
- (e) Computer Input-Output (I/O) Set

2. TELETYPEWRITER SETS

RECEIVE-ONLY (RO) TELETYPEWRITER SET (Figure 1)

2.01 The RO set can only receive messages and print them on a paper copy. It has no transmitting capabilities. Essentially the RO consists of two components.

- (a) Typing unit
- (b) Call control unit

KEYBOARD SEND-RECEIVE (KSR) TELETYPEWRITER SET (Figure 2)

2.02 The KSR can receive and transmit messages, and print them on a paper copy or sprocket form. It consists of the following components:

- (a) Typing unit
- (b) Call control unit
- (c) Keyboard

AUTOMATIC SEND-RECEIVE (ASR) TELETYPEWRITER SET (Figure 3)

2.03 The ASR set consists of the following components:

- (a) Typing unit
- (b) Call control unit
- (c) Keyboard
- (d) Tape punch
- (e) Tape reader

2.04 An ASR set can receive and transmit messages. It can print messages on paper copy (or on sprocket form). The tape punch perforates paper tape. The reader senses the code punched in tape which the set can then transmit to the local (itself) or a distant set or sets.

3300 SERIES CODED SETS WITH VARIABLE CUSTOMER ACTIVATED OPTIONS

2.05 A 3300 Series Coded Set (Figures 5 and 6) may be similar to any of the already established sets except that it has been designed and manufactured with or adaptable to the most frequently required features that were previously ordered separately. Most of these features are of the convertible, customer activated option type. The components of these sets are designed so that additional features may be added if desired. For schematic and actual wiring diagrams with circuit description, refer to the Wiring Diagram Package (WDP0316) shipped with the equipment.

*Trademark of Teletype Corporation.

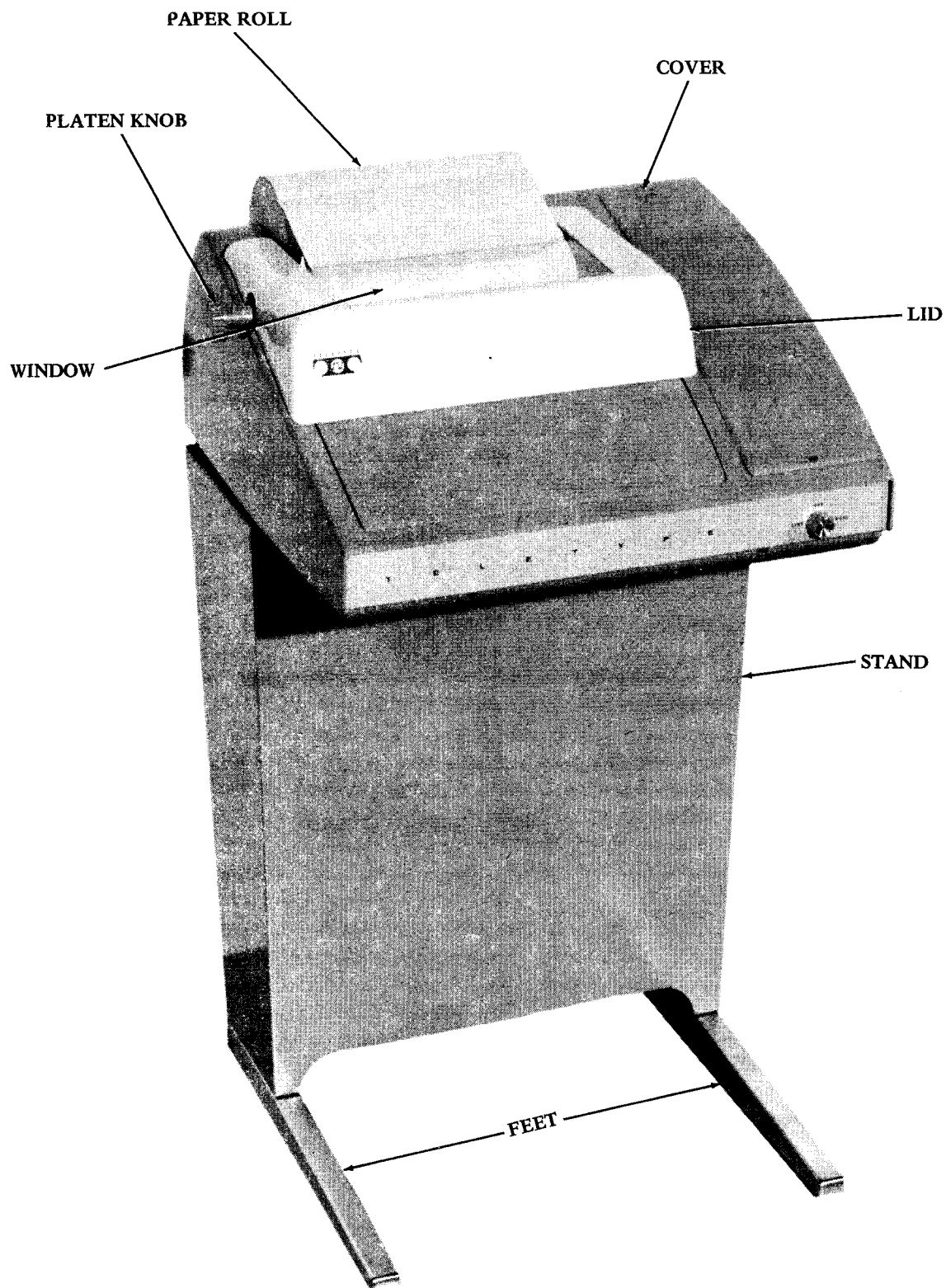

Figure 1 - Model 33 Receive-Only (RO) Teletypewriter Set

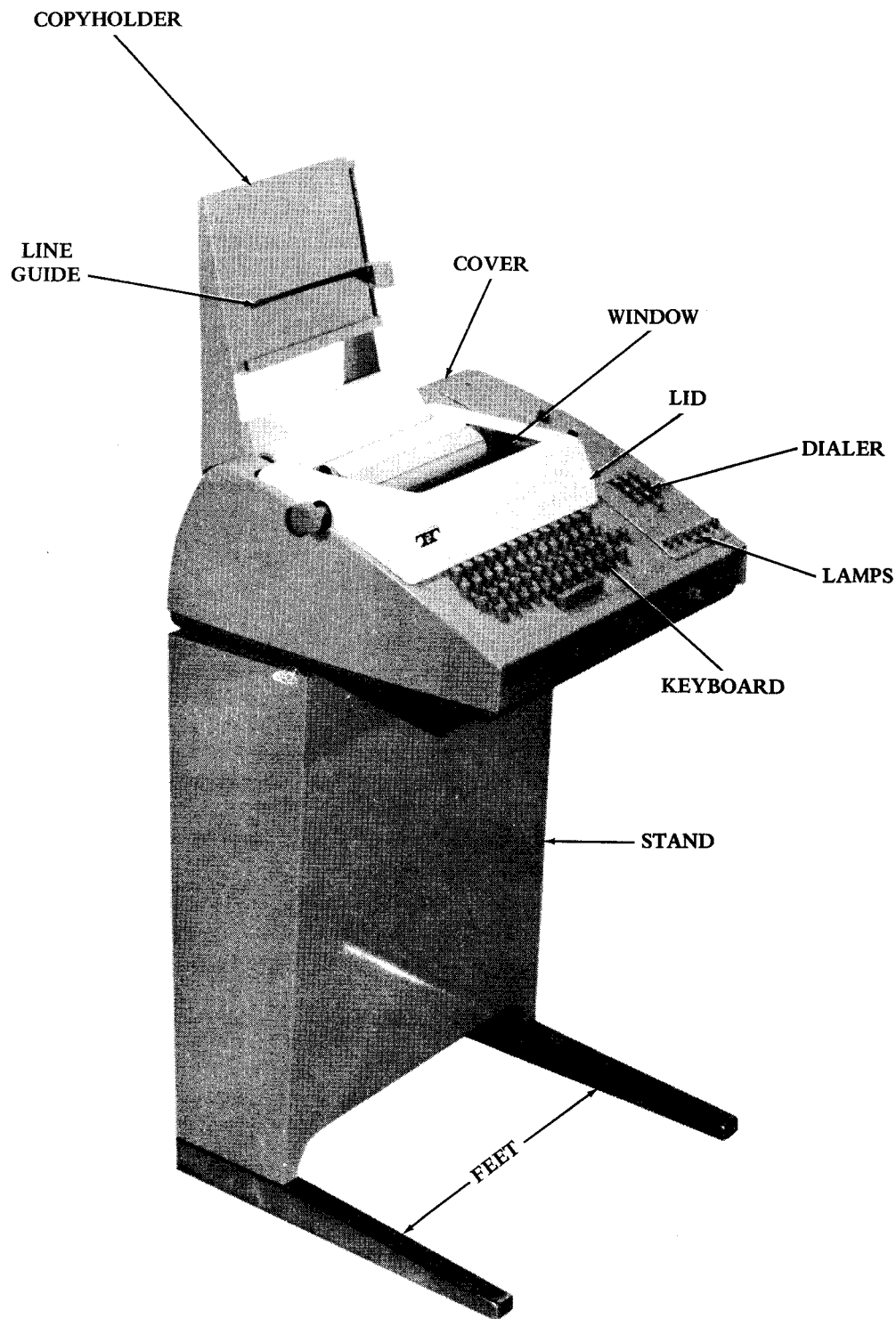

Figure 2 - Model 33 Keyboard Send-Receive (KSR)
Teletypewriter Set

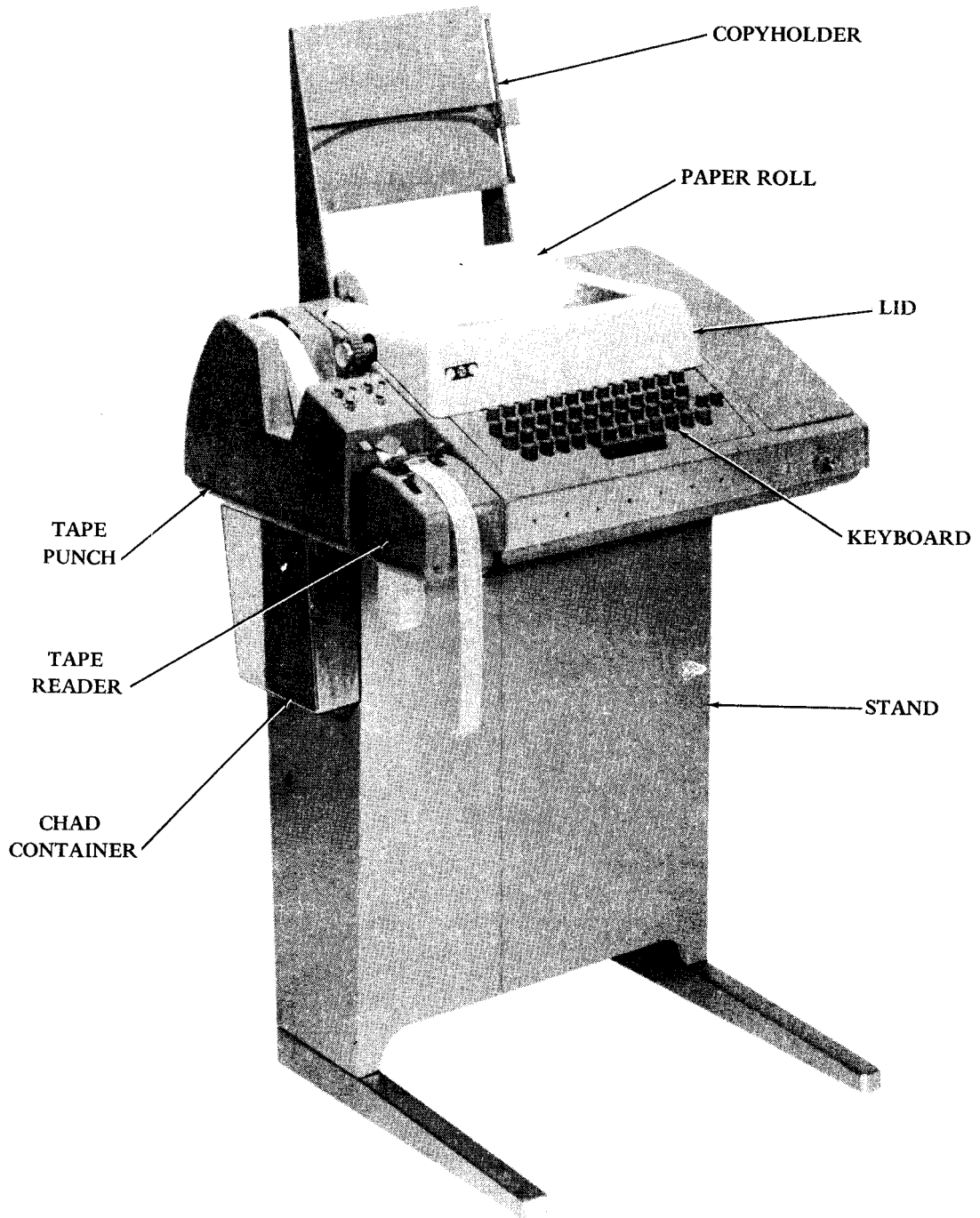

Figure 3 - Model 33 Automatic Send-Receive (ASR)
Teletypewriter Set

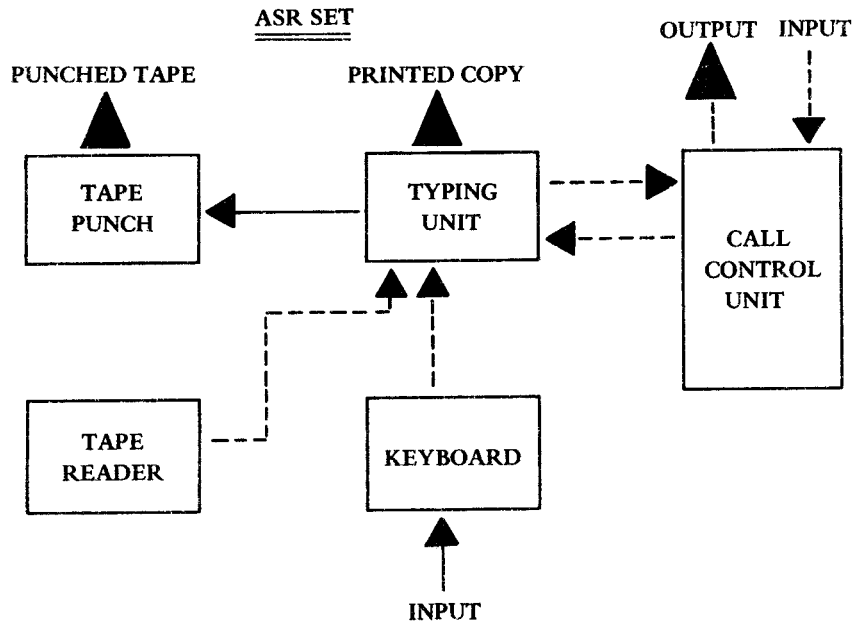
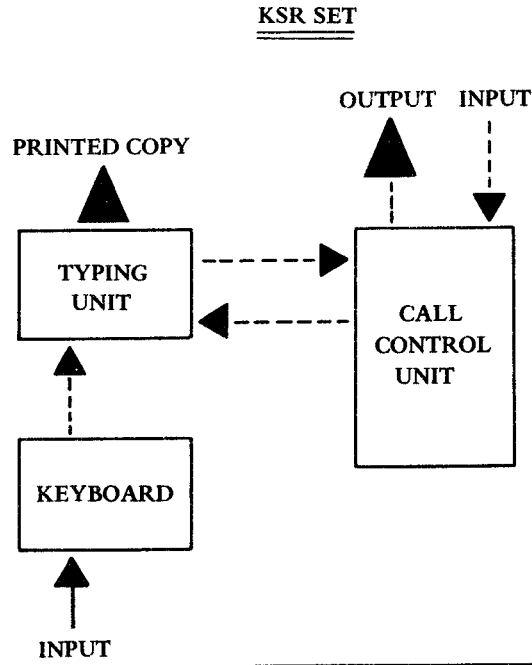
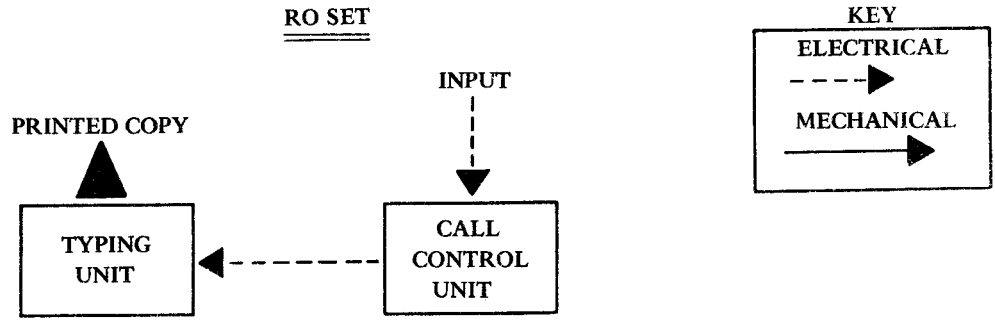

Figure 4 - Block Diagram of 33 Sets

2.06 The 3300 Series Coded Sets introduce a new type wheel and keyboard designed to meet the latest ASCII (refer to Figure 6, and for code description to Section 574-121-100TC). These sets and their components incorporate the following customer activated options:

- (a) Automatic/manual (Auto/Man) tape punch
- (b) Automatic carriage return and line feed (CR/LF) function
- (c) Choice of either automatic/manual (Auto/Man) or manual tape readers

- (d) Parity error detection keyboard
- (e) Distributor trip mechanism for reader and answer-back magnet options.

2.07 Also included as standard features or equipment in 3300 Series Coded Sets are the following:

- (a) Single/double line-feed lever on friction feed typing units
- (b) Choice of standard typewheels, presently available

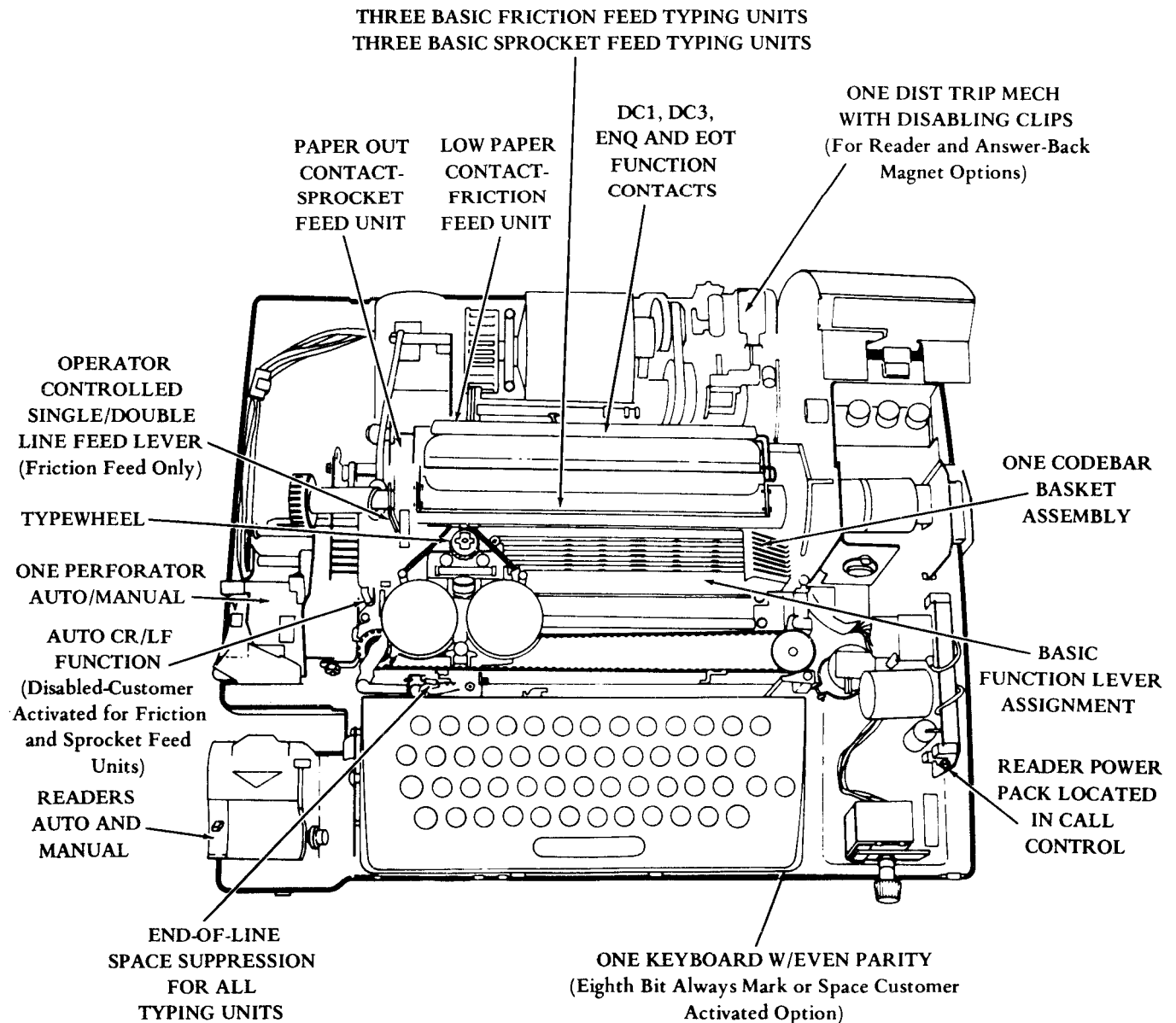
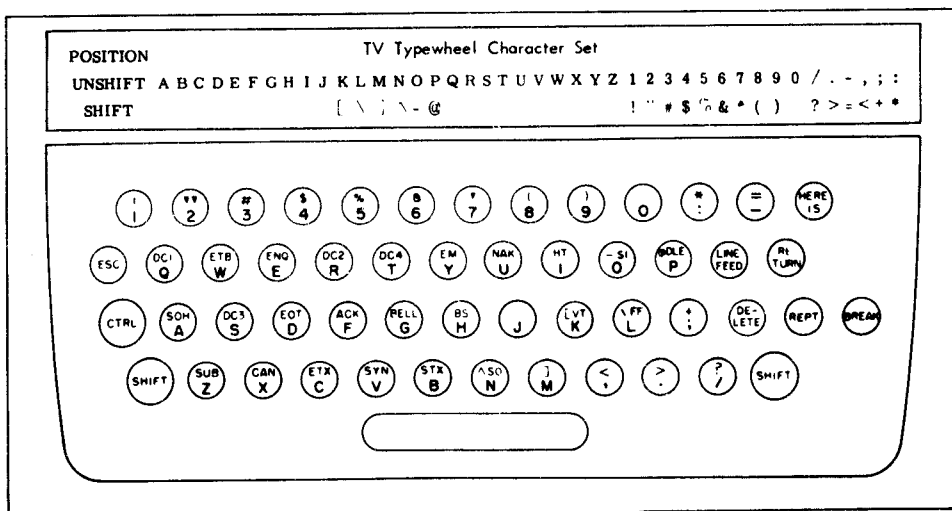

Figure 5 - 3300 Series Coded Set With Cover Removed



FOR ASCII

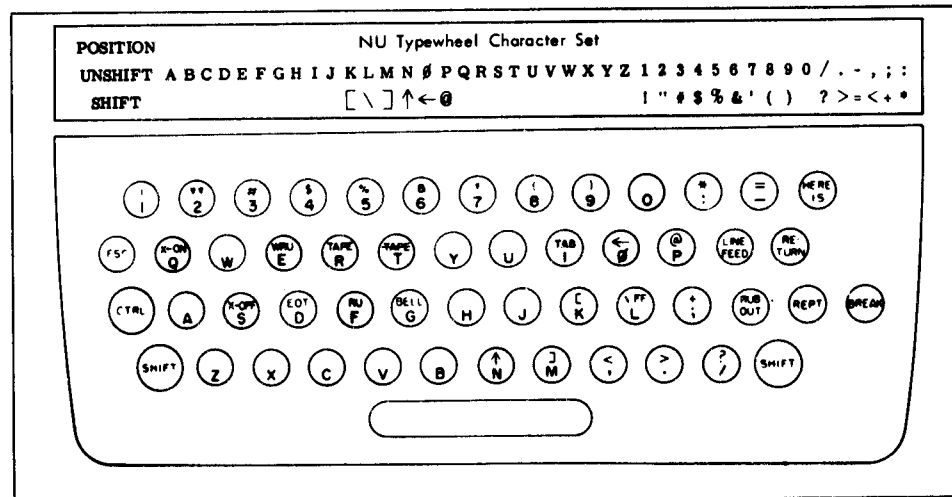
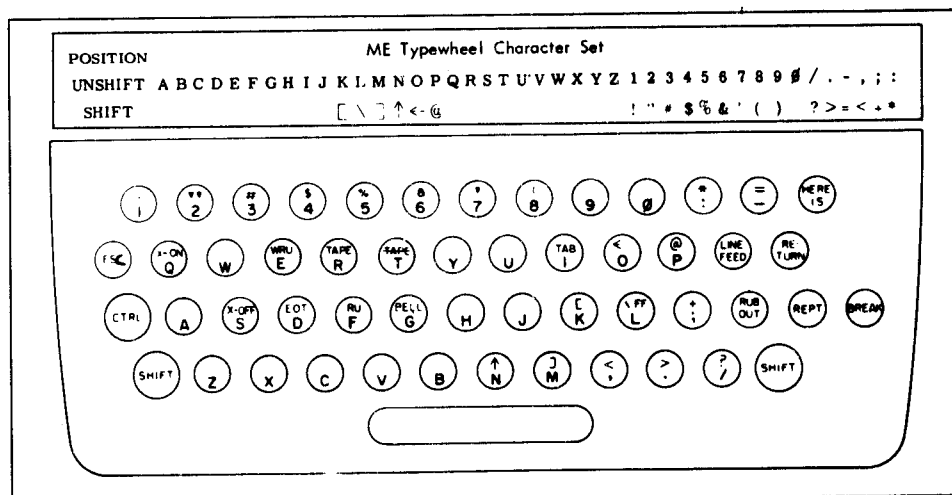

Figure 6 - Typical Typewheel and Keypop Arrangements for 3300 Series Coded Sets

- (c) Choice of standard keyboards (to match the typewheels)
- (d) End-of-line space suppression for all typing units
- (e) Low-paper contact on friction feed typing units
- (f) Paper-out contact on sprocket feed typing units
- (g) Device control DC1 and DC2, enquiry (ENQ), end-of-transmission (EOT) function contacts
- (h) Standard function lever assignment
- (i) One standard codebar basket assembly
- (j) Reader power pack located in call control unit and enclosed in right side of set cover
- (k) Common wiring arrangement and diagrams. Refer to 3.07 for 3300 Series Coded Sets and to the specific sections covering the components for more detailed information.

COMPUTER INPUT-OUTPUT (I/O) SET

2.08 The I/O set is a 33 Automatic Send-Receive Set (Figure 7) that has a special call control unit with 6 manual control key buttons. This set also has a computer interface capability and three solenoids for control of the punch, typing unit, and keyboard in any combination. The set

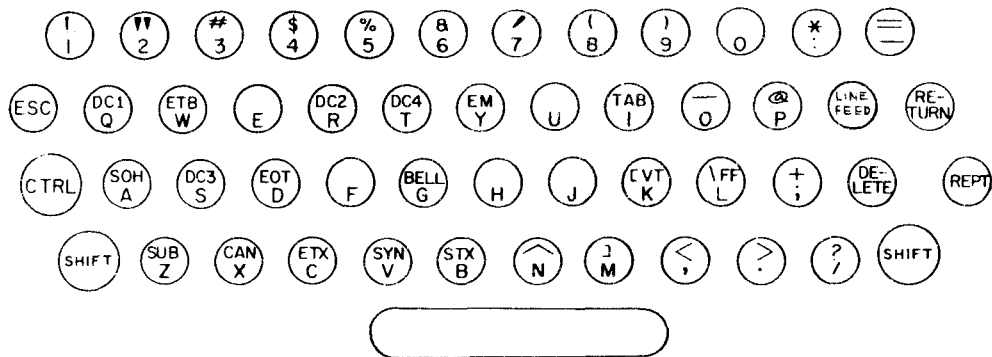
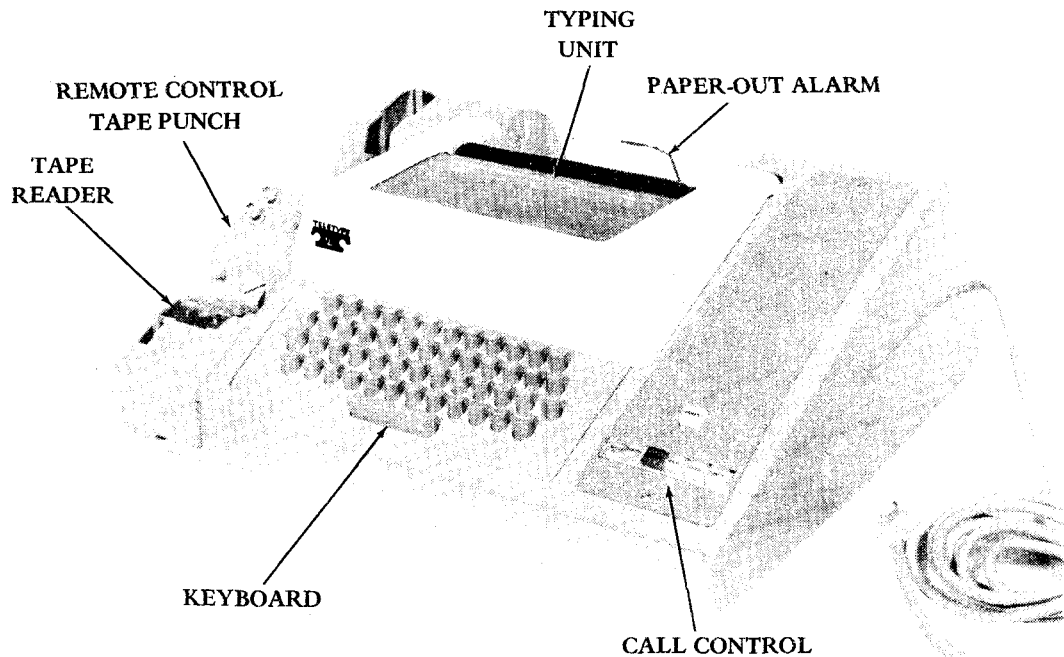

Figure 7 - Computer Input-Output (I/O) Set and Keyboard Arrangement (TP184771)

may be controlled either locally by the operator or remotely by a computer. The I/O sets are available for either 50 or 60 hertz operation.

2.09 An I/O set, when used with a computer, serves as a console operators input/output device and as a computer slave. These sets are intended primarily for use as remote controlled data input/output terminals. Each set operates on an 8-level, 100 wpm (110 baud), ASCII, even parity code.

2.10 Each I/O set consists of a page printer, keyboard, tape punch, tape reader, low tape switch, control unit, and cover.

2.11 These I/O sets provide two modes of operation: local and remote. In local, the printer will monitor keyboard or tape reader generated signals. A PUNCH ON/OFF switch controls the punch in the local mode. In remote, the punch, the signal generating unit, and the monitoring unit are controlled remotely (eg, by a computer).

2.12 A 20-pin connector and cable connects the terminal to the computer. The interface consists of data in and out, control, and terminal status.

3. COMPONENTS

33 SETS

3.01 In this section, only a brief outline of component operation will be presented. Individual components are described in detail each in a separate section. Refer to the following for a general description and principles of operation of the components:

Typing Unit	574-122-100TC
Call Control Unit	574-123-100TC
Keyboard	574-121-100TC
Tape Punch	574-125-100TC
Tape Reader	574-124-100TC

A. Typing Unit

3.02 The typing unit is the receiving component of the set. A signal coming into the typing unit is translated into a mechanical arrangement of codebars. The position of these codebars determines two things: the position of a typewheel upon which characters are embossed, and the selection of functions such as CARRIAGE RETURN and LINE FEED. A motor, by means of a main shaft, supplies all the motive force to effect the printing and

perform the functions. The friction feed set may be considered the standard type of set. It handles 8-1/2 inch paper, and will accommodate 74 characters per line, 10 characters per inch. Vertically the friction feed set will print 6 lines per inch and will normally print one original and one copy.

B. Call Control Unit

3.03 The call control unit serves as a bridge to electrically join the set to the communication networks. In some applications the call control unit serves to initiate, accept, control and complete the incoming calls. A power supply, local-remote control circuits, a selector magnet driver circuit, and a motor delay timer circuit are some of its basic elements.

C. Keyboard

3.04 The keyboard is the sending component of the set. Each of its keys controls an arrangement of levers which, in turn, position electrical contacts to represent the character. The keyboard output is a parallel output to the distributor of the typing unit. The distributor senses the keyboard output and sends it in a serial form to the selector magnet driver. From the selector magnet driver it then goes to the typing unit selector.

D. Tape Punch

3.05 The input to the tape punch is strictly mechanical. Extensions on the typing unit codebars position themselves in the tape punch to set up a similar coded arrangement of punch pins. With drive motion from the typing unit main shaft, the tape punch drives the punch pins to perforate holes in paper tape.

E. Tape Reader

3.06 Sensing pins in the tape reader are driven upward for every cycle. Where holes are present in the tape the sensing pins close a set of contacts. Where no holes are present in the tape the sensing pins are blocked and make no contact. These current, no-current conditions are duplicated on the typing unit distributor as a parallel output. The distributor senses the condition of each pulse and sends it serially to the selector magnet driver in the call control unit. From the call control unit the pulses go to the typing unit to print the character.

3300 SERIES CODED SETS

3.07 In order to increase compatibility with respect to special features and included options, new or changed versions of set components have been released. Wherever possible (after precautionary check for compatibility with present equipment) it is recommended that this

series be ordered for new or replacement 33 equipment (Figure 5). Combined schematic and actual wiring diagrams for this equipment are available in the single Wiring Diagram Package WDP0316. Refer to Section 574-100-201TC for set installation instructions.

A. Typing Unit

3.08 The following features and options are included as part of the basic 3300 Series Coded Set components:

- (a) Either friction or sprocket paper feed, as ordered.
- (b) A TP186790 "A" codebar, TP186783 extension clip for friction feed printers and a TP186803 extension clip for sprocket feed printers (Figure 8) provide the end-of-line (EOL) bell and automatic carriage return (ACR)-line feed options. (Refer to appropriate related sections for detailed description, installation and adjustments.) On the friction feed printers the clip provides EOL bell on the 71st character and ACR-line feed on the 72nd character. The clip on the sprocket feed printer provides EOL bell on the 71st character and ACR-line feed on the 72nd character (Figure 8). The sprocket feed printer has a maximum line length of 72 characters.

(c) Stop clips to block (disable) unwanted functions (Figure 9).

- (1) The TP186781 and TP186782 stop clips were designed to block the function levers from sensing their printer codebars.
- (2) The TP186781 function lever stop clip is a short clip and is used in the related function box numbered slot. That is, the clip is placed over the slot of the codebar basket tie bar which is in direct line with the numbered function box slot. The TP186782 function lever stop clip is a long clip and is placed over the related letter slots of the codebar basket (Figure 9).
- (3) To enable automatic carriage return-line feed in a friction feed type unit, a stop clip is not provided over slot "A". When the function is to be disabled the stop clip is placed over slot "A" of the codebar basket.
- (4) To inactivate the automatic carriage return-line feed functions in a sprocket feed typing unit, a TP186872 stop clip is placed over the related slot "A" and also slot "L" of the codebar basket tie bar. The function lever in slot "A"

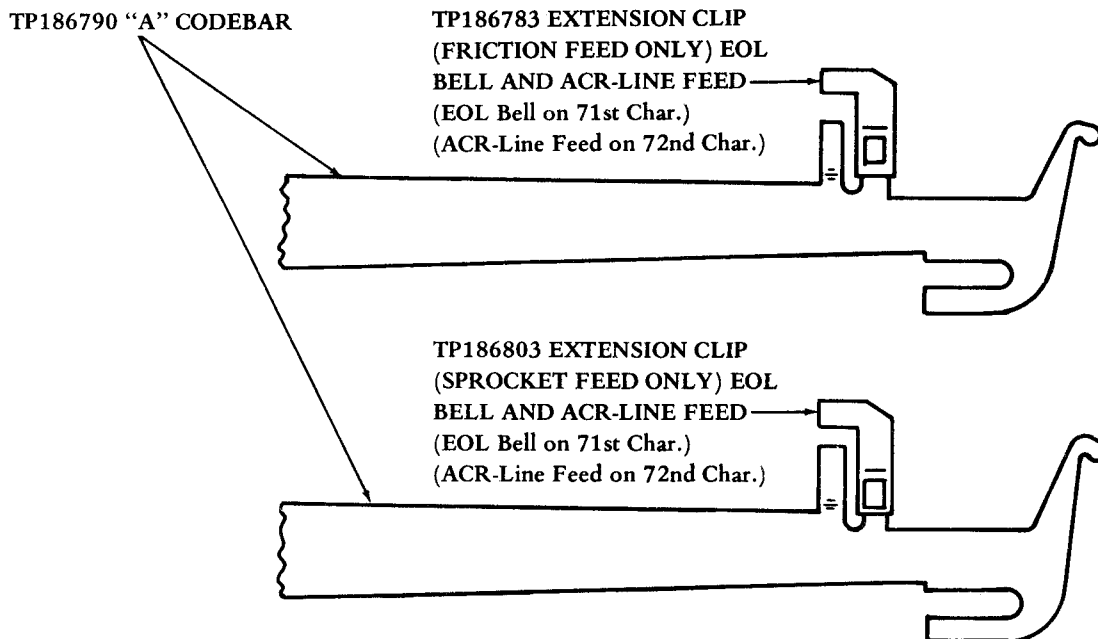
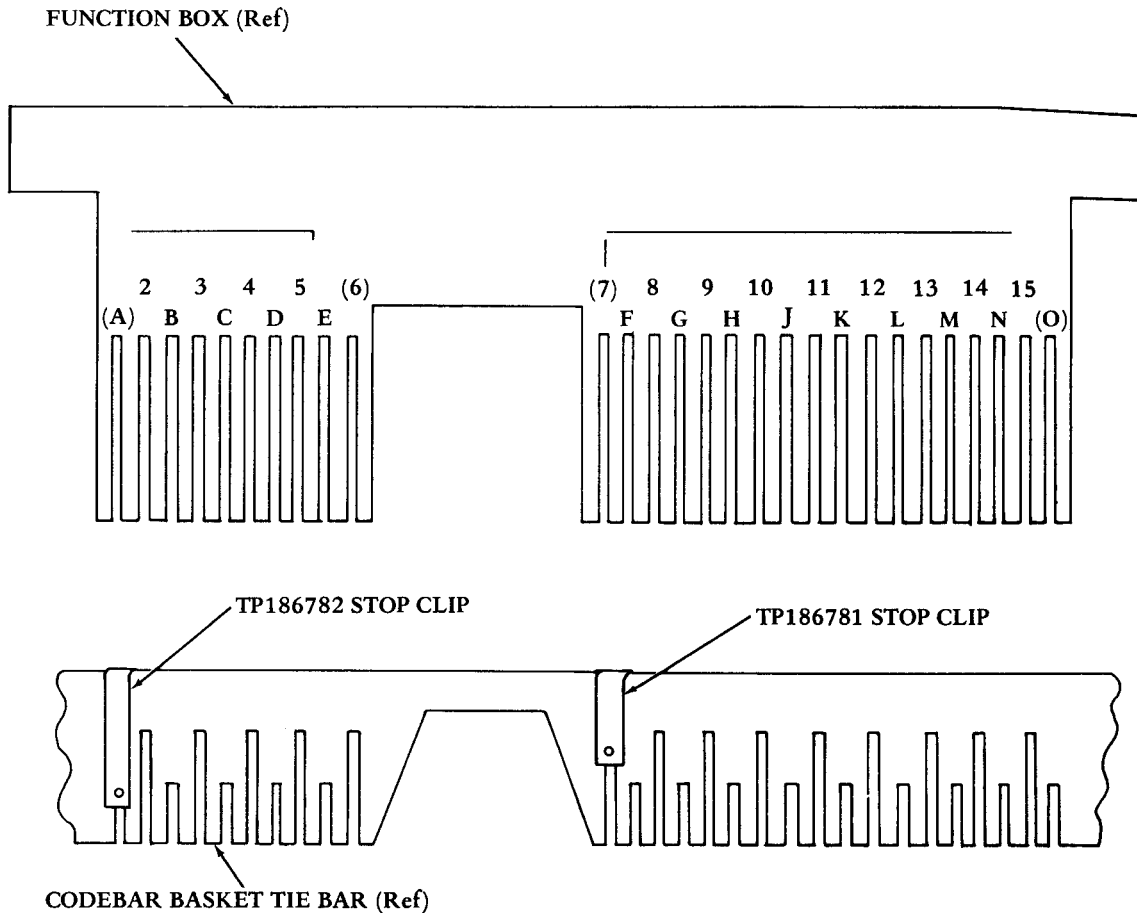

Figure 8 - Codebar With End-of-Line (EOL) Bell and Automatic Carriage Return (ACR)-Line Feed Extension Clips for 3300 Series Coded Sets



Note: Characters and numbers in () are not moulded in function box casting.

INSTALLATION OF FUNCTION LEVER STOP CLIPS

Figure 9 - Stop Clips to Block Unwanted Functions

performs the automatic carriage return function and the function lever in slot "L" performs the automatic line feed function.

(5) To activate the two functions for ACR-LF in sprocket feed units, the stop clips are removed.

Note: The TP186781 or TP186782 stop clips cannot be used on typing units incorporating the print nonprint feature using the TP183565, TP183566 and TP183567 blocking bars in their codebar baskets.

(6) To enable the margin bell and end-of-line bell, a function lever stop clip is not provided in slot "F" of the codebar basket.

(7) To disable the margin bell and end-of-line bell a function lever stop clip is placed over slot "F" of the codebar basket.

(8) If margin bell is required and no automatic carriage return-line feed and end-of-line bell is required, the TP186783 "A" codebar extension for friction feed units or TP186803 extension clip for sprocket feed units is removed. When end-of-line bell is a requirement, the margin bell is also a requirement. Both functions are operated from the same function lever.

Note: The stop clips may be used to block other function levers located in the right side of the codebar basket. The stop clips, if removed, should not be reused. A new clip should be installed.

(d) Stop plate for ASR sets without tape reader trip magnet option and for KSR and ASR sets without answer-back trip magnet option (Figure 10):

- (1) The TP186873 stop plate is intended for use in the transmitter distributor and answer-back trip magnet area.
- (2) The stop plate provides an optional feature for selection of three different voltage type magnets for transmitter distributor or answer-back trip operation. To select and add one of the three magnets for transmitter distributor or answer-back trip feature, their associated armature, armature extension, and hardware must also be added.
- (3) The function of the stop plate prevents the TP183098 clutch trip lever or the TP180843 answer-back trip lever from operating when either the transmitter distributor trip or answer-back magnets and associated armature parts are absent.
- (4) The TP186873 stop plate is installed in either the transmitter distributor trip lever magnet position or answer-back position or both (Figure 10).

B. Call Control Unit (Figure 5)

3.09 An already established 8-level, call control unit in the 3300 Series Coded Sets performs the basic functions of connecting the printer, keyboard, and reader for use on private line types of dc signal line loops. This unit incorporates the following features:

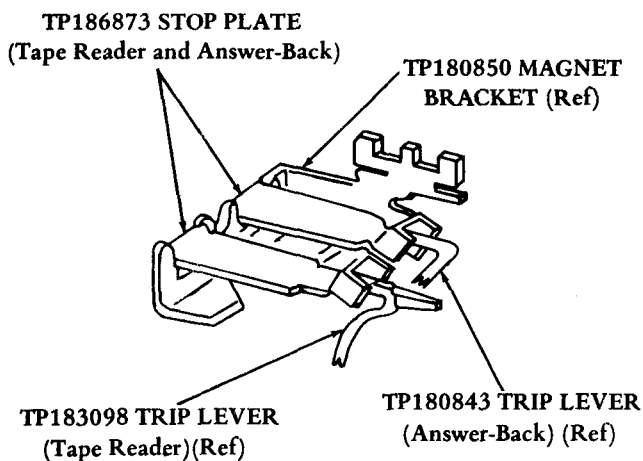

Figure 10 - Stop Plate for Tape Reader and Answer-Back Trip Levers of 3300 Series Coded Sets

- (a) Self-contained power supply to provide local battery for off-line functions
- (b) Local-line power switch
- (c) Selector magnet driver assembly capable of either 0.020 amp or 0.060 amp neutral operation
- (d) Convenience outlet
- (e) Fuses
- (f) Provisions for mounting additional components
- (g) Signal line filter
- (h) Wiring provisions for full duplex operation
- (i) Wiring provisions for parallel input and output.

The manual control knob (Figure 11) for the line-local power switch is located at the front of this unit. (Additional call control unit information is available in Section 574-123-100TC.)

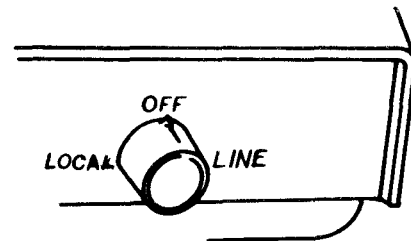

Figure 11 - Set Control Knob

C. Keyboard (Figures 5 and 6)

3.10 This keyboard is wired at the factory for even parity which the customer may optionally rewire for 8th bit always marking or always spacing (no parity). Refer to Wiring Diagram Package WDP0316. The keyboard also introduces a keytop arrangement that is compatible with the ASCII, and a matching typewheel (Figure 6).

D. Tape Punch (Figures 5 and 12)

3.11 The tape punch for 3300 Series Coded Sets incorporates the customer activated option of automatic operation. The automatic option is activated by removal of the two factory installed TP187001 disabling clips (Figure 12) from slots A-0 and A-8. The manual controls are not disabled and may still be used for operation or to override the automatic functions if desired. The automatic

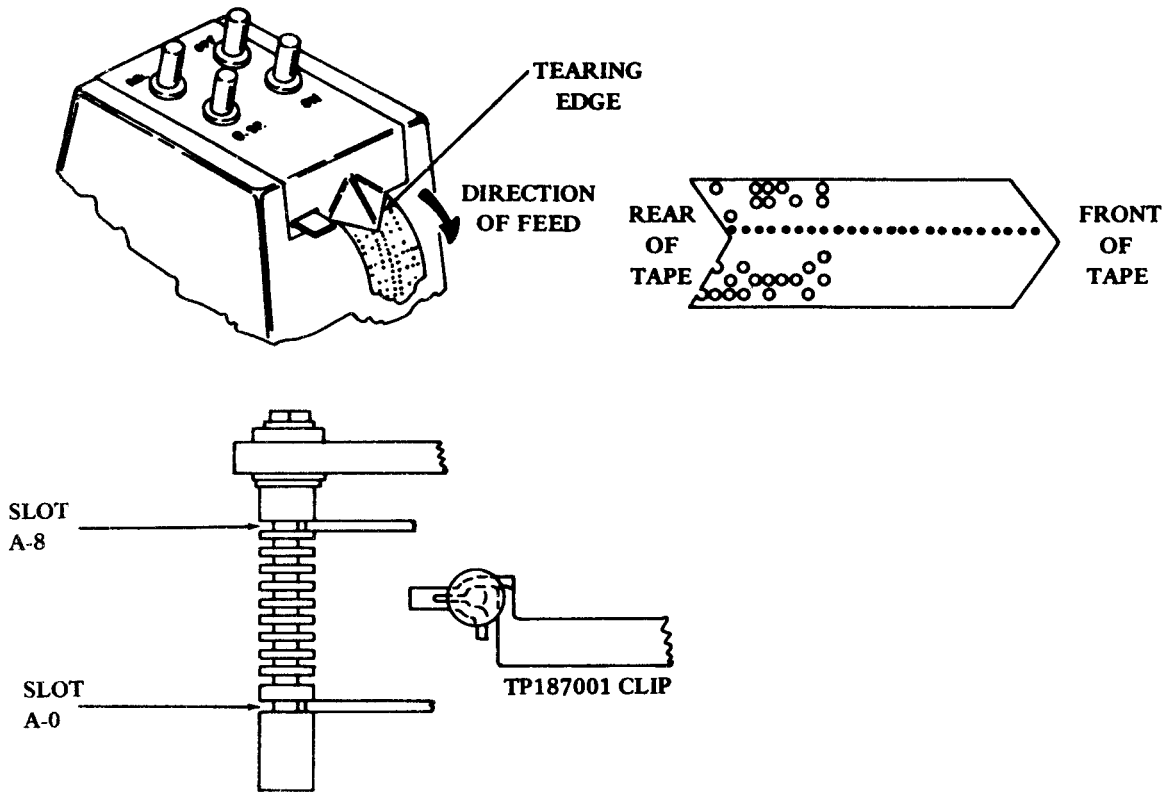

Figure 12 - Model 33 Auto/Manual Tape Punch for 3300 Series Coded Sets

functions may be disabled by reinstalling the clips. (Refer to Section 574-125-100TC for more detailed description and to Section 574-100-201TC for installation instructions.)

E. Tape Reader (Figures 5 and 13)

3.12 There is a choice of either a manual or an automatic/manual tape reader for the 3300 Series Coded Sets (Figure 13). The power pack that was formerly located outside of an ASR set is now located in the call control unit as shipped from the factory (Figure 5). If desired, this power pack may still be moved out of the set in order to install other special equipment. Operation and controls of these tape readers are as follows:

(a) Manual Operation:

START – Reader will run in this position until turned off, end of tape is reached, or the tight tape switch is operated.

STOP – Reader is inoperative in this position.

FREE – Disengages tape feed mechanism. Allows operator to pull tape through the reader for positioning.

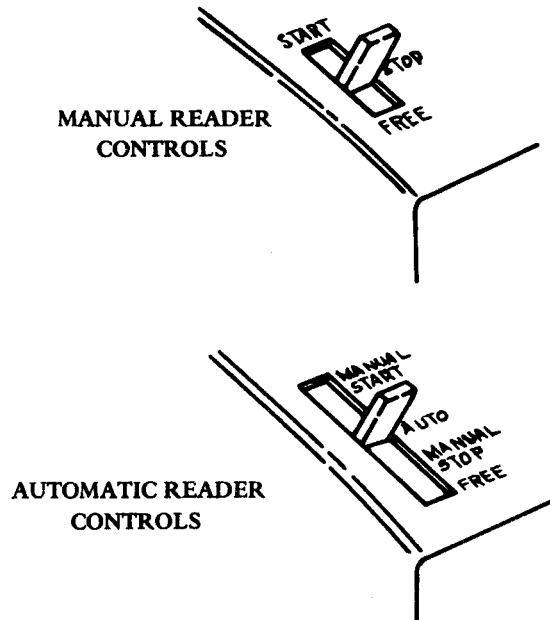

Figure 13 - Choice of Model 33 Tape Readers for 3300 Series Coded Sets

(b) Automatic Operation:

AUTO – (Automatic mode) spring biased handle is normally in automatic position, so automatic mode is assumed unless operator intervenes. The reader will respond to ASCII controls as follows:

DC1 – Automatically turns reader on.

DC3 – Automatically turns reader off.

ENQ – Stops reader and calls in answer-back. If DC1 is received at the end of the answer-back transmission, the interrupted reader will automatically restart.

MANUAL START – To activate reader without receiving the signal code DC1, the operator moves handle to MANUAL START position. Reader will then operate, with switch returning to AUTO position when released.

MANUAL STOP – To stop the reader, the handle is moved to MANUAL STOP position. Handle will return to AUTO when released.

FREE – Allows tape to be moved manually, for repositioning. Switch must be returned manually from this position to AUTO.

Control Characters – Two delete characters must follow each control character in paper tape.

TIGHT-TAPE Switch – When the tape becomes tight or tangled, the TIGHT-TAPE switch turns off the reader and thus prevents tearing the tape.

TAPE-OUT Switch – When the end of a tape is sensed, the TAPE-OUT switch turns reader off automatically. Makes it possible to turn the reader on and walk away without fear of needless reader operation.

COMPUTER INPUT-OUTPUT (I/O) SET

3.13 The following paragraphs describe significant features of the components in an I/O set (Figures 7 and 14). For schematic and actual wiring diagrams with circuit description, refer to the wiring diagram package (WDP) shipped with the equipment.

A. Typing Unit

3.14 This unit has a remote control print, nonprint solenoid (Figure 14) which suppresses printing and spacing upon command from the computer. The solenoid

leads, along with those of the distributor trip magnet, selector magnet, and low paper contacts terminate in the number five molex connector. The distributor circuitry terminates in the number two molex connector.

3.15 The typing unit prints on 8-1/2 inch wide (maximum) rolled paper. Maximum paper roll is 5 inches in diameter. Vertical spacing six lines per inch.

3.16 One color printing is provided at ten characters per inch, 72 characters per line, printing upper case alpha characters. Upper case foldover occurs for printing of upper case equivalents of lower case ASCII characters (refer to Section 574-121-100TC for description of code).

3.17 An operator adjusted single or double line feed feature is provided.

3.18 An ASCII “bell” character received, provides an audible alarm to the operator.

3.19 Automatic carriage return (CR) and line feed (LF) at the end of line after the 72nd printed character is provided. A two character buffer is required following the 72nd character if additional printing characters follow at or near 100 wpm. Otherwise, printing during carriage return will occur.

3.20 Margin bell on the 61st character and end-of-line bell on the 71st character is provided.

3.21 Low paper contacts are present on the typing unit.

3.22 No function box contacts are provided.

3.23 The motor, gear train, and fan are protected by a safety shield.

B. Call Control Unit

3.24 The I/O control unit (Figure 15) provides the electrical interconnection of the various terminal components, the interface, and control circuits. The unit consists of a circuit board, power supply, and operator control switches.

C. Keyboard

3.25 The computer input-output (I/O) 33 keyboard includes a solenoid-operated locking mechanism (Figure 14) which permits remote control of the keyboard by the computer. The locking mechanism blocks the keyboard universal lever to inhibit the distributor cycle and thus prevent any keyboarded code characters from being transmitted. The keylevers are operative in the locking mode, but the related code combinations are not stored. (See Figure 7 for a diagram of the keytop layout used on this version of the keyboard.)

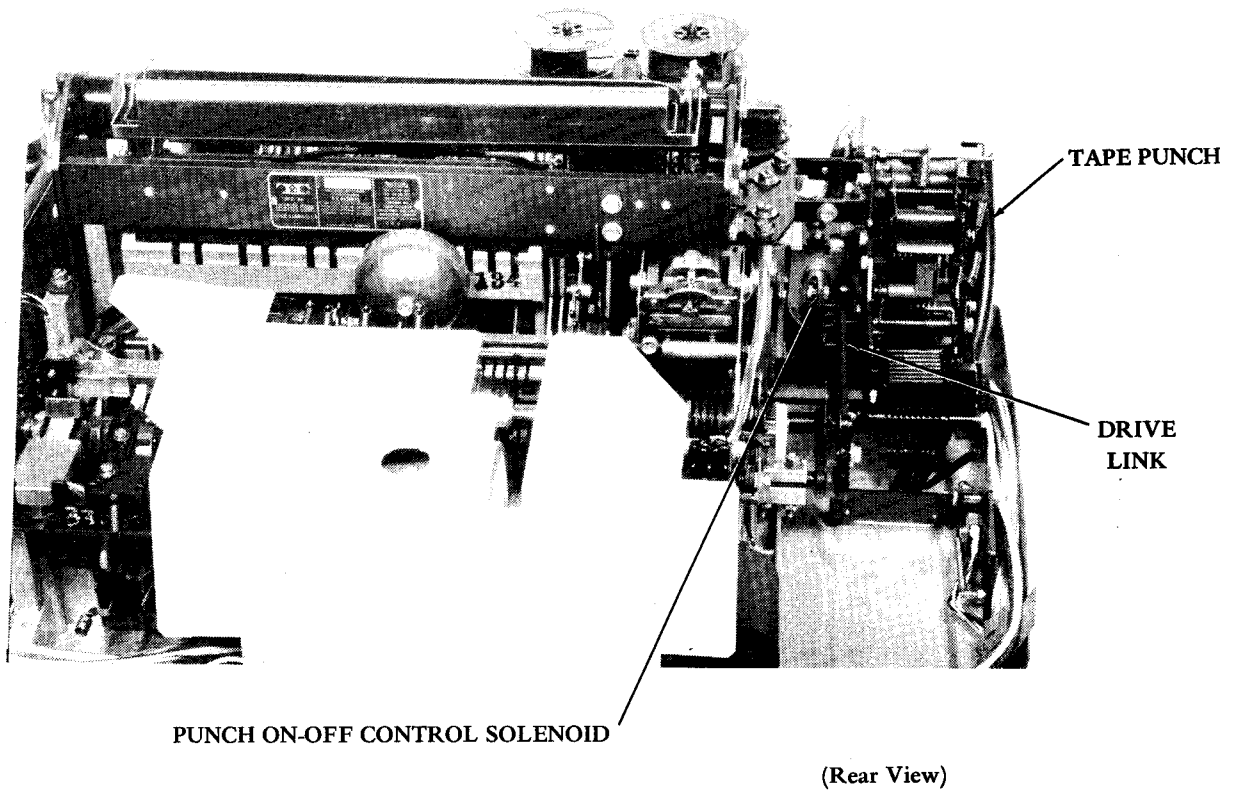
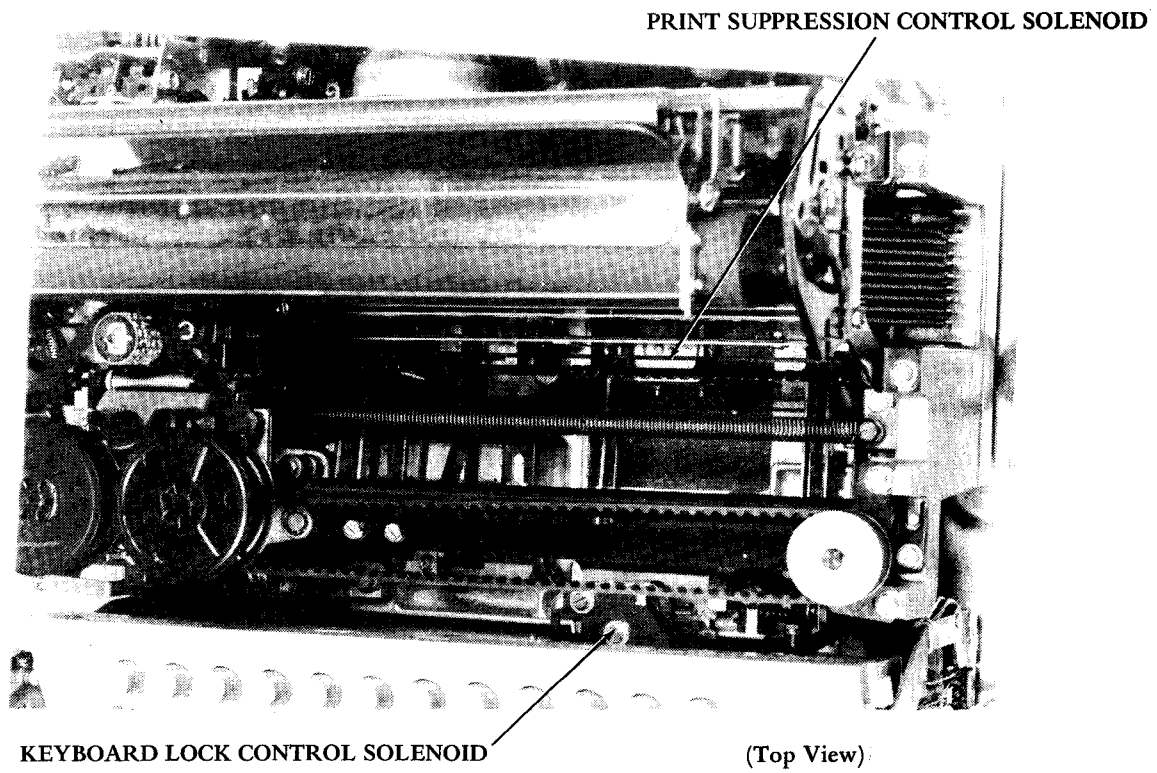
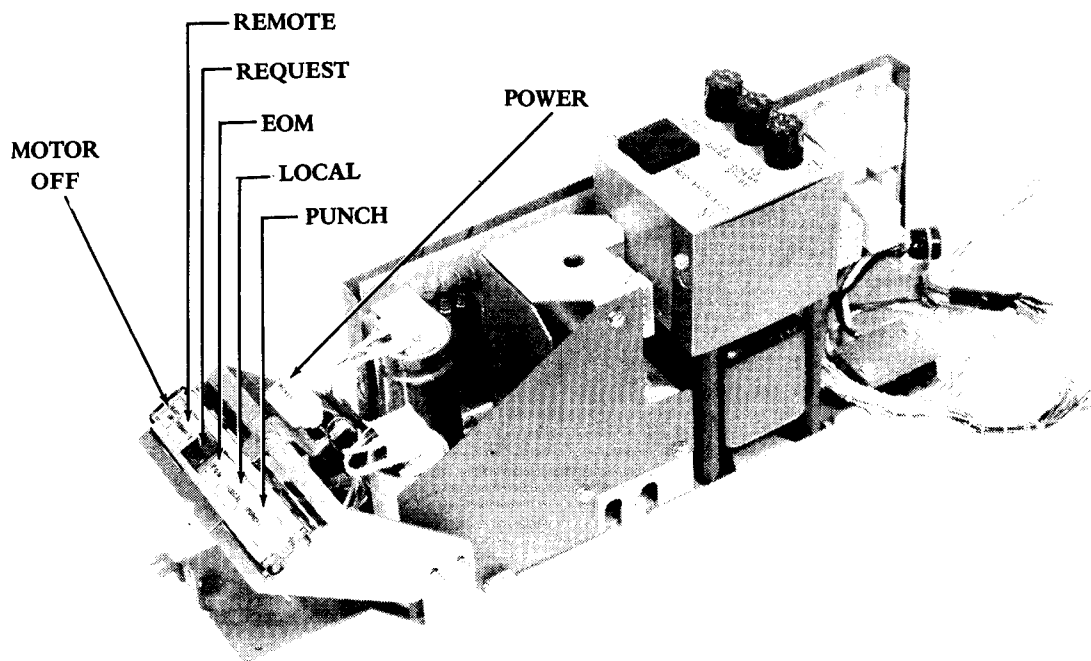

Figure 14 - Computer I/O Set Control Solenoids



COMPONENT LAYOUT AND CABLE ROUTING

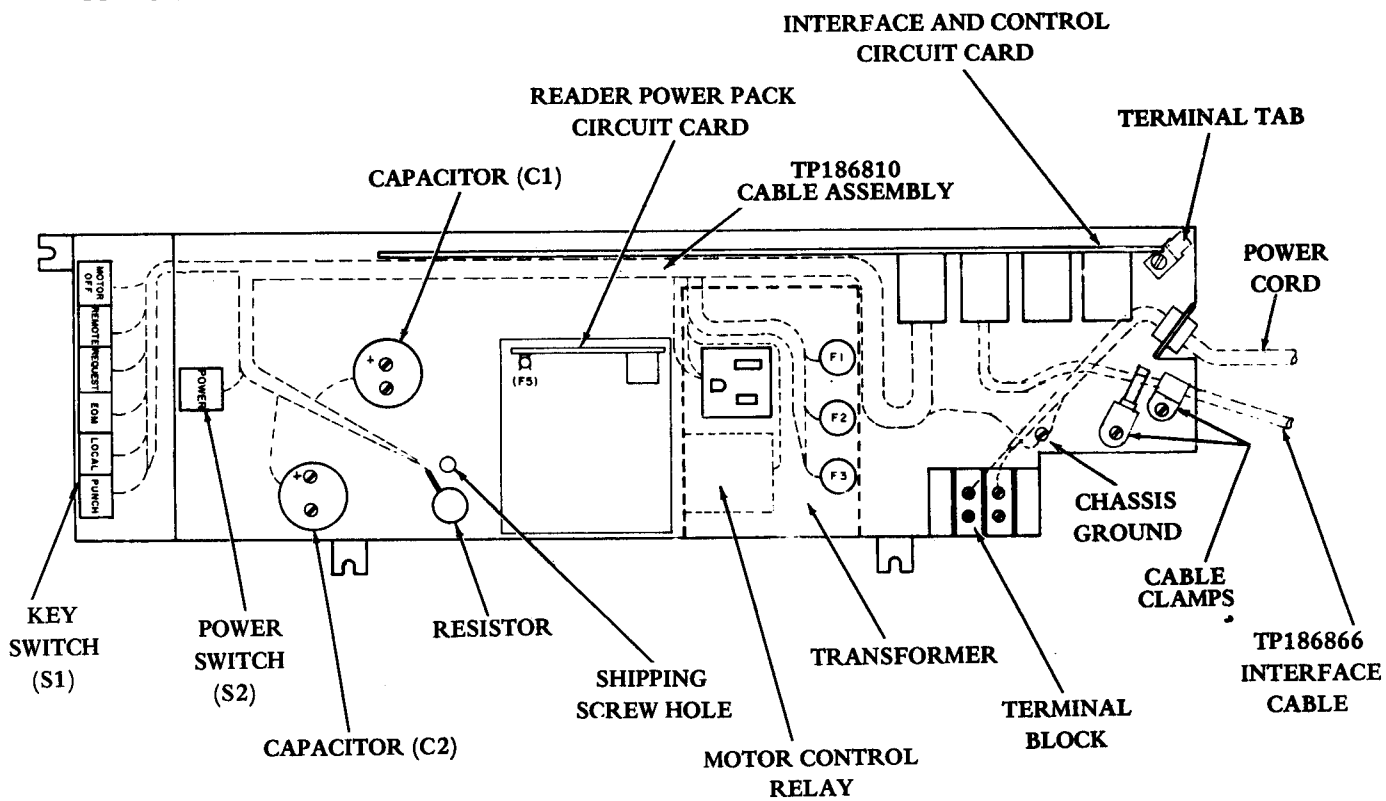

Figure 15 - I/O 33 Control Unit Removed From Set and Cable Diagram

3.26 Control is provided by the continuous duty solenoid mounted on the back of the keyboard frame (Figure 14). This solenoid is energized by a 48 v dc $\pm 10\%$ signal from the computer. When energized, the plunger is pulled into the coil, and through an operating lever, causing a camshaft assembly to rotate. As the shaft assembly rotates, the cam surface drives the universal lever of the keyboard downward, below the bottom surface of the latchlever. With the universal lever held in this position, the distributor clutch tripping mechanism in the printer is disabled.

3.27 To activate the distributor, the solenoid is de-energized by removal of the 48 v signal. The plunger is pulled out of the coil by a return spring and the mechanical linkage pivots the camshaft assembly counter-clockwise. The universal lever moves upward to the bottom surface of the latchlever, and normal distributor control action is restored.

3.28 The solenoid energization and key depression need not be synchronized in any manner. If during a key depression, the lock is energized, the lock will activate on a subsequent key depression. Conversely, if during a key depression, the lock is de-energized, the distributor will be tripped and the character transmitted.

D. Tape Punch

3.29 The I/O set 33 tape punch for remote control operation (Figures 7 and 14) differs from other 33 tape punches in that it includes a solenoid to activate the mechanism. The punch is turned on or off by an electrical signal from the computer (remote mode), or by the PUNCH ON/OFF button on the set control switch assembly (local mode). The manual ON and OFF buttons on the cover of the standard punch are not present on the remote control punch.

3.30 The solenoid mechanism is mounted at the right front of the punch. The connecting leads are routed along the left side and rear of the ASR set pan and terminate at the printer connector.

3.31 The solenoid operates at $+48\text{ v } \pm 10\%$ at a nominal current of 105 milliamperes. The "on" condition is that in which the solenoid is de-energized. The "off" condition is produced by energizing the solenoid.

E. Tape Reader

3.32 The I/O set tape reader is similar to other manual readers (Figures 7 and 13, 3.06 and 3.12) except that for remote control purposes the clutch trip circuitry and tight-tape/tape-out contact are connected to an external connector.

4. SET FEATURES

4.01 Functions – Functions refer to nonprinting operations performed by the set which are supplementary to its purpose of printing characters. All sets are equipped for the following functions.

CARRIAGE RETURN – Upon command to CARRIAGE RETURN the movable printing mechanism returns to the left margin.

LINE FEED – Advances the paper or sprocket form one or two lines.

SPACE – Every character printed is spaced a certain distance from the previous one automatically. However the set can accept a separate command to SPACE in which case it will move the printing mechanism one character space to the right.

SPACE SUPPRESSION – In some instances, such as when commands to CARRIAGE RETURN or LINE FEED are given, the set spacing mechanism is suppressed and no spacing occurs. Spacing is suppressed on all functions, except the SPACE function.

PRINT SUPPRESSION – The printing mechanism is suppressed so that no printing occurs when the set receives commands to perform any of the functions.

BLANK – The BLANK function serves to suppress printing.

4.02 Even Parity Keyboard – The '33 sets use seven intelligence pulses to accommodate the code combinations of ASCII. The remaining eighth pulse is used as an error detection device. In sets so equipped the even parity keyboard adds an eighth marking pulse whenever the number of marking pulses in a code combination is odd. If the number of marking pulses in a code combination is even, the eighth pulse is transmitted as a spacing pulse. This means that every code combination transmitted by the even parity keyboard has an even number of marking pulses.

Note: Keyboards not equipped with the even parity feature always transmit the eighth pulse as a marking pulse.

4.03 Numeric Keyboard – As the name implies, this optional feature consists of a keyboard with a numeric arrangement. It has no letters. This restricts the set for specialized applications where the exchange of data is of a numeric nature. Besides the numeric arrangement, the keyboard also transmits nonprinting functions such as EOT (end-of-transmission), SPACE, DELETE, CARRIAGE RETURN, LINE FEED, etc.

- 4.04 **Answer-Back** – In sets equipped with this feature, a mechanism coded with a predetermined sequence of characters is used for identification purposes. The mechanism may be actuated locally or remotely.
- 4.05 **Automatic Carriage Return-Line Feed** – This feature may be found on friction feed sets only; sprocket feed sets are unable to accommodate it. In sets so equipped, as printing approaches the end of the line the printing mechanism is returned to the left margin and the paper is advanced one line vertically.
- 4.06 **Sprocket-Feed** – Sprocket feed sets print characters on a sprocket fed form. Although the forms are 8-1/2 inches wide, they may be 6, 7, 8-1/2, 9, 10, or 11 inches in length. A total of 72 characters may be printed in a line on the form, with 10 characters per inch. The set will accommodate 6 lines of printed characters per inch. Varying with the weight of the carbon, the set will normally print one original and two copies. When the set has used all the forms available, an alarm will disable the set from accepting incoming calls.
- 4.07 **Form-Out (Sprocket Feed Only)** – In sets so equipped, the form-out mechanism advances the forms to a predetermined length upon command. The mechanism is adjustable to various form lengths.
- 4.08 **Paper-Out Alarm (Sprocket Feed Only)** – A set equipped with this feature will activate an alarm when the supply of forms is exhausted. The set will also refuse to accept any other incoming calls.
- 4.09 **Low Paper Alarm (Friction Feed Only)** – When the amount of paper on the roll reaches a certain amount, a switch activates an alarm which indicates to the operator that the paper supply is low.
- 4.10 **Automatic Punch Controls** – This feature allows a number of operating modes for turning the tape punch ON and OFF. The tape punch can be turned ON and OFF manually or automatically. An ON-LOCK feature which locks the tape punch in the ON mode is also available with the automatic punch.
- 4.11 **End-of-Line Bell** – Sets with this feature alert the operator that the printing mechanism is approaching the end of the line at the right margin.
- 4.12 **Print-Nonprint** – This solenoid mechanism disables a set so equipped from printing or performing functions when operated. When unoperated the set can print and execute its operations in normal fashion.
- 4.13 **Line Break** – This feature places the set so equipped in an open line condition. A BREAK key on the keyboard effects the operation.
- 4.14 **Repeat** – Sets equipped with this feature can print a character or perform a nonprinting function continuously when the REPEAT key is depressed on the keyboard together with another key.
- 4.15 **TD Call In** – An ASR set having this feature can activate the tape reader of a distant set by momentarily closing a set of contacts. The tape reader can also be activated in two other ways: By closing a set of X-On (Reader On) contacts and by manually placing the tape reader in the ON mode.
- 4.16 **Copyholder** – The feature consists of a metal frame equipped with a page indicator. The frame mounts on the back of the set, facing the operator. Messages to be transmitted may be placed on the copyholder for convenience during transmission.
- 4.17 **End-of-Transmission (EOT)** – When equipped with this feature the sending set can indicate to the receiving set that the entire message has been sent out and transmission is terminated. The keyboard has an EOT key which will activate the mechanism.
- 4.18 **Accessories** – A number of accessories are available with the set, including the following:
- (a) A sheet metal stand which supports the subbase and components at a convenient operating level. It consists of chrome feet, equipped with leveling screws or roller casters, and an enclosure to house auxiliary apparatus, such as a data set and the tape reader power pack.
 - (b) Call control facilities, including buttons, indicator lamps, motor control relay, speaker, ringer, buzzer, and rotary, TOUCH-TONE[®], or card dialers.

5. TYPICAL OPERATION AND APPLICATION

33 SET OPERATION

5.01 The following is a brief description of how 33 Teletypewriter Sets, equipped with call control and answer-back features, may be used in a typical communication system (Figure 16). When a call is to be made, an operator uses the controls on the teletypewriter set to gain access to the system switching and transmission facilities, which may be dial telephone or telegraph networks. The operator then dials the number of the called station.

5.02 The switching center selects the proper station and signals the receiving station, indicated by visual and/or audible indicators. Using the controls on the teletypewriter set, the operator at the called station completes the connection and conditions the equipment so that communi-

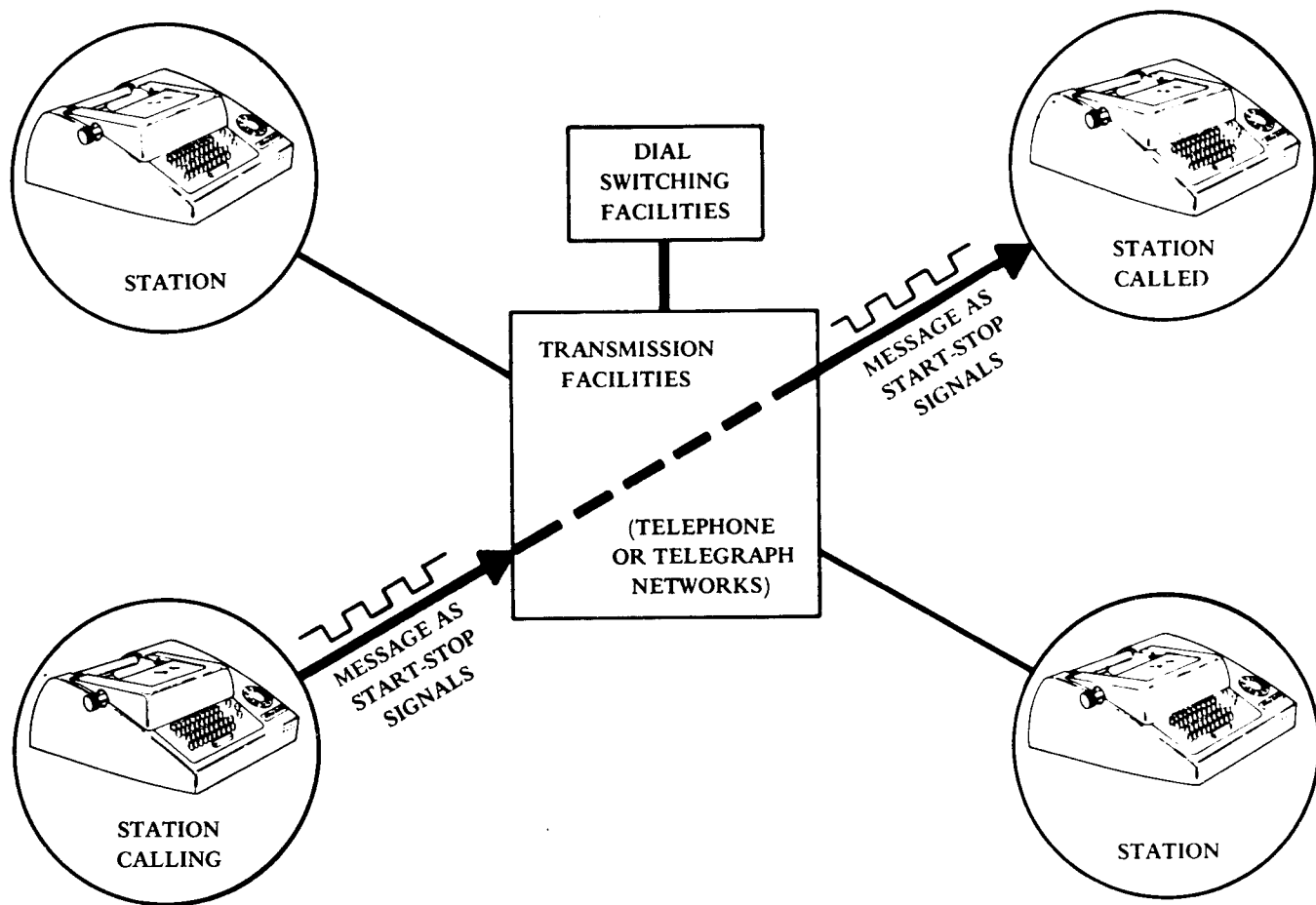

Figure 16 - Typical Applications

cation can proceed in either direction. This is indicated visually and/or audibly at the calling station.

Note: Variations of call control features provide unattended reception of calls.

5.03 Ordinarily the stations then identify themselves by the answer-back feature. The operator at the calling station can then type the message on the keyboard, or if it is an ASR set, can send it by perforated tape. In either case the teletypewriter set at the calling station translates the message to dc sequential start-stop signals which are applied to the transmission facilities. The teletypewriter sets at both the sending and receiving stations receive the signals and translate them to mechanical motions which print the message on continuous page copy or forms, and/or in the case of the ASR, perforate it in tape. If telephone networks are used, the dc start-stop signals are converted to tone frequencies for transmission and reconverted to dc start-stop signals for reception.

5.04 Finally, the operator at either station can terminate the call and return the set to its idle condition by operating the OFF control. There are a variety of OFF controls, including the EOT key on the keyboard, a control knob, or a pushbutton on the call control unit. A set may be equipped with one or two of these controls. In the case of an RO set, only one OFF control is necessary. In the case of a KSR and ASR set, the EOT control on the keyboard or the pushbutton on the call control unit may be used.

COMPUTER INPUT-OUTPUT (I/O) SET OPERATION

A. General Principles of Operation

5.05 Data is transmitted across the computer-teletypewriter link in a serial code form. The code consists of 11 elements. When a character is to be transmitted, the first element is a start pulse (always a space), followed by eight code elements which may be either marks or spaces and constitute the intelligence. The final two

elements are always both marking and are called the stop pulse. The start and stop pulses are used for synchronization purposes. Each code element takes 9.09 milliseconds, giving an aggregate rate of 10 characters per second or 110 baud. The standard code for the graphics is the ASCII. However, all 256 binary combinations may be punched, read, and transmitted from the paper tape. The information character codes for each component are as follows:

- (a) Printer – 7 level (bits) ASCII (1967) insensitive to the 8th level.
- (b) Keyboard – 7 level ASCII (1967) 8th level for even parity.
- (c) Tape Reader and Tape Punch – 7 level ASCII (1967) with even 8th level parity and – up to 8 level mark/space bit character configurations.

5.06 The recording media consists of 1 inch wide tapes for punch and reader, and 8-1/2 inch wide roll paper for the printer. Friction feed is used for printer paper transport. Seventy-two characters are accommodated per line, and ten characters per inch. Vertically, printing is on a 6 lines to the inch spacing. The I/O teletypewriter has automatic carriage return/line feed, and operates from 115 volts ac, single phase. Sets are available for either a 60 hertz supply or a 50 hertz supply.

5.07 A switch on the teletypewriter, which is described later in this section is used to select local or remote mode operation. When in remote mode, the teletypewriter communicates with the computer, and is capable of receiving serial information with the computer selecting the teletypewriter components for printing only, paper tape perforation only, or simultaneous printing and tape perforating. The teletypewriter is also capable in remote mode of sending serial information with the computer selecting the tape (reader) sender, while locking the keyboard, or permitting manual entry from the keyboard. The sending line is wrapped to the receiving line to provide local copy in the local mode.

5.08 In the local mode, the teletypewriter line outputs are wrapped to its line inputs and all data transfer functions may be tested. This will be the prime service facility for the teletypewriters. In the local mode, the teletypewriters will also be used as keypunch machines to prepare program tapes for subsequent use.

5.09 An ASCII character (bell) transmitted from the control unit to the teletypewriter activates a bell in the typing unit, providing an audible alarm to the operator.

B. Functional Features

5.10 Printers:

- (a) Friction feed, 6 lines per inch using 8-1/2 inch wide (maximum) rolled paper. Maximum paper roll diameter is 5 inches.
- (b) Adjustable single or double line feed.
- (c) One color printing (shipped with black ribbon), 10 characters per inch, upper case alpha characters.
- (d) Printers employ upper case foldover printing of 1967 ASCII lower case characters.
- (e) Automatic CR (carriage return) LF (line feed) at the end-of-line after 72nd character. A two character buffer is required following the 72nd character if additional printing characters follow at or near 100 wpm.
- (f) EOL (end-of-line) bell on 71st character; margin bell on 61st character.
- (g) Remote “print suppression” solenoid (Figure 14) operated with circuitry to external connector.
- (h) Low paper contact with circuitry to external connector.
- (i) No functional contacts in the function box.
- (j) One “TV” TP185523 typewheel.

5.11 Keyboards:

- (a) ASCII (1967) and even parity generation.
- (b) Remote “keyboard lock” solenoid (Figure 14) operated with circuitry to external connector. During the lock mode, character generating mechanism is blocked and the keylevers may be depressed.
- (c) The keyboard is supplied in one basic layout: TP184771 keytop arrangement except “line feed” instead of “new line” as shown in Figure 7.

5.12 Tape Punches:

- (a) Mechanical input from electrical printer selector mechanism.
- (b) The “punch control” solenoid (Figure 14) is operated by circuitry to the external connector. In the local mode, the punch is controlled by the operator button in the set control switch assembly.

- (c) Teletypewriter tape supply arrangement with low tape contact with circuitry to external connector.

5.13 Tape Reader:

- (a) Clutch trip circuitry wired to external connector for remote control.
- (b) Tight-tape/tape-out contact with circuitry to external connector.

C. Operator Controls

5.14 The operator controls consist of the following:

- (a) Six pushbuttons with labels:
 - (1) Motor Off (locking) (White - not illuminated)
 - (2) Remote* (locking) (illuminated, white)
 - (3) Request* (momentary, and illuminated-green)
 - (4) EOM* (End of Message) (momentary) (White - not illuminated)

*Wired to external connector.

- (5) Local (locking) (illuminated, white)
- (6) Punch (momentary push on, push off; illuminated-white when on)
- (b) Main power switch (push on, push off) controlling all primary power to the machine. Illuminated (red) when power is on.

Note: Tape reader's operating level must be in run position, tape properly positioned, and tape lid closed for remote control operation.

D. On-Line Output

5.15 In the remote mode, the teletypewriter will output serial information to the computer by two methods:

- (a) Paper Tape Entry
 - (1) Operator places the message tape in the reader, securing the tape lid and positioning the reader control level to run.

Note: By placing the tape and securing the lid, the tape-out contact is closed and through its circuitry to the external connector the computer is informed that the tape reader is ready.

- (2) Operator depresses the REMOTE key of the control keyset.
- (3) Operator then depresses the REQUEST key initiating a bid to the computer.
- (4) The computer will remotely operate the motor control relay starting the motor.

Note: The computer must pause for at least one second for motor start-up.

- (5) The computer will then remotely activate the reader and receive the message.
- (6) The motor should be stopped following the end of the read sequence.

(b) Manual Keyboard Entry:

- (1) Operator depresses the REMOTE key, then the REQUEST key of the control keyset.
- (2) The computer will remotely operate the motor control relay starting the motor.

Note: The computer must pause for at least one second for motor start-up.

- (3) The computer will then remotely activate the REQUEST lamp of the control keyset, unlocking the keyboard and permit the operator keyboard entry. At the completion of the message, the operator will depress the EOM key thereby directly indicating to the computer that message transmission is completed.
- (4) The motor should be stopped following the end of the keyboard entry sequence.

E. On-Line Input

5.16 In the on-line mode the teletypewriter will record serial information input from the computer as follows: With the control keyset selected to remote mode control, the computer can initiate a teletypewriter motor on condition after testing the low tape/low paper indication circuitry. The computer can select the method of recording, such as:

- (a) Page copy only by directly suppressing punching.
- (b) Punch tape only by directly suppressing printing.
- (c) Page copy and paper tape.

Note: The timing rules described in Figures 17 and 18 must be adhered to during the above.

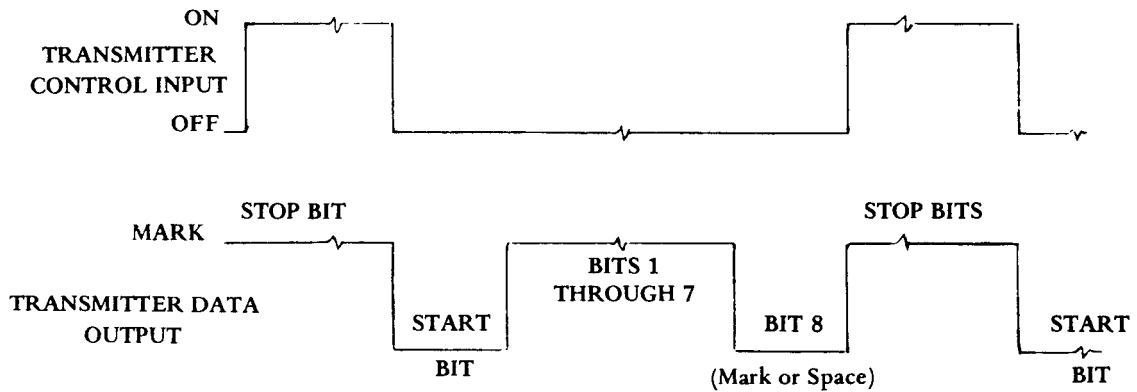

Figure 17 - Control Signal Format for Computer I/O Set
Tape Reader and Keyboard Transmitter

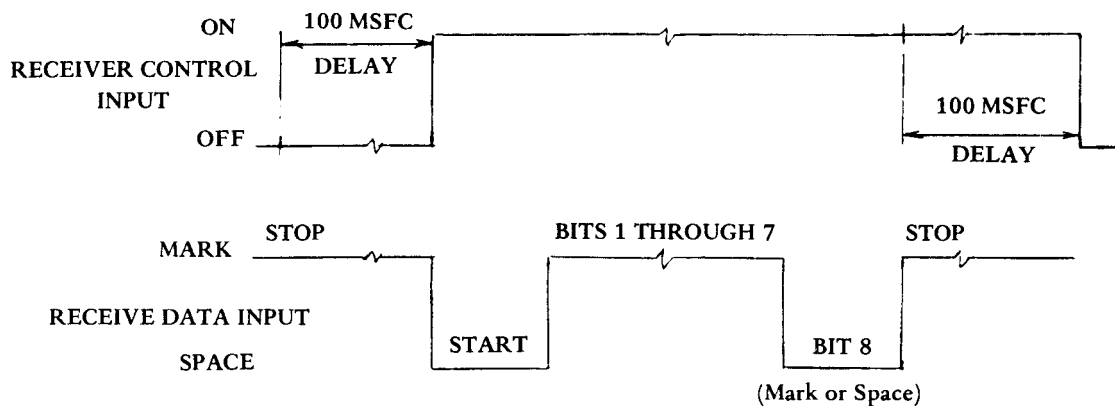

Figure 18 - Control Signal Format for Computer I/O Set
Tape Punch and Page Printer Receivers

F. Off-Line Operation

5.17 With the control keyset selected to local mode control, the teletypewriter motor is turned on. The operator can prepare message tapes from the keyboard with simultaneous page copy. Tapes can be edited by reading the tapes while recording on-page copy.

Note: The teletypewriter is arranged with all the basic component units contained within a subbase and the equipment cover. The customer must provide access for the chad container and tape loop of table mounted sets. A label affixed to the rear of the teletypewriter base gives the code and serial number.

6. TECHNICAL DATA

CAUTION: THIS EQUIPMENT IS INTENDED TO BE OPERATED IN A ROOM ENVIRONMENT WITHIN THE TEMPERATURE RANGE OF 40°F TO 110°F. SERIOUS DAMAGE TO IT COULD RESULT IF THIS RANGE IS EXCEEDED. IN THIS CONNECTION, PARTICULAR CAUTION SHOULD BE EXERCISED IN USING ACOUSTICAL OR OTHER ENCLOSURES.

33 SETS

6.01 Except where indicated otherwise for the I/O set (6.06 thru 6.33), the following applies to the 33 line of equipment:

- 6.02 Speed: 100 words per minute
600 operations per minute
- 6.03 Transmission Code: 8 level start-stop signals with
11 unit transmission pattern.
- 6.04 Dimensions and Weights (Approximate)
 - (a) RO Set
 - Width18-5/8 inches
 - Depth18-1/2 inches
 - Height8-3/8 inches
 - Weight39 pounds
 - (b) KSR Set
 - Width18-5/8 inches
 - Depth18-1/2 inches
 - Height8-3/8 inches
 - Weight40 pounds
 - (c) ASR Set
 - Width22 inches
 - Depth18-1/2 inches
 - Height8-3/8 inches
 - Weight44 pounds
 - (d) Stand
 - Width17-3/4 inches
 - Height24-1/2 inches
 - Depth (at top of enclosure)6-1/2 inches
 - Length of Feet17-3/4 inches
 - Weight12 pounds
- 6.05 Electrical Requirements:
 - Power Requirements: 115 volts ac $\pm 10\%$ 60 (or 50)
hertz ± 0.45 hertz, single phase
 - Signal Line Current: 0.020 or 0.060 ampere
 - Nominal Input to Selector: 0.500 ampere at 20 volts dc
 - Operating Margins:
 - All signal contacts and distributor:
 - Long Telegraph Loops: 0.015 to 0.070 ampere at 48 to
240 volts dc inductive
 - Short Telegraph Loops: 0.058 to 0.072 ampere at
16 to 22 volts dc resistive

COMPUTER I/O SET

A. Physical Characteristics

- 6.06 The overall set dimensions are 22-1/4 inches wide
by 20 inches deep by 8-1/2 inches high. The weight
of the set is 35 lbs. A 10-foot power cord is provided for 60
hertz sets and a 2-foot power cord is provided for 50 hertz
sets. The computer interface cable is 2-feet in length.
- 6.07 Keyboard: The keyboard includes the TP186854
modification kit to add universal keyboard lock.
- 6.08 A low tape switch operates when the tape supply is
down to approximately 1/8 inch of tape on the
tape core periphery.
- 6.09 The I/O set control unit provides the electrical
interconnection of the various terminal compon-
ents, the interface, and control circuits. The unit consists of a
circuit board, power supply, and operator control switches.

- 6.10 Safety Features: Service area voltages greater than
30 v ac and 60 v dc are shielded. Thermally hot
components in the service area are also covered. Rotating
gears and fans have shields which do not support combustion.

B. Input Power

- 6.11 The sets require a power source of 115 v ac $\pm 10\%$
at 50 or 60 hertz, ± 0.75 hertz. Running current is
less than 4 amps and starting surge is 15 amps maximum.

C. Electrical Characteristics

- 6.12 The teletypewriter 2-foot computer cable is ter-
minated with a 20-pin connector.
- 6.13 The computer to teletypewriter interface signals
are (Figure 19):

- (a) From Computer: The teletypewriter responds to
five control inputs (motor off, keyboard off,
reader off, printer off, punch off), and a data input
(receive data). The interface requirement for all six
inputs is identical. An impedance of 125 ohms or less to
computer ground is recognized as "off control input" or
a space data input, where the current which must be
sunk from the teletypewriter will cause less than 1.5
volts to appear across the 125 ohm impedance. An
impedance greater than 50,000 ohms is recognized as an
"on" control input or a "mark" data input, where a
minimum of 3.5 volts and a maximum of 7.0 volts
appears across the interface from the teletypewriter.
The most negative voltage ever to appear on the
interface is -0.5 volts.

	INPUT				OUTPUT			
	TTY On State		TTY Off State		TTY On State		TTY Off State	
	Max (Mark)	Least	Max (Space)	Least	Max (Mark)	Least	Max (Space)	Least
	+7.0 V	+3.5 V	+1.5 V	-0.5 V	+7.0 V	+3.5 V	+1.0 V	-0.5 V
Computer Impedance to Ground (ohms)	R > 50K		R < 125		450 < R < 550		450 < R < 550	

Legend: Greater > Lesser, Lesser < Greater

Figure 19 - Voltages and Impedances of I/O Set Data and Control Leads

(b) To Computer: The teletypewriter provides six control outputs (punch available, printer available, reader available, request, EOM, and remote) and a data output (send data). The interface requirement for all seven outputs is identical. An available, request, EOM or remote (control output) or a mark on the data output is effected by the application, to a computer load to ground of 500 ohms +5 percent, of from +3.5 to +7.0 volts for the TTY "On" state, or from -0.5 to +1.0 volts for the TTY "Off" state (Figure 19).

6.14 DC ground is isolated from frame ground within the teletypewriter.

D. Interface

6.15 A 20-pin connector is used for connection to the computer. The pin assignment is as follows:

A	Send Data (Out)	P	Punch Off
B	Receive Data (In)	R	Printer Available
C	Remote	T	Reader Available
F	Circuit Common	U	Motor Off
H	Reader Off	W	Keyboard Off
J	E.O.M.	D	Spare Terminal
K	Spare Wire	E	Spare Terminal
L	Request	S	Spare Terminal
M	Printer Off	V	Spare Terminal
N	Punch Available	X	Spare Terminal

E. Voltages and Impedances of Data and Control Leads

6.16 Refer to Figure 19 for both data and control lead voltages and impedances. Refer to separate wiring diagram package as shipped with equipment for all wiring diagrams and detailed circuit descriptions.

F. Data Leads

6.17 Data is transferred across the interface in a serial form. Each character consists of 11 elements, 9.09 msec. in length. Synchronization is achieved by using a two-element STOP bit (always marking) and a one element START bit (always spacing). Information is transferred by means of the remaining eight elements.

6.18 The circuit common (dc ground) is isolated from the frame ground within the teletypewriter.

Note: The following paragraphs outline the control signal format required by the teletypewriter.

G. Transmitter Control Signal Format for Tape Reader and Keyboard

Note: Refer to Figure 17 for input-output timing diagram.

6.19 In the idle state, the transmitter control signal is on the off state (control lead at ground). With its control signal off, a transmitter is disabled.

6.20 At any time, the computer may enable either transmitter (tape reader or keyboard) by switching the appropriate transmitter control (reader or keyboard) to the on (control lead HIGH) state.

6.21 Following the transmitter on command by some interval determined by the tape reader start-up time or the combination of the keyboard start-up delay and the time of keylever depression, the transmitter will respond to the on command by generating the START bit associated with the first character to be transmitted.

6.22 On recognition of the START bit the computer restores the transmitter control signal to the off state. The transmitter, having been started however, will not be affected by the off condition, continuing through the normal character cycle.

6.23 At the 8th information bit, the computer must decide whether it wishes transmission to stop or to continue. If transmission is to continue, the computer restores the transmitter control signal to the on condition and the cycle (beginning at 6.21) is repeated. If transmission is not to be continued the computer holds the control signal off and transmission will be terminated (ie, the transmitter output will remain marking).

H. Receiver Control Signal Format for Tape Punch and Page Printer

Note: Refer to Figure 18 for control and data input timing diagram.

6.24 In the idle state, the receiver control signal is in the off state (control lead at ground). With its control signal off, a receiver is disabled and will ignore any data input.

6.25 At any time, the computer may enable either receiver (or both) by switching the appropriate receiver control input (punch or printer) to the on (control lead HIGH). The switch to the on state must however be preceded by a 100 millisecond period during which the receiver data input is held marking (ie, off).

6.26 Following the shift of the control input to the ON state, data transmission can begin immediately.

6.27 At the end of the 8th information bit, the computer must decide whether it wishes a receiver to operate or to stop. If the receiver is to stop, the computer must switch the control signal to the off state. The switch to the off state must be followed by a 100 msec. period during which the receiver data input is held marking.

I. Motor Control

6.28 An on condition of the motor off lead must precede data (send or receive) by a minimum of one second. Continuously recurring motor on and off commands at short intervals may cause fuse failure due to surge current overheating. Overheating of the fuse can be alleviated by a one minute off interval.

J. Operating Modes

6.29 Depression of the power switch closes both sides of the power line activating both the 48 v dc and 24 v dc power supplies. This also activates the interface leads.

6.30 Depression of the LOCAL button causes the tape reader and keyboard output to be connected to the printer and punch. A PUNCH ON/OFF button is provided at the call control. A STOP-START-FREE switch provides manual reader control.

6.31 Depression of the REMOTE button (assuming connection to an active computer) causes the set to be in a full-duplex configuration. The tape reader and keyboard are capable of transferring data to the interface (send data) and the printer and punch will be capable of recording data from the interface (receive data). In remote, the computer will have complete control of each sending and receiving device.

K. Environmental Tolerances

6.32 The teletypewriter will operate under worstcase conditions within a temperature range of 40°F and 110°F, a relative humidity of 2 percent to 95 percent with the room air velocity between 5 and 55 feet per minute. Altitudes may vary from sea level to 10,000 feet.

6.33 Storage temperatures may range from minus (-) 40°F to 150°F with altitudes up to 50,000 feet.

7. VARIABLE FEATURES AND ACCESSORIES

7.01 The following features may be ordered for some sets and components in the Model 33 line of equipment. (Refer to Part 3 of this section and to the related parts sections.)

- (a) Elapsed Time Indicator: This item is for use only on special Model 33 sets used for switched network service, 60 hertz printer sets containing a UCC3 or UCC4 call control unit.
- (b) Intermediate Tape Storage Bin: This is for general use on ASR sets.
- (c) Tape Guide for Folded Tape: For use on ASR sets.
- (d) Mobility Casters: A set of casters for teletypewriter set.
- (e) End-of-Line Bell Feature: Parts to provide typing unit with end-of-line bell 9 characters before the end of a 69 character line.
- (f) Paper Supply Bin and Accumulating Shelf: For use on cabinets.
- (g) Twelve (12) Spaces Per Inch Conversion Parts: For use on typing units.

- (h) **Manual Single or Double Line Feed Parts:** Adds this feature to friction feed typing units not so equipped.
- (i) **Print Nonprint Mechanism:** Provides this feature for ASR set typing units not so equipped.
- (j) **Perforator Interlock Mechanism:** Provides this feature for ASR sets equipped with the UPE802 perforator and the print nonprint mechanism (see (i)).
- (k) **Dry Tape Perforator Operation Sets of Parts:** Permits oiled tape reperfors to be operated with dry (unoiled) tape.
- (l) **Directory Holder:** For use on ASR and KSR set cabinets.
- (m) **Keyboard Locking Mechanism:** Provides keyboard locking for units not so equipped.
- (n) **Automatic Carriage Return and Line Feed Mechanisms:** Provides this feature for friction feed printers not so equipped. (The 3300 Series Coded Sets and some sprocket feed printers are factory equipped with this feature.)
- (o) **Sprocket Feed 6 to 3 Line Conversion Parts:** Converts the form feed rate from 6 to 3 lines per main shaft rotation.

33 TELETYPEWRITER SETS

CIRCUIT DESCRIPTIONS

CONTENTS	PAGE	CONTENTS	PAGE
1. GENERAL	2	EOT DISCONNECT CIRCUITS	11
2. SWITCHED NETWORK SERVICE	2	RINGER AND OFF-HOOK CIRCUITS	11
TEST CIRCUIT	2	OUT OF SERVICE CIRCUIT	12
BREAK RELEASE CIRCUIT	2	PAPER ALARM CIRCUIT	12
RESTRAIN CIRCUIT	3	POWER CIRCUITS	13
CLEAR KEY CIRCUIT	3	3. CIRCUIT SWITCHING SERVICE	13
ANSWER CIRCUITS	3	POWER SUPPLY CIRCUIT	13
A. Automatic Answer	3	LOCAL-REMOTE CONTROL CIRCUITS	13
B. Manual Answer	3	A. Proceed-to-Dial Circuit	14
ORIGINATE CIRCUIT	4	B. Connect Circuit	15
ROTARY DIAL OR PULSING CARD		C. Local Circuit	17
DIALER CIRCUIT	4	MOTOR DELAY TIMER CIRCUIT	17
A. On-Hook	4	SELECTOR MAGNET DRIVER CIRCUIT	19
B. Originating a Call	4	NEUTRAL SIGNALING	20
C. Answering a Call	5	A. Circuit Interconnections	20
"TOUCH-TONE"* DIALER CIRCUIT	5	B. Idle Line Condition	21
SPEAKER AMPLIFIER CIRCUIT	5	C. Initiating a Call	22
SIGNAL GENERATOR CIRCUITS	6	D. Connection	23
A. Signal Line Circuit	6	E. Disconnect	24
B. Signal Generation Circuit	7	F. Local Off-Line Operation	24
C. Control and Shift	8	POLAR ADAPTER	24
SELECTOR MAGNET DRIVER CIRCUIT	8	A. General	24
LOCAL AND MOTOR CONTROL CIRCUITS	9	B. Receiving Polar Relay	25
READER CONTROL CIRCUITS	9	C. Sending Polar Relay	26
ANSWER-BACK CIRCUITS	11	D. Connect Control Timer	26
		E. Current Amplifier	27
		F. Circuit Interconnections	28
		G. Idle Line Conditions	28

*Service mark of AT&T Company

CONTENTS	PAGE
H. Initiating a Call	28
I. Proceed-to-Dial	28
J. Dialing	29
K. Call Connection	29
L. Remote Connection	30
M. Call Disconnect	31
N. Remote Disconnect	31
O. Local Off-Line Operation	31
4. PRIVATE WIRE SERVICE	31
INTRODUCTION	31
A. Power Switch and Local Power Supply Circuits	31
B. Mode Chart	31
OFF MODE	31
A. Power Circuit	31
B. Signal Circuit	33
LOCAL MODE	33
A. Power Circuit	33
B. Signal Circuit	33
LINE MODE	33
A. Power Circuit	33
B. Signal Circuit	33
1. GENERAL	
1.01 This section explains how various circuits are electrically coupled to a teletypewriter set, to a telegraph network or, through a data set to a telephone network.	
1.02 All circuit descriptions are made with respect to specific wiring diagrams. Alpha numeric references found in parentheses are used to located major components or circuits on the wiring diagrams. An example of a alpha numeric reference is (3C4), and should be read as follows:	
(a) The number 3 designates the sheet on which the particular circuit or component is located.	
(b) The letter and number combination C4 indicates the horizontal and vertical coordinates where the component or circuit is located.	
2. SWITCHED NETWORK SERVICE	
2.01 The KSR, ASR, and RO Teletypewriter Sets used in switched network service operate in conjunction with either a 101C or 105A data set and a call control unit.	

General descriptions and operations of the call control unit or either data set can be found in the appropriate sections.

2.02 The following circuit descriptions should be used with reference to 7882WD for KSR and ASR sets and 7881WD for RO sets.

TEST CIRCUIT

2.03 Operating the TST (test) pushbutton while the set is connected to a test center permits the message sent by the test center to be recorded by the typing unit and, at the same time, turned around and sent back to the test center for analysis.

2.04 The TST pushbutton is a locking type and may be released by momentarily depressing any of the five other pushbuttons in the six pushbutton set. When operated, the normally open contacts 23 and 24 (1D4) close to complete the 10-volt circuit through the TST lamp (located under the pushbutton) to ground.

2.05 The normally closed contacts 22 and 23 open to remove the data set from ground and disable timed disconnect-on-spacing feature. This is necessary to prevent a disconnect, should a steady spacing signal be included in a test.

2.06 The normally closed contacts 19 and 20 open to remove the keyboard or transmitter signal output at the send break timer from the modulator in the data set. The normally open contacts 19 and 21 close a circuit from the demodulator to the modulator, so that demodulated signals from the test center are modulated and sent back to the test center.

BREAK-RELEASE CIRCUIT

2.07 Set connected to 101C data set: The BRK-RLS (break-release) lamp lights when the RB (receive-break) relay operates, closing the RB make contacts. This completes the circuit from 14 v ac through the BRK-RLS lamp, the RB make contacts, and the S break contacts to ground.

2.08 The RB and the S (send space) relay operate after the CLR (clear) pushbutton is depressed. The BRK-RLS lamp may flash momentarily at this time. The opening of the S break contacts will prevent the BRK-RLS lamp from remaining on during the clear sequence.

2.09 Set connected to 105A data set: The SO (send space – normally operated) relay operates when the set is turned on. The BRK-RLS lamp lights when the RR (receive break – normally released) relay operates. The RR relay closes its make contacts which complete the circuit through 14 v ac through the BRK-RLS lamp, the RR make contacts, and SO make contacts to ground.

2.10 The RR relay operates and the SO relay releases after the CLR pushbutton is depressed. The BRK-RLS lamp may flash momentarily at this time. The opening of the SO break contacts prevent the BRK-RLS lamp from remaining on during the clear sequence.

RESTRAIN CIRCUIT

2.11 The REST (restrain) lamp lights when the RS (restrain signal) relay in the data set is energized. On a "break," which originates in the data converter, the REST and BRK-RLS lamps are both lighted.

Note: This circuit is found in KSR and ASR sets only.

CLEAR KEY CIRCUIT

2.12 Set connected to 101C data set: Momentarily depressing the nonlocking CLR pushbutton closes contacts 11 and 12. This will complete the circuit to ground in the following ways:

- (a) Answer Mode: The circuit is completed through the AN (answer) make contacts.
- (b) Originate Mode: The circuit is completed through the AN break contacts and the OR (originate) make contacts.

2.13 The complete circuit path is through the contacts mentioned in 2.12 (a) or (b), CLR contacts 11 and 12, the RB (receive break) contacts, and the RB relay to -20 v dc.

2.14 When the RB relay operates, the RB make contacts provide a holding circuit for the relay to ground through the AN make or AN break contacts and the OR make contacts, depending on the mode of the set. Other RB make contacts close to complete the circuit from ground through the AN make or AN break contacts, the OR make contacts, CLR contacts 11 and 12, RB make contacts, and the S relay to -20 v dc. The S relay operates and remains energized through the holding path provided by the AN make or AN break contacts and the OR make contacts. The S make contacts close and the CLR lamp will light. A timer circuit de-energizes the S relay after 700 milliseconds, the S make contacts open, and the clear lamp will turn off.

2.15 Set connected to 105A data set: The RO (receive break) and SO (send break) relays are normally operated, as designated by the letter O in RO and O in SO. When the CLR pushbutton is momentarily depressed, contacts 11 and 12 complete the circuit from ground through the CLR contacts, the RO make contacts, and the RR relay to -20 v dc. The RR relay operates and remains energized through its holding contacts.

2.16 The RR break contacts open the circuit to the RO relay and release the relay. The RO break contacts close the circuit from ground through the CLR contacts 11

and 12, the RO break contacts, and the SR relay to -20 v dc. The SR relay operates and is held by the SR make contacts. The SR make contacts (in series with the OH make contacts) close and light the CLR lamp. A timer circuit causes the OH (off hook) relay to release and turn off the CLR lamp.

ANSWER CIRCUIT

2.17 When a set is called, an ac ringing current, sent from the central office, energizes the RU (ring up) relay. The set may then be put into the answer condition either automatically or manually.

A. Automatic Answer

2.18 With the RU relay energized, the ANS (answer) lamp is lighted by the closure of the RU make contacts, which completes the circuit from ground through the lamp to +20 v dc.

2.19 Set connected to 101C data set: With the set in the automatic answer condition, there is a circuit path from -20 v dc through the AN (answer) relay, the RU make contacts, the CY (copy) break contacts, and CP17 to ground. The AN relay is held energized by the ground applied to its make contacts. The ANS lamp remains on because of the ground applied through the series connected AN make contacts and S break contacts.

2.20 The ANS lamp goes off when the S relay operates after the CLR pushbutton is depressed, or on the end of transmission code. The opening of the S break contacts in series with the S make contacts will turn off the ANS lamp. When the S relay operates, the S break contacts place a resistor in the circuit; the S make contacts provide a path to ground through the timer. After the timing interval during the disconnect sequence, the timer causes the AN relay to release by completing the path to ground which short-circuits the relay.

2.21 Set connected to 105A data set: With the set in the automatic answer condition, there is a circuit path from +20 v dc through the OH relay, the OR break contacts, the RU make contacts, the CY break contacts, and through CP17 to ground. The OH relay operates and is held energized by the circuit path through its make contacts, the SO make contacts, and the TM (timer) break contacts to ground.

2.22 The ANS lamp turns off when the SR relay is operated by depressing the CLR pushbutton, or at the end of the transmission code. The SR break contacts in series with the OR break contacts open to turn the lamp off. The OH relay releases when the SO make contacts and the TM break contacts open during the clearing sequence.

B. Manual Answer

2.23 The automatic answer feature is disabled when any one of the following contacts in the circuit through the AN or OH relay and the RU make contacts to ground is opened.

<u>CONDITION OF SET</u>	<u>CONTACTS OPEN</u>
-------------------------	----------------------

Local, originate, or test modes	CY break
---------------------------------	----------

Low paper	Low paper switch
-----------	------------------

Out of service	Out of service
----------------	----------------

Feeding forms or tabulating	Vertical tabulation and form out
-----------------------------	----------------------------------

2.24 During the ringing interval, the RU relay operates causing the ANS lamp to flash and the ringer to sound. The RU relay releases during the silent interval. (If the set is out of service, no ringing will take place.)

2.25 The ANS pushbutton is depressed to answer a call. (If the set is feeding forms or tabulating at this time, the set will automatically answer after the operation is completed.) The ANS pushbutton is nonlocking, and its contacts 17 and 18 (1D7) close momentarily.

2.26 Set connected to 101C data set: Closure of the ANS pushbutton completes the circuit from ground through the S and OR break contacts, ANS contacts 17 and 18, and the AN relay to -20 v dc. The AN relay then operates and is held energized by the ground applied by the AN make contacts. Subsequent operation is the same as the automatic answer described in 2.19 and 2.20.

2.27 Set connected to 105A data set: Depressing the ANS pushbutton completes the circuit from ground through the SO make contacts, the ANS contacts 17 and 18, the OR break contacts, and the OH relay to +20 v dc. The OH relay operates and is held energized by the OH and SO make contacts to ground. Subsequent operation is the same as the automatic answer as described in 2.21 and 2.22.

ORIGINATE CIRCUIT

2.28 The RO set goes into the originate mode but has no amplifier.

2.29 Depressing the nonlocking ORIG (originate) pushbutton momentarily closes contacts 5 and 6 (1E7). This will start the following operations, provided the set is not in an answer condition.

2.30 Set connected to 101C data set: Depressing the ORIG pushbutton completes the circuit from ground through the S and AN break contacts, the ORIG contacts, and the OR relay to -20 v dc. The OR relay then operates and is held energized by the OR make contacts and AN break contacts to ground. The closure of the OR make contacts in series with the S break contacts turn on the ORIG lamp and makes the speaker amplifier operable by turning on output transistor Q2 (2E6).

2.31 After the CLR pushbutton is depressed, or upon receipt of the end of transmission code, the S relay operates and its break contacts (in series with the OR make contacts) open to turn off the ORIG lamp and disable the speaker amplifier. The OR relay releases during the disconnect sequence in the same manner as the AN relay releases as described in 2.20.

2.32 Set connected to 105A data set: Depressing the ORIG pushbutton completes the circuit from ground through the SO make contacts, the OH break contacts, the ORIG contacts 5 and 6, and the OR relay to +20 v dc. The OR relay then operates, its make contacts close and the OH relay will operate. The OR relay remains energized when the ORIG pushbutton contacts 5 and 6 open through the holding circuit composed of the OR, OH, and SO make contacts to ground.

2.33 The ORIG lamp lights with the closure of the OR and OH make contacts (in series with the SR break contacts). These contact closures also make the speaker amplifier operable by turning on output transistor Q2.

2.34 After the CLR pushbutton is depressed, or upon the receipt of the end of transmission code, the SR break contacts (in series with the OR and OH make contacts) open, turning off the ORIG lamp and disabling the speaker amplifier. Relays OR and OH release during the disconnect sequence in the same manner as the OH relay in 2.22.

ROTARY DIAL OR PULSING CARD DIALER CIRCUIT

2.35 The following circuit description applies to ASR and KSR sets only.

2.36 When originating or answering a call, the ringer is disconnected and the hybrid transformer is connected, between ring and tip, to present an off hook condition to the central office. Both the rotary dialer and pulsing card dialer have off-normal contacts which close and short circuit the speaker output during dialing. The operator, therefore, will not hear dialing clicks through the speaker.

A. On-Hook

2.37 When the set is in the on-hook condition, the ringer is connected between ring and tip through the AN break and OR break contacts (in the 101C data set) or, through the OH break contacts (in the 105A data set).

B. Originating a Call

2.38 Set connected to 101C data set: the OR relay operates, the OR break contacts open the ringer circuit, and the OR make contacts close the circuit from tip, through the pulsing contacts of the rotary dial (and the pulsing card dialer, if present), and through the hybrid transformer to the ring circuit.

2.39 Set connected to 105A data set: The OH relay operates and the OH break contacts open the ringer circuit. The OH make contacts close the circuit from tip, through the pulsing contacts of the rotary dial (and pulsing card dialer, if present), and through the hybrid transformer to the ring circuit. After the call connection is made, the CR (connect) make contacts or the CO (connect) break contacts close to short circuit the dialer pulsing contacts.

C. Answering a Call

2.40 Set connected to 101C data set: During an automatic answer, the RU (ring up) break contacts (2C2) open and prevent ringing current from reaching the hybrid transformer when the AN contacts close. The AN relay is operated and the AN break contacts open the ringer circuit. The AN make contacts close the circuit from tip, through the OR break contacts, the AN make contacts, the RU break contacts, and the hybrid transformer, to the ring circuit. Since the set is in an answer condition, the dialer pulsing contacts are not in the circuit.

2.41 Set connected to 105A data set: During an automatic answer, the RU (2B2) break contacts open and prevent ringing current from reaching the hybrid transformer when the OH make contacts close. The OH relay is operated and the OH break contacts open the ringer circuit. The OH make contacts close and the CR make or CO break contacts close, completing the circuit from tip through the OH make contacts, the CR make or CO break contacts, the RU break contacts, and through the hybrid transformer to the ring circuit. Since the set is in an answer condition, the dialer pulsing contacts are not in the circuit.

"TOUCH-TONE" DIALER CIRCUIT

2.42 The following circuit description applies to ASR and KSR sets only.

2.43 The tone dialer utilizes a transistor oscillator which generates two frequencies each time a pushbutton on the dialer is depressed. The frequencies of oscillation are determined by the values of inductance and capacitance in tank circuits T1-C1 and T2-C2 (3D4-3D6). Different values of L and C are placed into the tank circuits (by the closure of contacts in each circuit) when the pushbuttons are depressed.

2.44 The tone dialer is made operable only when the set is the originate mode and before the call connection between stations is made. The dialer is made operable by making the base of Q1 (3F5) negative with respect to the emitter, causing the transistor to conduct. The circuit path is from ground through the 200 ohm resistor (connected to the CAL rheostat), RV4, RV3, R1, and into the data set at CN41 to -20 v dc.

2.45 In the 101C data set, this path is provided by the CON make-break and M make-break contacts. In the 105A data set, the path is provided by the CO make-break and MO make-break contacts.

2.46 Once the stations are connected, the dialer is disabled to prevent interference caused by its accidental use. It is disabled by opening the circuit between -20 v dc and the collector of Q1. This turns off Q1 and stops the oscillations. The CON break contacts (in the 101C data set) or the CO make contacts (in the 105A data set) open to break the circuit when the stations connect.

2.47 When a tone dialer is used, the speaker amplifier receives two inputs: the normal telephone line input and a tone dialer input. The telephone line signal path is from the incoming amplifier in the data set through CN31 (in the 101C data set) or CN30 (in the 105A data set) through contacts CS (W2-V) to terminal 1 of speaker amplifier input transformer T1 (3F3). The signal from the secondary winding of T1 is fed through contacts CS (Z-Y) and capacitor C1 to the base of input transistor Q1.

2.48 The tone dialer multifrequency output is applied to the base of input transistor Q1 through capacitors C5 and C1. The speaker amplifier output (dial tone) is applied to both the speaker amplifier and the telephone line through the data set. The circuit path to the telephone line is from the emitter of output transistor Q2, through capacitor C3, contacts CS (T-S), and to the outgoing amplifier in the data set at CN47.

2.49 Depressing a pushbutton on the dialer causes common switch CS to operate and its YZ contacts (3D5) to open. This disconnects the signal input from the telephone line to the speaker amplifier. Common switch contacts ST (3D3) close to connect the amplifier output to the telephone line through the outgoing amplifier in the data set. Contacts W2-V open to prevent the dial tone from reaching the incoming amplifier which would cause a false connect. Contacts W1-U (3C6) open and interrupt the dc current in tank coils T1 and T2. Oscillations then start with a very short build-up time.

2.50 Potentiometer CAL (3E4) is used to adjust the level of multifrequency signals generated by the dialer. It must be adjusted each time the data set is changed.

2.51 Capacitor CAN (3E4) and C4 (3F5) suppress spurious signals in the range of 7 k hz to 14 k hz. These signals are generated during the short time interval when all sensing contacts and the E contacts (3B7) are open.

SPEAKER AMPLIFIER CIRCUIT

2.52 The following circuit description applies to ASR and KSR sets only.

2.53 The speaker amplifier is a conventional, direct-coupled, two-transistor audio amplifier. The amplifier may receive two inputs. One input, the frequency-modulated dial signals from the buffer amplifier in the data set limiter circuit, is fed to the primary winding of input transformer T1. (This winding continuously carries the 4 ma quiescent current of the receiving buffer amplifier in the data set). The second input comes from the tone dialer (if used), and is fed directly into the input transistor Q1 through capacitor C5. Both inputs to the speaker amplifier are dc isolated from the amplifier stages.

2.54 The output transistor, Q2, provides outputs from its collector and emitter. The output from the collector of Q2 is applied to the step-down output transformer T2, and then to the speaker and receiver. Potentiometer CF is used to set the proper volume level which may vary with loop loss and the ambient noise level. Dial tone is independent of loop noise.

2.55 The output from the emitter of Q2 is divided into two signal lines. One injects the dial tone into the data set sending amplifier. The second signal line feeds the dial tone detection circuit in the data set (if provided). Signal levels from the emitter of Q2 are essentially independent of the volume control setting.

2.56 Resistor R6, bypassed by capacitor C6, is a supply voltage dropping resistor. Diode CR1 (2E6, 3E6) blocks the sneak path from ground through the ANS and ORIG lamps in the answer mode. Without CR1, the ORIG lamp would be dimly lighted and the speaker amplifier would not be silent when the station is in the answer mode.

2.57 When operating with a 101C data set the speaker amplifier is made operable only during the originate mode. This occurs when the OR (originate) relay operates and its make contacts close, completing the circuit from the emitter of Q2, through the S (send space) break contacts (2E8, 3E8), to ground.

2.58 When operating with a 105A data set the speaker amplifier is made operable only in the originate mode. This occurs when the OR relay operates and its make contacts close, completing the circuit from the emitter of Q2, through the SR (send space) break contacts and the OH (off-hook) make contacts, to ground.

2.59 The speaker amplifier is disabled after the stations connect. This is done by short-circuiting the primary of input transformer T1 through ground by closure of the CON (connect) make contacts (in the 101C data set) or the CO (connect) break contacts (in the 105A data set).

SIGNAL GENERATOR CIRCUITS

A. Signal Line Circuit

2.60 The following circuit description mainly refers to ASR sets. It can be used with KSR sets if all references to the reader are disregarded. It can be used with

RO sets if all references to the reader and keyboard are disregarded.

2.61 The signal line circuit path is from -20 v dc in either the 101C or the 105A data set (4F3). The circuit path goes into the teletypewriter set at CP7, through the distributor, keyboard, reader contacts, and into the data set at CP8.

2.62 Set connected to 101C data set: When the signal generator contacts are closed, current of approximately 0.005 ampere flows from +20 v dc through the 7500 ohm resistor (4F7) to -20 v dc; and a current of approximately 0.008 ampere flows from ground, through the emitter and base of Q1M, to -20 v dc. The current through the contacts is the sum of these two currents, or about 0.013 ampere.

2.63 The voltage across diode CR1M (4F7) is fed to the modulator in the data set. When CR1M conducts, the modulator generates the marking frequency; when the diode is off, the modulator generates the spacing frequency.

2.64 The modulated signal is then fed to the limiter and discriminator for demodulation. Demodulated signals consist of current during marking pulses and no current during spacing pulses. During marking pulses, transistor Q3A (4F4) conducts and provides a circuit from ground through its emitter and collector, through the 249 ohm resistor into the teletypewriter set at CP1. From CP1 the circuit is through the selector magnet drivers, and into the data set at CP2 to -20 v dc.

2.65 Depression of the BREAK key for 140 milliseconds or longer is recognized as a break by the send break timer in the data set. This causes the modulator to originate a timed spacing signal of 225 milliseconds duration.

2.66 The timed spacing signal is recognized as a break (and not a disconnect) by the timer in the data set, which causes the RB (receive break) relay to pull up and close the RB make contacts (4F3). The RB make contacts shunt the transmitter and keyboard signal generator contacts which block transmission from the station. The BRK-RLS pushbutton must be depressed before transmission can be resumed.

2.67 Set connected to 105A data set: From CP8 the circuit path is through the SO or RO make contacts to the base of the modulator keying transistor 4Q3 in the data set. When the signal generator contacts are closed, the base is negative with respect to the emitter and 4Q3 is on. This causes the modulator to generate the marking frequency. When the signal generator contacts are open, transistor 4Q3 is off, and the modulator generates the spacing frequency.

2.68 In half-duplex operation, the circuit also goes into the teletypewriter set at CP2, through the selector magnet driver, into the data set at CP1, and through the discriminator output transistor 6Q10. Demodulated signals consist of current during marking pulses and no current during spacing pulses.

2.69 During marking pulses, transistor 6Q10 conducts and provides a circuit from ground through its emitter and collector, through the 240 ohm resistor, into the teletypewriter set at CP1, to and through the selector magnet drivers, into the data set at CP2, and through the signal generator contacts to -20 v dc.

2.70 The time break signal is generated in the 105A data set as follows: When the set is turned on, the CO (connect – normally operated) relay operates and the timer operates the TM (timer) relay. The TM make contacts (4F8) complete the circuit through the BO (break – normally operated) relay and the CO make contacts to ground. The BO relay operates and is held operated by its make holding contacts and break key contacts when the TM and CO relays release.

2.71 Depressing the BREAK key releases the BO relay, causing the timer in the data set to generate a timed spacing pulse (about 200 milliseconds duration). The BO break contact closes to complete the circuit from +20 v dc through the TM break contacts and BO break contacts, to the base of modulator keying transistor 4Q3. This turns 4Q3 off and causes a spacing pulse to be generated.

2.72 The TM relay operates 200 milliseconds later to interrupt the path from +20 v dc, through the TM and BO break contacts, to the base of 4Q3. The transistor turns on again, and the BO relay operates through the circuit from +20 v dc, through the TM make contacts, the BO relay, and the CY make contacts to ground. The BO relay is held operated by its make holding contacts and the break key contacts when the TM and CO relays release.

2.73 When the CY (copy) relay is released, the selector magnet drivers are held in a ready marking condition as follows.

(a) Operation with a 101C data set: The CY break contacts close to keep discriminator output transistor Q3A conducting to ground.

(b) Operation with a 105A data set: The CY break contacts close to provide a path to ground in parallel with transistor 6Q10. Other CY break contacts short-circuit the signal generator contacts to -20 v dc.

B. Signal Generation Circuit

2.74 The following circuit description mainly refers to ASR sets. It can be used with KSR sets if all references to the reader are disregarded. It can be used with

RO sets if all references to the reader and keyboard are disregarded.

2.75 Depressing a key, or operating the reader or answer-back, causes contacts to either open or close a part of the circuit path for each code pulse. The remainder of the circuit path passes through the code segment on the outer ring of the distributor, and through the brush to the inner ring.

2.76 The code pulses will be marking if the circuit path is closed, and spacing if the circuit path is open.

2.77 The path for each pulse through the answer-back contact block are make contacts. Operation of these contacts is determined by the coding of the answer-back drum.

2.78 The path for each pulse through the reader contact block are make contacts. These contacts will remain open until a hole is sensed in the tape. When this condition occurs, the contacts will momentarily close.

2.79 The paths for pulses 1, 2, 3, 4, and 6 through the keyboard contact block are make contacts. The contacts close for each pulse whenever a key is depressed that corresponds to that pulse marking.

2.80 The path for the 5th pulse is determined by transfer and shift transfer contacts. When a key is depressed for a character, the 5th pulse make contacts (4B3) close. This provides a circuit path from KP(5) or KP(2) through shift break and shift make contacts to KP(3).

2.81 When the shift key is depressed in addition to a key for a character which has the 5th pulse marking, the 5th pulse shift break contacts will open. Therefore, no circuit path is provided between KP(5) or KP(2) and KP(3), and the 5th pulse will be spacing.

2.82 When the shift key is depressed in addition to a key for a character which has the 5th pulse spacing, the 5th pulse shift make contacts will close. This will provide a circuit path from KP(5) or KP(2), through shift make and shift break contacts to KP(3), and the 5th pulse will be marking.

2.83 The path for the 7th pulse goes from KP(4) through the KP-V make contacts as follows:

(a) On a nonparity keyboard, the path continues through KP-P, the control break contacts, and KP(3) to KQ-1.

(b) On a parity keyboard, the path continues through KS(2), KS-A, the control break contacts, and KS(1) to KQ-1.

SECTION 574-100-103TC

2.84 The path for the 8th pulse, through the keyboard contact block on a nonparity keyboard, are make contacts which close so that the 8th pulse is marking for all characters.

2.85 The path for the 8th pulse, through the contact block on parity keyboards, is from KP(2) to KS(1) as follows:

(a) The 8th pulse is spacing for all characters when the sum of the marking pulses in bits 1 through 7 is even. No path is provided between KP(2) and KS(1) since the 8th pulse make contacts connected to KP-J and the shift make contacts connected to KS-C are open.

(b) The 8th pulse is marking for all characters when the sum of the marking pulses in bits 1 through 7 is odd. A path is provided from KP(2) through the 8th pulse make contacts, KP-J, KP-L, KS-D, the shift break contacts, KS(2), KS-A, and the control break contacts to KS(1).

2.86 When the CTRL (control) key is depressed along with a key for a letter character, the control break contacts open so that the 7th pulse is now spacing. This action makes the 6th and 7th pulses alike resulting in a control or nonprint character.

2.87 On a parity keyboard, whenever the SHIFT key is depressed to invert the 5th pulse, or the CTRL key is depressed to change the 7th pulse from marking to spacing, the 8th pulse must be changed to keep the sum of the marking pulses even. This is accomplished in the following manner:

(a) When the SHIFT key is depressed and the 8th pulse is normally marking, the opening of the shift break contacts connected to KS-D changes the 8th pulse to spacing.

(b) When the SHIFT key is depressed and the 8th pulse is normally spacing, the closing of the shift make contacts connected to KS(2) change the 8th pulse to marking. The circuit path is traced from KP(2) through the break contacts KP-K, KP-R, KS-C, shift make contacts, KS(2), KS-A and the control break contacts to KS(1).

(c) When the CTRL (control) key is depressed and the 8th pulse is normally marking, the opening of the control break contacts change the 8th pulse to spacing.

(d) When the CTRL key is depressed and the 8th pulse is normally spacing, the closing of the control break contacts connected to KS(2) changes the 8th pulse to marking.

C. Control and Shift

2.88 To obtain certain code combinations, the CTRL (control) and shift keys are depressed in addition to some other key. When this is done, the 5th pulse is inverted and the 7th pulse is spacing, but the 8th pulse does not change.

2.89 With the 8th pulse normally marking, the circuit goes from KS(2) through the make contacts, KP-J, KP-L, the shift make contacts, KP(6), KS-B, and the control make contacts to KS(1).

2.90 With the 8th pulse normally spacing, the circuit will be broken since the shift break contacts connected to KP-R and the 8th pulse make contacts are open. The path through KP-R, KS-C, the shift make contacts, KS(2), and KS-A is broken since the control break contacts are open.

SELECTOR MAGNET DRIVER CIRCUIT

2.91 The selector magnet driver is a two-stage triggering regenerative amplifier or flip-flop, used to drive the selector magnets of the typing unit. The input, 0.020 or 0.060 ampere signal line current, is used to switch the selector magnets 0.500 ampere output current to full on or off, without intermediate levels. This provides a switching operation similar to that obtained with relays.

2.92 Zener diode ZD1 provides a reference voltage of 4.7 volts. This voltage is maintained regardless of varying values of current through ZD1 or with variations in external voltages. Therefore, the junction of CR4 and ZD1 is always -24.7 v dc. (Current flows from -20 v dc through ZD1, CR4 and R8, and through the parallel path of R2 to -40 v dc.)

2.93 The frequency modulated space and mark signals are demodulated and amplified in the data set. Refer to the appropriate sections for a description of the data set discriminator and dc amplifier circuits.

2.94 When spacing pulses are generated, no current flow through the emitter and collector of Q3A (in the 101C data set) or 6Q10 (in the 105A data set). A current of 10 ma flows from -20 v dc through resistor R3, varistor CR5 and the emitter-base path of Q1, and through R1 to -24.7 v dc at the junction of CR4 and ZD1. (When the signal line current is 0.060 ampere and switching at 0.030 ampere is desired, R1 is 135 ohms.) Transistor Q1 is on (base is more negative than emitter) and current flows through its emitter and collector. This puts the base of Q2 at about -20 v dc. The Q2 emitter, because of bias resistor R6, is at about -20.5 v dc. Because the base of Q2 is positive with respect to the emitter, Q2 is off and no current flows through the selector magnet coils.

2.95 When marking pulses are generated, a 0.020 ampere signal current flows from ground at the emitter of transistor Q3A (in the 101C data set) or 6Q10 (in the 105A data set) through the emitter-collector path, resistor R30N or 6R44 in the data set and through resistor R10. (Resistor R10 is strapped out for operation with 0.060 ampere signal current.

2.96 The current through R10 then divides with 0.010 ampere going through resistor R1, diode CR4 and resistor R8, and through the parallel path of resistor R2 to -40 v dc. The base of Q1 is at a potential of about -19.5 v dc while the emitter is at -20 v dc. With the base more positive than its emitter, Q1 is off and has no collector current. The voltage drop across diode CR4 is about 0.5 volt, making the potential at the base of Q2 about -25.2 v dc. With the base more negative than its emitter, Q2 turns on, and its emitter-collector current flows through the selector magnet coils.

2.97 When Q2 conducts, its base is held at about -25.2 v dc by ZD1 and CR4. The current through R3, R4, and R5 is about 0.5 ampere, most of which flows through the selector magnet coils and the collector. Rheostat R3, is adjusted for a selector magnet current of 0.5 ampere. This current is constant because reference diode ZD1 is not affected by voltage variations.

2.98 Feedback in the emitter circuits of Q1 and Q2 is used to provide the circuit transitions with a "snap action." When Q2 turns on, the current through feedback resistor R3 rises rapidly and the voltage across it increases. This drives the emitter of Q1 more negative. Therefore, when Q1 turns off it is because of the increasing collector current of Q2.

2.99 Similarly, when Q2 turns off, the current through R3 decreases and the voltage across it decreases, making the emitter of Q1 more positive. In this way Q1 is driven on when Q2 turns off.

2.100 The transient developed in the collector of Q2 when it is turned off is suppressed by the network consisting of CR3, R9, and C1. Diode CR6, added to recently manufactured circuits, prevents destruction of transistor Q1 by accidental shorting of the case (collector) of Q2 to frame ground.

LOCAL AND MOTOR CONTROL CIRCUITS

2.101 The CY (copy) relay (5F3), in the 101C data set, is operated by closure of the CON (connect) relay contacts when the set connects, or by closure of the LCL (local) key contacts 27 and 28. The CY relay releases when the set goes out of the local mode, or when the S (send space) contacts operate on a disconnect.

2.102 The CY relay (5F2), in the 105A data set, is operated by closure of the CR (connect - normally released) contacts when the set connects, or by closure

of the LCL (local) key contacts 27 and 28. The CY relay releases when the set goes out of the local mode or when the SR (send space - normally released) contacts operate on a disconnect.

2.103 In the local mode, the circuit through the CV relay is completed to ground by LCL contacts 25 and 26. Local contacts 29 and 30 close to light the LCL (local) lamp. Using a 101C data set in an originating station, the circuit is completed through the CV relay and OR6 make contacts to ground. If the 101C data set is used in an answering station, the circuit is completed through the AN11 make and OR6 break contacts to ground.

2.104 In a station that uses a 105A data set, the circuit is completed through the CV relay and OH make contacts to ground. This circuit is in effect when a station goes off-hook in either the originate or the answer mode.

READER CONTROL CIRCUITS

2.105 The following circuits are applicable to ASR sets only.

2.106 Using a manual reader, the circuit path goes from 48 v ac through the TD trip magnet, RS break contacts, START switch make contacts, RB or RR break contacts, and TD stop break contacts (on sprocket feed printers) to ground.

Originate Mode

2.107 Using a 101C data set, the circuit goes through CN-32 and OR6 make contacts to ground. If a 105A data set is used, the circuit path goes through CN-32 and OH make contacts to ground.

Answer Mode

2.108 Using a 101C data set, the circuit path goes through CN-32, AN11 make contacts, and OR6 break contacts to ground. If a 105A set is used, the circuit goes through CN-32 and OH make contacts to ground.

Local Mode

2.109 In the local mode, the circuit path goes through LCL contacts 25 and 26 to ground using either a 101C or 105A data set.

2.110 With the switch on the reader in the START position, the start contacts close and the TD trip magnet is put into operation. If the reader runs out of tape or if the tape becomes tight, the start contacts will open. This will cause the trip magnet to release and stop the operation of the distributor and reader. When the tape slackens, the contacts will close and normal operation resumes.

2.111 The RR or RB (receive break) contacts open when a break signal is received from a local or distant station and cause the TD (timer delay) to stop. Depressing the BRK-RLS (break-release) pushbutton will restart the TD.

2.112 When the TD is transmitting to a slower speed station through a converter and the storage device becomes crowded, a restrain signal is sent out causing the RS (restrain) contacts (5F2) to open. This will stop the TD until the storage device empties itself. The TD will then restart automatically.

2.113 Using an automatic reader, the circuit path goes from 48 v ac through the TD trip magnet, RS break contacts, tight-tape break contacts, TDC3 make contacts, and TD stop break contacts (on sprocket feed printers) to ground.

Originate Mode

2.114 Using a 101C data set, the circuit path goes through CN-32 and OR make contacts to ground. If a 105A data set is used, the circuit path goes through CN-32 and OH make contacts to ground.

Answer Mode

2.115 Using a 101C data set, the circuit path goes through CN-32, AN make contacts, and OR break contacts to ground. If a 105A data set is used, the circuit path goes through CN-32 and OH make contacts to ground.

Local Mode

2.116 In the local mode, the circuit path goes through LCL contacts 25 and 26 to ground using either a 101C or a 105A data set.

2.117 Using an automatic reader, the circuit path goes from 48 v ac through the TDC relay, stop break contacts, tape out break contacts, START switch make contacts or TD call in make contacts, WRU break contacts, and RB or RR break contacts to ground.

Local Mode

2.118 Using a 101C data set, the circuit path goes through CP-18, CY make contacts, CP-17, out of service break contacts and low paper break contacts to ground. If a 105A data set is used, the circuit path goes through CP-18 and the CY make contacts to ground.

Originate and Answer Mode

2.119 Using a 101C data set, the circuit path goes through CN-21, CON make contacts, CN-17, to ground and through CP-18, CY make contacts, CP-17, out of

service break contacts, and low paper break contacts to ground. If a 105A data set is used, the circuit path goes through CP-18 and the CY make contacts to ground.

Originate Mode Only

2.120 The circuit path goes through the stop break contacts tape out break contacts, X-ON make contacts, through CP-10 as follows.

(a) If a 101C data set is used, the circuit path continues through the M break contacts and CON make contacts to ground.

(b) If a 105A data set is used, the circuit path continues through the MO make contacts and CY make contacts to ground.

2.121 If the set is in the originate mode and X-ON is sent from the keyboard or answer-back of either station, the function box mechanisms of both stations will respond. The X-ON contacts at both stations will close momentarily. Since a path to ground is found only in the originate station, only the TD at the originate will turn on.

2.122 The TDC relay is released and the TD stops when any of the following conditions occur:

(a) Switch depressed to STOP position

(b) Tape out

(c) X-OFF code transmitted

(d) WRU code transmitted

(e) Break

(f) Clear or disconnect.

2.123 Using a 105A data set, the TDC holding path in the local mode goes through the CY make contacts directly to ground. The TD is operable in local and out of service modes.

2.124 Using a 101C data set, the TDC holding path in the local mode goes through the CY make contacts, out of service break contacts, and low paper break contacts to ground. Therefore, in the out of service position, no path to ground is supplied and the TD will not start. If the TD is started before going into the out of service position, the TDC1 make contacts will provide a holding path to ground so that the TD can operate after the set is switched into the out of service mode.

2.125 A momentary closure of the TD call in function box contacts (5E6) will operate the TDC relay. The TDC2 make contacts close to provide the holding circuit.

The TD call in function box contacts close whenever the set receives the particular code to which the function box is designed to respond.

2.126 On sprocket feed printers, the PJ make contacts (5B2) close to provide a circuit path to ground through the motor control relay. This prevents the motor from turning off during the feeding of a form.

2.127 The PJ break contacts open to turn off the TD during form feed after the form code is transmitted from the tape. After the form feed is completed, the contacts close and the TD will restart automatically.

2.128 Diode CR6 rectifies the 48 v ac to provide half wave dc for the TDC relay. Resistor RS limits the current through filter capacitor C3.

ANSWER-BACK CIRCUITS

Automatic Answer-Back

2.129 When a station answers a call, the relays in the data set provide a path to ground through the answer-back magnet in the following manner. In the 101C data set, the circuit path goes through the M make and CON make contacts. In the 105A data set, the circuit path goes through the MO break and CY make contacts. The answer-back is mechanically prevented from cycling more than once.

Here Is Answer-Back

2.130 The answer-back will cycle once when the HERE IS key is depressed.

WRU Answer-Back

2.131 When WRU is sent from the keyboard or tape, the WRU function box mechanism operates at both the sending and receiving stations. The answer-back at the sending station is mechanically prevented from responding, while the WRU function box mechanism trips the answer-back at the receiving station.

2.132 On sets with an automatic reader, a set of contacts is associated with the WRU function box mechanism. These contacts momentarily open when the mechanism senses the WRU code. When the WRU is transmitted from the reader, the WRU break contacts momentarily open the holding circuit through the TDC2 relay. This will release the TDC relay and shut off the TD. The answer-back is then transmitted from a distant station without garbling. If, however, the WRU is sent from the tape of a manual reader, garbling will occur.

EOT DISCONNECT CIRCUIT

2.133 The following circuit description mainly refers to ASR and KSR sets. It can be used with RO sets if all references to the EOT transmit are disregarded.

2.134 In half-duplex operation, the disconnect sequence is initiated whenever the sending or receiving station transmits the EOT (end of transmission) code. The EOT function box contacts at both stations close momentarily after the EOT code is transmitted.

2.135 The circuit is arranged so that closing the EOT contacts (6E4) completes a circuit only when the demodulated output is marking. This action prevents disconnecting on a break signal received during the transmission of a character. The break signal could cause the character to appear as the EOT code and initiate a disconnect. However, the break signal duration is such that the demodulator output will be spacing at the time the EOT contacts close.

2.136 When traffic is transmitted from tape, the EOT code is usually followed by a DELETE character to prevent the transmission of an extra character before disconnecting.

2.137 Circuit operation using a 101C data set: The circuit path is from -20 v dc through the S relay, the EOT contacts (when closed), and through the collector and emitter of switching transistor Q9N to +20 v dc. When the demodulator output is marking, the base of transistor Q8N is positive with respect to its emitter. (The output of Q3A is ground on marking and -20 v dc on spacing.) Transistor Q8N then conducts and causes the base of Q9N to be negative with respect to the emitter. Transistor Q9N will then also conduct and complete the circuit path from +20 v dc to -20 v dc and through the S relay when the EOT contacts close. The S relay then initiates the disconnect sequence. The SR relay is held operated through its holding contacts.

2.138 Circuit operation using a 105A data set: The circuit path is from -20 v dc through the SR relay, the collector and base of 2Q2, the EOT contacts, and the base and emitter of transistor 2Q6 to ground. Transistor 2Q2 conducts whenever the demodulator output is marking. When the EOT contacts close, if transistor 2Q2 is conducting, the base of transistor 2Q6 will be more negative than the emitter. Transistor 2Q6 will then also conduct and provide a complete circuit path from ground, through its emitter and collector, through the SR relay, to -20 v dc. This operates the SR relay which initiates the disconnect sequence.

RINGER AND OFF-HOOK CIRCUITS

2.139 Set connected to 101C data set: The initial station line circuit path is from the ring side of the telephone line to the parallel-connected bell, the RU relay, through the AN and OR break contacts, and to the tip side of the telephone line.

2.140 At the originating station, the ORIG (originate) pushbutton is depressed, the OR relay operates, and its transfer contacts break the connection of the bell and RU relay between ring and tip. At stations with a tone dialer (M option), a strap is used in place of the rotary dial

contacts. When this action is completed, an off-hook condition is presented to the central office.

2.141 At the answering station, the ac ringing current is received from the central office. If the called station is in the automatic answer mode, the ringing current operates both the bell and the RU relay. The RU relay operates the AN relay, which is held operated by its holding contacts. The AN transfer contacts break the connection of the bell and RU relay and connect the hybrid transformer into the circuit between ring and tip. This action presents an off-hook condition to the central office.

2.142 Set connected to 105A data set: The initial station line circuit path is from the ring side of the telephone line to the parallel-connected bell and RU relay, through the OH break contacts, and to the tip side of the telephone line.

2.143 At the originating station, the ORIG pushbutton is depressed, the OR relay operates and, in turn, operates the OH relay. The OH transfer contacts break the connection of the bell and RU relay, and connects the rotary dial contacts, which are in series with the hybrid transformer, into the circuit between ring and tip. At stations with a tone dialer (M option), a strap is used in place of the rotary dial contacts. When this action is completed, an off-hook condition is presented to the central office.

2.144 At the answering station, the ac ringing current is received from a central office. If the called station is in the automatic answer mode, the ringing current operates both the bell and the RU relay. The RU relay operates the OH relay, which is held operated by its holding contacts. The OH transfer contacts break the connection of the bell and RU relay and connects the hybrid transformer into the circuit between ring and tip. This action presents an off-hook condition to the central office.

OUT OF SERVICE CIRCUIT

2.145 The following circuit description mainly refers to ASR and KSR sets. It can be used with RO sets if all references to the dialer and speaker amplifier are disregarded.

2.146 The OUT OF SERV (out of service) switch is used to prevent the set from automatically answering incoming calls. The OUT OF SERV lamp is lighted by the closure of contacts 7 and 8 to indicate this condition.

2.147 When the switch is turned to the OUT OF SERV position, the set will respond in one of two ways, depending on the option selected. With the A (don't answer) option, the ringer and RU relay are made inoperative by shorting when contacts 5 and 6 close. With the B (make

busy) option, the ringer and series capacitor are shorted when contacts 5 and 6 close. This makes the station appear to be off-hook or busy to the central office.

2.148 The NL (nonlocking) contacts 1, 2, 3, and 4 of the OUT OF SERV switch are used at terminal hunting stations, where the switch is rotated to the RESTORE position until a dial tone is heard. In this position the contacts do the following:

- (a) Make contacts 3 and 4 short the tip to ring, producing an off-hook condition, which detected by central office. The central office releases the set from lock-out and applies the dial tone.
- (b) Make contacts 1 and 2 apply ground to the speaker amplifier, permitting it to pass the dial tone.

PAPER ALARM CIRCUIT

2.149 The paper alarm circuit operates an audible alarm (buzzer) and warning lamp to alert the operator when the tape or paper supply is low. In addition, it prevents the set from automatically answering a call during an alarm condition.

2.150 When the typing unit paper supply is low, the low paper switch will operate. On friction feed typing units, this switch will operate when the paper roll decreases to a predetermined diameter. On sprocket feed typing units, the switch will operate when a bail drops through a notch in a form near the end of the supply.

2.151 Operation of any of these switches will close the circuit from 10 v ac to ground by going through the buzzer and the BUZ-RLS (buzzer release) lamp. The buzzer sounds. Depressing the BUZ-RLS pushbutton will turn the buzzer off but the BUZ-RLS lamp will remain on until one of the other pushbuttons is depressed.

2.152 Set connected to 101C data set: The automatic answer circuit path is from -20 v dc through the AN relay, RU make contacts, CY break contacts, out of service switch break contacts and low paper switch break contacts to ground.

2.153 On automatic answer, the RU (ring up) make contacts (8B5) close to operate the AN (answer) relay, which remains operated because of its holding contacts.

2.154 Set connected to 105A data set: The automatic answer circuit path is from +20 v dc through the OH relay, OR break contacts, RU make contacts, CY break contacts, out of service switch break contacts and low paper switch break contacts to ground.

2.155 On automatic answer, the RU (ring up) make contacts (8B6) close to operate the OH (off-hook) relay which remains operated because of its holding contacts.

2.156 The automatic answer is disabled during the following conditions regardless of which data set is used:

- (a) **Set in Local Mode:** In the local mode, the CY relay is operated and its break contacts are open, preventing automatic answer. On an incoming call, the ringer sounds and the ANS lamp flashes. The call may be answered manually by depressing the ANS pushbutton.
- (b) **Low Paper:** The low paper break contacts open, preventing automatic answer from taking place. On an incoming call the ringer will sound and the ANS lamp will flash. The call may be answered manually depressing the ANS pushbutton.
- (c) **Out of Service:** The out of service break contacts open preventing automatic answer from taking place and also disabling the ringer. The ANS lamp will flash on incoming calls. The call may be answered manually by depressing the ANS pushbutton.

POWER CIRCUITS

2.157 The following circuit description refers mainly to ASR sets. It can be used with KSR sets if all references to the tape reader and tape punch are disregarded. It can be used with RO sets if all references to the tape reader, tape punch, and the rectifier are disregarded.

2.158 The 115 v ac input supplies the power for the following items:

- (a) Motor
- (b) Selector magnet driver transformer
- (c) Power transformer (10-14-48 v ac)
- (d) Elapsed time indicator
- (e) Rectifier on reader card.

2.159 The elapsed time indicator and motor are operated by the motor control relay make contacts.

2.160 When the TD trip magnet operates it causes the TD feed magnet to energize. The feed magnet raises the reader sensing pins while the distributor transmits the start pulse. If a hole is present in the tape, the code contacts will be closed. If no hole is present in the tape, the code contacts will be open.

2.161 The TD trip magnet remains energized and the sensing pins remain up when the distributor transmits the 8th code pulse. At the end of the 8th code pulse, the

TD feed magnet contacts open causing the magnet to de-energize. This will cause the feed wheel to stop and the sensing pins to retreat.

2.162 When the distributor transmits the start pulse, the TD feed contacts will close and the cycle will be repeated.

3. CIRCUIT SWITCHING SERVICE

3.01 Circuit switching service operates over short and intermediate length telegraph loops using neutral signaling or, over longer loops with polar signaling when modified with proper polar-to-neutral converting circuitry. Within the unit are a power supply circuit, and a motor delay timer circuit.

POWER SUPPLY CIRCUIT

3.02 A fused power supply circuit (Figure 1), operates on 117 volts ac ± 10 percent at 60 hertz $\pm 1/2$ hertz, and a power input of 12 watts. The power supply ground is floating with respect to the input signal line; that is, it is not at earth ground. Therefore, the center tap of the transformer is $+120$ volts from earth ground in neutral signaling. The polar adapter, on teletypewriters so equipped, also contains a power supply. This power supply, as well as the one found on the call control unit, uses an earth ground.

LOCAL-REMOTE CONTROL CIRCUITS

3.03 The local-remote control consists of three printed circuits placed upon the same circuit card that accomplish the switching called for by the line input or the call control unit pushbuttons. The three circuits are, proceed-to-dial, connect, and local. The circuits are essentially made up of binaries (flip-flops) that have been modified to perform certain functions. All three circuits are protected with a diode arc suppressor against transients and voltage pulses generated by their associated relays.

3.04 A negative voltage, generated at the collector of a transistor will be shorted through the diode to resistor R27. The transient will be developed across R27 and the lamp associated with the relay. The diodes that suppress the transients in each circuit are C10, C12, and C19. The circuits are also protected from transient noise induced into them from leads in the cable to the dial and key and lamp assembly. A low-pass filter or delay network of the RC type is placed in a feedback loop in each binary. These delay networks are made up of R10 and C3, R21 and C4, and R39 and C11.

3.05 The signal line inputs are filtered against spurious noise occurring on the signal line. There are two of these RC type filters. In the proceed-to-dial circuit, R5 and C1 provide a 0.001 second delay while, R12 and C2 provide a

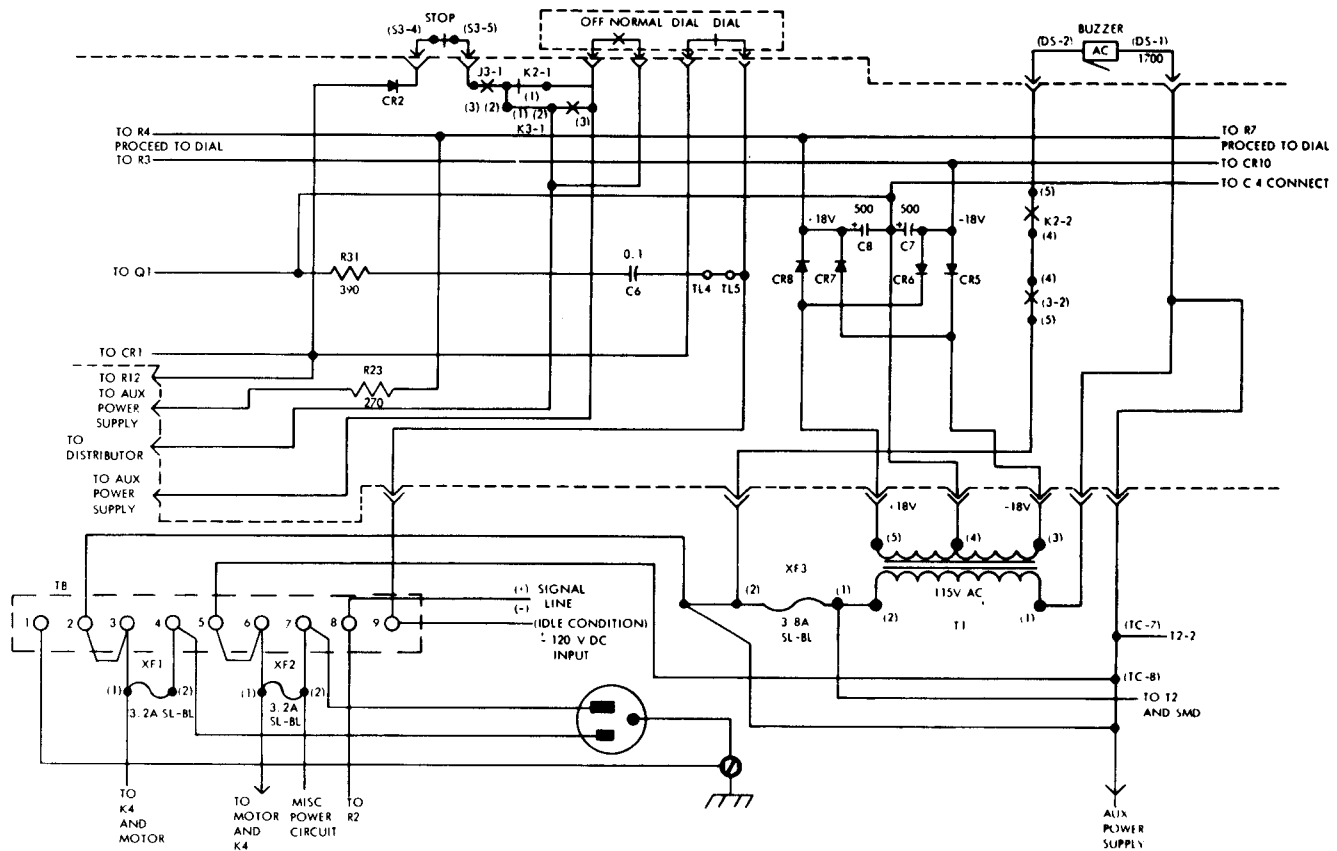

Figure 1 - Power Supply Circuit

0.02 second delay in the connect circuit. The network consisting of R31 and C6 found in the 240 volt signal line, acts as an arc suppressor to protect its associated contacts. This network may be removed from the signal line by removing the strap between terminals TL4 and TL5. Additional network components may be added to these terminals, if required.

A. Proceed-to-Dial Circuit

3.06 The proceed-to-dial circuit (Figure 2), consists of a binary with a line input amplifier. The amplifier consists of transistor Q1 and its associated components, and the binary consists of transistors Q2 and Q3 along with their associated components. The amplifier is connected to the binary through a low-pass filter delay network (R5 and C1) which suppresses signal line noise. The input to the binary, coming from the filter network and passing through R6, will turn on the proceed-to-dial circuit. Control inputs through R15 and the stop pushbutton contacts 1 and 2, are used to turn off the circuit. Operation of the transistors in the proceed-to-dial circuit is as follows:

(a) When transistor Q2 is in conduction, its collector is very near a neutral potential. Current will flow through Q2, R11, stop pushbutton contacts 1 and 2, and R27. Current will also flow from +18 volts through R8 and CR9 to the collector of Q2. The base of Q3 will be held at +0.8 volts with respect to the collector of Q2 due to the current flow of CR9. The base of Q3 will therefore, be slightly positive with respect to neutral, and Q3 will be turned off. With Q3 off, its collector will be negative and Q2 will be held in conduction. This is accomplished by applying current to the base of Q2 supplied through the low-pass filter made up of R9, R10, and C3.

(b) When transistor Q3 is in conduction, the proceed-to-dial circuit will be on and the collector of Q3 will be very near neutral. Current will flow through Q3, K1, the dial lamp, and R27. Since the collector of Q3 is near neutral, current flow through R7, R9, and R10 will produce a positive potential at the base of Q2. This positive potential will hold Q2 off. With Q2 held off, base current for Q3 will flow through CR9, R11, stop pushbutton contacts 1 and 2, and R27. This flow of current will hold Q3 in conduction.

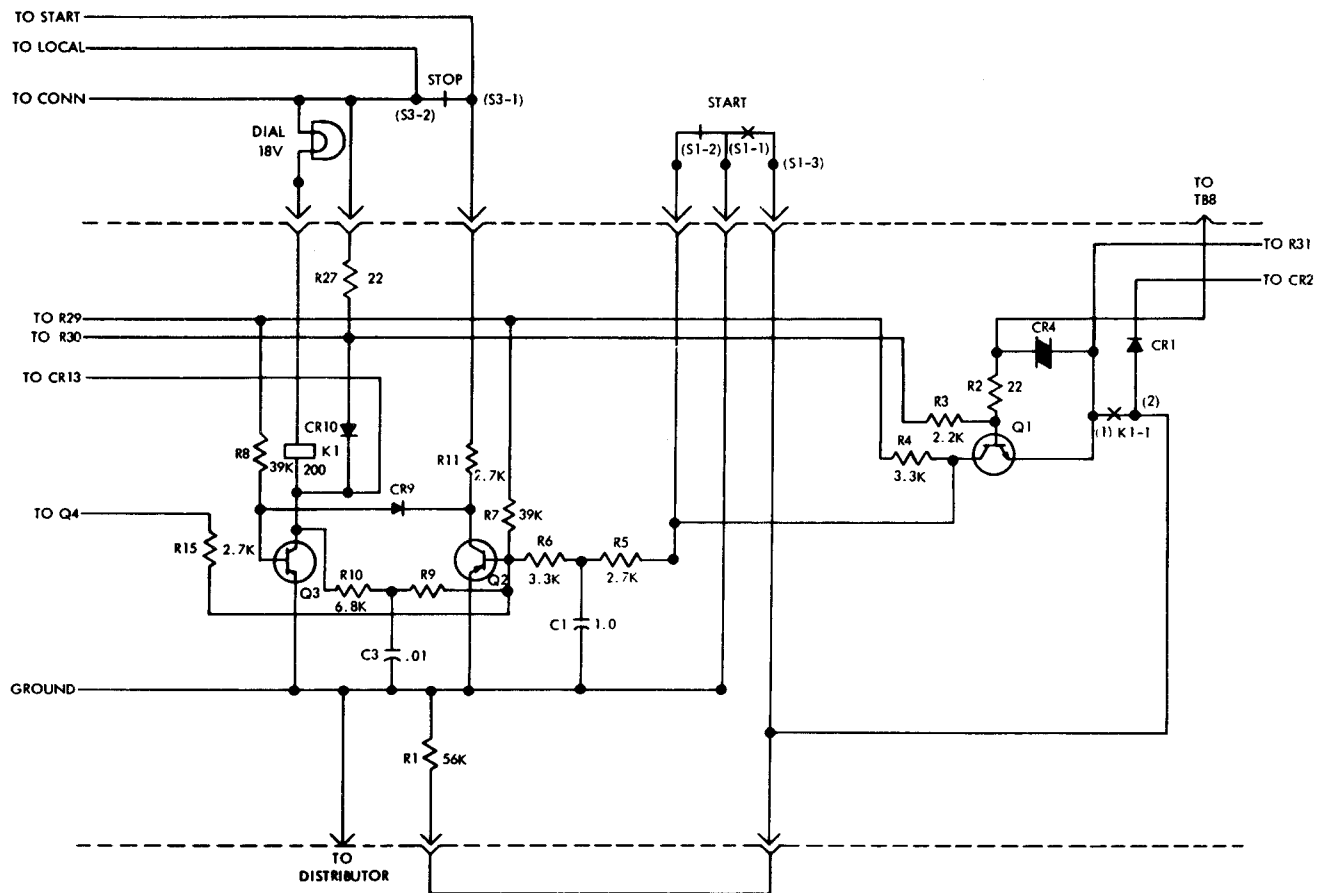

Figure 2 - Proceed-to-Dial Circuit

(c) If an input current in excess of 0.009 ampere flows from TB-8 across CR4 to neutral, a positive potential of 0.8 volts will be developed across CR4. This positive potential will hold Q1 in conduction and its collector near neutral. The neutral condition has no effect upon the base of Q2 because of the isolation provided by R5 and R6. If the input current falls below 0.009 ampere, a negative potential of 0.8 volts is developed across CR4 due to current flow through R3, R2, and CR4. This potential will turn off Q1 and its collector becomes positive. Current now flows through R4 and R5 to charge C1 towards a +18 volts. When a sufficient voltage is developed across C1, the base of Q2 will be back-biased through R6. Transistor Q2 turns off and Q3 turns on placing the proceed-to-dial circuit in the on condition. Back-bias to the base of Q2 is supplied by the voltage divider R7, R9, and R10 so that the positive potential across R6 is no longer required to hold Q2 off. If more than 0.009 ampere begins to flow across CR4 again, Q1 will turn on, and its collector will go to neutral, but this will have no effect on the base of Q2.

(d) If a negative signal is applied to the side of R15 opposite the base of Q2, enough current will flow to forward-bias the base of Q2 and cause it to conduct. Q3 will turn off and supply sufficient base current through R9 and R10 to hold Q2 in conduction. The negative signal on R15 can now be removed, and Q2 will remain in conduction.

(e) With the proceed-to-dial circuit on, Q3 will be in conduction. Base current for Q3 will flow through R11 and CR9. Depressing the STOP pushbutton causes contacts 1 and 2 to open breaking the current path. Transistor Q3 will then turn off and Q2 will turn on. There will be no collector current flowing in Q2; therefore, the collector will be near neutral holding Q3 off. When the STOP pushbutton is released, collector will flow in Q2 and the proceed-to-dial circuit will turn off.

B. Connect Circuit

3.07 The connect circuit (Figure 3) consists of a binary (Q4 and Q6) of which one side is driven by emitter follower Q5. The only control input to this circuit is by the

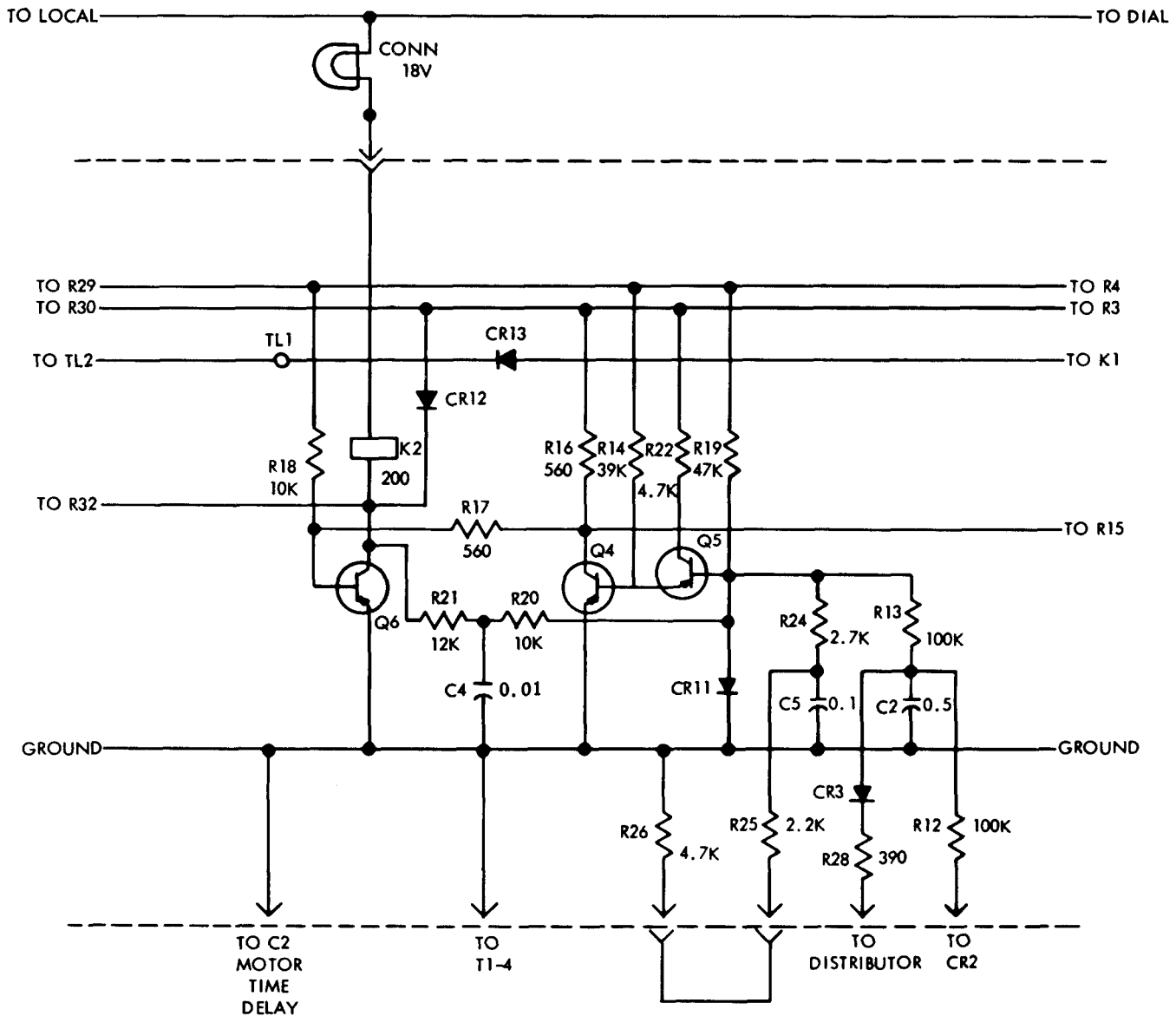

Figure 3 - Connect Circuit

signal line through R12 and R13. A signal delay of approximately 0.02 seconds is provided by the low-pass filter network consisting of C2 and R12. A single passive control, consisting of R28 and CR3, is used for low-paper conditions.

(a) Transistor Q5 controls the base of Q4. When transistor Q4 is in conduction, its collector is very near a neutral potential. A voltage divider consisting of R17 and R18 hold the base of Q6 positive so that Q6 is off. This will make the collector of Q6 go negative and also make the base of Q5 go negative by the current path through R20 and R21. Since Q5 is an emitter follower, its emitter will be held at the same potential as its base. With its emitter at a negative potential, Q4 will be held on.

(b) When the connect circuit is on, Q6 will be in conduction and its collector will be near a neutral potential. The voltage divider R19, R20, and R21 holds the base of Q5 and therefore the emitter, at a positive potential. With the emitter of Q5 at a positive potential, the base of Q4 will be reverse-biased, the transistor will be off, and its collector will go negative. The connect circuit will be held on by the base for Q6 that flows through R16 and R17.

(c) To control the connect circuit a high voltage must be developed at the junction of CR1 and CR2 (circuit card TP305689). This voltage will be approximately ± 200 volts. If a $+200$ volt signal is applied at this point, the base of Q5 will be biased positive. Q4 will

turn off and Q6 will turn on. If a -200 volt signal is applied, the base of Q5 will be biased negative, Q4 will turn on and Q6 will turn off. An input signal at or near a neutral potential will have no effect upon the connect circuit, and it will remain in its prior state.

(d) The base of Q5 is protected against excessively high voltages by transistor operation or by CR11. If a -200 volt signal is present, the voltage on the base of Q5 will go in a negative direction and force its emitter to follow. When the emitter of Q5 becomes negative with respect to ground, Q4 will turn on. With Q4 in conduction, the potential on its base will be close to the emitter. Therefore, the base cannot go more negative than -0.4 volts. This action will hold the base voltage of Q4 to within -0.4 volts of its emitter. Therefore, the base voltage of Q5 cannot become more negative than -0.8 volts. If a +200 volt signal is present at the input, the base of Q5 will start to become positive. The diode CR11 is forward-biased to positive base voltages. It will, therefore, limit the base voltage of Q5 to +0.8 volts. Therefore, under the severest input conditions, a voltage swing of more than ± 0.8 volts is not expected.

(e) Resistors R24, R25, R26 and capacitor C5 are used where a polar converter is employed. They are shown all connected together and have no effect upon the operation of this circuit.

C. Local Circuit

3.08 The local circuit (Figure 4), consists of a binary and a unijunction transistor timer. The binary operation of Q8 and Q9 is the same as that described in the proceed-to-dial circuit. Four input controls are available for use with the local circuit.

(a) Operation of the LOCAL pushbutton allows transistor Q9 to go into conduction and also turn the local circuit on. When contacts 1 and 2 are closed, base current will be supplied to Q9 through R37 and R38 causing Q9 to turn on and Q8 to turn off. If the anode of either CR13 and CR14 is neutral, the current flowing through R38 will flow through one of these diodes and not reach the base of Q9. These two diodes allow the local circuit to be turned on only when the proceed-to-dial and the connect circuits are off.

(b) The local circuit can be turned off by depressing either the START or the STOP pushbutton. When the local circuit is on, the base current of Q9 flows through start contacts 4 and 5 and stop contacts 1 and 2. Since the contacts of the two pushbuttons are in series, operating either of them will turn Q9 off. The output of unijunction transistor Q7, will also turn off the local circuit as it is basically a breakdown device.

(c) If the voltage on C9 is more negative than approximately -8 volts, the resistance of the junction between the lead connected to C9 and the lead connected to R35 is high. When the voltage on C9 becomes more positive than -8 volts, the resistance of this junction will become very low, and C9 will recharge through R35. The increase in current flowing through R35, while recharging C9, will cause an increase in the voltage drop R35. The positive pulse is coupled through C10 and CR17 to the base of Q9 and causes it to turn off and Q8 to turn on. The local circuit is then off. As capacitor C9 is recharged, the resistance of the junction again becomes high.

(d) Capacitor C9 is discharged toward neutral or held at about -18 volts through R32 and R33. If the input to R32 is negative (connect circuit off), C9 will be held at -18 volts. If the input to R32 is near neutral (connect circuit on), capacitor C9 will discharge through R32 and R33 toward neutral. At the end of a 2.3 second interval, the voltage on C9 will be approximately -8 volts and the unijunction will break down and turn the local circuit off as described above.

MOTOR DELAY TIMER CIRCUIT

3.09 The motor delay timer circuit (Figure 5), provides the means to delay motor turn-off in the teletypewriter. This allows the teletypewriter to complete its printing cycle and come to rest before the motor begins to stop. This circuit, along with the selector magnet driver circuit, are mounted on the same circuit card but are electronically independent of each other. The circuit is designed to drive a motor control relay connected between points 3 and 5 and is operated when either the connect or local circuit is on.

3.10 The motor delay timer consists of a regenerative switch (Q3 and Q4) and an output driver (Q2). The input to the motor delay timer is from the collector of Q9 through diode CR16 or from the collector of Q6 through diode CR15 in the local and connect circuits of the local-remote control circuit. The diodes provide insulation between the input of the motor delay timer and the transistors of the local-remote control for negative signals. When the input of the motor delay timer at point 2 is grounded, the output driver will turn on immediately. When the input signal is removed, the output driver will remain in conduction for 0.55 seconds while holding the motor relay operated long enough to allow the teletypewriter to complete its printer cycle before turning off the motor.

3.11 When a negative input signal is applied to point 2, base current to Q3 will flow through R13, R15, and R14. Q4 will be held in conduction by the base current flowing through R12 and R16. The collector of Q3 will be close to -1.6 volts. The voltage divider R12 and R16, will hold the base of Q2 positive and therefore Q2 will be cut off.

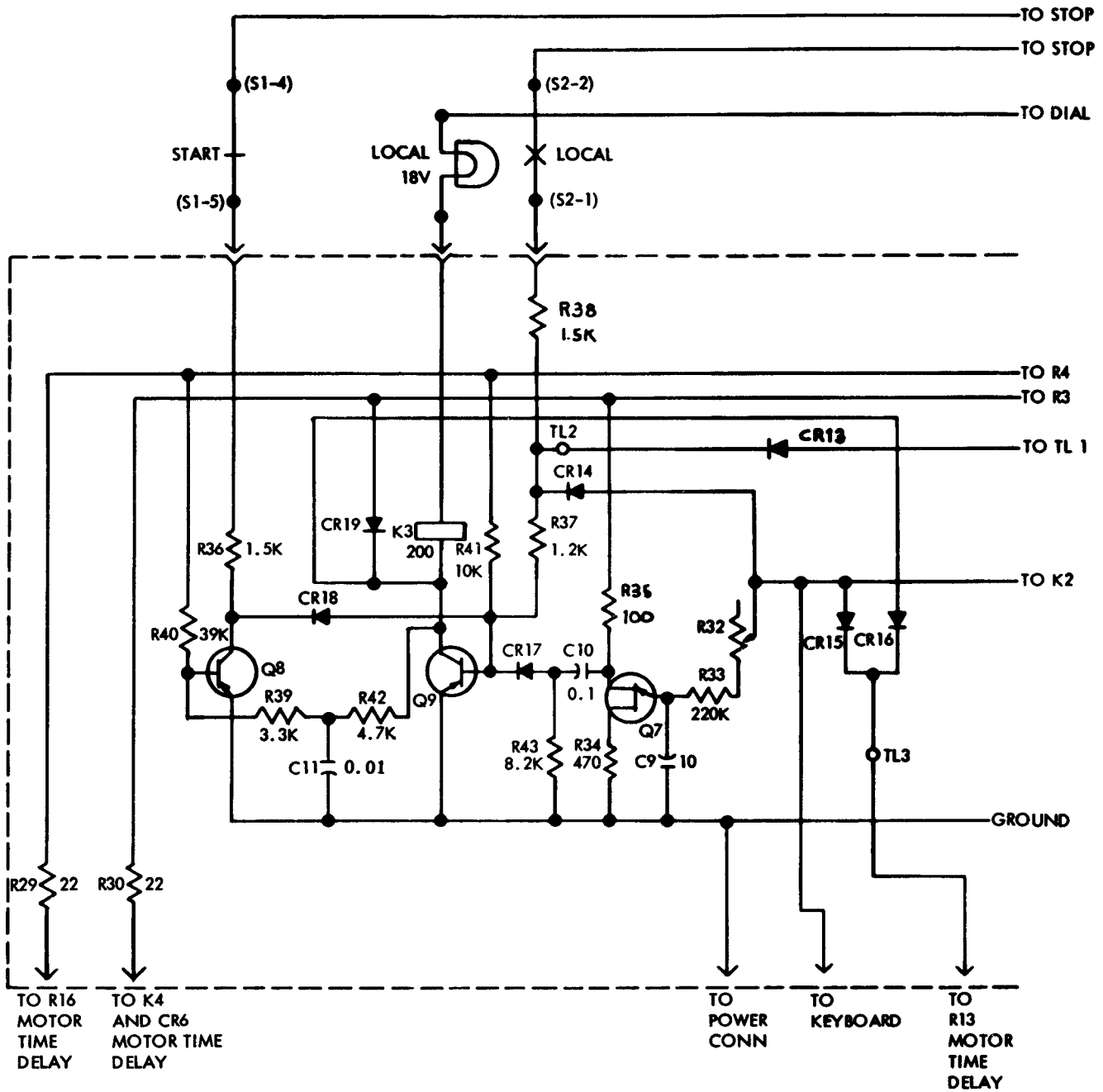

Figure 4 - Local Circuit

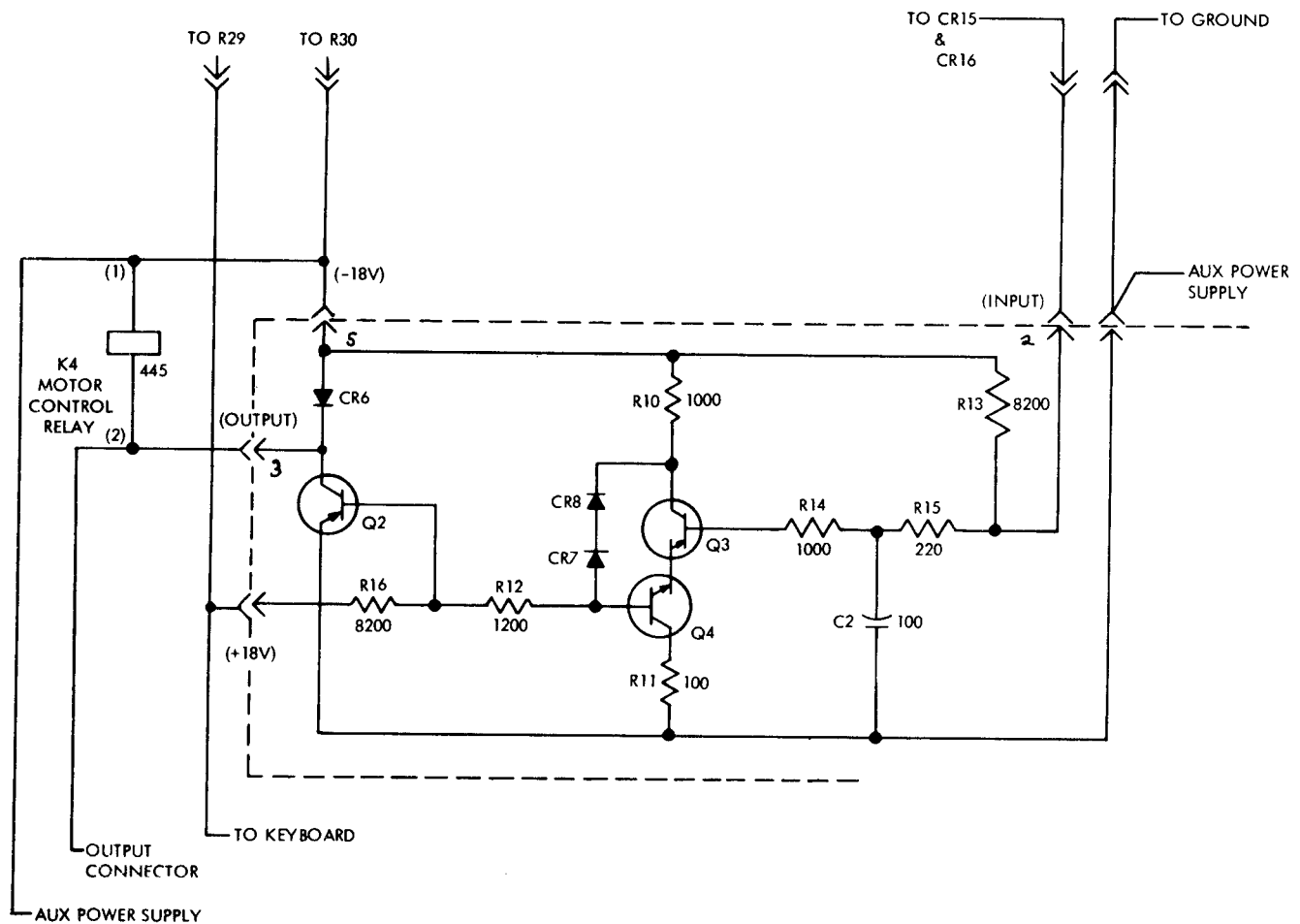

Figure 5 - Motor Delay Timer Circuit

3.12 If ground is now applied to the input, the base of Q3 will approach ground and become reverse-biased. This will turn Q3 off. The collector of Q3 will now be at a potential of -10 volts. This voltage will cause the voltage at the base and emitter of Q4 to be at a potential of -8.5 volts. The emitter of Q3 will be held at -8.5 volts by the emitter of Q4. This will hold Q3 off. The -10 volt potential at the collector of Q3 will cause base current to flow to Q2 through CR7, CR8, and R12. Q2 will then go into conduction, and operate the external motor control relay.

3.13 If the ground input is now removed, current will flow through R13 and R15 and charge C2 toward -18 volts. After about 0.55 seconds the voltage on C2 will reach -8.5 volts and Q3 will go into conduction with its collector going less negative. This causes the base of Q4 and, therefore, the emitter of Q3 and Q4, to become less negative. This process will continue until both Q3 and Q4 are saturated. C3 will then discharge through R9 and the base of Q3 to ground. Base current to hold Q3 in conduction is supplied through R13, R15, and R14.

3.14 At 25 degrees C, with a 390 load, the delay of the motor timer is from 0.475 second to 0.675 second when the supply voltages are within 3 percent of their nominal values.

SELECTOR MAGNET DRIVER CIRCUIT

3.15 The selector magnet driver circuit (Figure 6), combined with an external power transformer, and a filter capacitor, provides 0.500 ampere current for driving the selector magnet from a telegraph signal source of appropriate input line current. The input signals are applied through terminals 6 and 11, with R1 determining the switching level.

3.16 For a mark input, a positive current is applied to terminal 11. This will provide a positive bias to the base of transistor Q1 that overcomes the normal negative bias supplied through R1 and stabilized by zener diode ZD1. Q1 will turn off as the increasing positive current reaches one-half of its final value. The collector of Q1 then goes

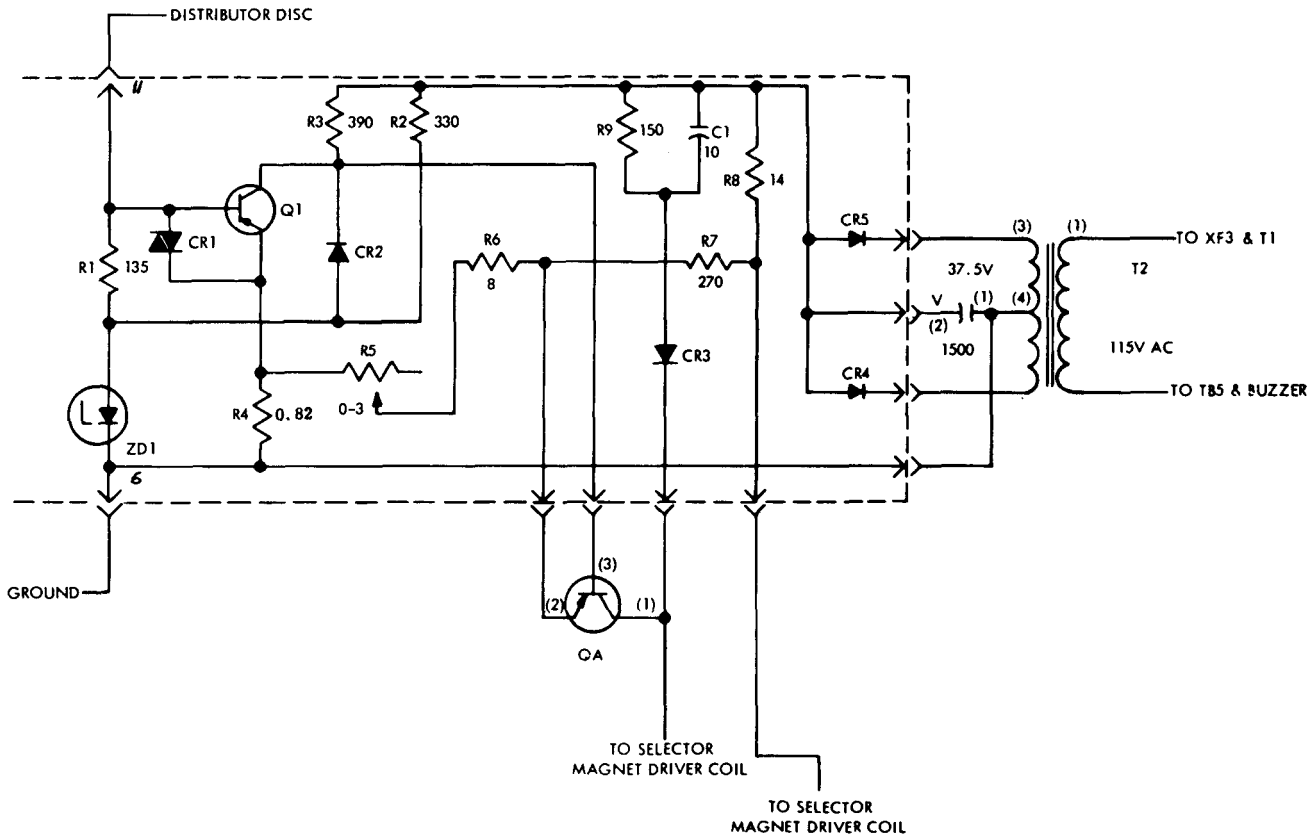

Figure 6 - Selector Magnet Driver Circuit

negative and this negative potential is applied to the base of QA and turns QA on. R4 will provide emitter bias to Q1, and supplies a regenerative action to the transistor.

3.17 The selector magnet is connected between the collector of QA and the junction of R7 and R8, and supplies the load for QA. On marks, the current rises to 0.500 ampere and energizes the selector magnet. On spaces, the positive input bias decreases, and Q1 is turned on at the half-line current point by negative bias through R1. The collector of Q1 rises towards a zero potential, applying reverse-bias to QA, turning off QA, and de-energizing the selector magnet. The selector magnet opposes the change in current, and it applies a transient potential to the collector of QA. CR3 will now conduct and pass the transient potential to C1 and R5 which limits the potential to a value well under the breakdown voltage QA while selector magnet energy is being dissipated.

NEUTRAL SIGNALING

A. Circuit Interconnections

3.18 The block diagram for the circuit interconnections is shown in Figure 7.

Proceed-to-Dial

3.19 In order to turn on the proceed-to-dial circuit, two conditions must be satisfied: The START pushbutton must be depressed and the proper line signal must be received from the exchange. The START pushbutton presents the proper signal to the exchange so that the request to dial is recognized. It also protects the circuit from an open line and long line breaks such as those generated when dialing.

3.20 The proceed-to-dial circuit can be turned off in two ways: By the depression of the STOP pushbutton or by the operation of the connect circuit. Local control is provided by the STOP pushbutton while the connect circuit provides automatic control initiated by the exchange.

3.21 The connect circuit is controlled only by the line and, therefore, has only one input which comes from line sensing and control.

Local Circuit

3.22 To turn on the local circuit, the following conditions must be satisfied:

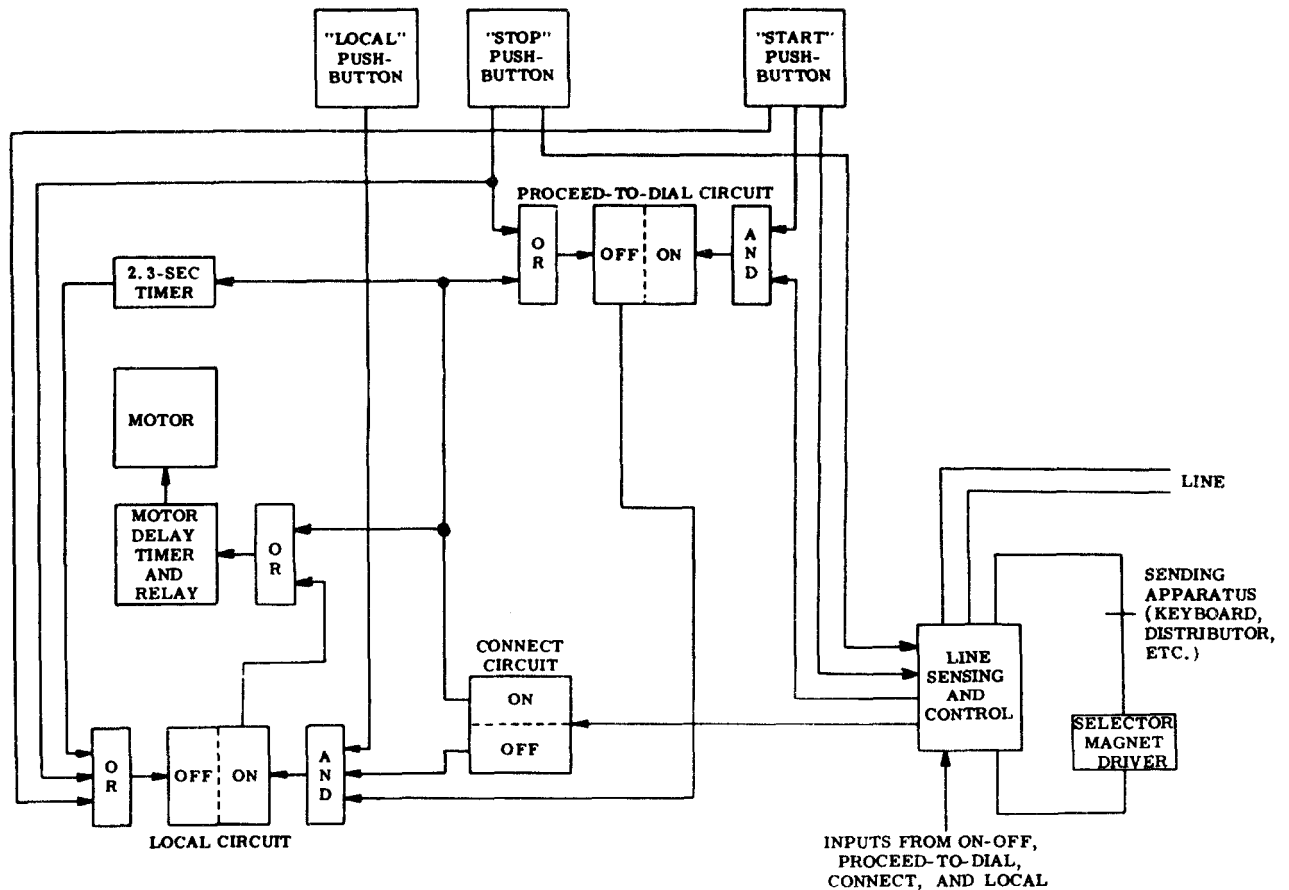

Figure 7 - Circuit Interconnections

(a) The proceed-to-dial and the connect circuits must be off, and the LOCAL pushbutton must be depressed.

(b) The input of both the proceed-to-dial and the connect circuit protect against the accidental operation of the local circuit which would otherwise cause an automatic disconnect.

3.23 The local circuit is turned off by depressing the STOP pushbutton, the START pushbutton, or the 2.3-second timer. The START and STOP pushbuttons provide local control of the circuit, while the 2.3-second timer provides the automatic control. The timer is controlled by the connect circuit which is, in turn, controlled by the line. The timer will continue to oscillate as long as the connect circuit is on although only the first timing pulse is required to turn off the local circuit.

3.24 Each of the circuits mentioned has an input to the line sensing and control. The inputs are in the form of relay contacts which switch the line through the proper internal path in the local and remote control assembly. When

either the connect or local circuit is on, a motor control relay is operated. The contacts of the relay are used to turn on the motor of the associated typing unit.

B. Idle Line Conditions

3.25 The schematic diagram of the local-remote control circuit (Figure 8) shows the current flow during the idle line condition. In this state, all relays and lamps are off. This requires that transistors Q3, Q6, and Q9 be off and that Q2, Q4, and Q8 be in conduction. The output transistor of the motor delay timer is off, and the selector magnet driver is marking.

3.26 The signal loop is a 240-volt source with 4000 ohms in series. In the idle condition the local-remote control offers 43,800 ohms of local resistance to the signal loop. The flow of loop current in this condition is shown in Figure 8. Current flows from TB8, the positive idle terminal, across CR4, through R1 and CR1 in parallel with the base emitter junction of Q4 and Q5, R13 and R12. From this point, current flows through the dial pulse contacts to terminal TB9.

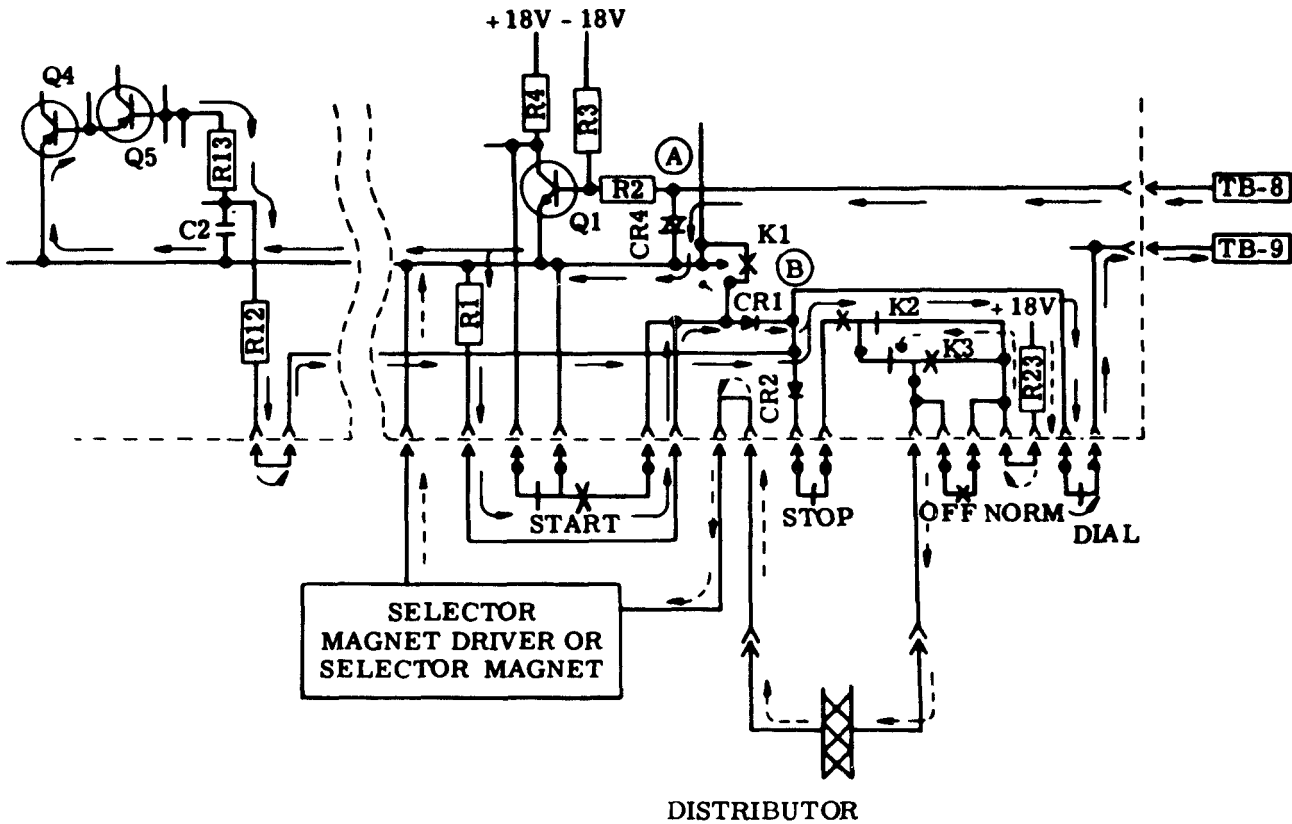

Figure 8 - Local-Remote Control Circuit - Current Flow (Idle)

3.27 The loop current develops a positive potential at A in Figure 8 holding Q1 on. The collector of Q1 is shorted to ground through START pushbutton contacts 1 and 2. Therefore, no signal may be developed at the collector unless the START pushbutton is depressed. The loop current develops approximately a -200 volt potential at point B. This potential will hold Q4 in conduction while holding Q6 and the connect circuit off.

3.28 To locally hold the selector magnet driver and the distributor at neutral, a 0.060 ampere current is supplied through R23 and flows through K2 relay contacts 1 and 2, and K3 relay contacts 1 and 2.

C. Initiating a Call

3.29 A call can be initiated with the teletypewriter in either the idle or local condition by depressing the START pushbutton. This performs three functions: Contacts 4 and 5 open to turn off the local circuit; contacts 1, 2, and 3 operate shorting the local loop resistance, allowing the loop current to rise to 0.060 ampere; contacts 1 and 2 open to remove the short from the collector of Q1. The collector will remain at ground since more than 0.002 ampere is flowing through C4. The loop current now flows from TB8, through CR4, START pushbutton contacts, CR1, and the dial impulse contacts to TB9. Shorting out the local loop

resistance causes the voltage at point A to rise to neutral. This action has no effect on the state of the connect circuit.

(a) Proceed-to-dial: When the START pushbutton is depressed, a proceed-to-dial pulse will cause the collector of Q1 to go positive and, in turn, operate the proceed-to-dial circuit (turn Q3 on). With Q3 in conduction, current will flow through relay K1 and the DIAL lamp. This causes both of them to be operated. The normally open contacts 1 and 2 of the K1 relay will operate and short the START pushbutton contacts 1 and 3. Loop current now flows from TB8, through CR4, K1 relay contacts 1 and 2, CR1, and the dial pulse contacts to terminal TB9.

(1) With Q3 in conduction, its collector will be near neutral, CR13 will be forward-biased, and depending on the strapping of TL1, 2, and 3, will either hold the junction of R37 and R38 in the local circuit near neutral and, therefore, preventing the operation of the local circuit or will cause the motor to start.

(2) The proceed-to-dial circuit may be turned off by depressing the STOP pushbutton. STOP contacts 1 and 2 will open causing Q3 to turn off

and the unit to revert to the idle line condition. The current loop is shown in Figure 8.

- (3) If the START pushbutton is released any time before the proceed-to-dial pulse is given by the exchange, the unit will revert back to the idle line condition. The START pushbutton should not be reoperated for a few seconds as the exchange requires a short time to reset after this condition.
- (b) Dialing: The dial is in the signal loop at all times, but it may be used to transmit information to the exchange only during the proceed-to-dial and the connect conditions. Since the dial impulse contacts are in series with the loop, operation of the dial will completely break loop current. In order to prevent damage to the dial contacts, an arc suppressor consisting of R31 and C6, is placed across the contacts. Terminal lugs TL4 and 5 are provided so that this network can easily be connected or disconnected or so that additional network components can be placed in series with R31 and C6 as needed.

D. Connection

3.30 The schematic diagram of the local remote control circuit (Figure 9) shows the current flow during the local connection.

3.31 Local Connection: If a call is initiated locally, current in the loop will be 0.060 ampere from TB8 to TB9 through the path described in 3.28 before connection. When the loop polarity is reversed by the exchange, current will flow from TB9 to TB8. Diode CR1 becomes reverse-biased and stops current flow except through R12 and R13. This current flow will turn off Q4 and turn on Q6. With Q6 in conduction, the connect circuit will be on, the K2 relay will operate and the CONN (connect) lamp will light. The contacts of the K2 relay will switch and allow the loop current of 0.060 ampere to flow through the distributor and selector magnet driver as shown in Figure 9. Loop current now flows from TB9, through the dial pulse contacts, CR2, K2 relay contacts 2 and 3, K3 relay contacts 1 and 2, the keyboard distributor, the selector magnet driver, and CR4 to TB8.

3.32 With Q6 in conduction, CR15 will be forward-biased and turn on the output transistor of the motor delay timer. The K4 motor control relay will operate by closing its contacts and turning on the printer motor. Q4 will now be cut off and its collector will go negative. Feedback from the collector of Q4 to the base of Q2 through R15 will turn off the proceed-to-dial circuit. The K1 relay contacts will open and the dial lamp will go out. This will have no effect upon loop current flow since these contacts are not now in the current loop. The junction of R37 and

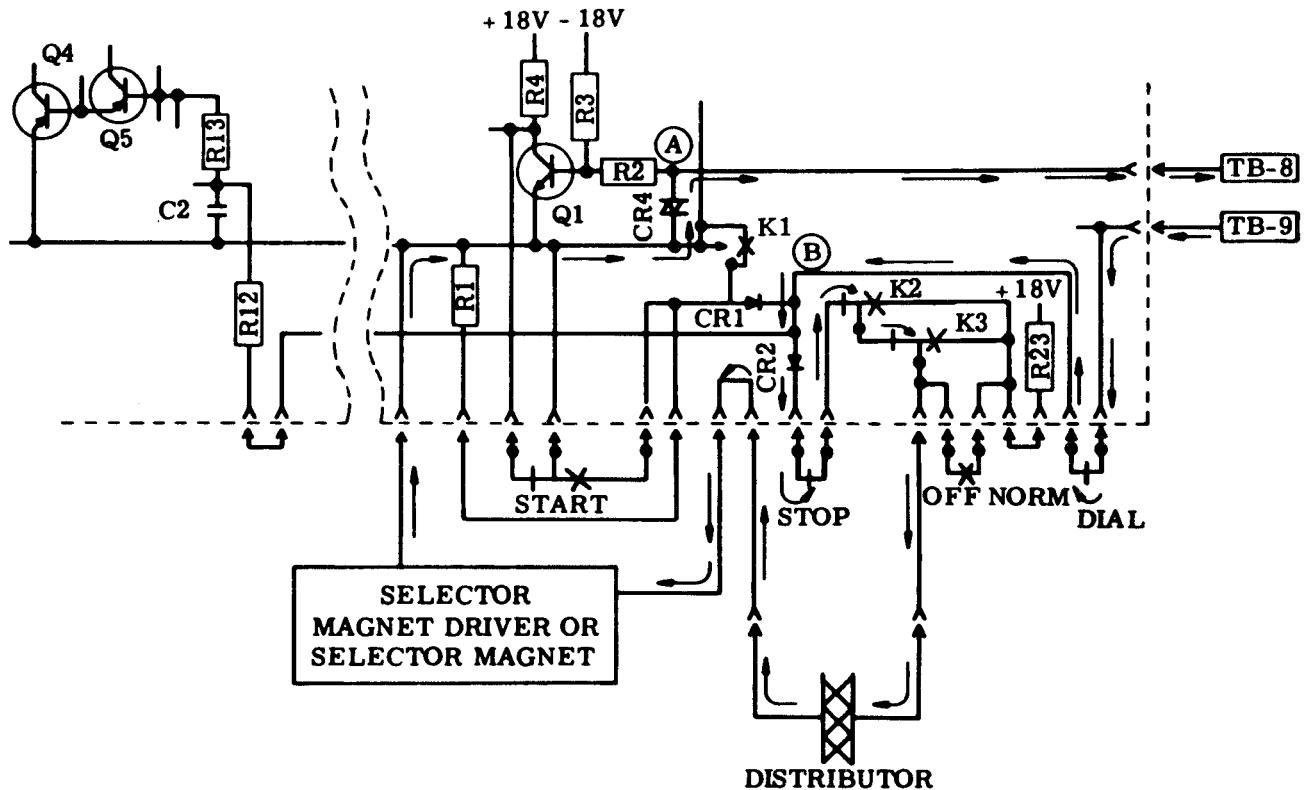

Figure 9 - Local-Remote Control Circuit – Current Flow (Local Connection)

R38 is held near neutral from the collector of Q6 through CR14. This will prevent operation of the local circuit.

3.33 Remote Connection: On an incoming call, the teletypewriter may be connected remotely while in the idle line or local conditions. The loop path is shown in Figure 8 for both of these conditions. The incoming call causes the exchange to reverse the loop polarity. This causes the potential at the junction of CR1 and CR2 to change from -200 volts to approximately +200 volts. The potential causes the connect circuit to operate as described in 3.32

3.34 Low-Paper Circuit: If the paper in a teletypewriter has become low and the low-paper contacts operate, the junction of R12 and R13 will not be allowed to become positive. Q4 cannot be turned off, and a connection cannot be made. If low paper occurs during a call, the teletypewriter will remain in the connected state, since zero potential at the junction of R12 and R13 will not effect the connect circuit. A disconnect will occur in the normal manner, since CR3 will be reverse-biased to a negative potential at the junction of R12 and R13. If a call is initiated locally with a low-paper condition, the normal sequence of events will occur until a connection is attempted. When the exchange cannot connect, it will reverse the loop polarity, and the teletypewriter will return to the idle state.

E. Disconnect

3.35 Local Disconnect: Operation of the STOP pushbutton while in the connect condition opens contacts 4 and 5 which are in series with the loop, and breaks the loop. When the exchange recognizes the break, it reverses the loop polarity. The reverse polarity is blocked by CR2, and current flows through CR1 along the path shown in Figure 8. At point A a -200 volt potential is developed due to the current flow described in 3.26 through 3.28. This potential causes the connect circuit to turn off and the teletypewriter stops running open. The input to the motor delay timer becomes negative, and the timer will time out. After 0.55 second the motor control relay releases, and the motor will turn off.

3.36 Remote Disconnect: The operation of the circuits and the loop paths are the same as those described in 3.33. The STOP pushbutton is not operated locally, but the signal conditions appear identical to the local-remote control.

F. Local Off-Line Operation

3.37 When the teletypewriter is in the idle line condition, depressing the LOCAL pushbutton will cause the local circuit to turn on. If the control is in the proceed-to-dial or connect conditions, either CR13 or CR14 will prevent operation of the local circuit. When the local circuit does operate, the LOCAL lamp will light. K3 relay

contacts 2 and 3 will short out K2 relay contacts 1 and 2 located in the keyboard selector magnet driver loop. Current in this loop will then flow through R23, K3 relay contacts 2 and 3, the keyboard, and the selector magnet driver to neutral. CR16 will be forward-biased causing the output transistor of the motor delay timer to turn on. The motor control relay will operate and the motor will start. The teletypewriter is now ready for off line operation. To return to the idle position, the STOP pushbutton should be depressed. STOP pushbutton contacts 1 and 2 open and turn off the local circuit. A call may be initiated in the usual manner. When the START pushbutton is depressed, its contacts 4 and 5 open and turn off the local circuit the same way as if the STOP pushbutton were used.

(a) If an incoming call is received while the teletypewriter is in the local condition, the action of the circuit is the same as that described in 3.30 through 3.32. The K2 relay operates to shunt the line through the keyboard distributor and selector magnet driver, but this operation cannot be accomplished since the K3 relay contacts 2 and 3 have shorted the K2 relay contacts 1 and 2 out of the circuit. Operation of the K3 relay contacts 4 and 5 will complete the 115 v ac circuit to the buzzer causing it to sound.

(b) With the connect circuit on, the collector of Q6 will be near neutral. This causes the timer to start. At the end of a 2.3 second period, a positive pulse from the timer is coupled to the base of Q9 through C10 and CR17. This pulse will cause the local circuit to turn off. The LOCAL lamp will go out and K3 will release. The K3 contacts 1 and 2 will short the signal loop through the keyboard distributor and selector. The K3 relay contacts 4 and 5 will open and the buzzer will turn off. The teletypewriter is now in the connect condition.

POLAR ADAPTER

A. General

3.38 The following description is based upon schematic wiring diagram 5923WD.

3.39 The polar adapter converts the types of signals received from the receiving leg and the teletypewriter into those usable by the circuitry and the sending leg. Some of the functions of the relay contacts are modified by the polar adapter, but they serve the same general purpose. The outward operations of the call control unit, with the polar adapter attached, are identical to those of the call control unit alone.

3.40 The polar adapter consists electrically of four basic parts. These parts are:

(a) Receiving polar relay: This relay converts the received signals into those usable by the circuitry of the adapter and the call control unit.

(b) **Sending polar relay:** This relay converts the make-break signals generated by the distributor into transmitted line signals.

(c) **Connect control timer:** This circuit is made up of four basic parts and differentiates between control and information signals.

(d) **Current amplifier:** This circuit amplifies the signals of the receiving polar relay to control the selector magnet driver.

3.41 The polar adapter operates on a 3-wire basis. Two of these wires are the sending and receiving legs. The third wire is an earth return for these two legs. The polar adapter will, therefore, not operate unless earth ground is supplied. The chassis of the polar adapter is grounded to the power supply. When installed in the call control unit, electrical connection is made through the chassis contact to the third wire in the power plug. This third wire in the power cord must be connected to a suitable earth ground.

3.42 The sending and receiving polar relays are of the nonbridging mercury-wetted contact type. They are housed in metal cylinders with an 11-pin tube socket at their base. Because of the mercury in the relay capsule, they must be operated within 30 degrees of vertical to prevent shorting of the contacts.

(a) The coils of the polar relay are as follows:

Pins no. 2 and 11 - Drive coil
 Pins no. 3 and 10 - Drive coil
 Pins no. 5 and 9 - Bias coil
 Pins no. 6 and 8 - Bias coil
 Pins no. 1 and 7 - Contacts
 Pin no. 4 - Tongue

(b) In the polar adapter, contact no. 7 has been chosen as the spacing contact and contact no. 1 as the marking contact. To close contact no. 1 and the tongue, current must flow from either pins no. 2 to 11, 3 to 10, 9 to 5, or 8 to 6.

3.43 All polar relay contacts are protected by arc suppressors. These arc suppressors slow the rate of change of voltage across the mercury-wetted contacts of the polar relays. On the receiving polar relay the arc suppressors are made up of R32, R33, C5, and C6. On the sending polar relay they are made up of R43, R44, C7, and C8.

3.44 All voltage sources are isolated by at least 120 ohms. In the event of a momentary short, current through the polar relay contacts or the connectors is limited to 1 ampere or less. If a short is of long duration, the resistor will act like a fuse and open the shorted circuit. These resistors are R34, R36, R38, R41, and R42.

3.45 When polar signals are being transmitted by the sending polar relay, a noise suppressor is used in the sending leg. This suppressor consists of a "pi" filter and is made up of C11A, C11B, and R45. The filter rejects all high frequency components of the transmitted signal. It is not used when neutral signals are transmitted.

B. Receiving Polar Relay

3.46 This polar relay and its associated components convert incoming signals into those usable by the circuitry of the polar adapter and the call control unit.

3.47 Several types of input signals to this polar relay are possible. These modes of operation may be selected by appropriate strapping of the binding posts on the TP181607 printed card assembly. The various modes of operation are:

(a) Polar signals, battery supplied remotely. This is the normal mode of operation, and all polar adapters are supplied with strapping for this type of operation.

(b) Neutral signals, battery supplied by the polar adapter. In this condition, posts no. 3 and 4, 5 and 7, and 12 and 13 are strapped together.

(c) Neutral signals, battery supplied remotely (battery negative). In this condition, posts no. 5 and 12, 6 and 13, and 3 and 4 are strapped together.

(d) Neutral signals, battery supplied remotely (battery positive). In this condition, posts no. 3 and 4, 12 and 13, and 5 and 6 are strapped together.

3.48 With the wiring as described in 3.47, a spacing signal will cause the tongue (4) of the polar relay to rest on the space contact (7). With a marking signal, the tongue will rest on the mark contact (1). The tongue (4) of the polar relay is supplied with +120 volts through R34. It supplies this voltage to the selected contact, while the other contact has no potential applied. Both contacts have two outputs. One of these is a voltage or direct output, while the other is current output. The current output is through a diode and a resistor and will supply approximately 0.010 ampere to ground. The diode prevents reversed currents from flowing when the contact is not supplied with +120 volts from the tongue. The output diodes and resistors are CR11, CR12, R30, and R31.

3.49 The bias for this relay, when used in neutral operation, is 0.030 ampere and is supplied through R37 and strapped terminals no. 3 and 4. Operating current for neutral operation, when supplied locally, is supplied from -120 volts and is limited to 0.060 ampere by R46 and the signal line resistance.

C. Sending Polar Relay

3.50 This polar relay converts the neutral make-break signal generated by the distributor and the dial into those required on the sending leg. There are a variety of possible signal types that can be transmitted. These are:

(a) Polar signals, battery supplied by the polar adapter.

This is the normal mode of operation and all polar adapters are supplied with strapping for this type of operation.

(b) Neutral signals, battery supplied by the polar adapter. In this condition, posts no. 10 and 11 are strapped together, and the straps between posts no. 8 and 9, 14 and 15, and 16 and 17 are cut.

(c) Neutral signals, battery supplied remotely. In this condition posts no. 6 and 10 are strapped together, and straps between posts no. 8 and 9, 10 and 11, 14 and 15, and 16 and 17 are cut.

(d) Since both the drive and bias windings are wired in series, both windings are supplied with the same amount of current. The input current of 0.021 ampere to the drive windings is supplied through R40 from +120 volts. The 0.021 ampere to the bias is supplied through R39 from +120 volts.

D. Connect Control Timer

3.51 This circuit consists of four basic parts on the TP181606 assembly. These are: a strobe pulse generator, two timing transmission gates, and binary.

3.52 The strobe pulse generator generates a 120 Hz square wave. This square wave and the outputs from the receiving polar relay are used as inputs to the two timing transmission gates. The outputs of these two gates are used to control the binary. The output of the binary, in turn, is used to control the connect circuit in the call control unit.

3.53 The strobe pulse generator is made up of Q1 and Q2 and associated components. It is controlled and caused to oscillate by alternating current from the power transformer of the call control unit. This 12.5-volt ac (18-volt peak) sine wave is rectified by CR1 and CR2 to form a negative 120 Hz wave. The base of Q1 is biased by R2 and R3 such that -3.9 volts is necessary at the junction of CR1 and CR2 to turn on Q1. When base current does flow to Q1, it will turn on, and its collector will become nearly ground. R4 and R5 form a voltage divider which back-biases the base of Q2 and holds it off. The voltage at the collector of Q2 will be set by a voltage divider made up of R8 and R9. This voltage is -9.1 volts. Feedback, through R6 from the collector of Q2 to the base of Q1, will help provide snap-action.

3.54 When the 120 Hz sine wave becomes more positive than -3.9 volts, base current to Q1 will cease to flow. The collector of Q1 will now have a potential of -5.7 volts. Current will now flow through R5 to the base of Q2 and cause the transistor to turn on. The collector of Q2 will now be very close to a neutral potential. This circuit will continue to oscillate as long as power is applied to the control unit transformer.

3.55 Two, 1-percent tolerance resistors (R8 and R9) in the collector of Q2, set the voltage at that point at -9.1 volts. This voltage level is important in controlling the binary and setting the proper time delay intervals in the timing gates. The square wave generated at the collector of Q2 will be ground for approximately 0.0013 second and -9.1 volts for approximately 0.007 second.

3.56 When spacing signal is present on the receiving leg, +120 volts is applied to contact no. 7 and no voltage is applied to contact no. 1 of the receiving polar relay. No voltage will appear across R28, and the voltage at the junction of R28 and R26 is set by current flow through CR10 and R26. This voltage will be approximately -60 volts. CR8 will conduct and the voltage across C3 and at the anode of CR5 will be held at -60 volts. If Q4 is in conduction, its base will be nearly ground, and CR5 will be back-biased by 60 volts.

3.57 The 9.1 volt strobe pulse introduced at C1 will cause the voltage at the anode of CR5 to rise to -50.9 volts. The negative pulse, that follows in 0.0013 second will lower it to -60 volts. The net result of these strobe pulses upon the voltage on C3 is, therefore, zero, and CR5 is not forward-biased at this time.

3.58 When a marking signal appears on the receiving leg, a positive potential of 120 is applied to one side of R28 through the marking contacts of the receiving polar relay. The voltage divider of R26 and R28 will have a +22 volt potential at its junction and reverse-bias CR8. This action will isolate C3 from R26 and R28 and it will begin to discharge through R20 from a -60 volt potential toward ground. The anode voltage of CR5 will respond to the discharging, reducing its reverse-bias condition. After approximately 0.08 second the voltage on C3, and therefore the anode of CR5, will have risen to -9.1 volts. The next strobe pulse to appear at C1 will cause CR5 to become forward-biased, and part of the pulse will appear at the base of Q4.

3.59 The gate just described is the connect timing gate and produces a signal delay of approximately 0.08 second. The disconnect timing gate operates in a similar manner. The input to R27 is from the spacing contact. When mark appears on the receiving leg, R25 and CR9 hold the voltage on C4 at -60 volts. When a spacing signal appears, CR7 will be back-biased, and C4 will discharge through R19

from -60 volts toward ground. In approximately 1.3 seconds the voltage across C4, and therefore at the anode of CR4, will become more positive than -9.1 volts. The next strobe pulse introduced across C2 will cause CR4 to be forward-biased, and part of the strobe pulse will appear at the base of Q3.

3.60 C3 will recharge to -60 volts from -9.1 volts in 0.004 second. C4 will recharge in 0.01 second. Both of these recharge times are less than one code element length and can be considered instantaneous.

3.61 The outputs of the transmission gates control the binary which is made up of Q3 and Q4 and associated components. The operation of this binary is similar to that of the binaries in the call control unit. The control of the binary by the transmission gates is the same as that of the 2.3-second timer controlling the local circuit in the call control unit. A positive pulse at the base of Q4, through CR5, will turn off Q4 and turn on Q3. The collector of Q3 will then be near ground. Current will flow through R35 and through ZD1 to the collector of Q3. The cathode of

ZD1 will be +9.1 volts with respect to its anode, so that the voltage at the cathode will be +9.1 volts. This point is the output to the connect circuit of the call control unit.

3.62 A positive pulse at the base of Q3 through CR4 will turn off Q3 and turn on Q4. The collector of Q3 will go negative. Current flow through CR6 and R23 will hold this voltage to -18 volts. Current flow through R35 and ZD1 will hold the voltage at the cathode of ZD1 to +9.1 volts of -18 volts. The output will then be -8.9 volts. A negative output (Q3 off) will hold the connect circuit of the call control unit off, and a positive output (Q3 on) will hold the connect circuit on.

E. Current Amplifier

3.63 This circuit is made up of Q5 and associated components on the TP181606 assembly. Base current to this amplifier is supplied through CR12 and R31 from the marking contact of the receiving polar relay.

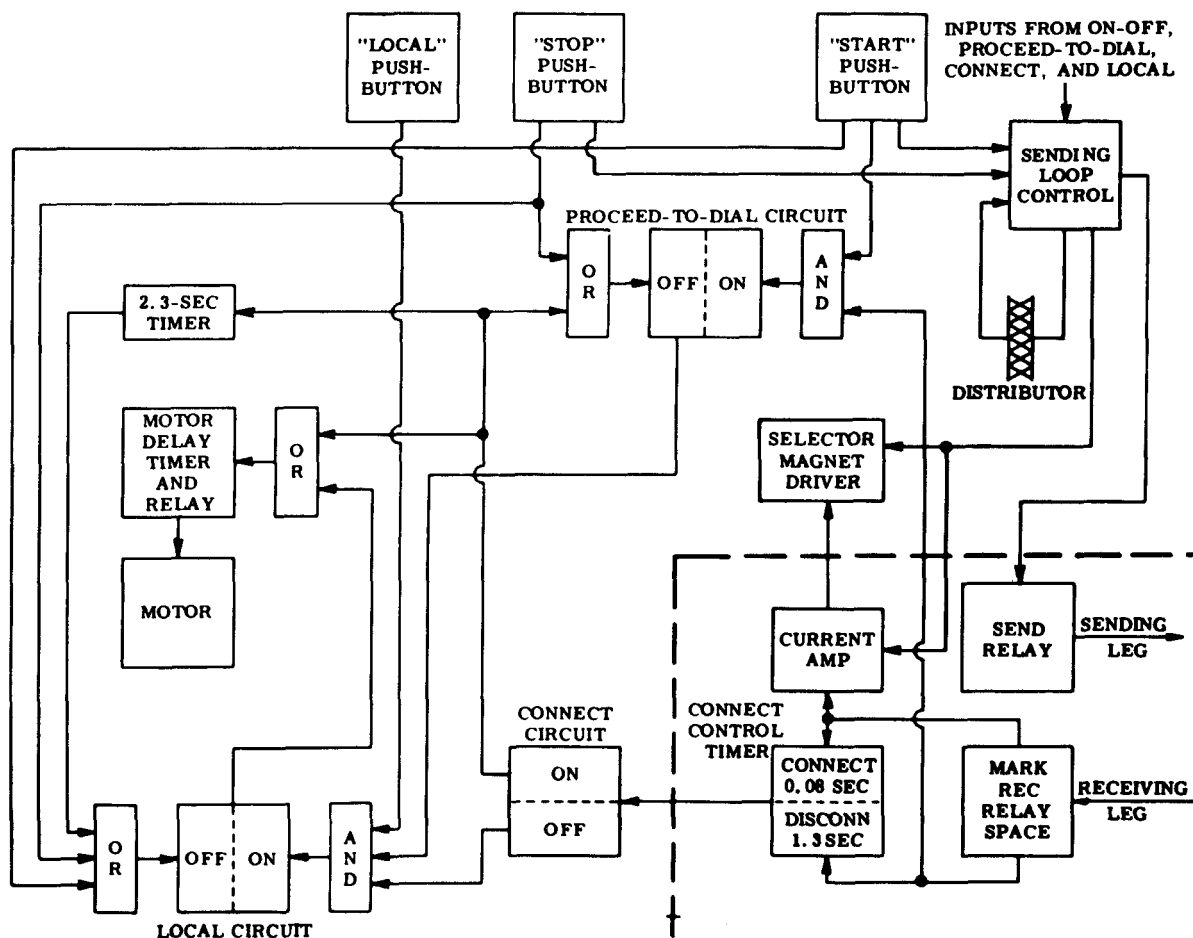

Figure 10 - Polar Adapter Circuit

3.64 If ground is applied to the emitter of Q5 through CR3 or by strapping binding posts no. 1 and 2, the base is reverse-biased by the voltage divider made up of R13 and R14. If base current is now supplied, the transistor will turn on. With the collector load as shown in Figure 12, 0.060 ampere of collector current will flow.

3.65 If the ground to the emitter of Q5 through CR3 is switched to +120 volts, CR3 will become back-biased. The emitter is biased to near +18 volts through R12. Since both the emitter and collector are biased to +18 volts, no current will flow between them. Base current supplied to the transistor will flow into both the collector and emitter. The current in the collector will flow from the base, through the collector, the selector magnet driver, and R23 to +18 volts. This current flow is in the reverse direction of the normal control current for the selector magnet drive, and it will be held spacing.

3.66 The amplifier will supply marking current only when ground is applied to the emitter, and the base current is supplied. If either of these conditions is not fulfilled, the selector magnet driver will not be supplied input current, and its output will be spacing.

3.67 Strapping posts no. 1 and 2 will permanently apply ground to the emitter and allow duplex operation of the teletypewriter.

F. Circuit Interconnections

3.68 Figure 10 is a block diagram showing the polar adapter connected to the call control unit. The call control unit portion of the block diagram is the same as that shown in Figure 7 with one exception. The line sensing and control block of the call control unit is now called the sending loop control. All of the components are identical in these two blocks, but rewiring allows the block to control the sending leg rather than the signal loop. This block also has outputs to the current amplifier and the selector magnet driver. The input to the current amplifier allows the teletypewriter to read its own copy. The input directly to the selector magnet driver is for teletypewriter blinding.

3.69 The receiving polar relay marking contact supplies inputs to both the connect control timer and the current amplifier. The input to the current amplifier allows the teletypewriter to read incoming copy. The input to the connect control timer allows the polar adapter to recognize a connect signal. The spacing contact supplies inputs to both the connect control timer and the proceed-to-dial circuit of the call control unit. The input to the connect control timer allows the polar adapter to recognize a disconnect signal. The input to the proceed-to-dial circuit supplies current for spacing signals and no current for mark. This allows this circuit to operate in the normal manner.

G. Idle Line Condition

3.70 In this condition both the sending and receiving legs are spacing. All the circuits in the call control unit are off. The spacing contact of the receiving polar relay is +120 volts and allows C4 to be discharged. CR4 will then allow strobe pulses to pass to the base of Q3 and hold it off. The output of the connect control timer is then negative and holds the connect circuit in the call control unit off.

3.71 Figure 11 is a schematic wiring diagram of the sending loop control circuit with the current amplifier and the sending polar relay. Blinding current to the selector magnet driver flows from +18 volts through R23, J5-2, the selector magnet driver, J4-3, and "hl" contact, the "wl" contact, J4-9, and the distributor to ground. No current flows in the drive coils of the sending polar relay, since neither the start contact, the "a" contact, nor the "hl" contact are operated to supply ground.

3.72 The marking contact of the receiving polar relay has no voltage applied. No base current will then flow from this contact to Q5. The emitter of Q5 is biased to +18 volts through R12. The cathode of CR3 is at +120 volts which is supplied through R39 and the sending relay coils, and CR3 is back-biased.

H. Initiating a Call

3.73 A call may be initiated when the call control unit is in either the idle line or local conditions as described earlier. Depressing the START pushbutton will allow current to flow through the drive coils of the sending polar relay. This sending polar relay will then transmit a marking signal on the sending leg. The current path through the coils is shown by the dotted line in Figure 11.

3.74 Operating the START pushbutton will also remove ground from the collector of Q1 in the call control unit. Current to the input of the proceed-to-dial circuit (base of Q1) is supplied from the spacing contact of the receiving polar relay. This is not shown in Figure 11. The proceed-to-dial circuit will not operate until this current is interrupted.

I. Proceed-to-Dial

3.75 The exchange will recognize the marking signal transmitted as a request to dial. When the exchange has selected the proper equipment, it will transmit a 0.025 second marking signal on the receiving leg. The receiving polar relay will respond to this signal by interrupting the current flow to the input of the proceed-to-dial circuit. This circuit will then turn on, and energize the (K1) relay and the proceed-to-dial lamp. The "a" contact will operate and shunt out the START pushbutton contact. The START pushbutton may now be released.

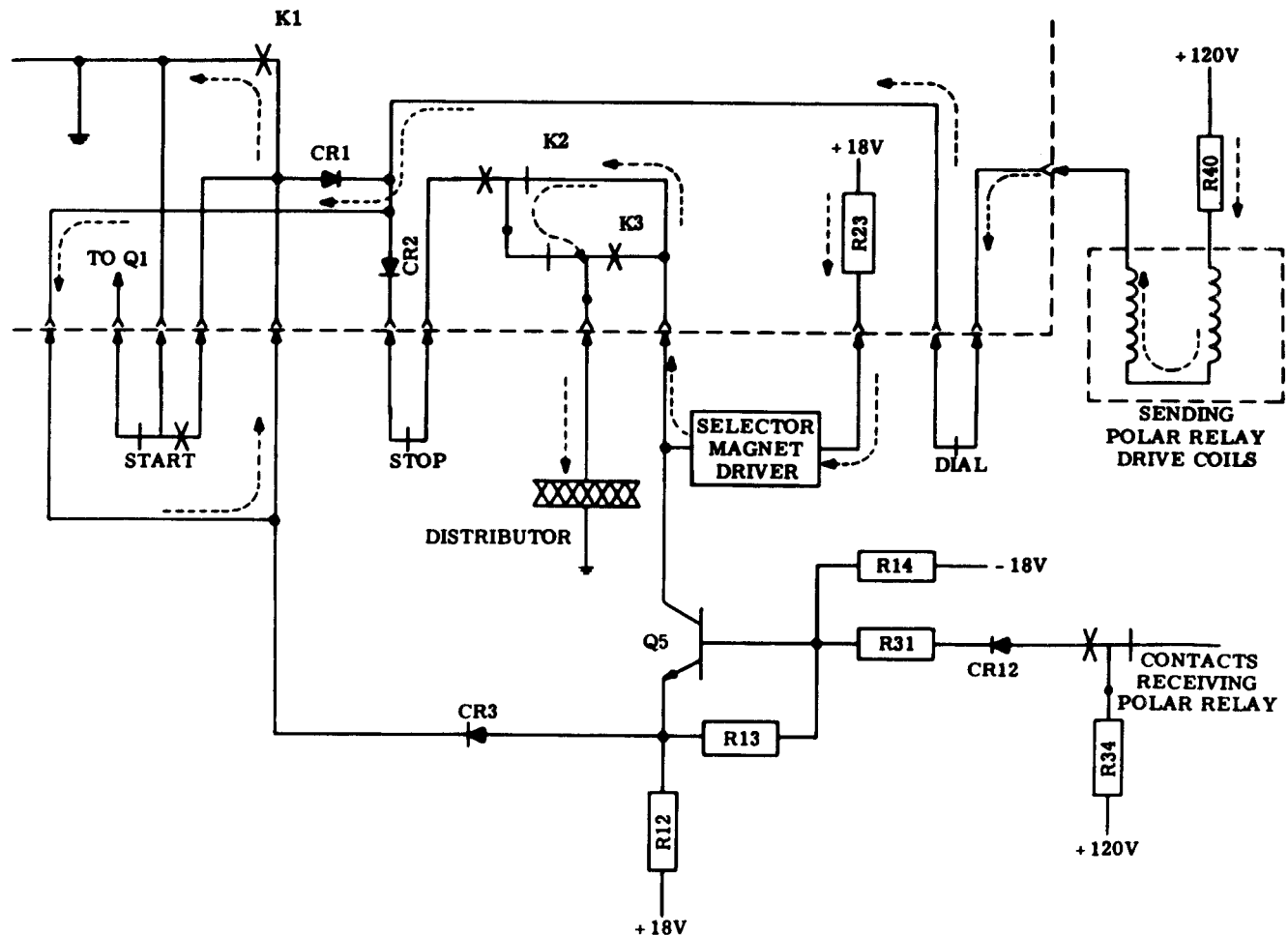

Figure 11 - Sending Loop Control Circuit With Sending Polar Relay

3.76 When the receiving polar relay responds to the 0.025 second pulse, C3 in the connect control timer will start to discharge. After 0.025 second the receiving leg returns to spacing and causes C3 to be recharged to -60 volts. In the 0.025 second interval, the voltage across C3 will not rise to -9.1 volts, and no strobe pulse will be passed by CR5. The connect control timer, therefore, will not respond to a proceed-to-dial pulse.

J. Dialing

3.77 The dial signaling contacts are in series with the drive coils of the sending polar relay as shown in Figure 11. The dial contacts will thus energize and de-energize this relay whenever current is flowing through them. The make-break signal generated by the dial contacts will be transmitted as mark-space signals by the sending polar relay. These mark-space signals are used by the exchange to make the necessary connection.

K. Call Connection

3.78 With the call control unit in the proceed-to-dial condition, the sending leg is marking, and the receiving leg is spacing. When dialing is completed, the exchange will switch the receiving leg to marking. This signal causes the tongue of the receiving polar relay to transfer and apply +120 volts to R28. CR8 will become reverse-biased, and C3 will begin to discharge toward ground. After 0.080 second, the voltage across C3 will be approximately -9.1 volts. The next strobe pulse to appear will pass through CR5 to the base of Q4. The output of the connect control timer will then become positive and cause the connect circuit to turn on. As described earlier, the proceed-to-dial circuit will turn off. As the connect circuit turns on, the (K2) relay will operate, the "hl" contacts will transfer, the CONN lamp will light, and the motor will turn on.

3.79 Current flow to the drive coils of the sending polar relay is now through R40, the drive coils, the dial contacts, CR2, the stop contacts, K1, K2, and the keyboard

contacts to ground as shown in Figure 12. Base current to Q5 is now supplied from the marking contact of the receiving polar relay through CR12 and R31. Input current to the selector magnet driver will flow from +18 volts through R23, the selector magnet driver, Q5, CR3, CR2, the stop contacts, K1, K2, and the distributor contacts to ground.

3.80 Both the current paths for the drive coils of the sending polar relay and the selector magnet driver are through the distributor contacts. If the distributor is operated, the signal will be transmitted on the sending leg and cause the selector magnet of the teletypewriter to operate. When information is received from the distant station, the receiving polar relay will operate and make or break base current to Q5. This will cause Q5 to make or break current flow to the selector magnet driver without affecting the sending circuit.

3.81 The longest possible normal spacing signal generated by the distant teletypewriter will be less than 1.3 seconds. This is the length of spacing signal required

to cause the connect control timer to disconnect. Therefore, under normal signaling, the connect control timer will not be affected by information signals.

L. Remote Connection

3.82 The call control unit may be connected remotely from either the idle line or local condition. An incoming call is indicated by the exchange by its transmission of a marking signal on the receiving leg. The connect control timer after 0.080 second, will turn on the connect circuit in the control unit. A current path to ground is set up through the drive coils of the sending polar relay. It will then transmit a marking signal on the sending leg to signify that the unit has connected. The remainder of the operations are the same as described in 3.78 through 3.81.

3.83 If the paper in the teletypewriter has become low and the low-paper contacts operate, the voltage across C3 will be held at -60 volts through R29. This will stop any connections from occurring. If the call control unit is

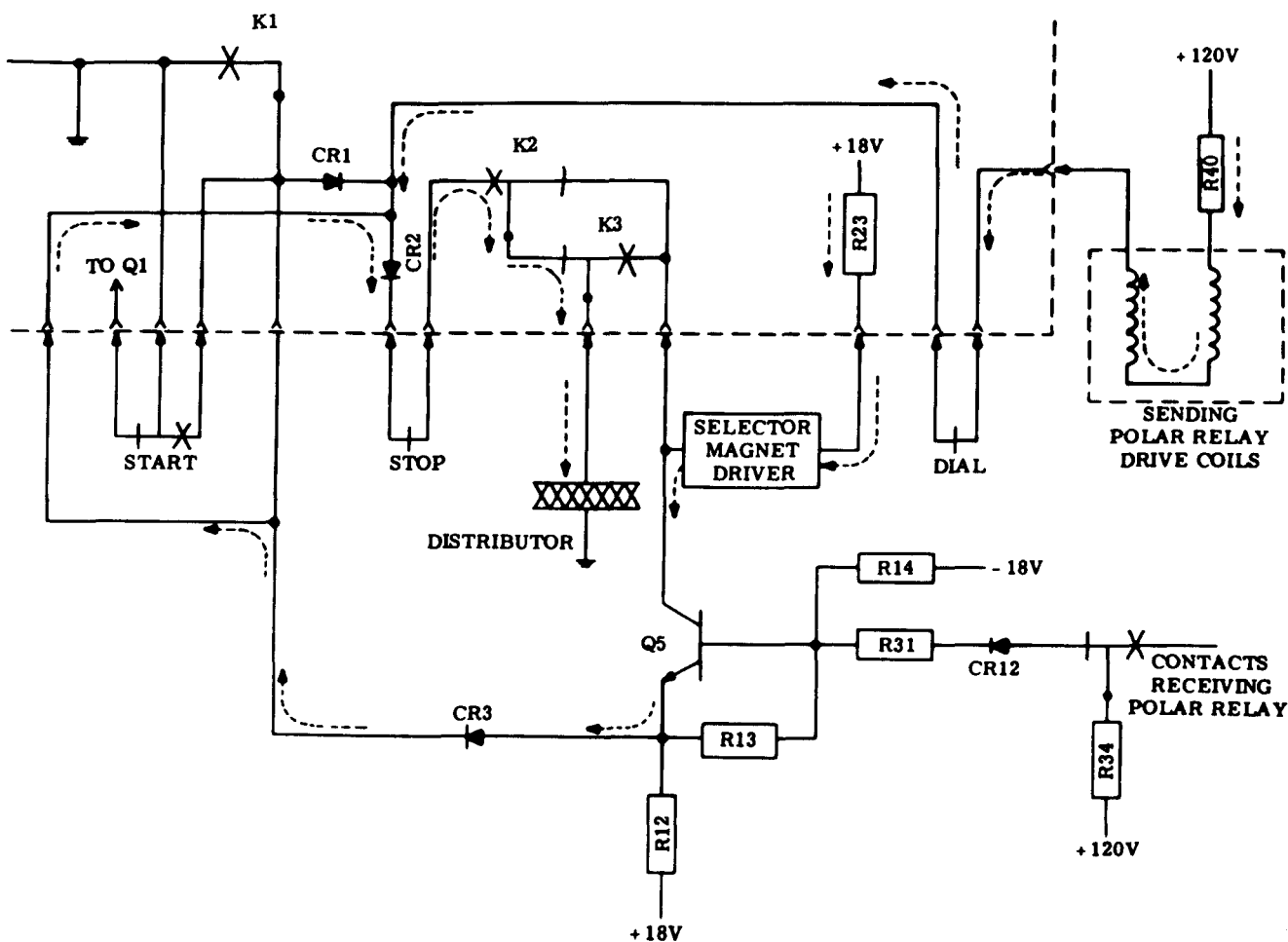

Figure 12 - Receiving Loop Control Circuit With Receiving Polar Relay

already in the connect condition, when the low-paper contacts close the call may be completed, but subsequent connections will be blocked.

3.84 If a call is originated locally with a low-paper condition, the normal sequence of events will occur until the connection is attempted. When the exchange does not receive a marking signal on the sending leg, it will turn the receiving leg to spacing (idle line condition).

M. Call Disconnect

3.85 If the STOP pushbutton is depressed while the teletypewriter is in the connect condition, the stop contacts in series with the drive coils of the sending polar relay will open. The relay output will then be spacing. The exchange will recognize this long spacing signal as a request to disconnect and will send a spacing signal on the receiving leg. The receiving polar relay contacts will transfer and allow C4 to discharge toward ground. After 1.3 seconds, the voltage across C4 will be -9.1 volts, and the next strobe pulse will pass through CR4 to the base of Q3. The output of the timer will become negative and turn off the connect circuit in the call control unit. Current to the drive coil of the sending polar relay will be held off so that the STOP pushbutton may be released. The K2 contacts will now also supply blinding current to the selector magnet driver. The control unit is now in the idle line condition.

N. Remote Disconnect

3.86 When the remote unit generates the spacing signal to disconnect, the receiving polar relay will allow C4 to discharge and after 1.3 seconds the timer will turn off the connect circuit. The K2 contacts will transfer, stopping current flow to the drive coils of the sending polar relay and blinding the selector magnet driver. The call control unit is now in the idle line condition.

O. Local Off-Line Operation

3.87 This operation is identical to that of the call control unit without polar adapter except for the current path to the selector magnet driver. This path is shown in Figure 11.

4. PRIVATE WIRE SERVICE

INTRODUCTION

4.01 Power for the motor, selector magnet driver, local power supply, and tape reader power pack, when provided, is supplied from fused 115-volt ac, 60 Hz power. Direct current of either 0.020 or 0.060 ampere is required for the signal line(s) and for operation in the local mode. Battery for the signal line(s) is supplied by the customer's facilities, while local battery for operation in the local mode is

furnished through the operation of the local power supply circuit in the call control unit. At the rear of the call control unit is a terminal strip which provides the point of entry for the ac power and the signal line(s) into the teletypewriter.

4.02 The purpose of the selector magnet driver is to amplify received dc marking and spacing intelligence pulses. Received dc intelligence pulses are directed to the input of the selector magnet driver circuit in the call control unit where they are amplified and returned as 0.500 ampere dc intelligence pulses to operate the typing unit selector. A detailed description of the operation of a selector magnet driver is given in 2.92 through 2.102. The selector magnet driver described there is similar to the ones used in private wire service.

A. Power Switch and Local Power Supply Circuits

4.03 The 3-position rotary switch (electronically shown in Figure 13) is the only manual control on the call control unit. Through its operation the teletypewriter can be (1) placed in the external signal line loop for communication with other teletypewriters, (2) removed from the external signal line loop for local operation, or (3) placed in the off condition.

B. Mode Chart

4.04 The following chart indicates the condition of the rotary power switch contacts — either open or closed — when the control knob is turned to one of its positions:

KNOB POSITION	LINE SEGMENT		CONTACTS CONDITION
	FROM	TO	
LINE	L1	2	Closed
	L1	1	Closed
	L2	2	Open
LOCAL	L1	2	Closed
	L1	1	Open
	L2	2	Closed
OFF			All Open

OFF MODE

A. Power Circuit

4.05 All power in the call control unit, except that applied to the selector magnet driver is off.

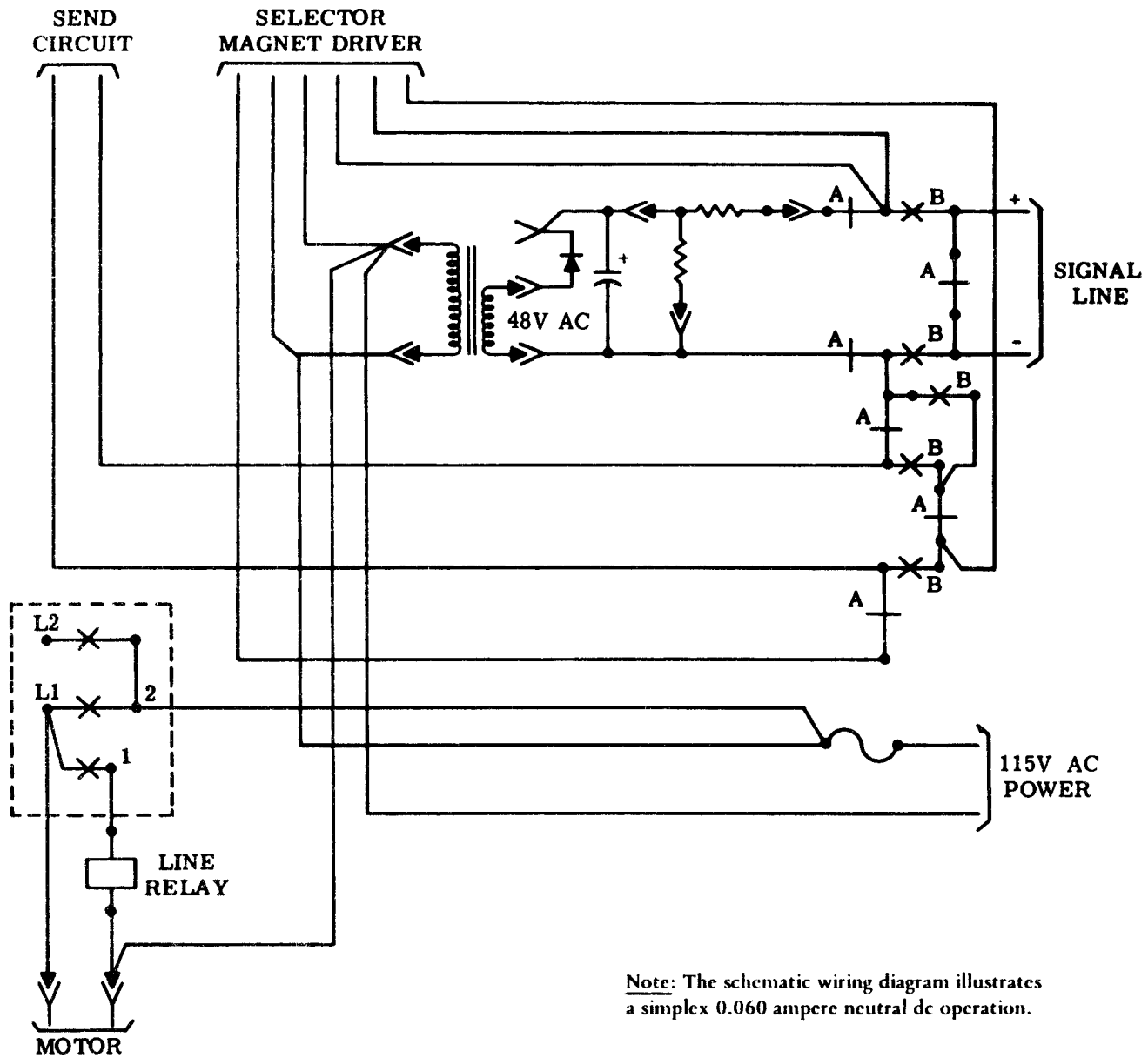

Figure 13 - Rotary Power Switch and Local Power Supply Circuit

B. Signal Circuit

4.06 The signal line is diverted around the local teletypewriter so other teletypewriters in the external signal line loop can communicate without interference.

LOCAL MODE**A. Power Circuit**

4.07 The line relay is not energized and the local battery is supplied to the selector magnet driver and the send circuit.

B. Signal Circuit

4.08 The normally closed contacts A remain closed, and the normally open contacts B remain open. The external signal line loop is divorced from the selector magnet driver, and shunted so that other teletypewriters in that loop can communicate without being affected by the operation of the local teletypewriter.

LINE MODE**A. Power Circuit**

4.09 The line relay is energized and the battery is on the signal line.

B. Signal Circuit

4.10 The normally closed contacts A will open and the normally open contacts B will close. The external signal line loop is united with the selector magnet driver and the local teletypewriter can now communicate any other teletypewriters in that loop.

4.11 Any transmission from the keyboard or tape reader, if provided, will cause the typing unit distributor to send start-stop signals to other teletypewriters in the external signal line loop. Also, the local teletypewriter is able to receive the start-stop signals transmitted from other teletypewriters in the same external line loop.

33 TELETYPEWRITER SET

INSTALLATION

CONTENTS	PAGE
1. GENERAL	1
UNPACKING	1
PREPARATION FOR INSTALLATION	2
2. INSTALLATION	3
MOUNTING TYPING UNIT ON STAND	3
CODING ANSWER-BACK DRUM	3
ELECTRICAL CONNECTIONS AND PRE-SERVICE PROCEDURES	8
PLACEMENT	12
A. Without Stand	12
B. With Stand	12
3. FINAL ASSEMBLY	12
GENERAL	12
RIBBON INSTALLATION	12
PAPER OR FORM INSTALLATION	12
A. Friction Feed	12
B. Sprocket Feed	14
4. TAPE READER	15
5. POWER PACK ASSEMBLY	15
6. TAPE PUNCH	17
7. RESHIPMENT	18
8. OPTIONAL FEATURES	20
A. Copyholder	20
B. Busy Circuit	20
C. Hand Receiver	20

1. GENERAL

1.01 This section provides installation instructions for the 33 teletypewriter set. It is reissued to include 3300 Series Coded Sets and Computer Input/Output Sets. Some minor changes have been made throughout the section, as well as some additions and rearrangement of text. Marginal arrows have not been used to indicate the changes or additions.

1.02 References to left, right, front, or rear, etc, consider the teletypewriter set to be viewed from a position where the typing unit carriage faces up and the typing unit selector mechanism is located to the viewer's left.

1.03 Tools and materials used for teletypewriter set installation are shown in Section 570-005-800TC.

Note: To avoid injury, take special care when working with a teletypewriter set connected to its power supply.

1.04 Leads for the signal line must be furnished by the customer.

UNPACKING

1.05 The teletypewriter set is packed in one carton. Observe all caution and instruction labels on the carton before breaking the seals.

1.06 Cut tape at center and end seams. Open carton and remove the upper filler pads. Remove typing unit carefully to avoid damaging the plastic cover. Take out the remaining carton fillers and the stand (if used).

1.07 The typing unit and subbase are mounted on a shipping pallet by six screws. Remove the six screws, being careful that the typing unit does not fall off the pallet. Once the shipping screws are removed, the typing unit is retained only by the cover.

Note: Retain the forward mounting screw and associated flat washer. This screw is used to secure the typing unit when shipped to another location without its cover fastened in place. The screw and washer may be stored in the TP181104 cable clip (included in bag of hardware with pedestal mounted units) to be mounted on the typing unit frame between the two dashpot mounting screws (Figure 1).

- 1.08 Remove typing unit from the shipping pallet.

CAUTION: DO NOT TILT THE TYPING UNIT AFTER IT HAS BEEN REMOVED FROM THE PALLET. THE TYPING UNIT FLOATS ON RUBBER ISOLATORS AND MAY PULL LOOSE IF IT IS TILTED.

PREPARATION FOR INSTALLATION

- 1.09 Remove the tape from across the top of the cover and take out the cables, platen knob, and paper spindle from the paper recess. Unwrap the parts.

- 1.10 Remove the call control bezel, if used, after removing its two mounting screws. Remove volume control knob or power switch rotary knob, if used, by pulling knob forward. Detach the nameplate (Figure 2) by pulling it down and out. Remove the four front and three rear cover mounting screws.

Note: On Automatic Send-Receive (ASR) Sets, remove the screw from the left rear corner of the tape reader cover.

Gently lift the cover from the subbase.

- 1.11 Remove the twist tie holding the carriage to the left side frame of the typing unit.

- 1.12 If a stand is used, remove its two rear panel mounting screws and take panel off. Remove the copyholder, if used, from inside the stand. Remove the bag tied to the stand and place its hardware contents on the bench.

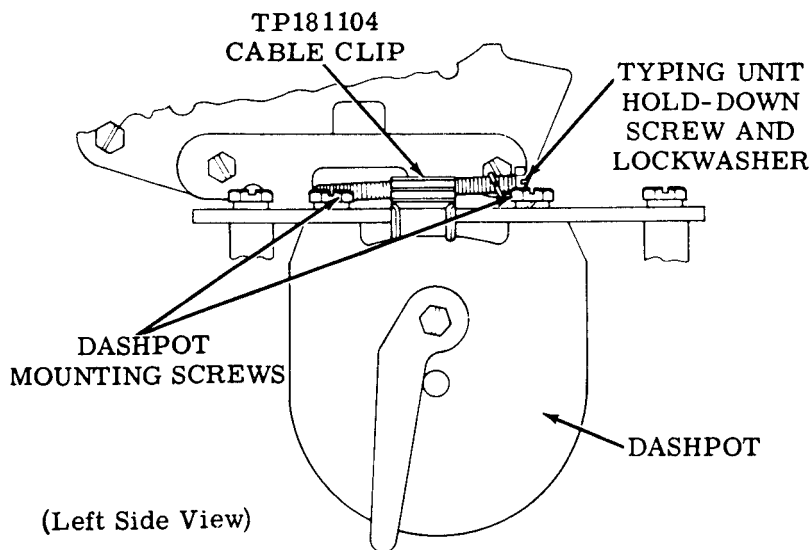

Figure 1 - Typing Unit Hold-Down Screw Storage

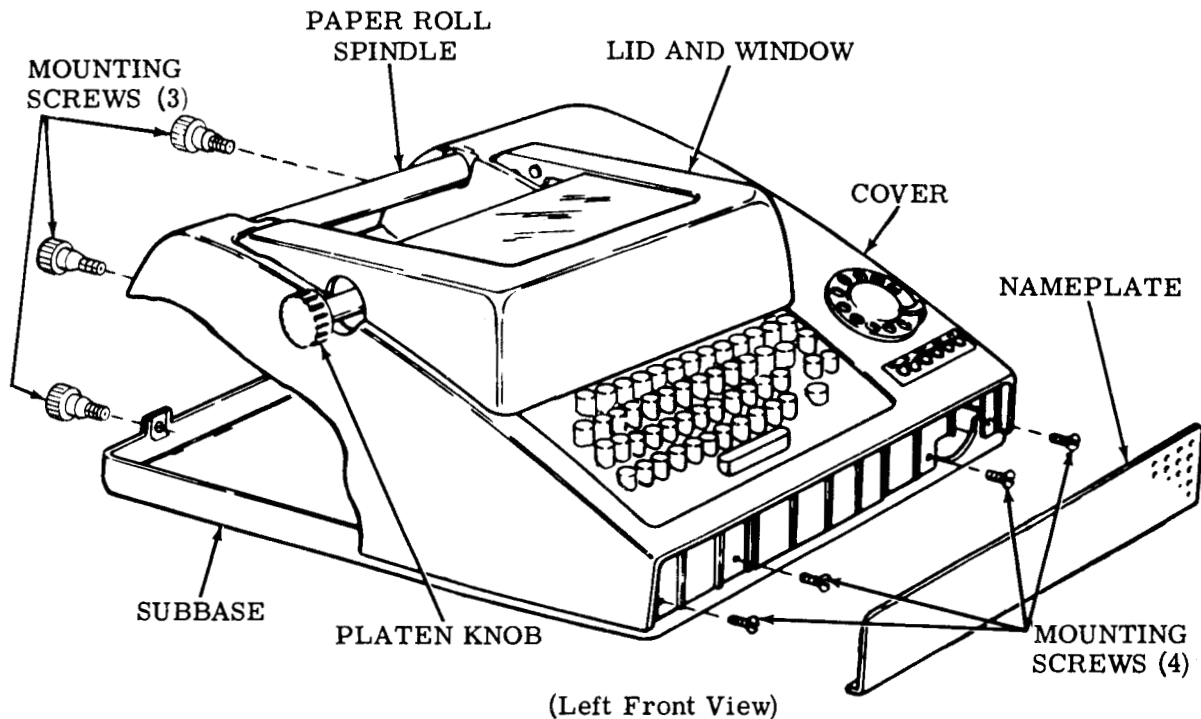

Figure 2 - Cover Mounting

1.13 Use the supplied screws to fasten the data set, if used, to the relay rack.

1.14 The teletypewriter set should be thoroughly lubricated before placing it into service and relubricated after a short period of service. Thereafter, maintain the regular lubrication intervals as required in the appropriate lubrication sections.

2. INSTALLATION

MOUNTING TYPING UNIT ON STAND

2.01 If the teletypewriter set is to be bolted to the floor, remove the front screw in each leg of the stand (Figure 3).

2.02 Install the plug button, included in the bag of hardware, in the forward hole in the bottom of the subbase.

2.03 Place the subbase and typing unit on top of the stand so that its back edges and sides line up with the back edges and sides of the stand. Install the two retaining clips, included in the hardware bag, on the base at the rear (one each end) and snap them in place on the stand. Refer to Figure 4.

2.04 Mount the base to the stand from the bottom with four no.14Z screws and associated flat washers.

CODING THE ANSWER-BACK DRUM

2.05 To remove answer-back drum for coding, press back and down on the tab portion of the TP180854 brace until it becomes detented in its open position. Lift feed pawl slightly (do not overextend its spring) and remove drum.

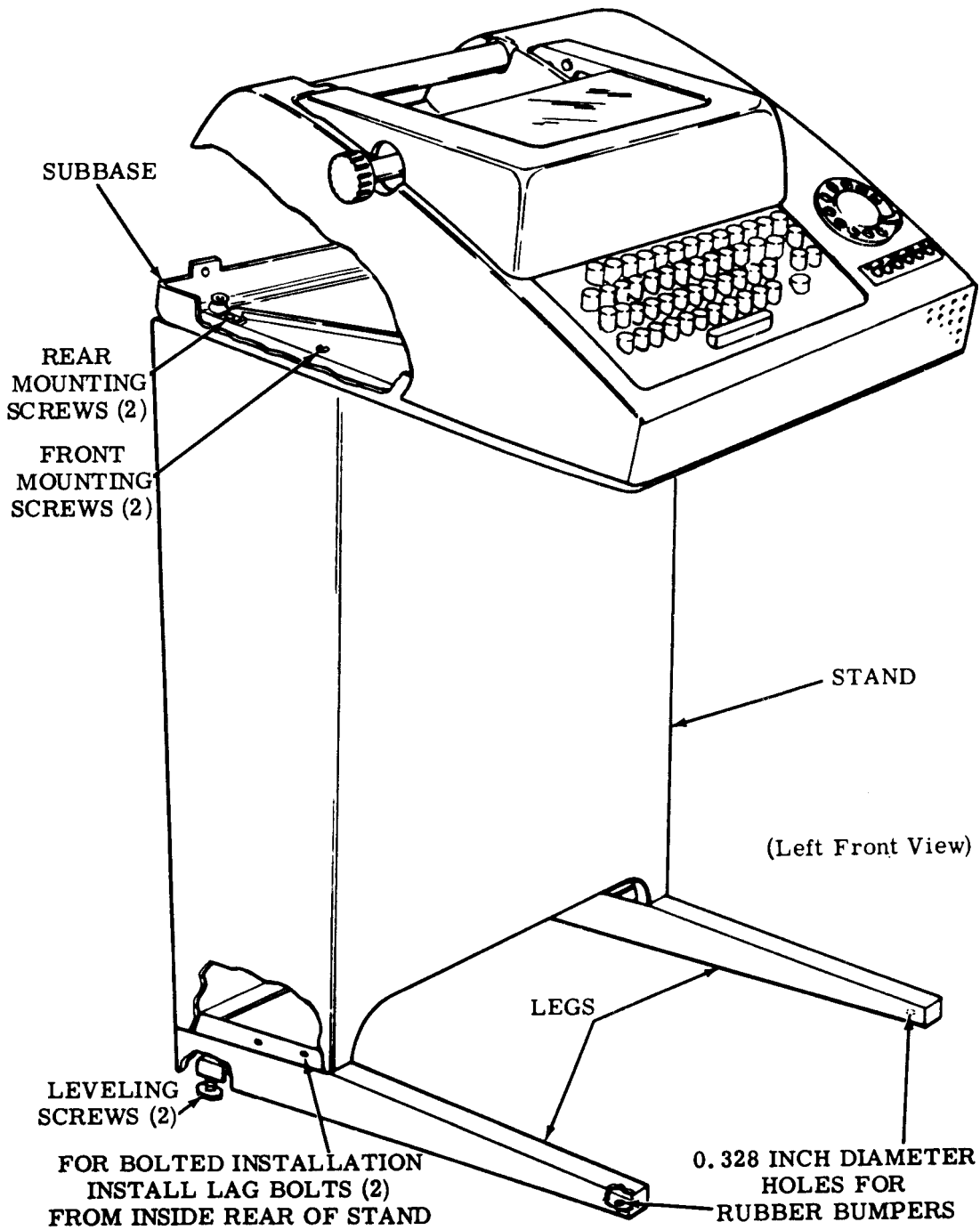

Figure 3 - Stand Leveling and Anchoring and Assembly of Subbase with Typing Unit to Stand

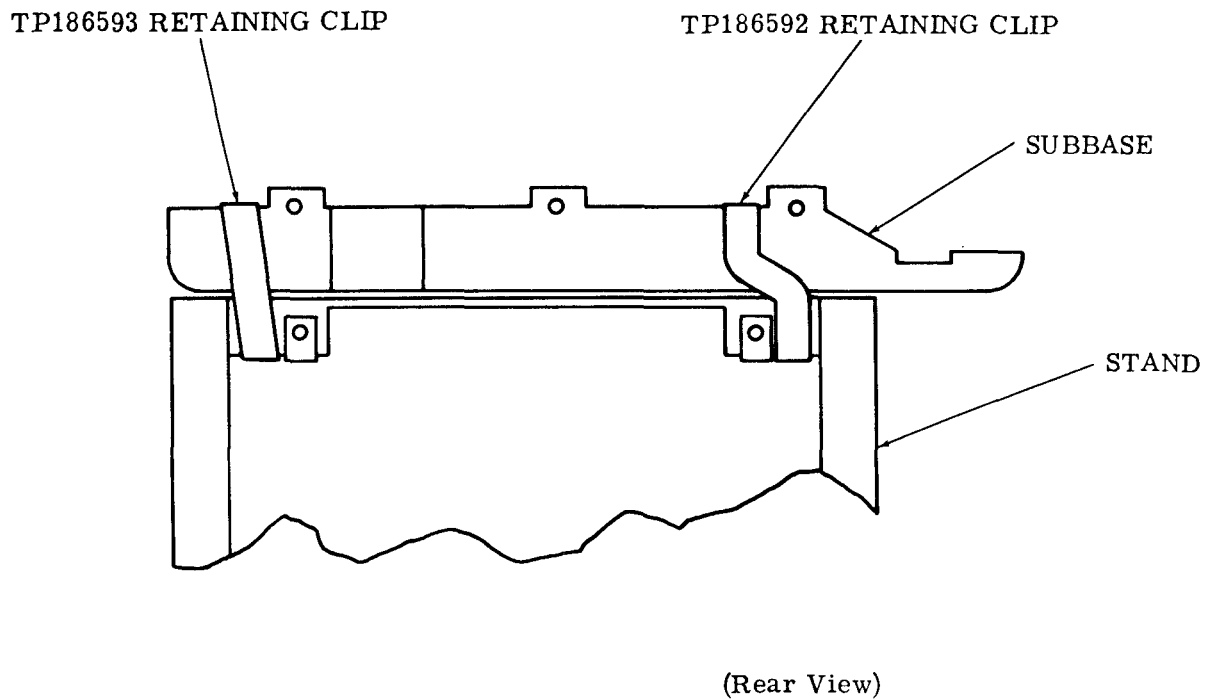

Figure 4 - Installation of Retaining Clips to Subbase and Stand

2.06 Code the answer-back drum in a counter-clockwise direction (Figures 5 and 6), starting with row no. 1.

Note: The ST row is the first row sensed at the beginning of an answer-back cycle. It is coded at the factory for character suppression and must not be recoded.

2.07 A particular character is coded by either retaining or removing tines within a row, as illustrated in Figure 5. A tine may be removed by either of the two following methods:

(a) Method 1: Place the end of a screwdriver blade at the base of a tine in the row previously coded. Press the side of the

blade against the top of the unwanted tine until the tine breaks off. Figure 5 illustrates this method — pressure applied to base of row no. 18 and against top of adjacent tine being removed from row no. 19.

(b) Method 2: Place the unwanted tine in the slot of a TP161686 tine tool, or grasp the tine firmly with long-nose pliers. With the tool or pliers held stationary, rotate the answer-back drum back and forth until the unwanted tine breaks off near its base. Do not damage adjacent tines.

Note: If a coding error is made, or for some other reason it is necessary to suppress (erase) characters from the answer-back drum, remove the character suppression tine from the row(s) affected.

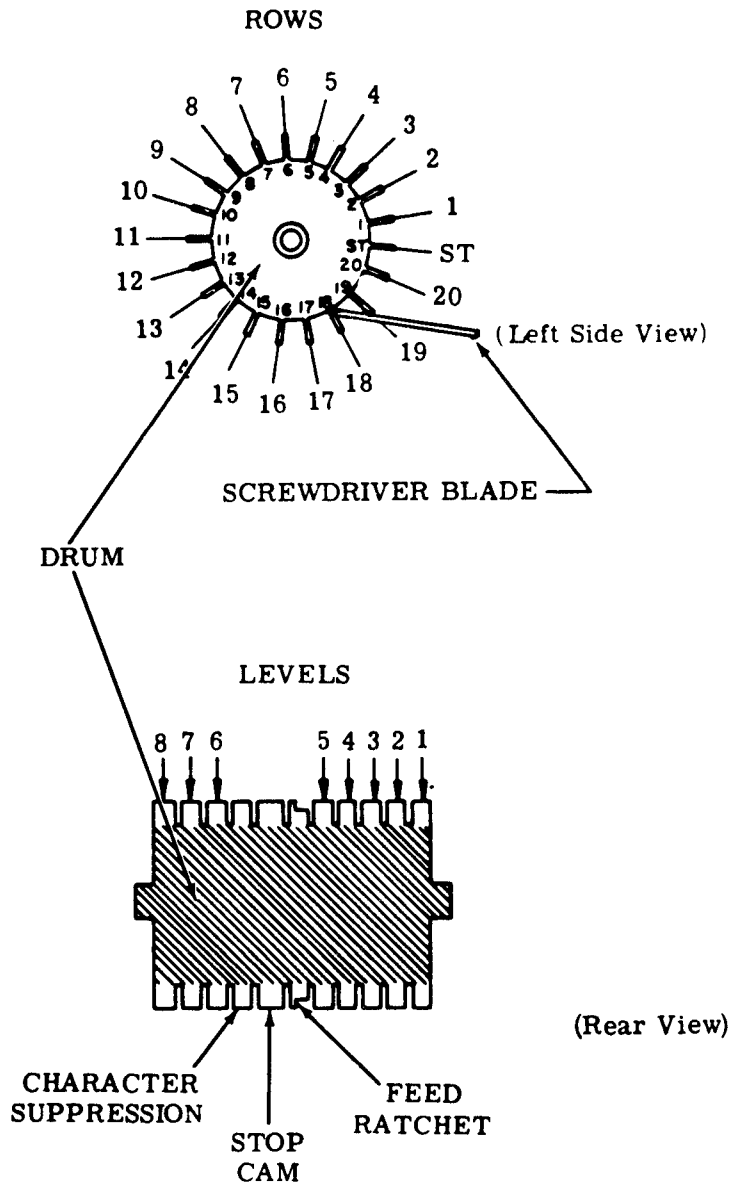

Figure 5 - Answer-Back Drum

CODE LEVELS								ASCII CODE			CODE LEVELS								ASCII CODE		
8	7	6	5	4	3	2	1	1967 Edition	1965 Edition	1963 Edition	8	7	6	5	4	3	2	1	1967 Edition	1965 Edition	1963 Edition
■	■	■	■	■	■	■	■	NUL		NULL	□	□	□	□	□	□	□	2			
□	□	□	□	□	□	□	□	SOH		SOM	□	□	□	□	□	□	□	3			
□	□	□	□	□	□	□	□	STX		EOA	□	□	□	□	□	□	□	4			
■	■	■	■	■	■	■	■	ETX		EOM	□	□	□	□	□	□	□	5			
□	□	□	□	□	□	□	□	EOT			□	□	□	□	□	□	□	6			
■	■	■	■	■	■	■	■	ENQ		WRU	□	□	□	□	□	□	□	7			
■	■	■	■	■	■	■	■	ACK		RU	□	□	□	□	□	□	□	8			
□	□	□	□	□	□	□	□	BEL		BELL	■	■	■	■	■	■	■	9			
□	□	□	□	□	□	□	□	BS		FE ₀	■	■	■	■	■	■	■	:			
■	■	■	■	■	■	■	■	HT		HT/SK	□	□	□	□	□	□	□	;			
■	■	■	■	■	■	■	■	LF			□	□	□	□	□	□	□	<			
□	□	□	□	□	□	□	□	VT		VTAB	□	□	□	□	□	□	□	=			
■	■	■	■	■	■	■	■	FF			□	□	□	□	□	□	□	>			
□	□	□	□	□	□	□	□	CR			□	□	□	□	□	□	□	?			
□	□	□	□	□	□	□	□	SO			□	□	□	□	□	□	□	@		@	
□	□	□	□	□	□	□	□	SI			■	■	■	■	■	■	■	A	\		
□	□	□	□	□	□	□	□	DLE		DC ₀	■	■	■	■	■	■	■	B			
□	□	□	□	□	□	□	□	DC1			□	□	□	□	□	□	□	C			
□	□	□	□	□	□	□	□	DC2			■	■	■	■	■	■	■	D			
□	□	□	□	□	□	□	□	DC3			□	□	□	□	□	□	□	E			
■	■	■	■	■	■	■	■	DC4		DC4 (STOP)	□	□	□	□	□	□	□	F			
□	□	□	□	□	□	□	□	NAK		ERR	□	□	□	□	□	□	□	G			
□	□	□	□	□	□	□	□	SYN		SYNC	□	□	□	□	□	□	□	H			
■	■	■	■	■	■	■	■	ETB		LEM	□	□	□	□	□	□	□	I			
■	■	■	■	■	■	■	■	CAN		S ₀	□	□	□	□	□	□	□	J			
□	□	□	□	□	□	□	□	EM		S ₁	□	□	□	□	□	□	□	K			
□	□	□	□	□	□	□	□	SUB	SS	S ₂	□	□	□	□	□	□	□	L			
■	■	■	■	■	■	■	■	ESC		S ₃	■	■	■	■	■	■	■	M			
■	■	■	■	■	■	■	■	FS		S ₄	■	■	■	■	■	■	■	N			
■	■	■	■	■	■	■	■	GS		S ₅	□	□	□	□	□	□	□	O			
■	■	■	■	■	■	■	■	RS		S ₆	■	■	■	■	■	■	■	P			
□	□	□	□	□	□	□	□	US		S ₇	□	□	□	□	□	□	□	Q			
□	□	□	□	□	□	□	□	SP		b	□	□	□	□	□	□	□	R			
■	■	■	■	■	■	■	■	!			■	■	■	■	■	■	■	S			
■	■	■	■	■	■	■	■	!"			□	□	□	□	□	□	□	T			
□	□	□	□	□	□	□	□	#			■	■	■	■	■	■	■	U			
■	■	■	■	■	■	■	■	\$			■	■	■	■	■	■	■	V			
■	■	■	■	■	■	■	■	%			□	□	□	□	□	□	□	W			
□	□	□	□	□	□	□	□	&			□	□	□	□	□	□	□	X			
□	□	□	□	□	□	□	□	'		'	■	■	■	■	■	■	■	Y			
□	□	□	□	□	□	□	□	(■	■	■	■	■	■	■	Z			
□	□	□	□	□	□	□	□)			□	□	□	□	□	□	□	[
□	□	□	□	□	□	□	□	*			■	■	■	■	■	■	■	\	~	\	
□	□	□	□	□	□	□	□	+			□	□	□	□	□	□	□]			
□	□	□	□	□	□	□	□	,			□	□	□	□	□	□	□	^			
□	□	□	□	□	□	□	□	-			■	■	■	■	■	■	■	_		↑	
■	■	■	■	■	■	■	■	.			□	□	□	□	□	□	□	~	→	ACK	
□	□	□	□	□	□	□	□	/			■	■	■	■	■	■	■	}		ALT.MODE	
□	□	□	□	□	□	□	□	0			■	■	■	■	■	■	■	~		ESC	
□	□	□	□	□	□	□	□	!			■	■	■	■	■	■	■	DEL			
□	□	□	□	□	□	□	□				■	■	■	■	■	■	■	{			

1 CYCLE OPER. ROW 6	■	■	■	■	■	■	■	■	■	■	■	■	■	■	■	■	■	■	■	■	■
1 CYCLE OPER. ROW ST	■	■	■	■	■	■	■	■	■	■	■	■	■	■	■	■	■	■	■	■	■
2 CYCLE OPER. ROWS 6 & 17	■	■	■	■	■	■	■	■	■	■	■	■	■	■	■	■	■	■	■	■	■
2 CYCLE OPER. ROWS ST & 11	■	■	■	■	■	■	■	■	■	■	■	■	■	■	■	■	■	■	■	■	■
3 CYCLE OPER. ROWS 6, 13, 20	■	■	■	■	■	■	■	■	■	■	■	■	■	■	■	■	■	■	■	■	■
3 CYCLE OPER. ROWS ST, 7, 14	■	■	■	■	■	■	■	■	■	■	■	■	■	■	■	■	■	■	■	■	■

CHARACTER SUPPRESSION ————
STOP CAM ————
FEED RATCHET ————

■ LEAVE TINE
□ REMOVE TINE

Note 1: Blank space indicates no change from latest edition.

Note 2: Codes shown are for even parity operation -- for nonparity, remove eighth level tine.

Figure 6 - Answer-Back Drum Coding

2.08 The length of an answer-back sequence can be varied either by removing the stop cam tine(s) and/or the character suppression tine(s).

(a) For short sequences, code the drum for either 2- or 3-cycle operation by removing the appropriate tine(s) as indicated in Figure 6.

(b) Removal of the character suppression tine from any row prevents transmission from the answer-back mechanism. To shorten the answer-back sequence, remove the suppression tine from any unused row(s) after the end of a message.

Note: Do not remove the character suppression tine from the last row of each segment of the answer-back drum — row no. 20 for answer-back drums coded for 1-cycle operation — on sets used in systems where a response to each answer-back activation signal must be obtained. The last row can be coded with any other character that is compatible with the particular system.

2.09 The number of rows available for message coding is shown below for 1-, 2-, or 3-cycle operation.

CYCLE OPERATION	TOTAL ROWS	AVAILABLE ROWS
1	21	20
2	10 (11)*	9 (10)*
3	7	6

*Alternately one, then the other.

2.10 The number of rows available for actual station identification is less than shown above, because each coded message should begin and end with CARRIAGE RETURN and LINE FEED (this may be altered in specific applications). This assures that the transmitted message will appear at the beginning of a line of the receiving teletypewriter set and eliminates overprinting.

2.11 In switched network service, the station identification for 1-cycle operation may not exceed 14 characters, including spaces. The answer-back drum should be coded as follows.

ABBREVIATION

KEY TO ABBREVIATION

ACK	Acknowledge
CR	Carriage Return
LF	Line Feed
RO	Rub Out
SP	Space
SUP	Character Suppression

(a) Example 1:

SUP CR LF RO
 TELETYPE SP NILES CR LF ACK
 Company City

Station Identification
 (Maximum-14 characters)

Note: In this system, the ACK character code combination must be the final significant character code combination in the coded answer-back message.

(b) Example 2:

SUP CR LF RO
 ERIE SP BOST CR LF ACK SUP
 SUP SUP SUP SUP
 Company City

Station Identification
 (Less than maximum number of characters)

Note: If the station identification is less than the maximum of 14 characters in length, then the remaining rows on the answer-back drum must be coded with the character suppression code according to Example 2 above.

2.12 To replace the answer-back drum, place the TP180854 brace in its detented open position, and lift feed pawl (do not overextend its spring). Replace drum with its shaft firmly seated in the contact block slots. Release feed pawl and TP180854 brace. Rotate answer-back drum to assure proper seating of its associated parts. Check that the contact wires are located in their proper slots.

ELECTRICAL CONNECTIONS AND PRE-SERVICE PROCEDURES

CAUTION: MAKE SURE POWER CORD IS NOT CONNECTED.

33 Sets

2.13 Refer to the appropriate wiring diagrams packed with the teletypewriter set.

2.14 Connect the signal line leads (supplied by customer) to the terminals on the terminal board at the rear of the call control unit as indicated in the wiring diagram.

2.15 Connect power cord to an ac source, 115 volt 60 Hz.

2.16 Check DASHPOT ORIFICE (Spacing Area) adjustment, since altitude may have some effect on dashpot operation. See Section 574-122-700TC.

2.17 Sets equipped with an answer-back mechanism must be tested for proper response to a predetermined call character such as WRU. The following procedure is recommended for performing this test.

(a) Use a predetermined call character such as WRU, to call in the newly installed set.

(b) The set should establish the connection and automatically transmit the answer-back message.

Note: Set will not respond if the suppression time has been removed from the last row. See 2.07 (b).

(c) If proper response is not obtained, check and correct the answer-back area adjustments (Section 574-122-700TC), beginning with those of the following list.

DRUM POSITION
TRIP LEVER CLEARANCE
FEED PAWL POSITION
FEED LEVER POSITION
"HERE-IS" BELLCRANK POSITIONING
TRIP BAIL POSITIONING
CHARACTER SUPPRESSION CONTACT
WIRE GAP

3300 Series Coded Sets

2.18 The 3300 Series Coded Sets are shipped from the factory with the automatic carriage return-line feed feature in the typing unit disabled by means of clips. The clips mount over slots in the TP180950 front tie bar. To enable this feature on friction feed sets remove

the clip over slot A. To enable this feature on sprocket feed sets remove the two clips, in slot A and slot L.

Note: Slot A is not stamped on the function casting. Refer to 574-122-700TC for orientation.

2.19 Connect the signal line leads (supplied by customer) to the terminals on the terminal board at the rear of the call control unit as indicated in the wiring diagram.

2.20 The 3300 Series Coded Sets are shipped from the factory with the even parity option installed in the keyboard. The customer may:

(a) Retain even parity, or

(b) Wire the keyboard for the 8th bit always marking, or

(c) Wire the keyboard for the 8th bit always spacing.

The wiring options are installed by connecting wires to terminals at the right front of the keyboard and at the left contact block (see Figure 7). The options are shown in the Keyboard Wiring Options Table.

2.21 Check the DASHPOT ORIFICE (Spacing Area) adjustment, since altitude may have some effect on dashpot operation. See Section 574-122-700TC.

2.22 Test the answer-back operation as described in 2.17.

Computer Input/Output Sets

2.23 Check DASHPOT ORIFICE (Spacing Area) adjustment, since altitude may have some effect on dashpot operation. See Section 574-122-700TC.

2.24 Low Tape Contact Adjustments:

(a) Operating Arm Adjustment (Figure 8): Replace cover. With tape spindle in place, there should be 5/16 inch to 7/16 inch clearance between operating arm and tape spindle. To adjust, bend operating arm.

(b) Operating Arm Clearance (Figure 9): Remove cover. The operating arm should have a minimum of 1/8 inch clearance

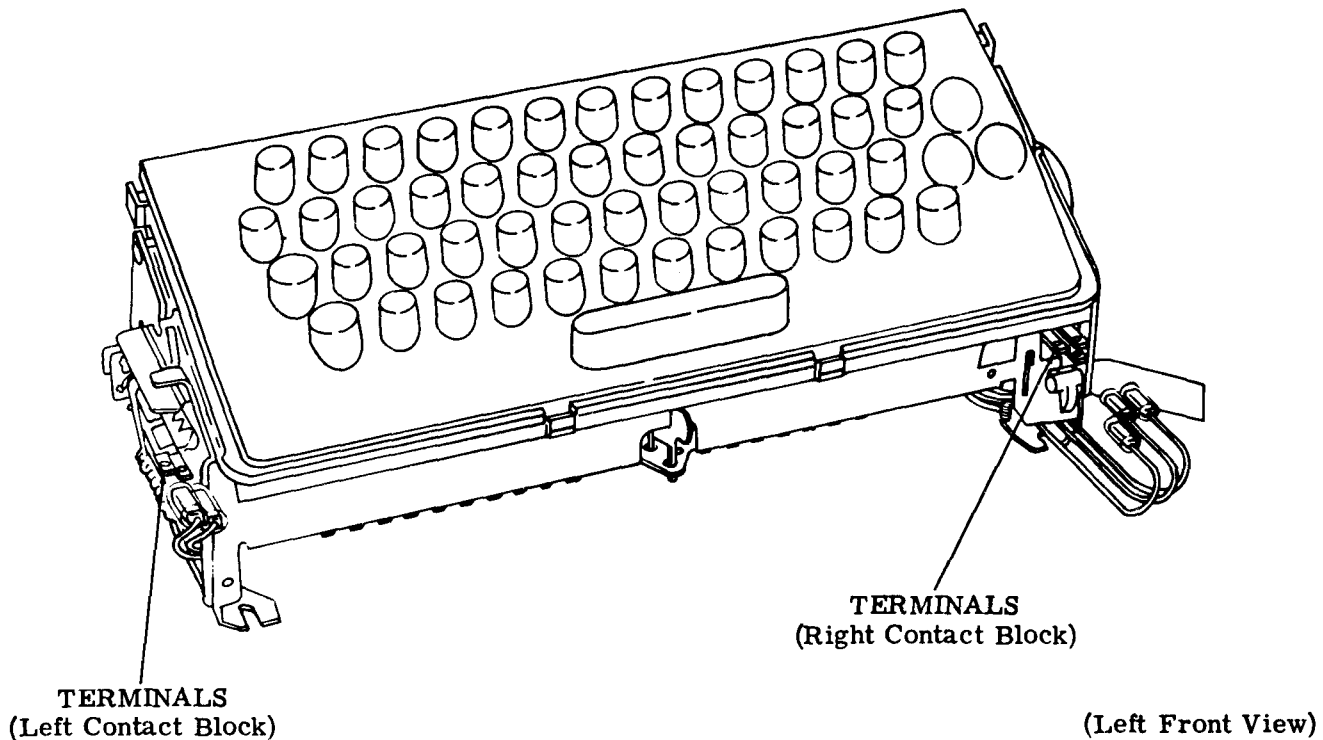

Note: Push the terminals on the contacts with long nose pliers. It should be possible to install the parity options without removing the keyboard.

Figure 7 - Location of Terminals on Keyboard
for Parity Options

KEYBOARD WIRING OPTIONS TABLE

OPTION	LEAD 1 Left Contact Block Color: Red-Green	LEAD 2 Left Contact Block Color: Green	LEAD 3 Right Contact Block Color: Green	LEAD 4 Right Contact Block Color: White-Slate
Even parity	ON	OFF	OFF	ON
8th bit Always mark	OFF	ON	ON	ON
8th bit Always space	Either Lead 1 or Lead 2 ON or both OFF		ON or OFF	OFF

Note 1: Tape and store unused leads.

Note 2: Reference: 9334WD

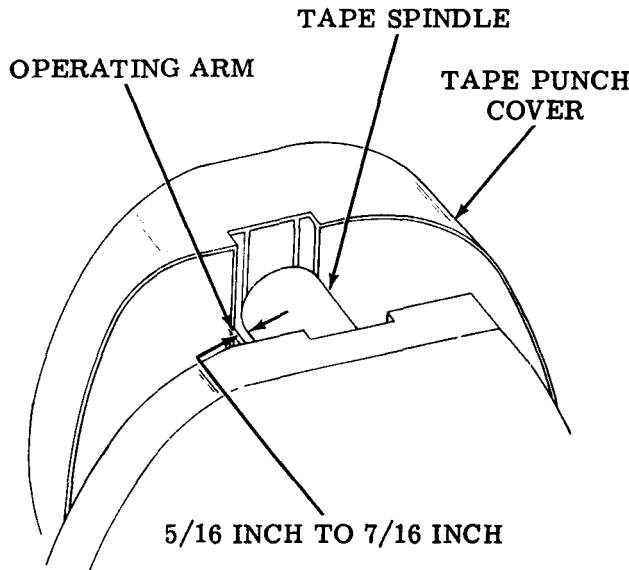

(Left Rear View)

Figure 8 - Operating Arm Adjustment

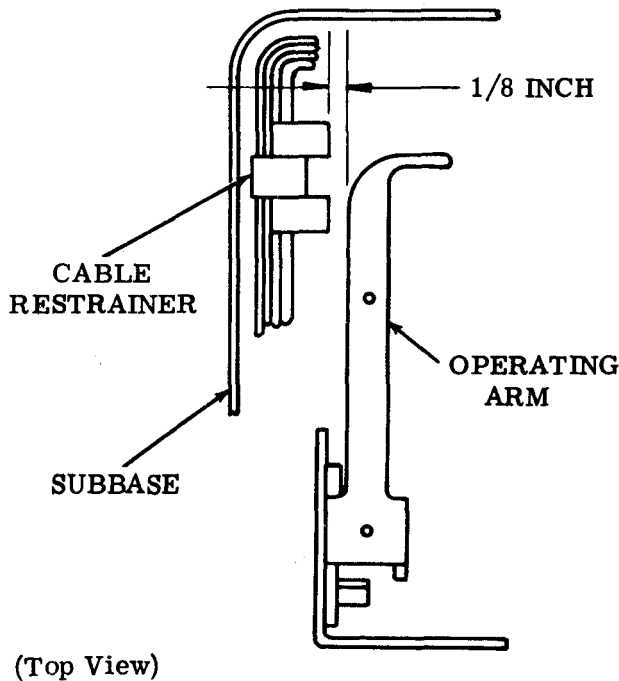

(Top View)

Figure 9 - Operating Arm Clearance

between the left edge of the operating arm at the closest point and the cables and cable restrainer at the left rear corner of the set. Gauge by eye. To adjust, bend switch bracket and/or reposition cables and reform cable restrainer.

(c) Operating Arm Clearance (Figure 10): Install cover. The tape roll should not touch the operating arm at any point other than the activating portion of the arm. To adjust, bend switch bracket and/or reposition cables and reform cable restrainer.

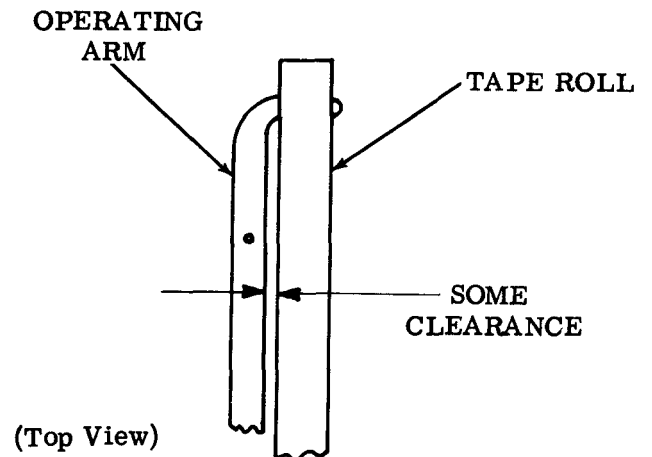

(Top View)

Figure 10 - Operating Arm Clearance

2.25 Air Deflector (Motor Area) Adjustment:

Note: This adjustment applies to 50 Hz I/O sets only.

(a) There should be at least 1/8 inch clearance at closest point between air deflector and motor fan. To adjust, position and/or bend air deflector.

(b) There should be some clearance between air deflector and the low paper alarm sensing rod so that the air deflector does not interfere or restrict the total travel of the sensing rod. To adjust, position and/or bend air deflector.

2.26 Test the answer-back operation as described in 2.17.

- 2.27 Connect power cord to ac source, 115 volt, 60 Hz or 50 Hz.

PLACEMENT

A. Without Stand

- 2.28 If a stand is not included, place the teletypewriter set on the surface where it is to be used.

B. With Stand

- 2.29 Figure 3 illustrates the facilities for leveling and anchoring the stand.

- 2.30 Place the partially assembled set where it is to be used. If the set rocks to one side or another, tip it slightly and reposition the leveling screws.

Note: Reaction to the carriage returning to its left position may cause early design teletypewriter sets to move across the floor toward the left. To correct this, either add weight to the stand, arrange to have it bolted to the floor, or drill one 0.328 inch diameter hole into each leg and install TP182285 rubber bumper in each leg.

- 2.31 If the teletypewriter set is to be bolted to the floor, place stand at the desired location and drive lag bolts into the floor through the front holes in the legs.

- 2.32 Place the relay rack inside the stand.

3. FINAL ASSEMBLY

GENERAL

- 3.01 Replace the back panel onto the stand, if used, using the removed screws.

Note: Before replacing an ASR cover, remove the retaining clip (early design units only) from the tape reader upstop screw (Figure 15). Also, prepare the punch on 3300 Series Coded Sets for manual or automatic operation as described in 6.01.

- 3.02 Replace the cover over the typing unit and onto the subbase (Figure 2). Take care that all seams are tight and that keyboard push-buttons, dial, etc, are properly aligned. Insert and tighten the cover mounting screws removed during PREPARATION FOR INSTALLATION.

Note: On an ASR Set, insert and tighten screw at left rear corner of tape reader cover.

- 3.03 Replace the nameplate making sure that the formed lip fits around the bottom of the flange on the cover, that the top edge is behind the small lip on the cover, and that the bottom of the nameplate rests on top of the two small projections on the subbase.

- 3.04 Replace the volume control knob or the power switch rotary knob, if either is used, by positioning and pushing it rearward.

- 3.05 Position the bezel, if used, on the cover over the call control unit. Insert and tighten its two mounting screws.

- 3.06 On friction feed typing units, align the platen knob with the flat on the left side of the platen. Push knob in place. On sprocket feed typing units, install platen knob on left side of platen. Fully seat knob to the right and secure it with the screw provided.

RIBBON INSTALLATION

- 3.07 Figure 11 illustrates ribbon threading.

- 3.08 Raise the cover lid. Pull both spools off the friction spindles.

- 3.09 Engage the hook at the end of the ribbon in the hub of the empty spool; if there is no hook, pierce the end of the ribbon over the point of the arrow in the hub of the empty spool. Wind a few turns of ribbon onto the empty spool in the direction indicated by the arrow, and make sure that the reversing eyelet has been wound upon the spool.

- 3.10 Place the spools on the shafts in such a manner that the ribbon feeds to the rear from the right side of the right spool and from the left side of the left spool. Turn each spool slightly until the spool driving pin engages the hole in the spool. Guide the ribbon around the right vertical post and through the slot in the reverse arm. Place the ribbon in the ribbon guide behind the typewheel. Guide the ribbon through the left side of the reverse arm and around the vertical post. Rotate the spool to take up any slack.

PAPER OR FORM INSTALLATION

A. Friction Feed

- 3.11 A friction feed teletypewriter set accommodates a standard roll of paper 8-1/2 inches wide and 5 inches in diameter. Figure 12 illustrates paper threading for a friction feed typing unit.

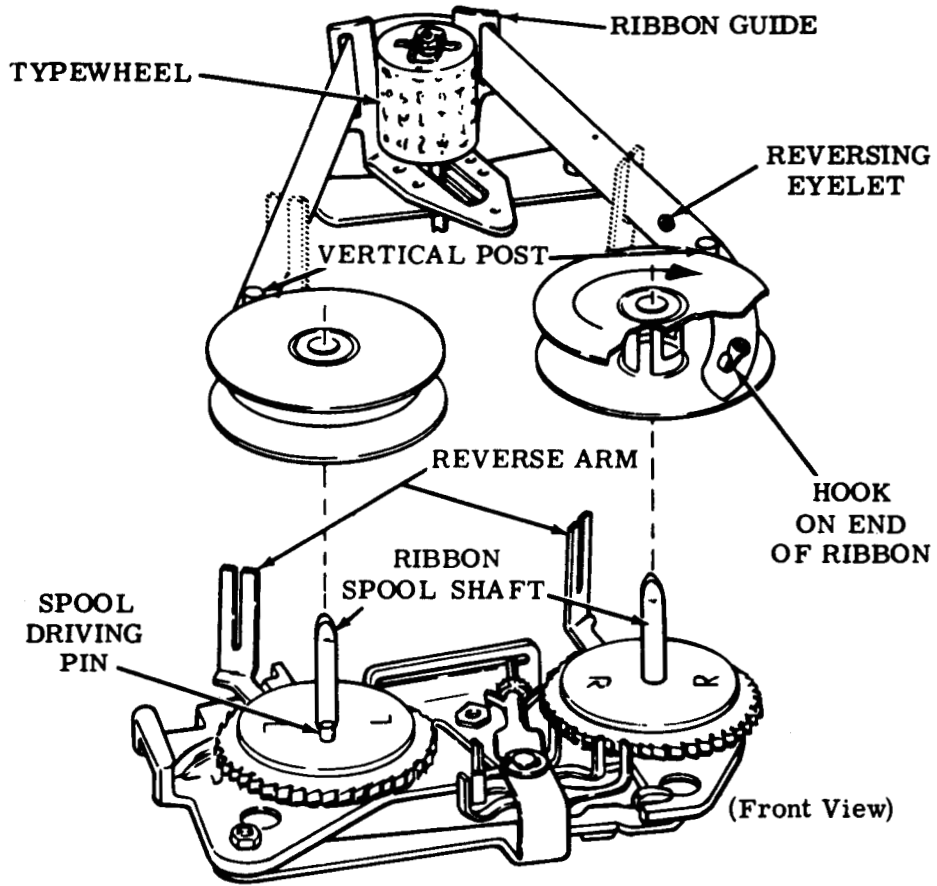

Figure 11 - Ribbon Threading

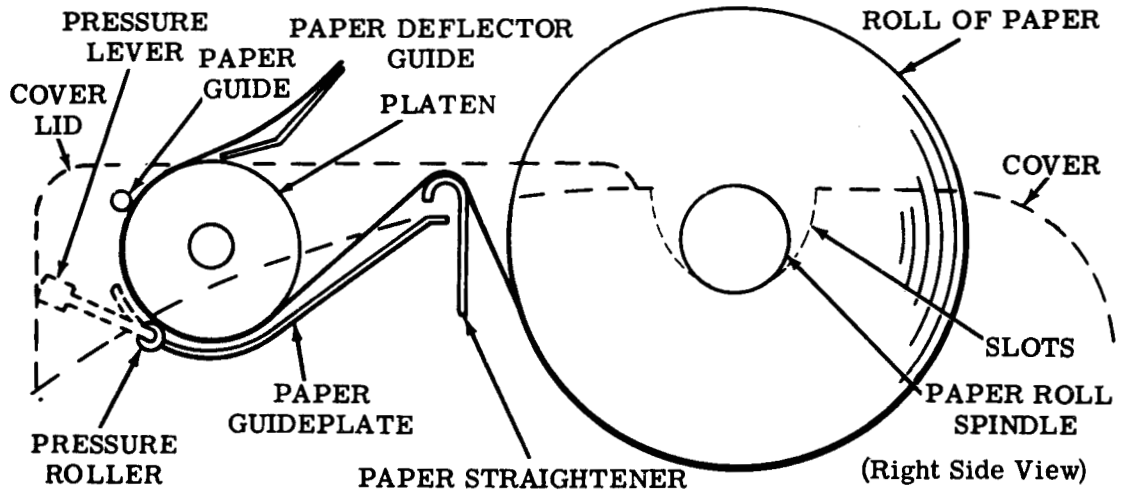

Figure 12 - Paper Threading — Friction Feed

3.12 Insert the paper roll spindle into the roll of paper so that an equal length of spindle is exposed at either end of the roll. Place roll into the cover recess with the ends of the spindle resting in the slots so that the paper will unroll from the bottom.

3.13 Raise the cover lid. Release pressure roller tension by moving the pressure lever forward. Prepare a smooth leading edge of paper. Pass paper over paper straightener, under platen, and under paper guide. Straighten paper and reapply the pressure roller tension. Close the cover lid.

Note: When typing units are stored or out of service for an extended period of time, release the pressure roller tension.

B. Sprocket Feed

3.14 A sprocket feed teletypewriter set accommodates forms 8-1/2 inches wide and of various lengths. The forms are normally passed to the typing unit from a conveniently located supply at the rear of the set.

3.15 Place the paper roll spindle into the paper recess of the cover so that it rests in the slots provided.

3.16 Figure 13 illustrates form threading for a sprocket feed typing unit.

3.17 **Form Threading:** Raise the cover lid. Pass the leading edge of the first form under the paper roll spindle. Thread the form under the low-paper and paper-out arms, if used, and between the platen and paper guideplate. Guide the form squarely into the platen and rotate the platen until the form is advanced by the sprocket pins. Lift up the wire guide and continue to rotate the platen until the form is under the wire guide and positioned for the first typing line. Lower wire guide and cover lid. After the first form is fed out, lift the form over the paper roll spindle to separate the incoming forms from the outgoing forms.

3.18 Figure 14 illustrates the zeroizing position of the platen drive mechanism for one cam lobe operation. For platen drive mechanisms using more than one cam lobe, see the CAM ZERO POSITION (Platen Drive Area, Sprocket Feed Mechanism) adjustment in Section 574-122-700TC.

3.19 **Zeroized Position:** Position a form at its first printing line in the typing unit. Depress the zeroizing button and rotate the pulley until the index plate is lined up with the pointer. Release the zeroizing button.

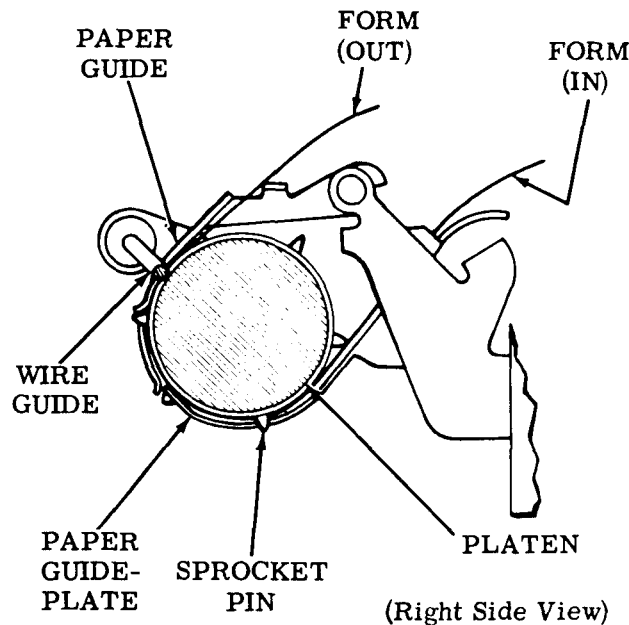

Figure 13 - Form Threading — Sprocket Feed

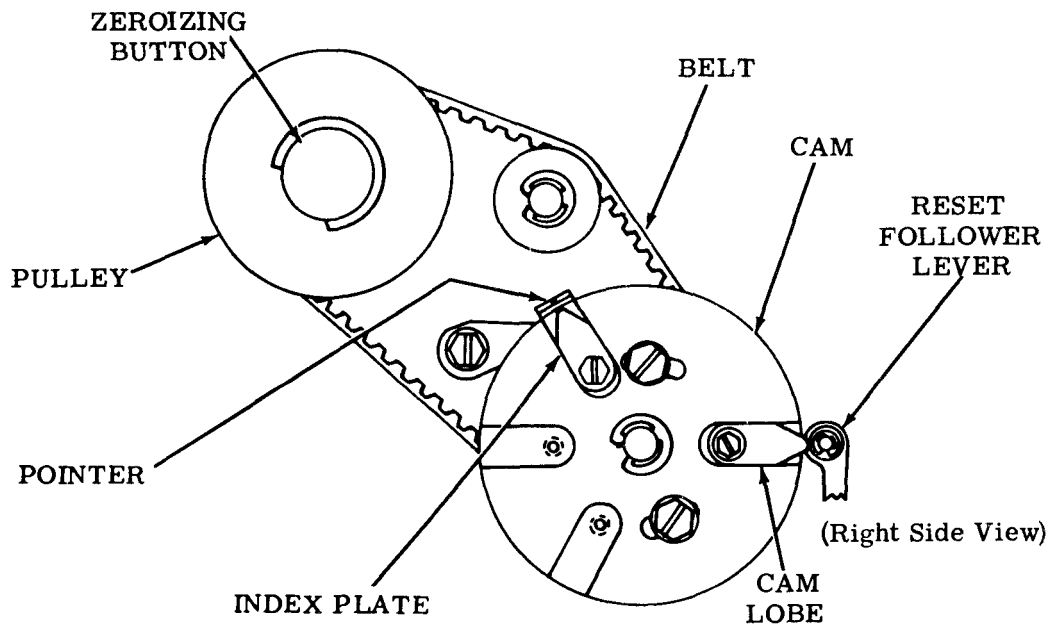

Figure 14 - Zeroizing Position of Platen Drive Mechanism — One Cam Lobe Operation

Note 1: To initiate the action to feed out a form, depress the CTRL and FORM keytops. The form-out mechanism will not respond to successive commands to feed out a form. At the end of a form feed-out, advance the form at least one line before issuing a second form-out command.

Note 2: The typing unit, in an ASR Set, operates one cycle behind the tape reader. Thus, a nonprint fill in code selection is required immediately after each form-out selection for proper set operation.

4. TAPE READER

4.01 A retaining ring or clip (Figure 15) is assembled (on early design units) to the upstop screw to prevent the sensing pins from being dislodged during shipment. This retaining clip must be removed before placing the tape reader in operation.

4.02 When inserting tape into the tape reader prior to operation, allow enough slack in the tape between the tape punch and the reader so that the reader lid can be easily closed.

CAUTION: THE TAPE READER OPERATES UNDER HIGH VOLTAGE. PRECAUTIONARY MEASURES SHOULD BE TAKEN WHENEVER POWER TO THE TAPE READER IS TURNED ON. HIGH VOLTAGE FROM THE POWER PACK WILL CONTINUE UNTIL APPROXIMATELY 10 SECONDS AFTER THE TAPE READER HAS BEEN DISCONNECTED.

4.03 Do not place the control lever beyond the STOP position while the tape reader is operating under power. The reader must come to a complete stop before placing the control lever in the FREE position.

5. POWER PACK ASSEMBLY

5.01 The 3300 Series Coded Sets and Computer I/O Sets have the power pack for the tape reader mounted in the call control unit. Therefore no installation is required. For 33 sets, the reader power pack mounts inside the stand, underneath the base. Two clips attach the power pack to the stand at the left front corner when the set is viewed from the rear. See Figure 16.

5.02 The auxiliary ASR power supply is mounted in the enclosure of the stand. It is used in the off-line mode to provide 115 volts

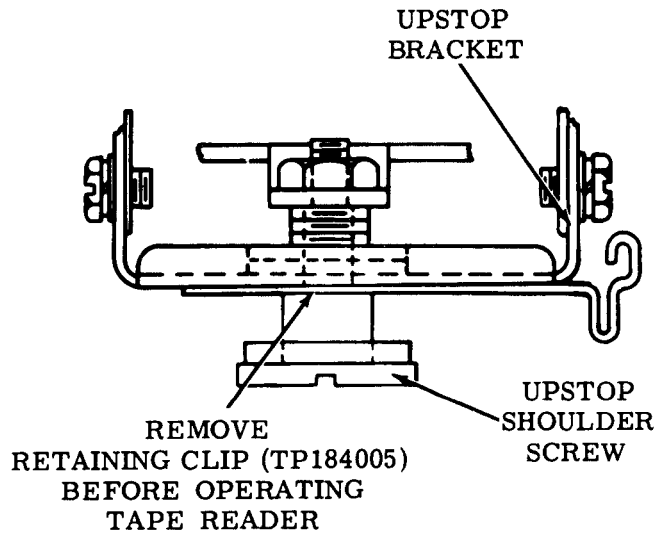

Figure 15 - Tape Reader Upstop Bracket Retaining Clip

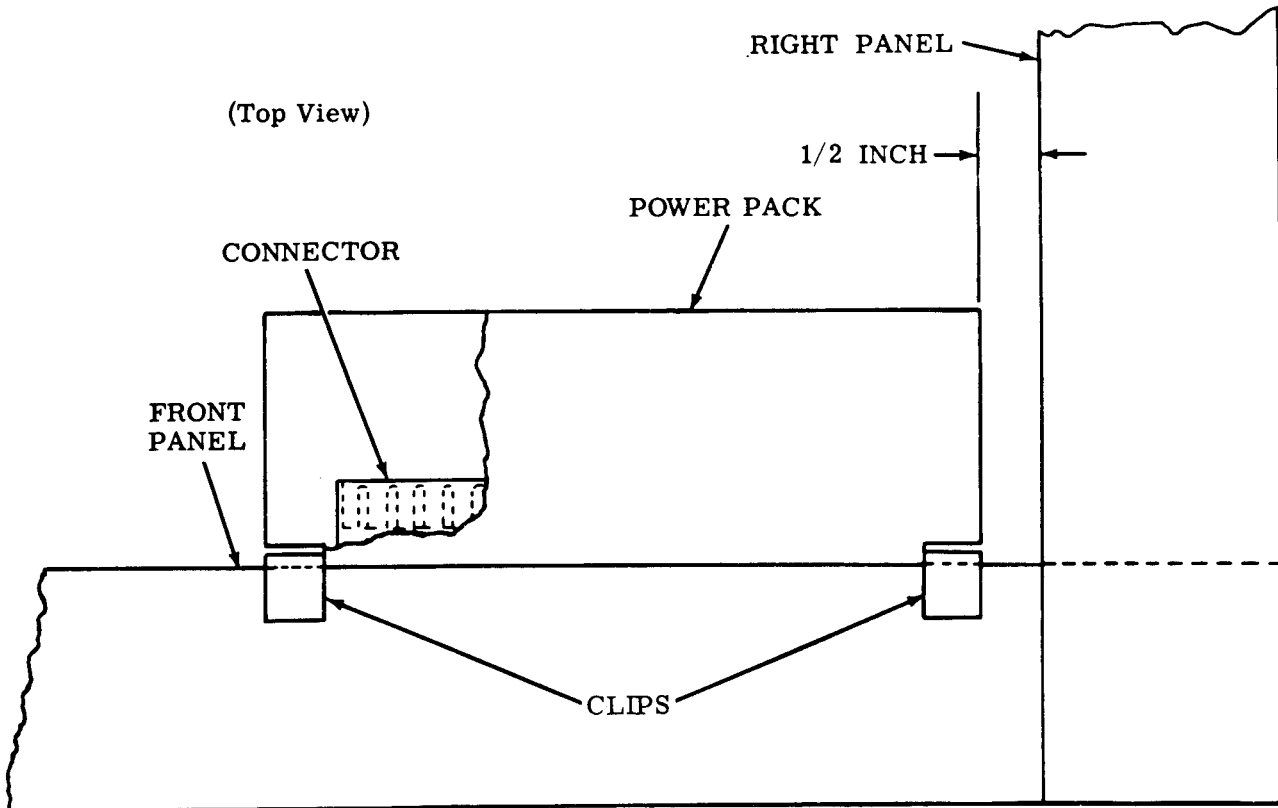

Figure 16 - Power Pack Assembly

on the tape reader, answer-back, and distributor contacts when a tape reader is used. When the tape reader is not used, a plug with a jumper wire is inserted in position R2 at the rear of the call control unit.

6. TAPE PUNCH

6.01 The 3300 Series Coded Sets are shipped with the tape punch having two disabling clips installed in slots A-O and A-8. If manual operation of the tape punch is desired, retain the two clips; if automatic operation is desired, remove the two clips. See Figure 17. The 33

I/O sets do not have clips, but have either a manual or an automatic tape punch.

6.02 Figure 18 illustrates the installation of a tape spool in a tape roll.

- (a) For 2-inch inside diameter tape rolls, use the tube-type spool.
- (b) For 1-inch inside diameter tape rolls, use the 2-piece spool.
- (c) Place the tape and spool into the tape punch cover so that the leading edge of the tape is at the top of the roll.

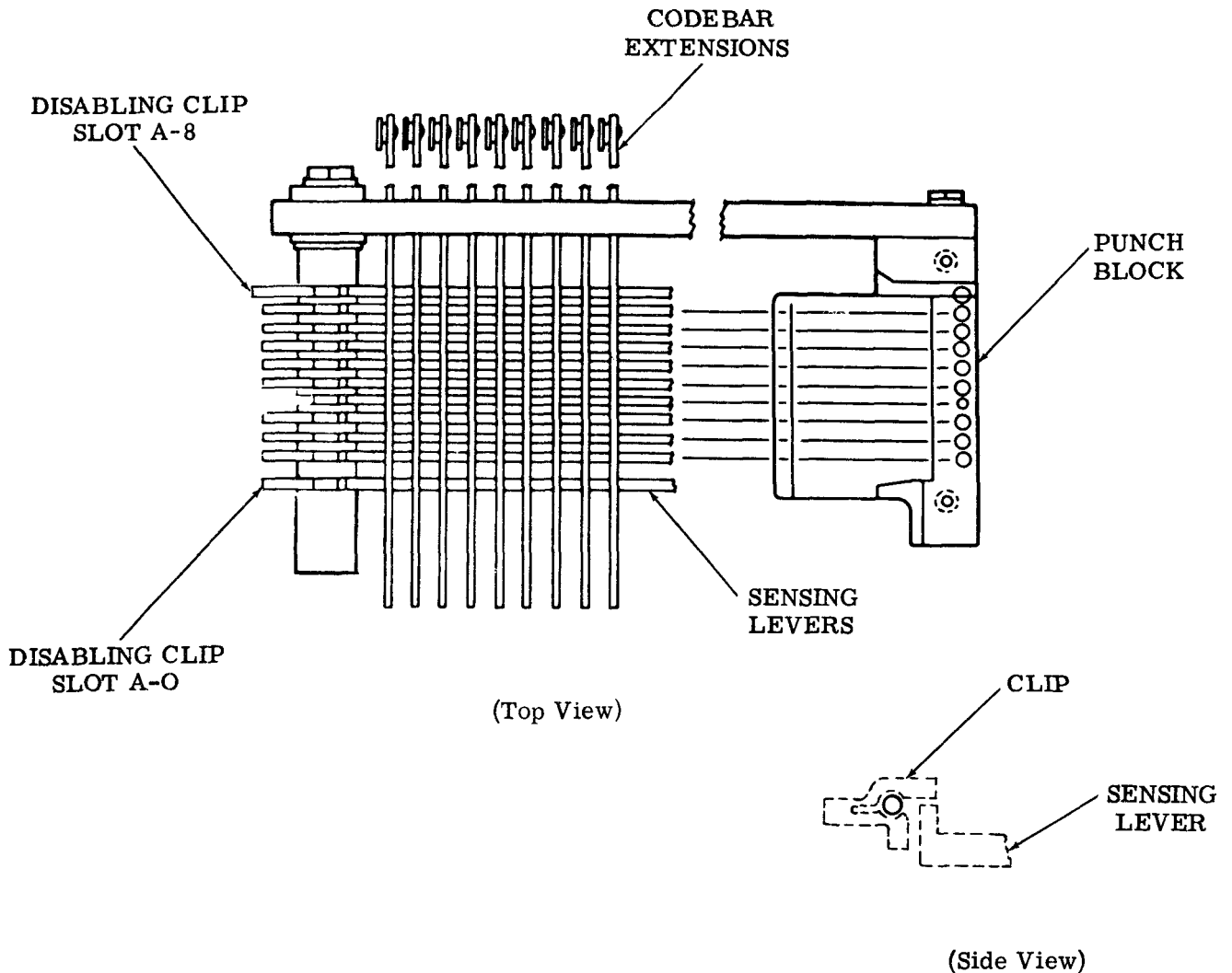

Figure 17 - Tape Punch Disabling Clips

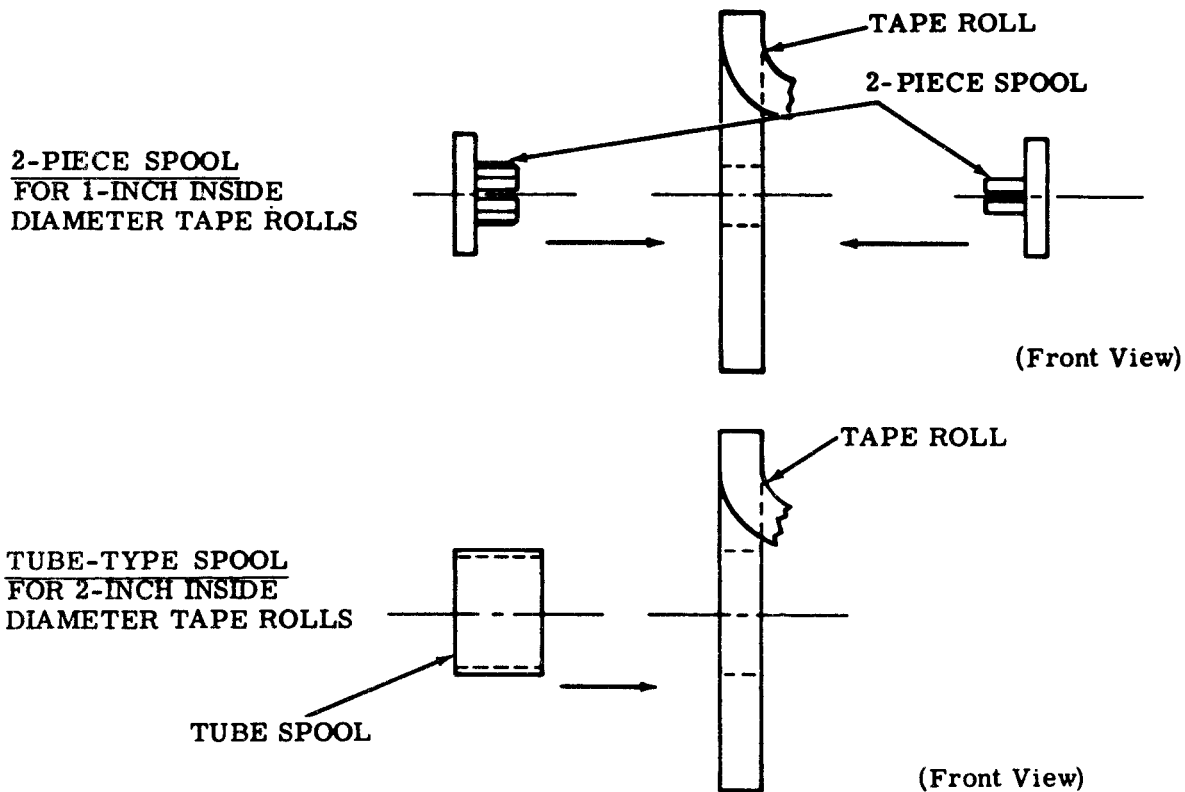

Figure 18 - Tape Roll and Tape Spool Assembly

6.03 Figure 19 illustrates the chad box installation.

- (a) Assemble the chad box under the tape punch pan by inserting the back of the flanged surface between the stand and the typing unit subbase.
- (b) Push the chad box toward the rear until the bent surface located at the front of the chad box engages the stand. An embossing located on the front bottom surface of the flanged surface engages an oblong hole in the stand and holds the chad box in place.
- (c) To empty the chad box, lift the front slightly and pull the chad box toward the front until it becomes disengaged.

7. RESHIPMENT

7.01 If the teletypewriter set is to be shipped to another location without its cover, the following must be done to avoid damage to the typing unit.

- (a) Remove subbase and typing unit from the stand.
- (b) Remove the plug button from the forward mounting hole in the bottom of the subbase.
- (c) Secure typing unit to the base by inserting and tightening the screw and washer previously stored in the TP181104 cable clip (1.09). Do not damage the typing unit by overtightening the screw.
- (d) Store the removed plug button in the TP181104 cable clip.

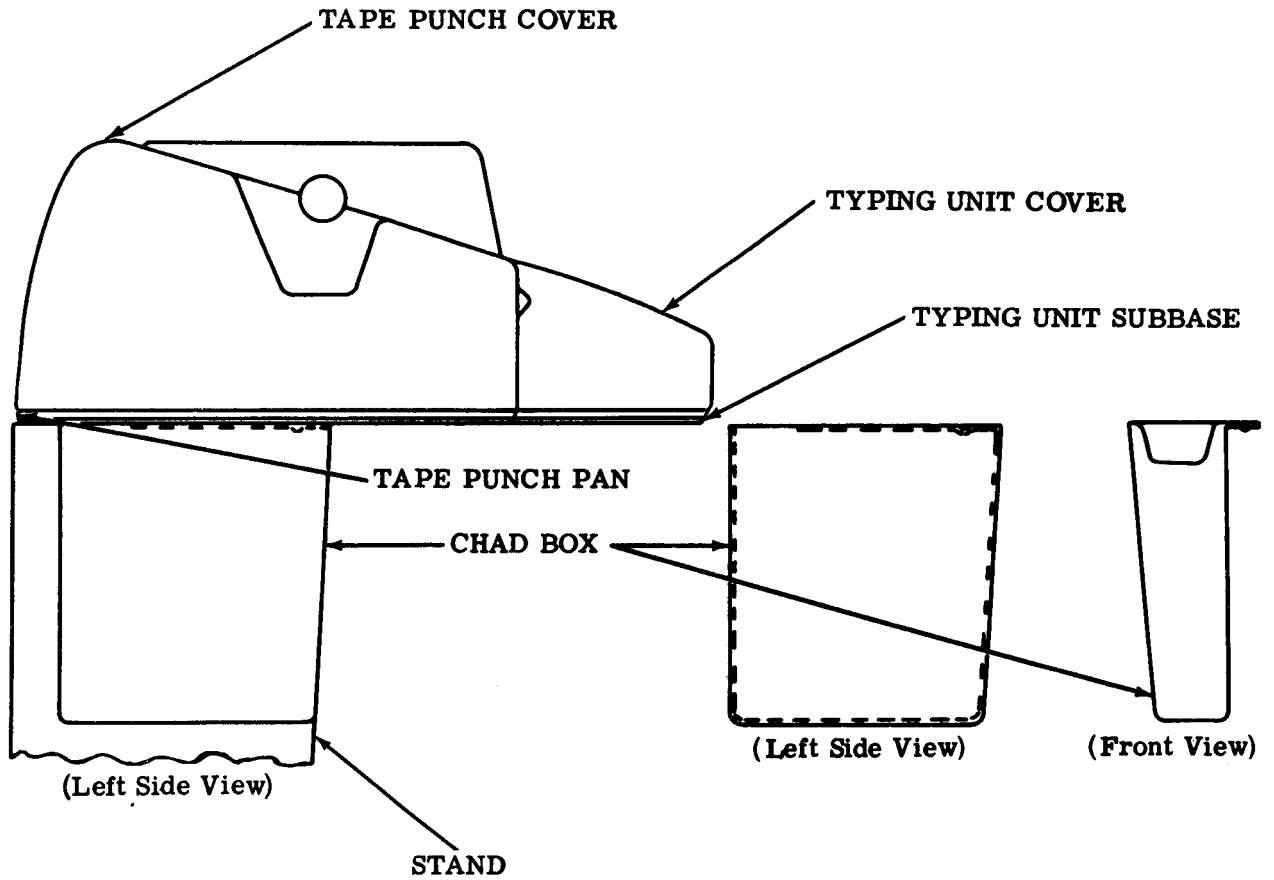

Figure 19 - Tape Punch Chad Chute Assembly

8. OPTIONAL FEATURES

A. Copyholder

8.01 With the line guide facing forward (Figure 20), insert the rear mounting tabs in the lower mounting slots. Pivot the copyholder to align the front mounting tabs above their mounting slots. Push copyholder downward until the tabs are fully seated.

B. Busy Circuit

8.02 The teletypewriter set is normally wired in a "don't answer" mode of operation for low-paper alarms and out-of-service. In this

mode, the set will not answer an incoming call. To wire the teletypewriter set to indicate "busy" instead of not answering, move the black-slate wire from terminal no. 2 to terminal no. 4 on the ringer terminal strip.

C. Hand Receiver

8.03 To install the hand receiver, connect the two white wires to terminals no. 5 and no. 6 on the 9-point terminal board.

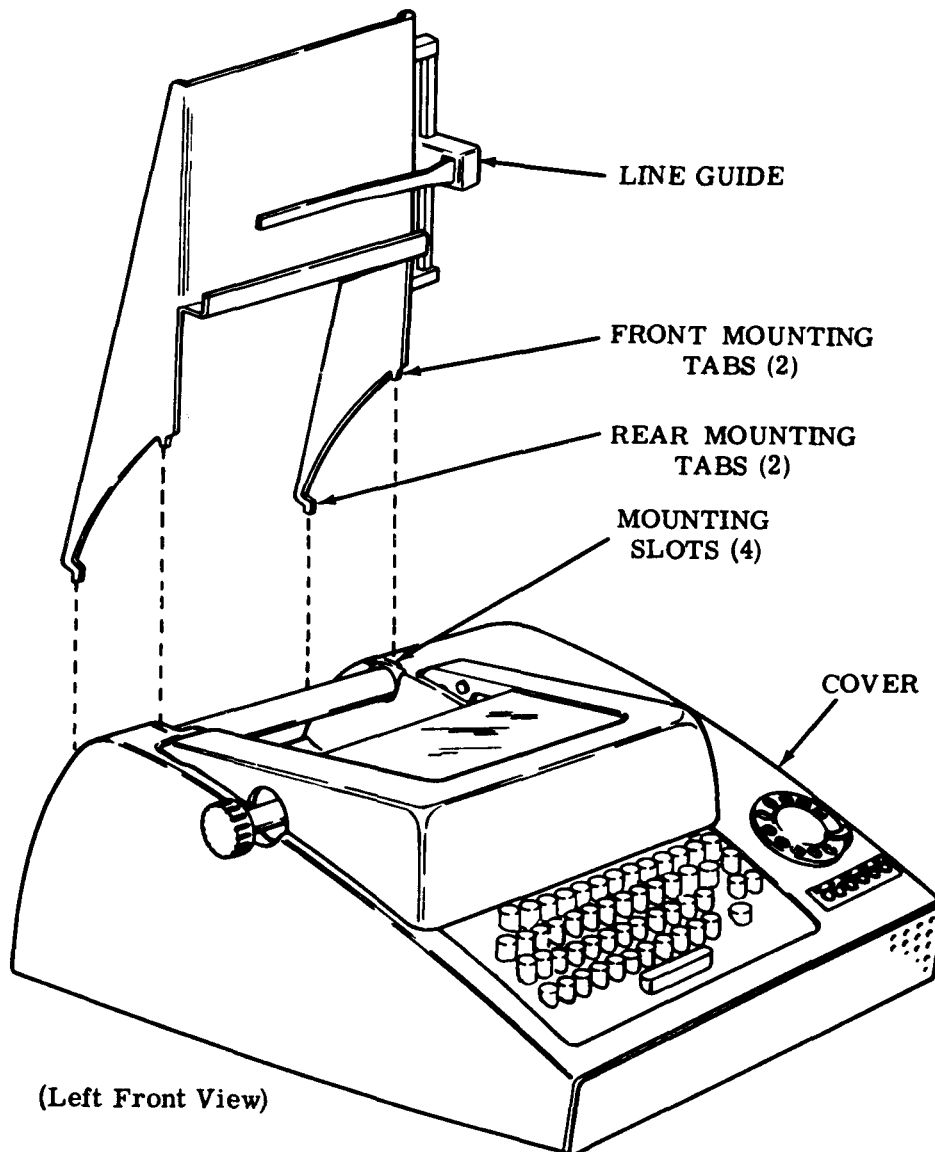

Figure 20 - Copyholder

33 TELETYPEWRITER SET

REMOVAL AND REPLACEMENT OF COMPONENTS

CONTENTS	PAGE
1. GENERAL	1
2. REMOVAL AND REPLACEMENT	1
COVER	1
TYPING UNIT	2
KEYBOARD	4
CALL CONTROL UNIT	5
TAPE READER	5
PUNCH	6

1. GENERAL

1.01 This section provides removal and replacement of components for the 33 teletypewriter set. It is reissued to include information for Computer Input/Output Sets, 3300 Series Coded Sets, and to make minor corrections. Marginal arrows indicate the changes and additions.

1.02 References to left, right, front, rear, etc, consider the set as viewed from the normal operating position.

1.03 The removal procedure given in this section subdivides the set into its major components. Each removal procedure is written assuming the set to be completely assembled, that is, no components previously removed. If further disassembly of the component is required, refer to the appropriate disassembly and reassembly section or the illustrated parts section which gives detailed arrangements of all parts. Where it will help in determining their location, the numbers of the parts are given in the instructions.

1.04 All tools used to remove the major components referred to in this section can be found in the 570-005-800TC standard tool section.

1.05 All damaged, worn, or distorted parts should be replaced if encountered in the removal and replacement procedure.

CAUTION: BEFORE REMOVING COMPONENTS, REMOVE CONNECTORS FROM EXTERNAL RECEPTACLES (POWER SOURCE, DATA SET, ETC).

2. REMOVAL AND REPLACEMENT

COVER

2.01 To remove the set cover (Figure 1), proceed as follows.

- (a) Remove paper and paper roll spindle. Remove bezel, if used, on call control unit by removing screws. Remove the volume control knob, if used, or the power switch rotary knob, if used, by pulling forward. Remove the nameplate by pulling it down and out. Remove the platen knob used on friction feed typing units by pulling it to the left. On sprocket feed typing units, remove a platen knob screw first, then remove the platen knob by pulling it to the left.

- (b) Remove the four TP181141 screws from front and the three TP184085 screws from rear of typing unit cover.

Note: On Automatic Send-Receive (ASR) Teletypewriter Sets, remove the TP183112 screw from left rear corner of the tape reader cover.

- (c) Gently lift the cover from the subbase and set it aside.

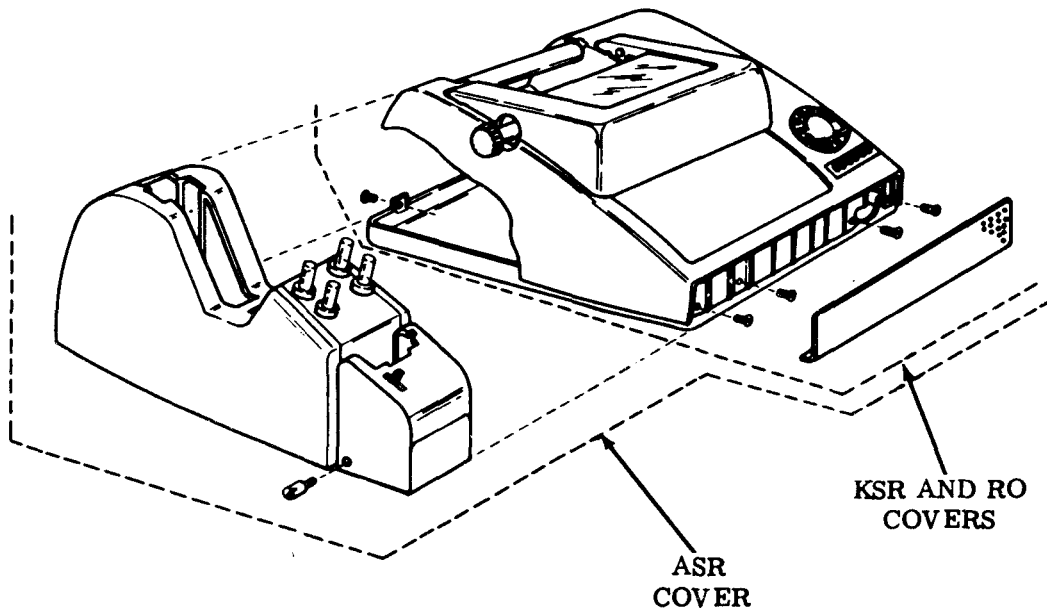

Figure 1 - Set Covers

Note: On Automatic Send-Receive (ASR) Teletypewriter Sets, the typing unit cover, tape punch cover, and reader cover are all interconnected and they remove as one unit. If desired the three covers can then be separated from each other.

(d) To replace the cover on sets with low paper alarm switch, first replace the paper and paper roll spindle. Then reverse the procedure used to remove it. Make sure all protrusions are aligned in the holes provided.

TYPING UNIT

Note: Computer Input/Output Sets having a keyboard lock mechanism — the keyboard must be removed from the base before the typing unit can be disassembled.

2.02 To remove typing unit (Figure 2), proceed as follows.

- (a) Remove cover assembly as described in 2.01.
- (b) Remove all plugs which connect the typing unit to the call control unit. Remove ground strap from ground tab on call control unit.

Note: On ASR Sets, remove the two leads that connect to the reader cable from the contact assembly.

(c) Insert screwdriver in slot of TP180977 H-plate and push to left against pressure of spring until plate is disengaged from universal lever. Remove H-plate. (See Figure 2)

(d) Lift typing unit from subbase using the following procedure.

- (1) Insert a screwdriver between the typing unit base casting and the subbase in the left rear of the typing unit.
- (2) Using the screwdriver as a lever, lift the left rear section of the typing unit until the left hand can be placed under the unit.
- (3) Grasp the extreme right side of the front carriage shaft and lift the typing unit from the subbase.

(e) To replace typing unit, reverse procedure used to remove it. Make sure typing unit is properly seated on rubber isolators and TP180831 answer-back bellcrank is under and aligned with HERE IS key. Replace plugs in proper receptacles on call control unit. Replace H-plate.

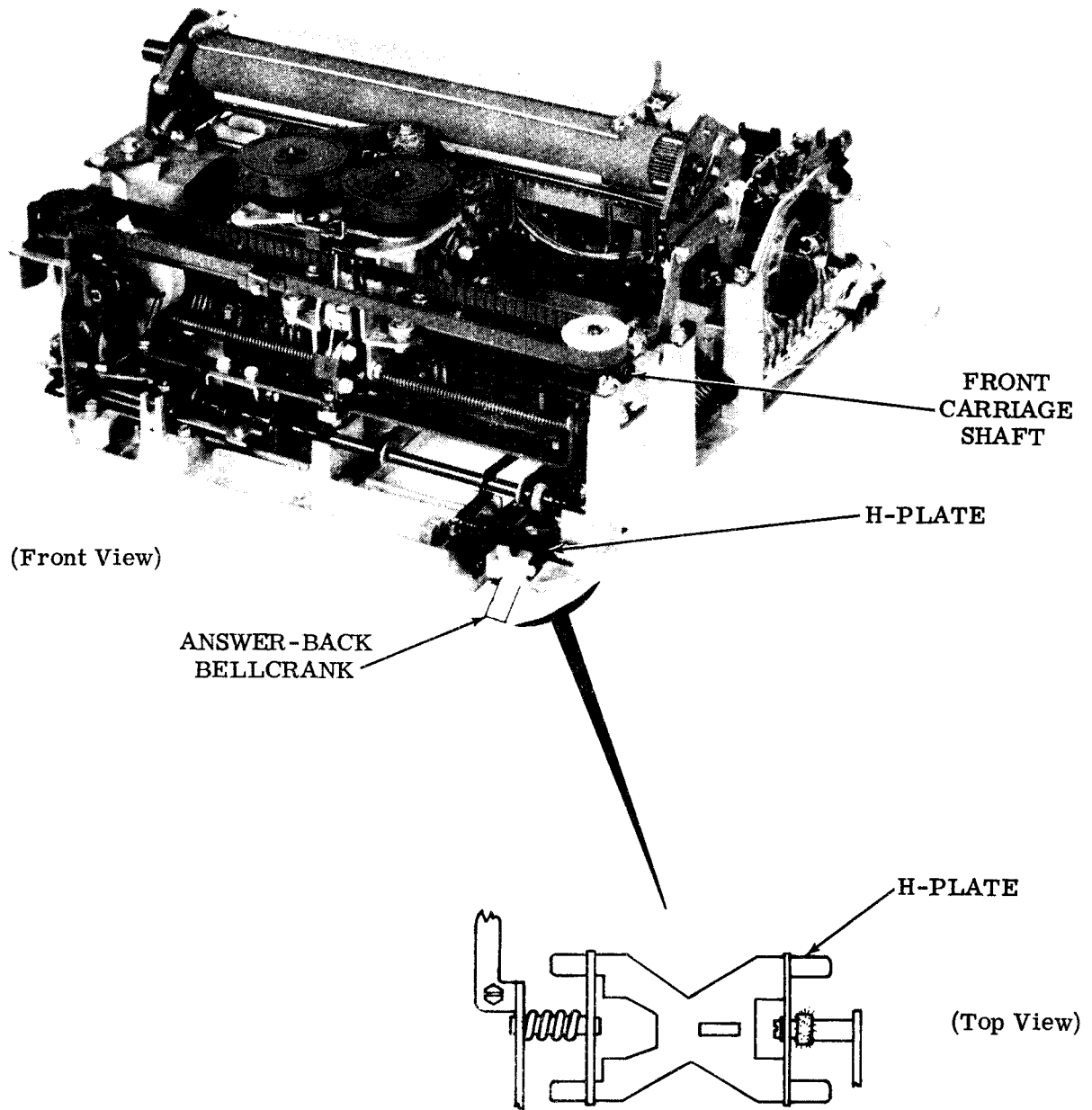

Figure 2 - Typing Unit

KEYBOARD

2.03 To remove the keyboard (Figure 3), proceed as follows.

- (a) Remove cover assembly as described in 2.01.
- (b) Remove the keyboard plug from its receptacle on the call control unit.
- (c) Temporarily remove the call control unit by removing the four TP121551 mounting screws.

- (d) Disengage the keyboard cable from the TP182531 cable clips on subbase.
- (e) Insert a screwdriver in slot of TP180977 H-plate and push to left against pressure of spring until H-plate is disengaged from the universal lever. Remove the H-plate.
- (f) Loosen the two TP180798 keyboard mounting screws. Slide keyboard assembly toward the rear and lift it from subbase.

Note: On Computer Input/Output Sets refer to 2.05 for removal of call control unit.

- (g) To replace keyboard, reverse procedure used to remove it.

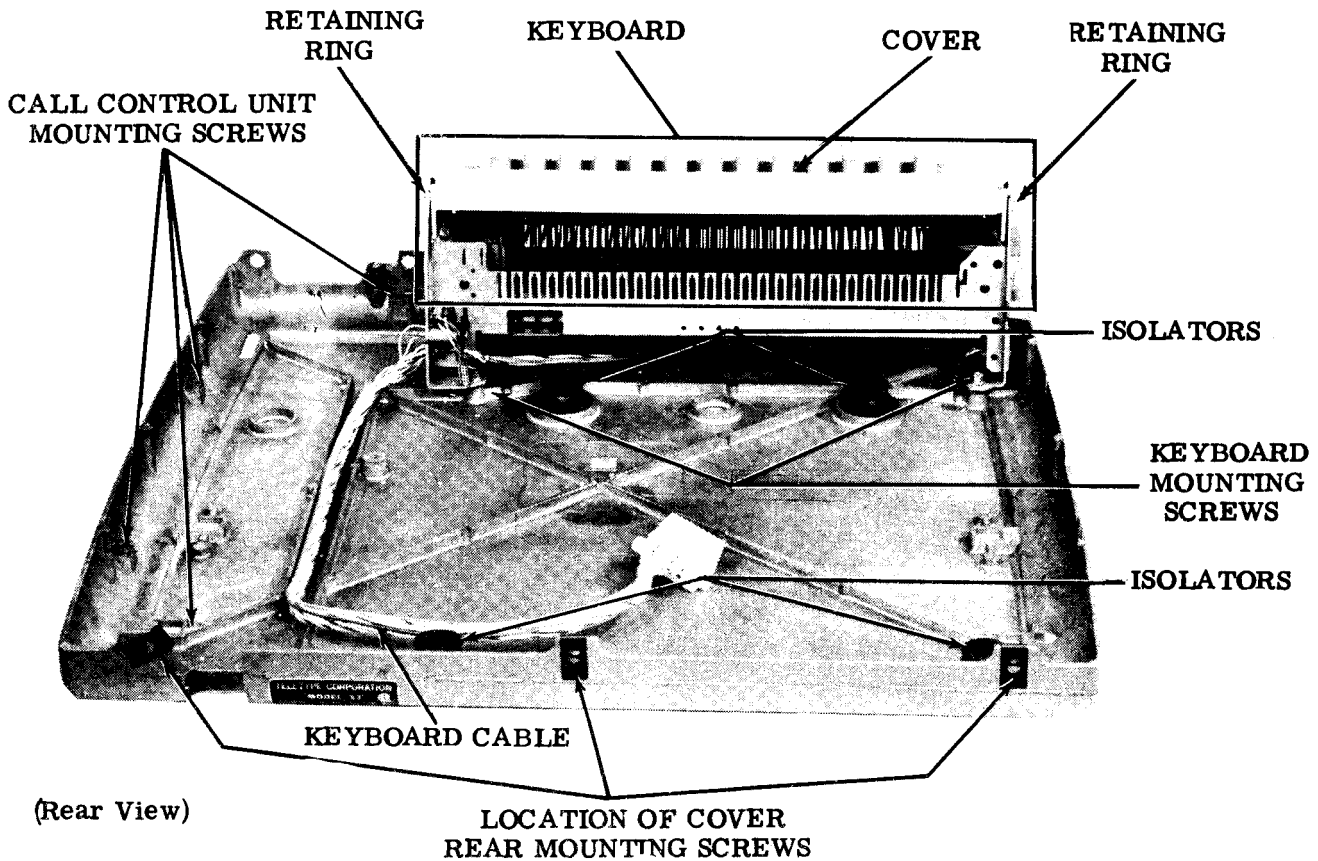

Figure 3 - Subbase With Keyboard

CALL CONTROL UNIT

3300 Series Coded Sets and 33 Sets

2.04 To remove the call control unit (Figure 3), proceed as follows.

- (a) Remove cover assembly as described in 2.01.

Note: If a speaker is used in conjunction with the call control unit, lift it off the sub-base and set it with the call control unit.

- (b) Remove all plugs from rear of call control unit.
- (c) Remove the four TP121551 mounting screws.
- (d) Remove ground strap.
- (e) Remove the call control unit.
- (f) To replace the call control unit, reverse the procedure used to remove it.

CAUTION: BE SURE THAT THE SPEAKER WIRES DO NOT BECOME ENTANGLED WITH THE BELL RINGER ADJUSTMENT LEVER.

Computer Input/Output Sets

2.05 To remove the call control unit, proceed as follows:

- (a) Remove cover assembly as described in 2.01.
- (b) Remove all plugs from the rear of the call control unit.
- (c) Remove ground strap.
- (d) Remove two screws at the right and one screw at the front of the call control unit.
- (e) Lift and slide the call control unit forward.
- (f) To replace the call control unit, engage the rear slot under the shoulder screw provided and slide to the rear and down. Reverse procedure used to remove it.

TAPE READER

3300 Series Coded Sets and Computer I/O Sets

2.06 To remove the tape reader and attached cable assembly, proceed as follows:

- (a) Remove cover assembly as described in 2.01.
- (b) Remove plugs no. 5 and no. 6 from the rear of the call control unit.
- (c) Disconnect the power pack connector.
- (d) Remove the two TP182726 push-on terminals from the tabs of the tape reader feed magnet contact assembly.
- (e) Remove the reader cable from under the typing unit casting. Remove any necessary cable clamps.
- (f) Remove TP119651 retaining ring from the TP183117 locking screw on tape readers so equipped. Then, remove the TP183117 locking screw from tape reader mounting bracket.
- (g) To replace the tape reader reverse the procedure used to remove it.

33 Sets

2.07 To remove the tape reader and attached cable assembly, proceed as follows.

- (a) Remove cover assembly as described in 2.01.
- (b) Remove tape reader plug marked "6" from receptacle in back of call control unit.

Note: On units with automatic reader control, also remove plug marked "5".

- (c) Remove plug from power pack.
- (d) Remove the two TP182726 push-on terminals from the tabs of the tape reader feed magnet contact assembly.
- (e) Remove any necessary cable clamps.
- (f) Remove the four TP121551 call control bracket mounting screws.

(g) Lift call control unit and remove tape reader cable which is located under the call control unit.

(h) Replace call control unit.

Note 1: Early Design Tape Readers: Remove the three TP181244 mounting screws, TP7002 flat washers, and TP124177 lock-washers from tape reader mounting bracket.

Note 2: Late Design Tape Readers: First remove the TP119651 retaining ring from the TP183117 locking screw on tape readers so equipped. Then, remove the TP183117 locking screw from tape reader mounting bracket.

(c) Remove the TP182805 nut plate from the inside surface of the front wall of the typing unit base casting.

(d) Remove the codebar extensions from their respective codebar slots while removing the tape punch base casting from the carriage shaft.

(e) To replace the tape punch to the typing unit base casting, reverse the procedure used to remove it. Prior to replacing the tape punch to the left side of the typing unit base casting, manually set up the typing unit so that all codebars are in the marking position.

2.09 Late Design (Sheet Steel Frame): To remove the tape punch from the typing unit base casting (Figure 5), proceed as follows.

PUNCH

Note: The 3300 Series Coded Sets and Computer Input/Output Sets are equipped with late design tape punches. The 33 sets may be equipped with either early design or late design tape punches.

2.08 Early Design (Aluminum Casting): To remove the tape punch from the typing unit base casting (Figure 4), proceed as follows.

(a) Unhook the TP3864 spring from the TP182894 drive link and rotate drive link out of the way.

(b) Remove the three screws which secure the tape punch base casting to the typing unit base casting in the following order:

First, the TP181246 screw.

Second, the rear TP182891.

Finally, the most forward TP182891 screw.

(a) Unhook the spring from the drive link and rotate drive link out of the way.

(b) Remove two bracket connecting screws.

(c) Remove the mounting screw that holds the platen mounting post to the plate.

(d) Remove the codebar extensions from their respective codebar slots while also removing the tape punch from the typing unit.

(e) To replace the tape punch to the typing unit base casting, reverse the procedure used to remove it. Prior to replacing the tape punch to the left side of the typing unit base casting, manually set up the typing unit so that all codebars are in the marking position. Make sure the top surfaces of the mounting brackets are parallel to each other.

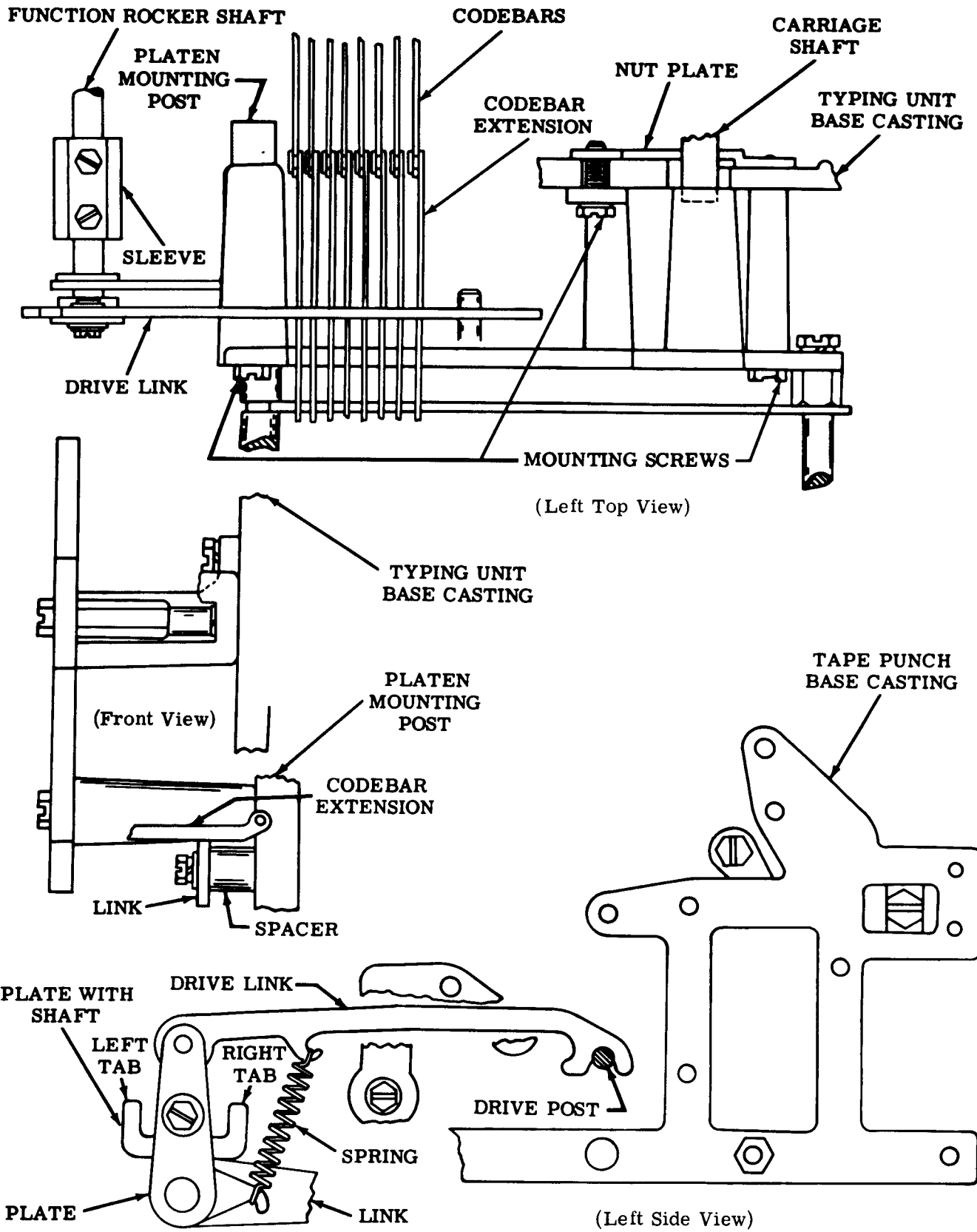

Figure 4 - Tape Punch (Early Design)

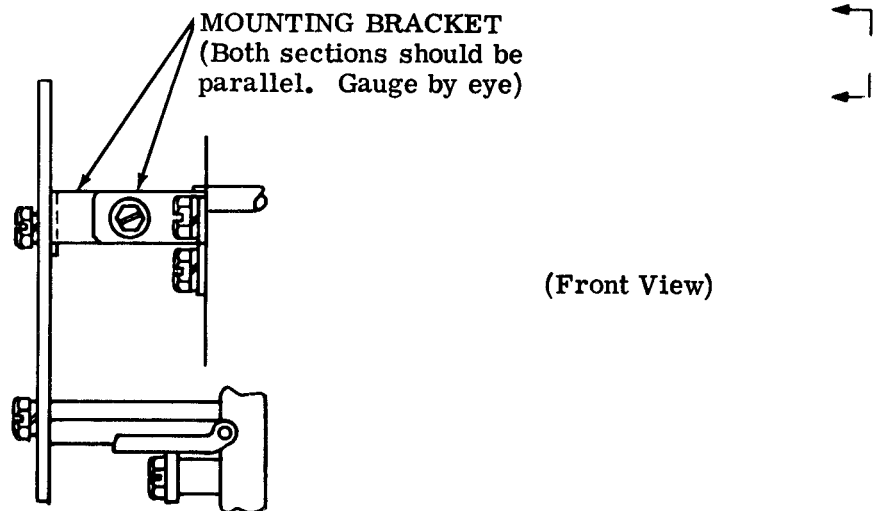
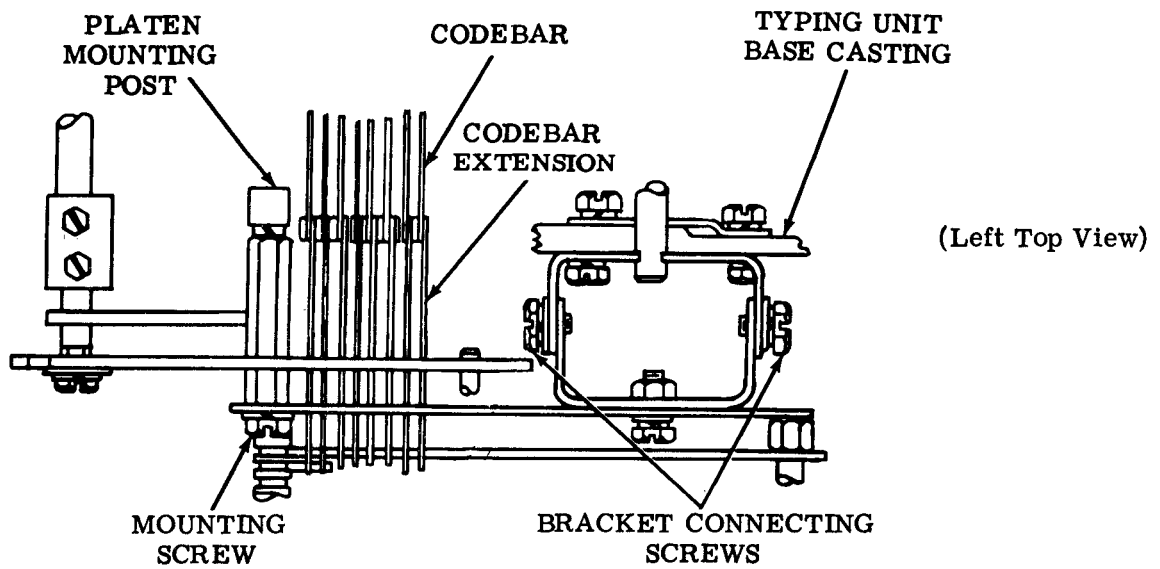
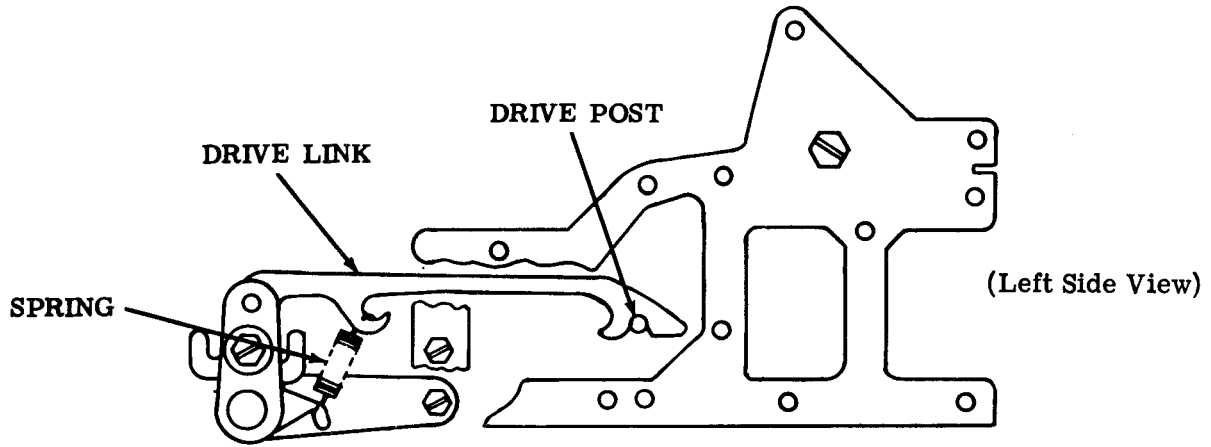

Figure 5 - Tape Punch (Late Design)