

BULLETIN 1184B

33 PAGE PRINTER SET

(ASR, KSR AND RO)

PARTS

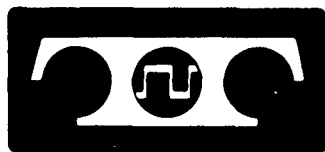

TELETYPE[®]
CORPORATION

5555 TOUHY AVENUE, SKOKIE, ILLINOIS

TABLE OF CONTENTS

SECTION	TITLE	ISSUE	DATE
574-121-800TC	33 Keyboard (UK)	*5	December 1970
574-122-800TC	33 Typing Unit (UP)	*7	February 1971
574-123-800TC	33 Call Control Unit (UCC)	*6	December 1970
574-124-800TC	33 Reader (UX)	*4	December 1970
574-125-800TC	33 Tape Punch (UPE)	*4	December 1970
574-126-800TC	33 Cover and Table	*5	December 1970

*Indicates revised sections

33 KEYBOARD (UK)

PARTS

FIGURE	CONTENTS	PAGE
1	Keyboard Basket and Contact Block	2
2	185801 Modification Kit to Provide Locking for Keyboard	3
3	186752 Modification Kit to Provide Locking for Keyboard	3
4	Keyboard Covers	4
5	Keytops	5
6	Keylevers	6
7	Codebar Mechanism	7
8	Codebar Mechanism for Units Equipped with Even Parity	8
9	Codebar Mechanism for Numerical Keyboard	9
10	Reset Mechanism for Self-Contained and Solenoid Reset Keyboards	10
11	Reset Mechanism for Even Parity Keyboard	11
12	Cover for Self-Contained and Solenoid Reset Keyboards	12
	Numerical Index	13

**Denotes a painted part.
HF-Light Olive Gray Smooth Vinyl.

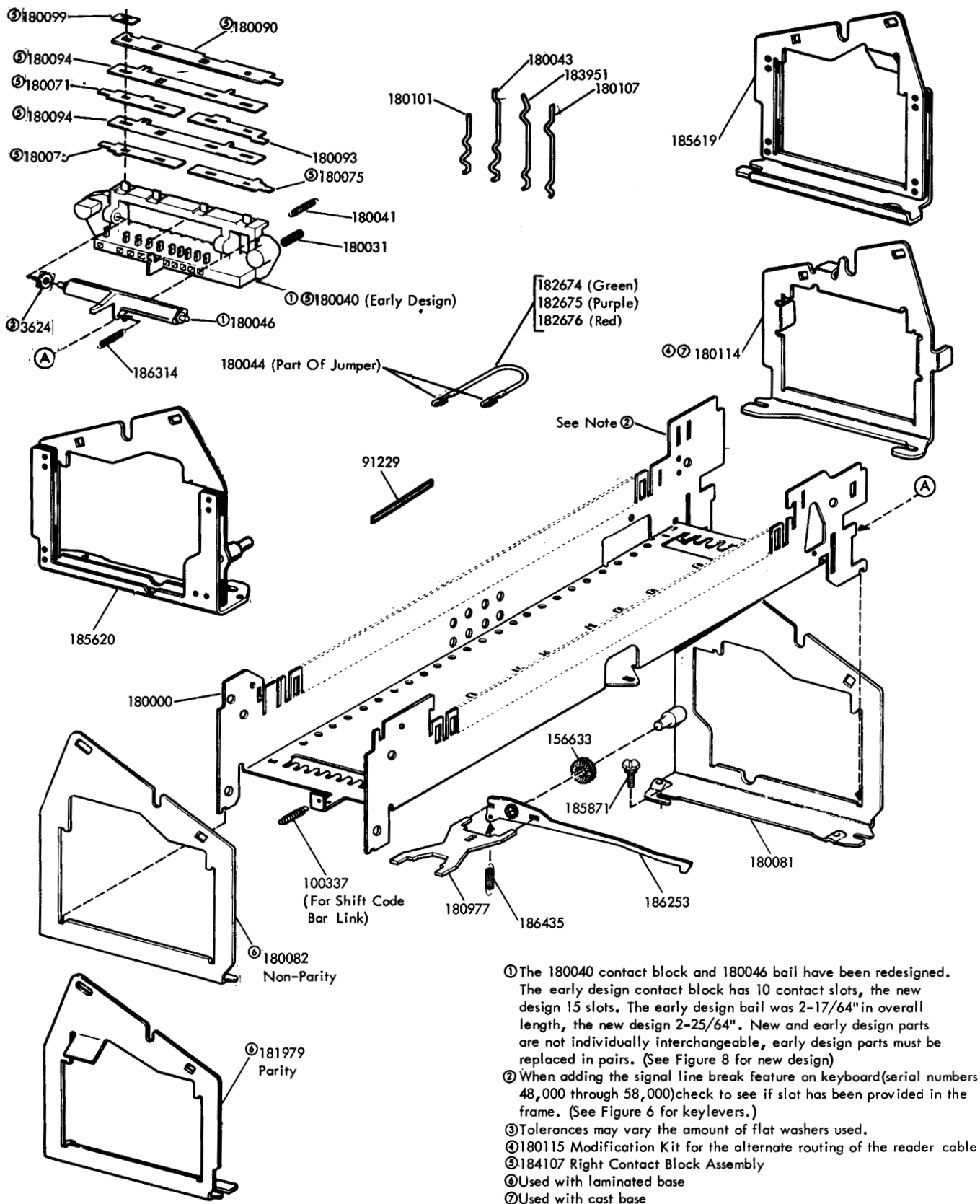

FIGURE 1. KEYBOARD BASKET AND CONTACT BLOCK

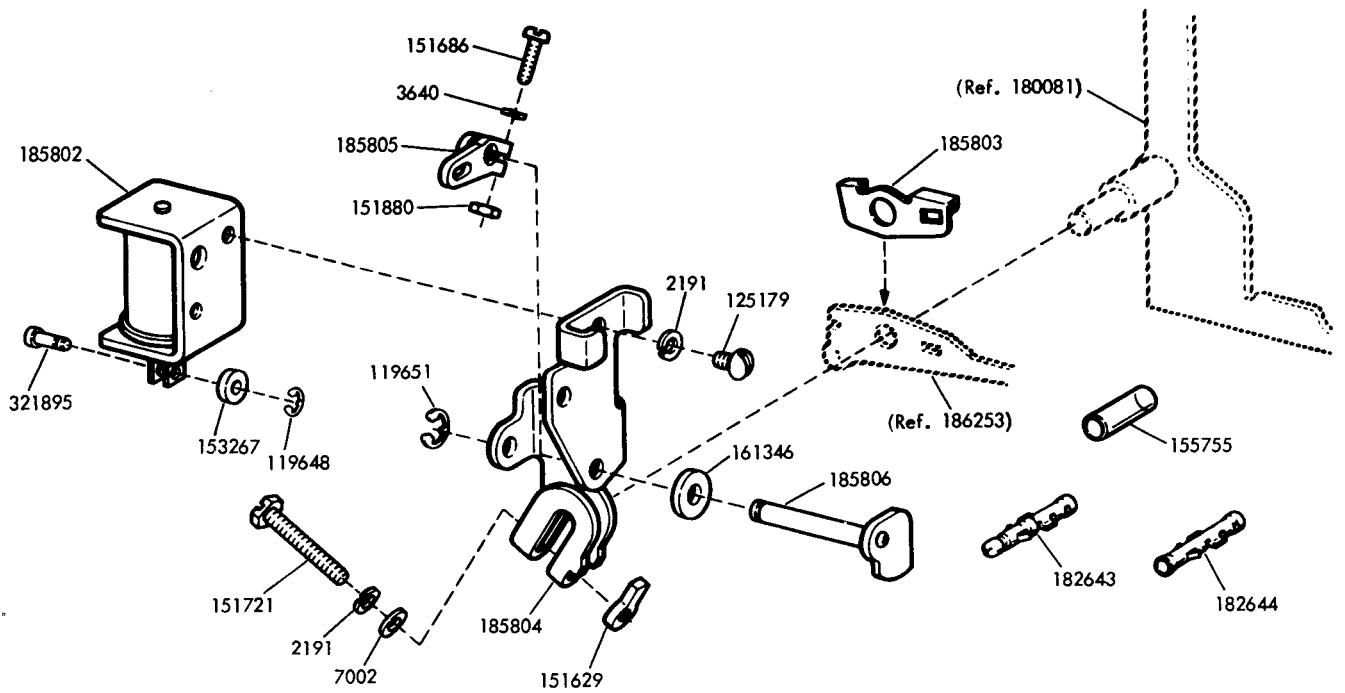

FIGURE 2. 185801 MODIFICATION KIT TO PROVIDE LOCKING FOR KEYBOARD

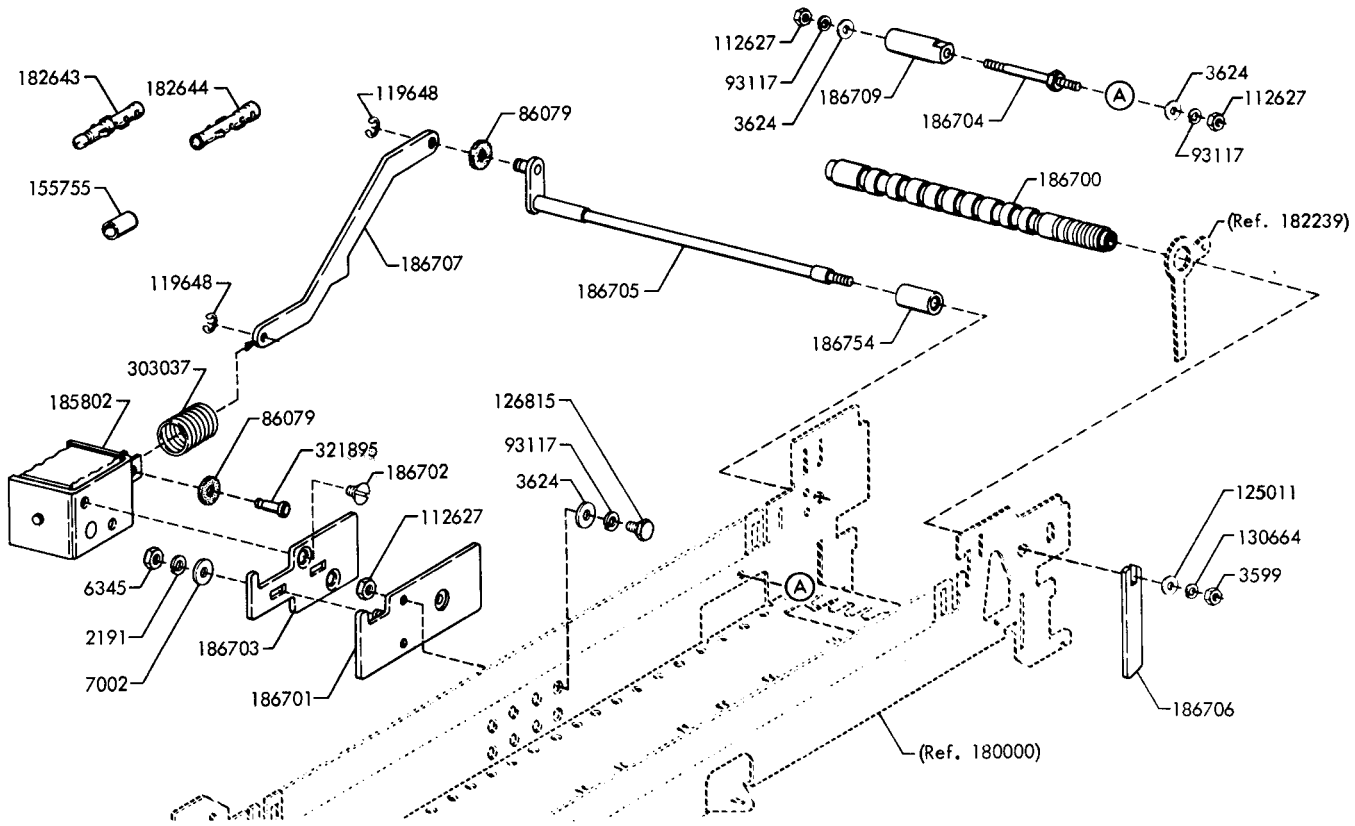

FIGURE 3. 186752 MODIFICATION KIT TO PROVIDE LOCKING FOR KEYBOARD

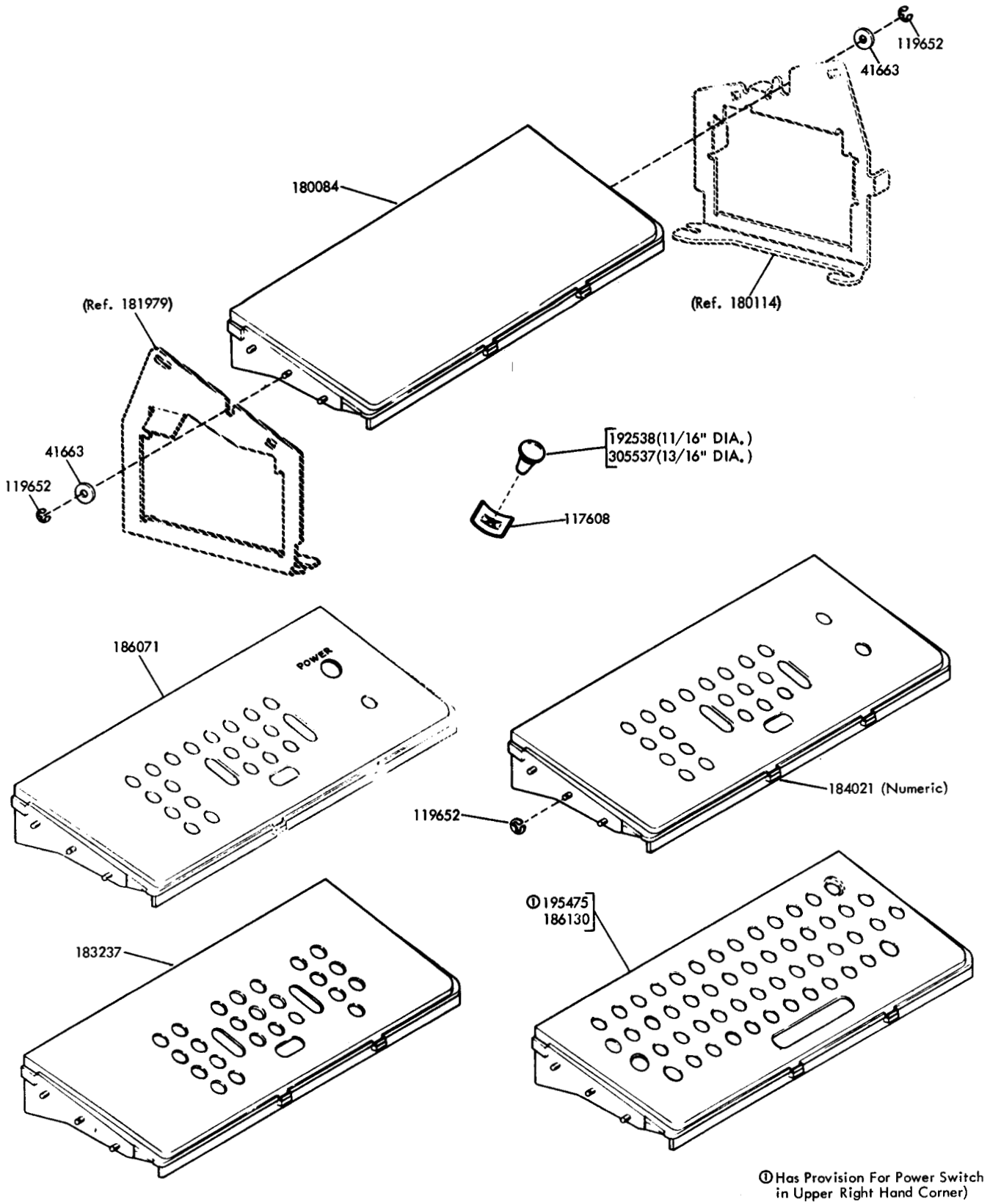
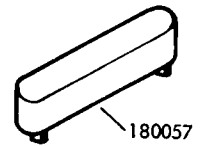
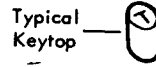
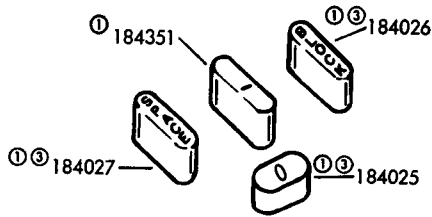

FIGURE 4. KEYBOARD COVERS



Keytop Description			Keytop Description			Keytop Description		
UNSHIFT	SHIFT	Part Number	UNSHIFT	SHIFT	Part Number	UNSHIFT	SHIFT	Part Number
A		180181	P	@	180180	8		①③ 184341
A	SOM	*183891	Q		180171	9)	180168
A		①③ 184343	Q	X ON	*183888	9		①③ 184342
B		180194	Q	X-ON	184869	0		180169
B		①③ 184344	Q	RLF	185160	∅		180374
C		180192	R	TAPE	180174	-	=	180170
C		①③ 184345	R		180260	,	<	180197
C	ETX	185165	R	FS	185161	.	>	180198
D	EOT	180183	S		180282	;	+	180199
D		180278	S	X OFF	180182	/	?	180200
D		①③ 184346	S	X OFF	*183892	:	*	180205
E	WRU	180173	S		③ 185374	(No Symbol)		① 180299
E		180259	T	TAPE	180175	-		180336
E	WRU	*183889	T		180261		•	180335
F	RU	180184	T	PR	185162		,	180418
F		180273	T		③ 185395		.	180419
G	BELL	180185	U		180177	/	■	184895
G		180274	V		180193	RUB OUT		①③ 180201
G	BELL	*183890	W		180172	RETURN		①③ 180202
H		180186	X		180191	LINE FEED		①③ 180203
H	BS	185163	X		③ 185396	HERE IS		180206
I	TAB	180178	Y		180176	BREAK		180207
I		180262	Z		180190	REPT		①③ 180208
J		180187	1	!	180160	ALT MODE		180257
K	VT	180188	1		①③ 184334	ESC		180382
K		180280	1		180264	EOT		①③ 180440
K	□	180383	2	"	180161	DIV		① 180441
K	I	185090	2		①③ 184335	STORE		① 180442
L	FORM	180189	3	#	180162	TYPE ORD		① 180443
L		180281	3		①③ 184336	SECT		① 180444
L	\	180385	4	\$	180163	SHIFT		180061
L	FORM	185164	4		①③ 184337	CTRL		181253
M		180196	5	%	180164	CTRL		② 181971
M	□	180384	5		①③ 184338	FS		① 184815
M	I	185093	6	&	180165	GS		① 184816
N	↑	180195	6		①③ 184339	RS		① 184817
N	BLK	185092	7	'	180166	US		① 184818
N	∧	185150	7		①③ 184340	CLR KYBD		184734
O	←	180179	8	(180167	CTRL		185159
O	└	185089				TAB		180373

NOTE:
 All Keytops are gray with white characters except as noted.
 *Gray Keytops with yellow characters.
 ① Used on Numeric Keyboard.
 ② Used with parity control.
 ③ Used on Numeric Self-Contained Keyboard

FIGURE 5. KEYTOPS

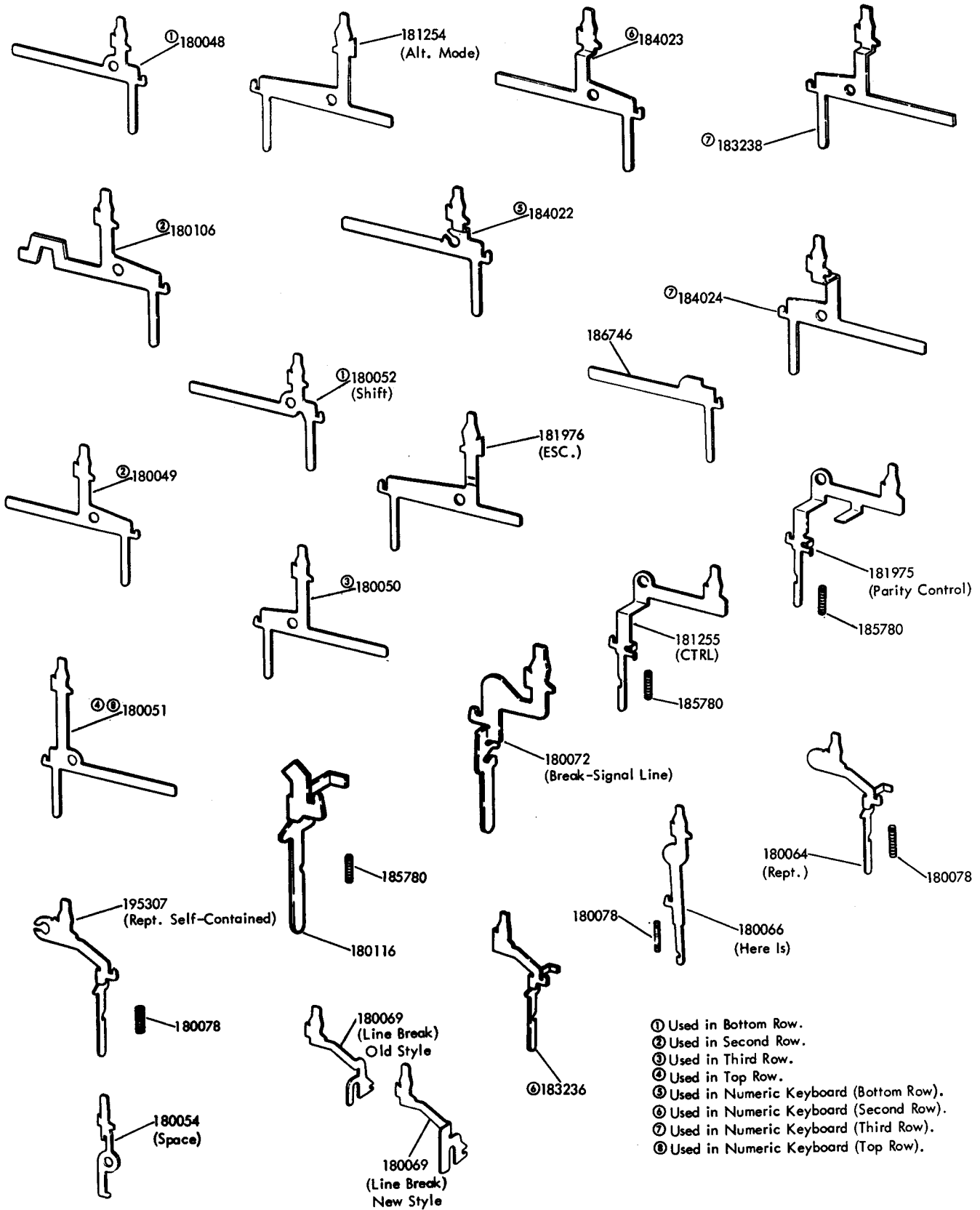

FIGURE 6. KEYLEVERS

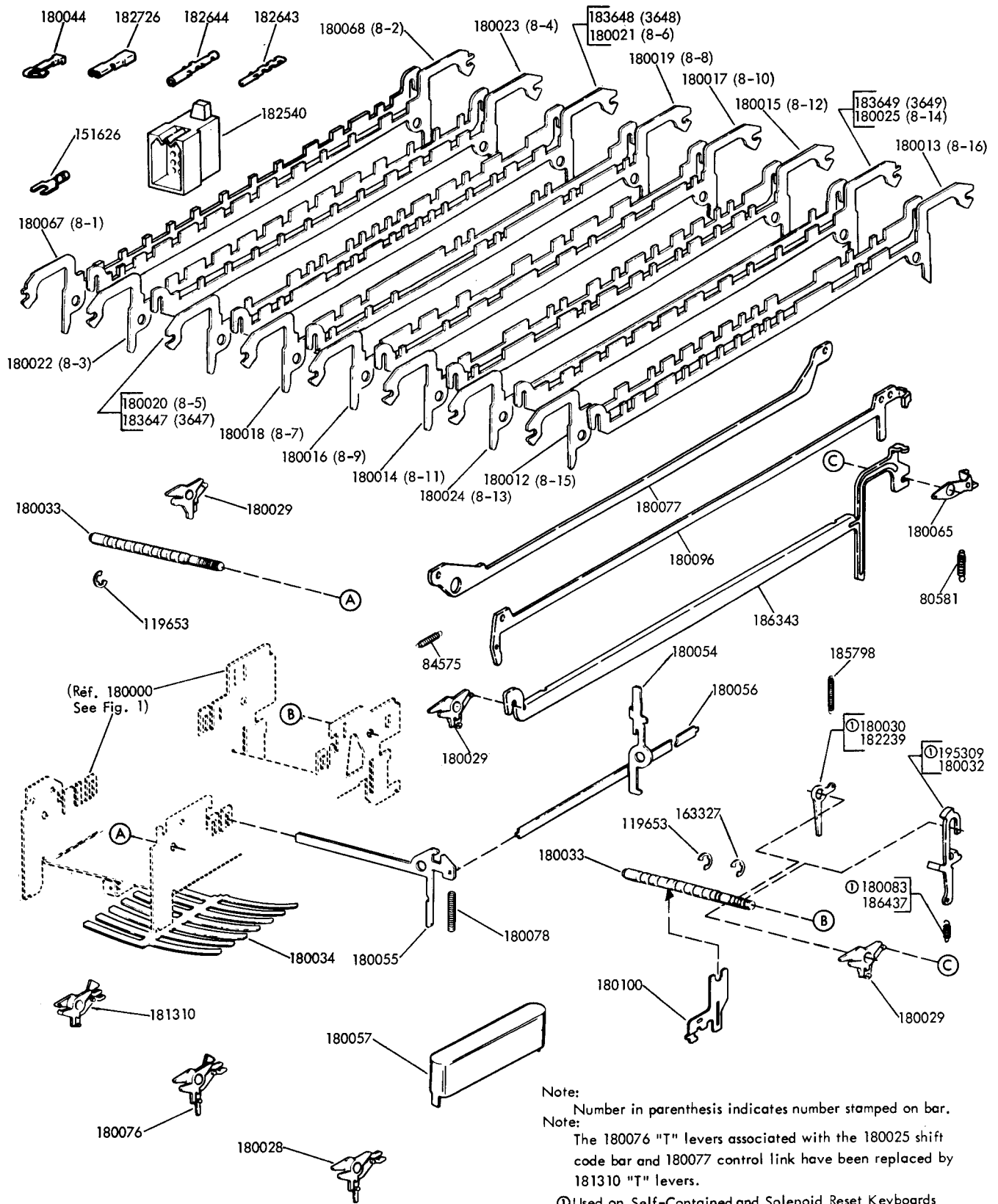

FIGURE 7. CODE BAR MECHANISM

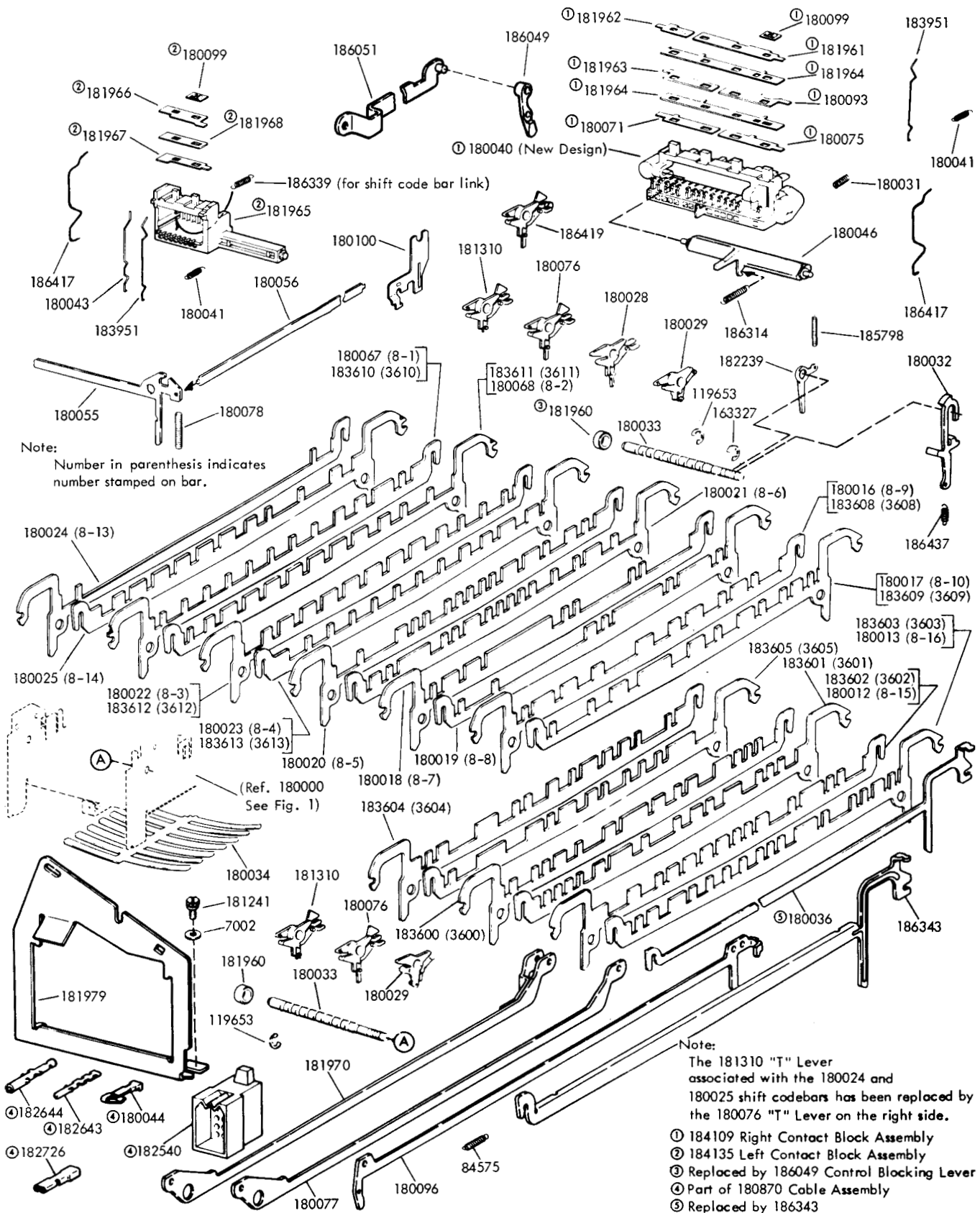

FIGURE 8. CODE BAR MECHANISM FOR UNITS EQUIPPED WITH EVEN PARITY

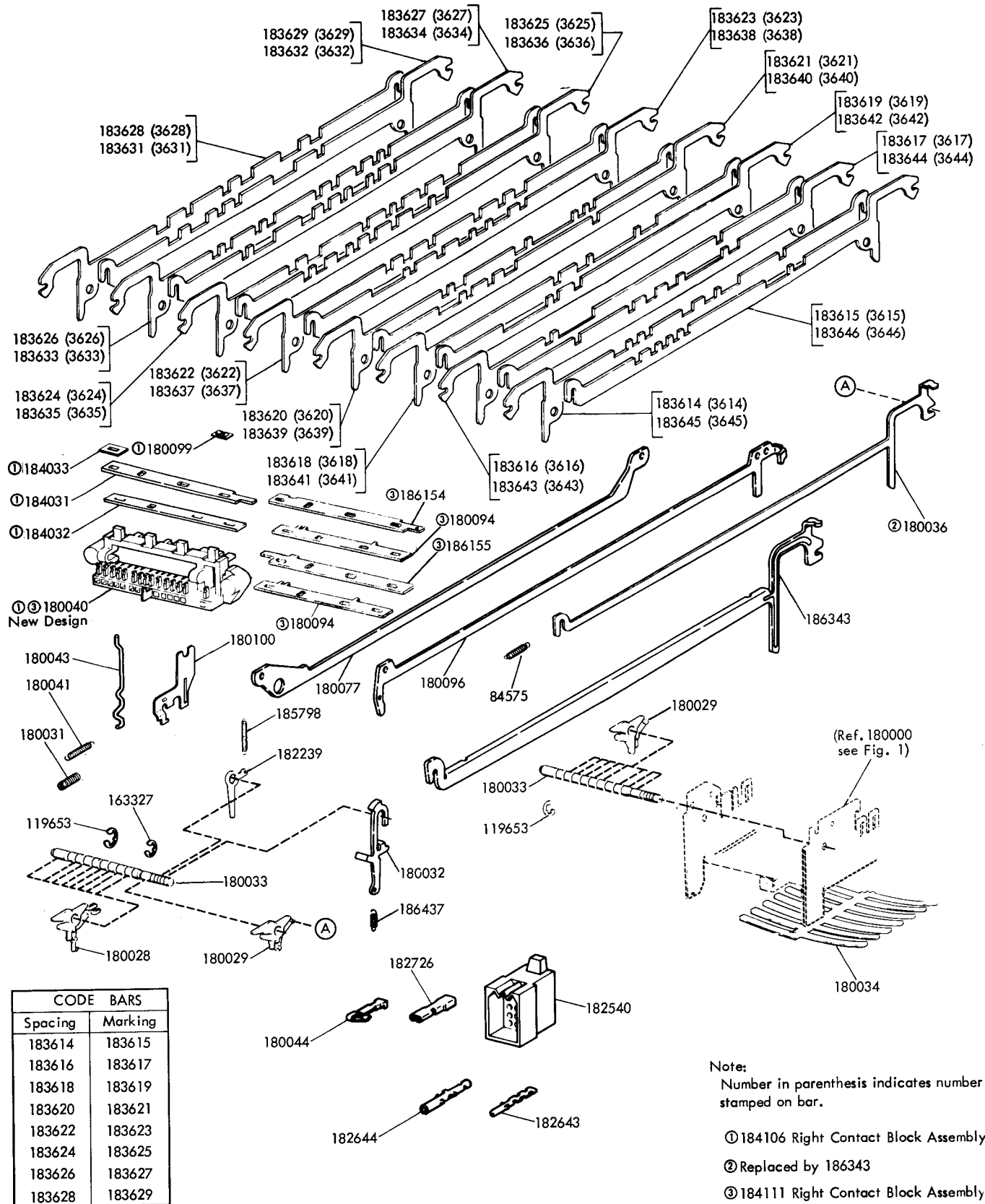

FIGURE 9. CODEBAR MECHANISM FOR NUMERIC KEYBOARD

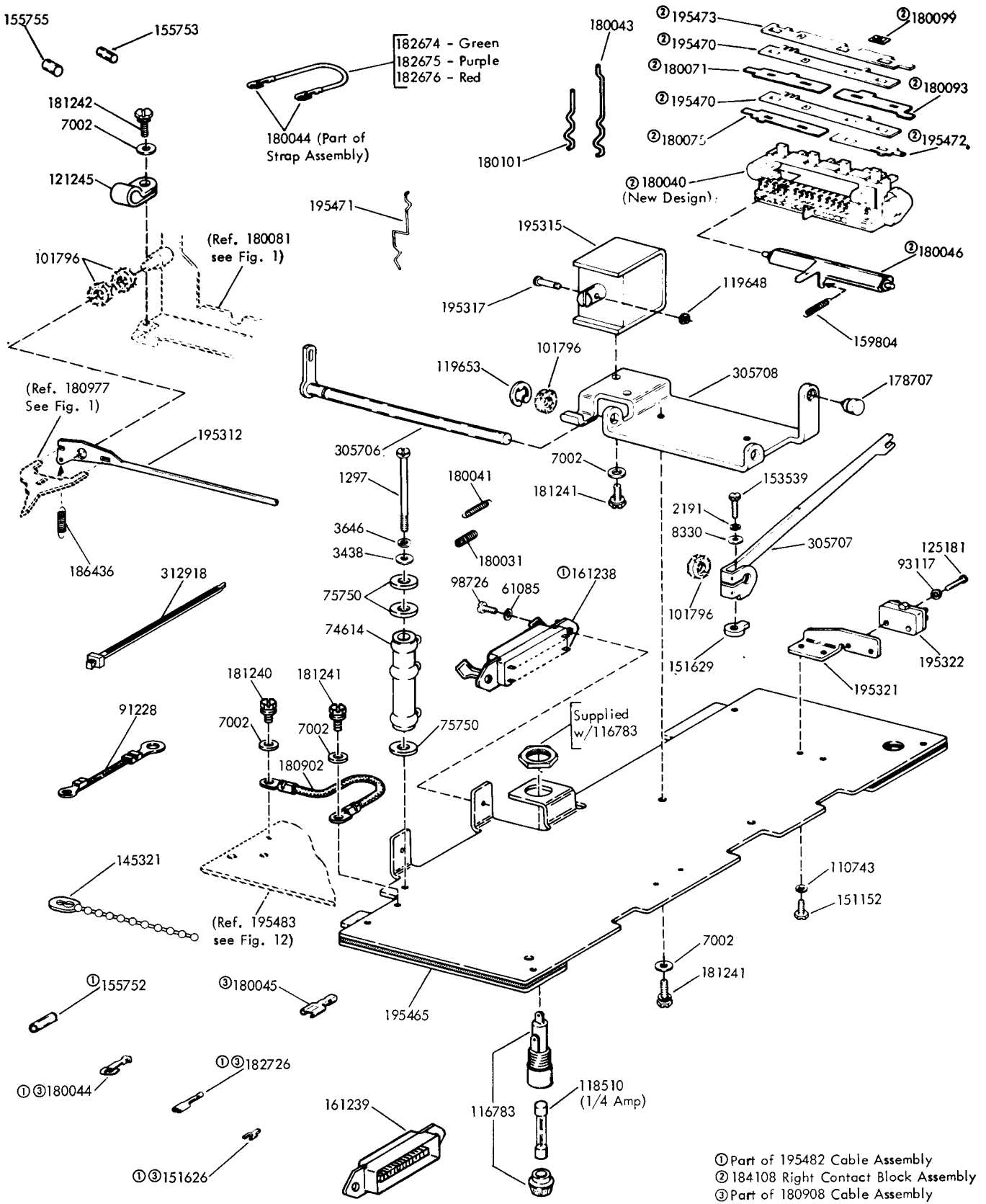

FIGURE 10. RESET MECHANISM FOR SELF-CONTAINED AND SOLENOID RESET KEYBOARDS

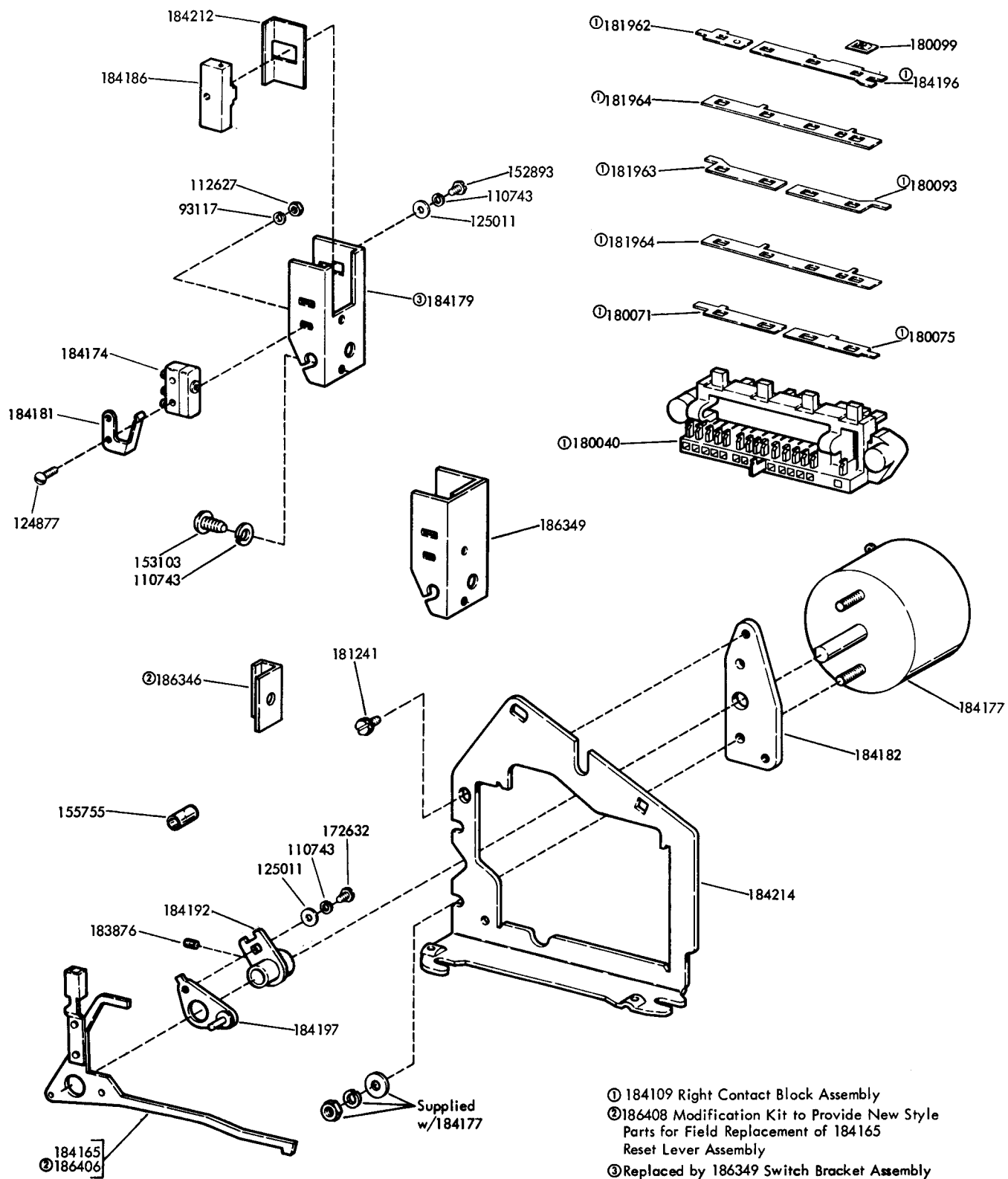
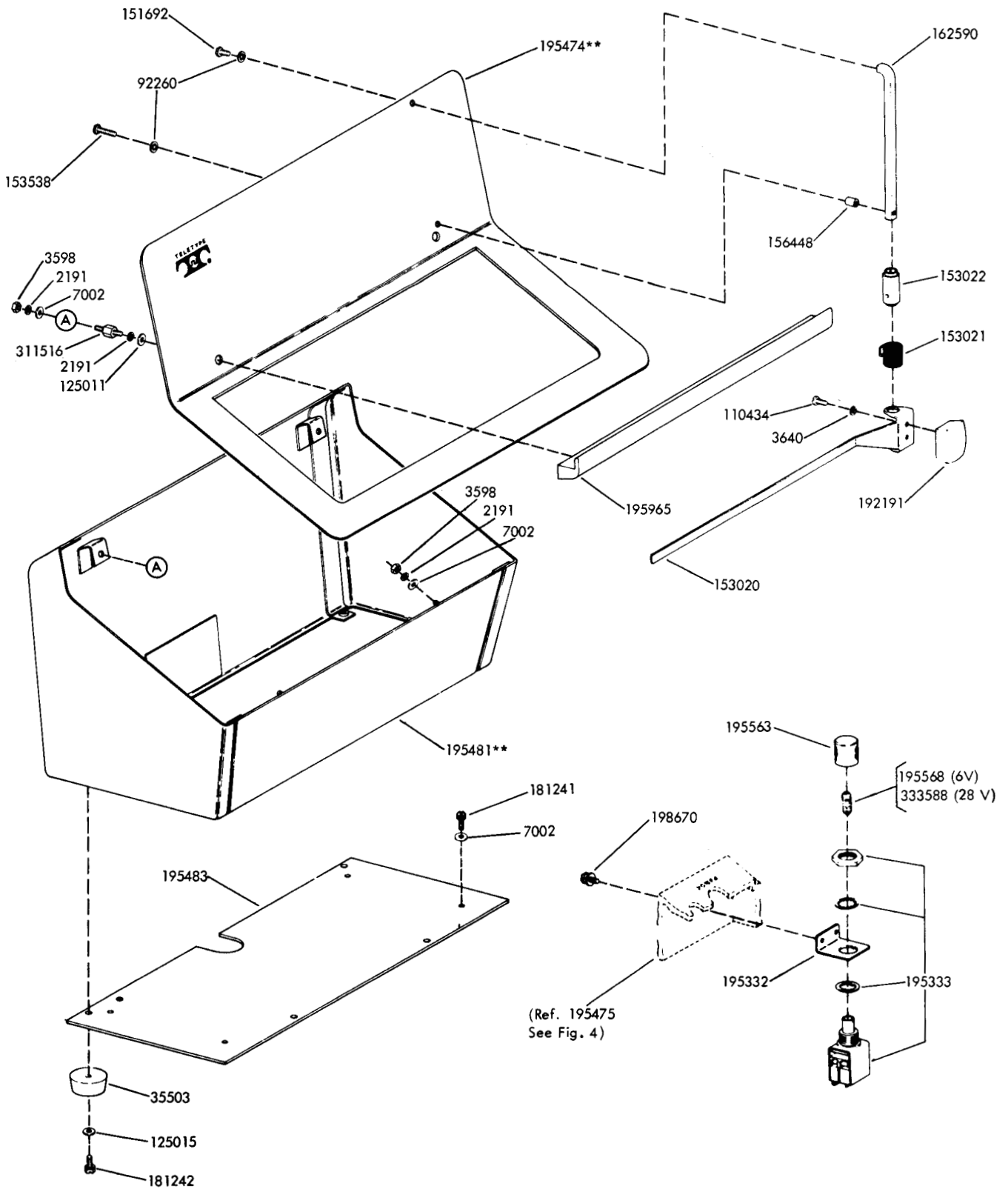

FIGURE 11. RESET MECHANISM FOR EVEN PARITY KEYBOARD



**Refer to Page 1 for Finish Suffix

FIGURE 12. COVER FOR SELF-CONTAINED AND SOLENOID RESET KEYBOARDS

NUMERICAL INDEX

Part Number	Description and Page Number	Part Number	Description and Page Number	Part Number	Description and Page Number
1297	Screw, 6-40 x 2-7/16 Fil 10	151692	Screw, 6-40 x 3/16 Fil 12	180033	Shaft 7,8,9
2191	Lockwasher 3,10,12	151721	Screw, 6-40 x 3/4 Hex 3	180034	Spring, Flat 7,8,9
3438	Washer, Flat 10	151880	Nut, 4-40 Hex 3	180036	Bar, Universal Code 8,9
3598	Nut, 6-40 Hex 12	152893	Screw, 4040 x 1/4 Hex 11	180040	Block, Contact 2,8,9,10, 11
3599	Nut, 4-40 Hex 3	153020	Guide, Line 12	180041	Spring 2,8,9,10
3624	Washer, Flat 2,3	153021	Spring, Torsion 12	180043	Wire, Contact 2,8,9,10
3640	Lockwasher 3,12	153022	Bushing 12	180044	Terminal, Tab Type 2,7,8, 9,10
3646	Lockwasher 10	153103	Screw, 4-40 Self-Tapping 11	180045	Terminal, Tab Type 10
6345	Nut, 6-32 Hex 3	153267	Washer, Felt 3	180046	Bail, Contact Reset 2,8, 10
7002	Washer, Flat 3,8,10,12	153538	Screw, 6-40 x 7/16 Hex 12	180048	Keylever 6
8330	Washer, Flat 10	153539	Screw, 6-40 x 11/16 Hex 10	180049	Keylever 6
35503	Foot, Rubber 12	155752	Sleeve, 5/64 ID x 1/2 Lg Insulating 10	180050	Keylever 6
41663	Washer, Flat 4	155753	Sleeve, 1/8 ID x 1/2 Lg Insulating 10	180051	Keylever 6
61085	Lockwasher 10	155755	Sleeve, 11/64 ID x 5/8 Lg Insulating 3,10,11	180052	Keylever, Shift 6
74614	Resistor, 2,600 Ohm 10	156448	Bushing 12	180054	Keylever, Spacebar 6,7
75750	Washer, Insulating 10	156633	Washer, Felt 2	180055	Keylever, Spacebar 7,8
80581	Spring 7	159804	Spring 10	180056	Link, Space 7,8
84575	Spring 7,8,9	161238	Connector, 36 Pt Receptacle 10	180057	Spacebar 5,7
86079	Washer, Felt 3	161239	Connector, 36 Pt Plug 10	180061	Keytop 5
91228	Strap, 2-1/2" Braided 10	161346	Washer, Felt 3	180064	Keylever, Repeat 6
91229	Strap, 2" Braided 2	162590	Shaft 12	180065	Lever, Link Break 7
92260	Lockwasher 12	163327	Ring, Retaining 7,8,9	180066	Keylever 6
93117	Lockwasher 3,10,11	172632	Screw, 4-40 x 3/16 Hex 11	180067	Bar, No. 7 Rear Code 7,8
98726	Screw, 3-48 x 1/4 Fil 10	178707	Bumper, Rubber 10	180068	Bar, No. 7 Front Code 7,8
100337	Spring 2	180000	Frame, Keyboard 2,3,7,8,9	180069	Keylever, Line Break 6
101796	Washer, Felt 10	180012	Codebar No. 1 Rear 7,8	180071	Terminal 2,8,10,11
110434	Screw, 4-40 x 3/16 Fil 12	180013	Codebar No. 1 Front 7,8	180072	Keylever, Line Break 6
110743	Lockwasher 10,11	180014	Codebar No. 2 Rear 7	180075	Terminal, Line Break 2,8, 10,11
112627	Nut, 2-56 Hex 3,11	180015	Codebar No. 2 Front 7	180076	Lever, No. 5 Pulse 7,8
116783	Holder, Fuse 10	180016	Codebar No. 3 Rear 7,8	180077	Link 7,8,9
117608	Nut, Speed 4	180017	Codebar No. 3 Front 7,8	180078	Spring, Compression 6,7,8
118510	Fuse, 1/4 Amp 10	180018	Codebar No. 4 Rear 7,8	180081	Bracket, Right Keyboard 2,3,10
119648	Ring, Retaining 3,10	180019	Codebar No. 4 Front 7,8	180082	Bracket, Left Keyboard 2
119651	Ring, Retaining 3	180020	Codebar No. 5 Rear 7,8	180083	Spring 7
119652	Ring, Retaining 4	180021	Codebar No. 5 Front 7,8	180084	Cover, Keyboard 4
119653	Ring, Retaining 7,8,9,10	180022	Codebar No. 6 Rear 7,8	180090	Terminal, Common 2
121245	Clamp, 5/16 ID Cable 10	180023	Codebar No. 5 Front 7,8	180093	Terminal 2,8,10,11
124877	Screw, 2-56 x 1/2 Rd 11	180024	Codebar No. 5 Rear 7,8	180094	Insulator 2,9
125011	Washer, Flat 3,11,12	180025	Codebar No. 5 Front 7,8	180096	Link 7,8,9
125015	Washer, Flat 12	180028	Lever 7,8,9	180099	Fastener 2,8,9,10,11
125179	Screw, 6-32 x 3/16 Rd 3	180029	Lever 7,8,9	180100	Guide 7,8,9
125181	Screw, 2-56 x 3/8 Fil 10	180030	Lever, Latch 7	180101	Wire, Contact 2,10
126815	Screw, 2-56 x 15/64 Hex 3	180031	Spring, Compression 2,8, 9,10	180106	Keylever 6
130664	Lockwasher 3	180032	Lever, Non-Repeat 7,8,9	180107	Detent 2
145321	Tie, Cable 10			180114	Bracket, Left Keyboard 2,4
151152	Screw, 4-40 x 3/16 Hex 10				
151626	Terminal 7,10				
151629	Nut, 6-40 Lug 3,10				
151686	Screw, 6-40 x 3/8 Fil 3				

NUMERICAL INDEX (Continued)

Part Number	Description and Page Number	Part Number	Description and Page Number	Part Number	Description and Page Number
180115	Modification Kit 2	180259	Keytop 5	181968	Insulator 8
180116	Keylever 6	180260	Keytop 5	181970	Link w/Extension 8
180160	Keytop 5	180261	Keytop 5	181971	Keytop 5
180161	Keytop 5	180262	Keytop 5	181975	Keylever 6
180162	Keytop 5	180264	Keytop 5	181976	Keylever 6
180163	Keytop 5	180273	Keytop 5	181979	Bracket, Left Keyboard 2,4,8
180164	Keytop 5	180274	Keytop 5	182239	Latchlever 3,7,8,9
180165	Keytop 5	180278	Keytop 5	182540	Connector, 15 Pt Plug Type 7,8,9
180166	Keytop 5	180280	Keytop 5	182643	Terminal, Plug Type 3,7,8,9
180167	Keytop 5	180281	Keytop 5	182644	Terminal, Receptacle Type 3,7,8,9
180168	Keytop 5	180282	Keytop 5	182674	Jumper, 2-1/4" Green 2,10
180169	Keytop 5	180299	Keytop 5	182675	Jumper, 2-1/4" Purple 2,10
180170	Keytop 5	180335	Keytop 5	182676	Jumper, 2-1/4" Red 2,10
180171	Keytop 5	180336	Keytop 5	182726	Terminal, Receptacle Type 7,8,9,10
180172	Keytop 5	180373	Keytop 5	183236	Keylever, Repeat 6
180173	Keytop 5	180374	Keytop 5	183237	Cover, Keyboard 4
180174	Keytop 5	180382	Keytop 5	183238	Keylever 6
180175	Keytop 5	180383	Keytop 5	183600	Codebar 8
180176	Keytop 5	180384	Keytop 5	183601	Codebar 8
180177	Keytop 5	180385	Keytop 5	183602	Codebar 8
180178	Keytop 5	180418	Keytop 5	183603	Codebar 8
180179	Keytop 5	180419	Keytop 5	183604	Codebar 8
180180	Keytop 5	180440	Keytop 5	183605	Codebar 8
180181	Keytop 5	180441	Keytop 5	183608	Codebar 8
180182	Keytop 5	180442	Keytop 5	183609	Codebar 8
180183	Keytop 5	180443	Keytop 5	183610	Codebar 8
180184	Keytop 5	180444	Keytop 5	183611	Codebar 8
180185	Keytop 5	180870	Cable Assembly 8	183612	Codebar 8
180186	Keytop 5	180902	Jumper, 3-1/2 In. Braided 10	183613	Codebar 8
180187	Keytop 5	180908	Cable Assembly 10	183614	Codebar 9
180188	Keytop 5	180977	Plate w/Stud 2,10	183615	Codebar 9
180189	Keytop 5	181240	Screw, w/Lockwasher 6-40 x 3/16 Hex	183616	Codebar 9
180190	Keytop 5	181241	Screw, w/Lockwasher, 6-40 x 1/4 Hex 8,10,11,12	183617	Codebar 9
180191	Keytop 5	181242	Screw, w/Lockwasher, 6-40 x 5/16 Hex 10,12	183618	Codebar 9
180192	Keytop 5	181253	Keytop 5	183619	Codebar 9
180193	Keytop 5	181254	Keylever 6	183620	Codebar 9
180194	Keytop 5	181255	Keylever 6	183621	Codebar 9
180195	Keytop 5	181310	Lever 7,8	183622	Codebar 9
180196	Keytop 5	181860	Spacer, .144" Thk 8	183623	Codebar 9
180197	Keytop 5	181861	Terminal 8	183624	Codebar 9
180198	Keytop 5	181960	Spacer, .144" Thk 8	183625	Codebar 9
180199	Keytop 5	181962	Terminal 8,11	183626	Codebar 9
180200	Keytop 5	181963	Terminal, Parity 8,11	183627	Codebar 9
180201	Keytop 5	181964	Insulator 8,11	183628	Codebar 9
180202	Keytop 5	181965	Block, Contact 8		
180203	Keytop 5	181966	Terminal 8		
180205	Keytop 5	181967	Terminal 8		
180206	Keytop 5				
180207	Keytop 5				
180208	Keytop 5				
180257	Keytop 5				

NUMERICAL INDEX (Continued)

Part Number	Description and Page Number	Part Number	Description and Page Number	Part Number	Description and Page Number
183629	Codebar 9	184177	Solenoid, Rotary 11	185802	Solenoid 3
183631	Codebar 9	184179	Bracket 11	185803	Clip 3
183632	Codebar 9	184181	Actuator 11	185804	Bracket 3
183633	Codebar 9	184182	Plate 11	185805	Lever 3
183634	Codebar 9	184186	Switch, Reed 11	185806	Shaft 3
183635	Codebar 9	184192	Plate w/Hub 11	185871	Screw w/Lockwasher, 8-32 x 3/8 Hex 2
183636	Codebar 9	184196	Terminal 11	186049	Lever 8
183637	Codebar 9	184197	Plate w/Stud 11	186051	Link 8
183638	Codebar 9	184212	Guide 11	186071	Cover 4
183639	Codebar 9	184214	Bracket, Right 11	186130	Cover 4
183640	Codebar 9	184334	Keytop 5	186154	Terminal 9
183641	Codebar 9	184335	Keytop 5	186155	Terminal 9
183642	Codebar 9	184336	Keytop 5	186253	Lever w/Hub 2,3
183643	Codebar 9	184337	Keytop 5	186314	Spring 2,8
183644	Codebar 9	184338	Keytop 5	186339	Spring 8
183645	Codebar 9	184339	Keytop 5	186343	Codebar 7,8,9
183646	Codebar 9	184340	Keytop 5	186346	Shield, Magnetic 11
183647	Codebar 7	184341	Keytop 5	186349	Bracket 11
183648	Codebar 7	184342	Keytop 5	186406	Lever, Reset 11
183649	Codebar 7	184343	Keytop 5	186408	Modification Kit 11
183876	Screw, 6-32 Set 11	184344	Keytop 5	186417	Wire, Contact 8
183888	Keytop 5	184345	Keytop 5	186419	Lever 8
183889	Keytop 5	184346	Keytop 5	186435	Spring 2
183890	Keytop 5	184351	Keytop 5	186436	Spring 10
183891	Keytop 5	184734	Keytop 5	186437	Spring 7,8,9
183892	Keytop 5	184815	Keytop 5	186700	Shaft 3
183951	Wire, Contact 2,8	184816	Keytop 5	186701	Plate 3
184021	Cover, Keyboard 4	184817	Keytop 5	186702	Screw, 6-32 Spl 3
184022	Keylever 6	184818	Keytop 5	186703	Plate, Top Mounting 3
184023	Keylever 6	184869	Keytop 5	186704	Stud 3
184024	Keylever 6	184895	Keytop 5	186705	Shaft 3
184025	Keytop 5	185089	Keytop 5	186706	Cam, Trip 3
184026	Keytop 5	185090	Keytop 5	186707	Lever 3
184027	Keytop 5	185092	Keytop 5	186709	Bushing, Eccentric 3
184031	Terminal 9	185093	Keytop 5	186746	Lever 6
184032	Insulator, .031" Thk 9	185150	Keytop 5	186752	Modification Kit 1,3
184033	Spacer, .035" Thk 9	185159	Keytop 5	186754	Bushing 3
184106	Block Assembly, Right Contact 9	185160	Keytop 5	192191	Knob 12
184107	Block Assembly, Right Contact 2	185161	Keytop 5	192538	Plug, Button 4
184108	Block Assembly, Right Contact 10	185162	Keytop 5	195307	Keylever, Repeat 6
184109	Block Assembly, Right Contact 8,11	185163	Keytop 5	195309	Lever, Non-Repeat 7
184111	Block Assembly, Right Contact 9	185164	Keytop 5	195312	Lever, Reset 10
184135	Block Assembly, Left Contact 8	185165	Keytop 5	195315	Solenoid w/Plunger 10
184165	Lever, Reset 11	185394	Keytop 5	195317	Pin 10
184174	Switch, SP-DT 11	185395	Keytop 5	195321	Bracket, Switch 10
		185396	Keytop 5	195322	Switch 10
		185619	Frame, Left Keyboard 2	195332	Bracket, Power Switch 12
		185620	Frame, Right Keyboard 2	195333	Switch, Pushbutton 12
		185780	Spring, Compression 6	195465	Plate, Mounting 10
		185798	Spring 7,8,9	195470	Insulator, .031" Thk 10
		185801	Modification Kit 1,3		

NUMERICAL INDEX (Continued)

Part Number	Description and Page Number	Part Number	Description and Page Number	Part Number	Description and Page Number
195471	Wire, Contact 10	195483	Plate 10,12	305537	Plug, Button 4
195472	Terminal 10	195563	Lens, Red Pushbutton 12	305706	Shaft w/Link 10
195473	Terminal, Common 10	195568	Lamp, 6 V 12	305707	Arm, Reset 10
195474**	Panel, Top 12	195965	Tray, Copyholder 12	305708	Bracket, Solenoid 10
195475	Cover, Keyboard 4,12	198670	Screw w/Lockwasher, 6-40 x 5/16 Hex 12	311516	Post 12
195481**	Cover	303037	Spring, Compression 3	312918	Strap 10
195482	Cable Assembly 10			321895	Post 3
				333588	Lamp, 28V Miniature 12

33 TYPING UNIT (UP)

PARTS

FIGURE	CONTENTS	PAGE	FIGURE	CONTENTS	PAGE
1	Platen Mechanism-Friction Feed	2	24	Line Feed Function Lever Mechanism	23
2	Paper Handling Mechanism-Friction Feed	3	25	Function Levers	24
3	Platen Mechanism-Sprocket Feed	4	26	Function Levers (Continued)	25
4	Platen Mechanism-Sprocket Feed (Continued)	5	27	185971 Modification Kit to Provide Printer With an End-of-Line Bell to Ring on Approximately the 62nd Character	26
5	Ribbon Feed Mechanism	6	28	185991 Modification Kit to Provide Controlled Single or Double Line Feed Feature on Friction Feed Printer	26
6	Carriage Upper Plate Mechanism	7	29	Typewheel Chart	27
7	Carriage Lower Plate Mechanism	8	30	Typewheel Chart (Continued)	28
8	Carriage Power Bail Mechanism	9	31	Typewheel Chart (Continued)	29
9	Carriage Drive Bail Mechanism	10	32	Formout Mechanism-Sprocket Feed	30
10	Main Shaft Mechanism-Friction Feed	11	33	Later Design Formout Mechanism- Sprocket Feed	31
11	Main Shaft Mechanism-Sprocket Feed	12	34	Motor Contact-Sprocket Feed	31
12	182015 Clutch Trip Lever Assembly	13	35	Solenoid Print-Nonprint Reset Mechanism	32
13	Code Bar Basket Mechanism	14	36	Base	33
14	Function Box Mechanism	15	37	Sub Bases	34
15	Function Shaft Mechanism	16	38	Motors	35
16	Selector Frame Mechanism	17	39	Electrical Components	36
17	Clutch and Camsleeve Mechanism	18	40	Cable Components	37
18	Distributor Clutch Mechanism	19		Numerical Index	38
19	Trip Shaft Mechanism	20			
20	182964 Drive Arm Assembly	21			
21	Clutch Trip Mechanism	21			
22	Answer-Back Drum Mechanism	22			
23	Answer-Back Trip Magnet Mechanism	22			

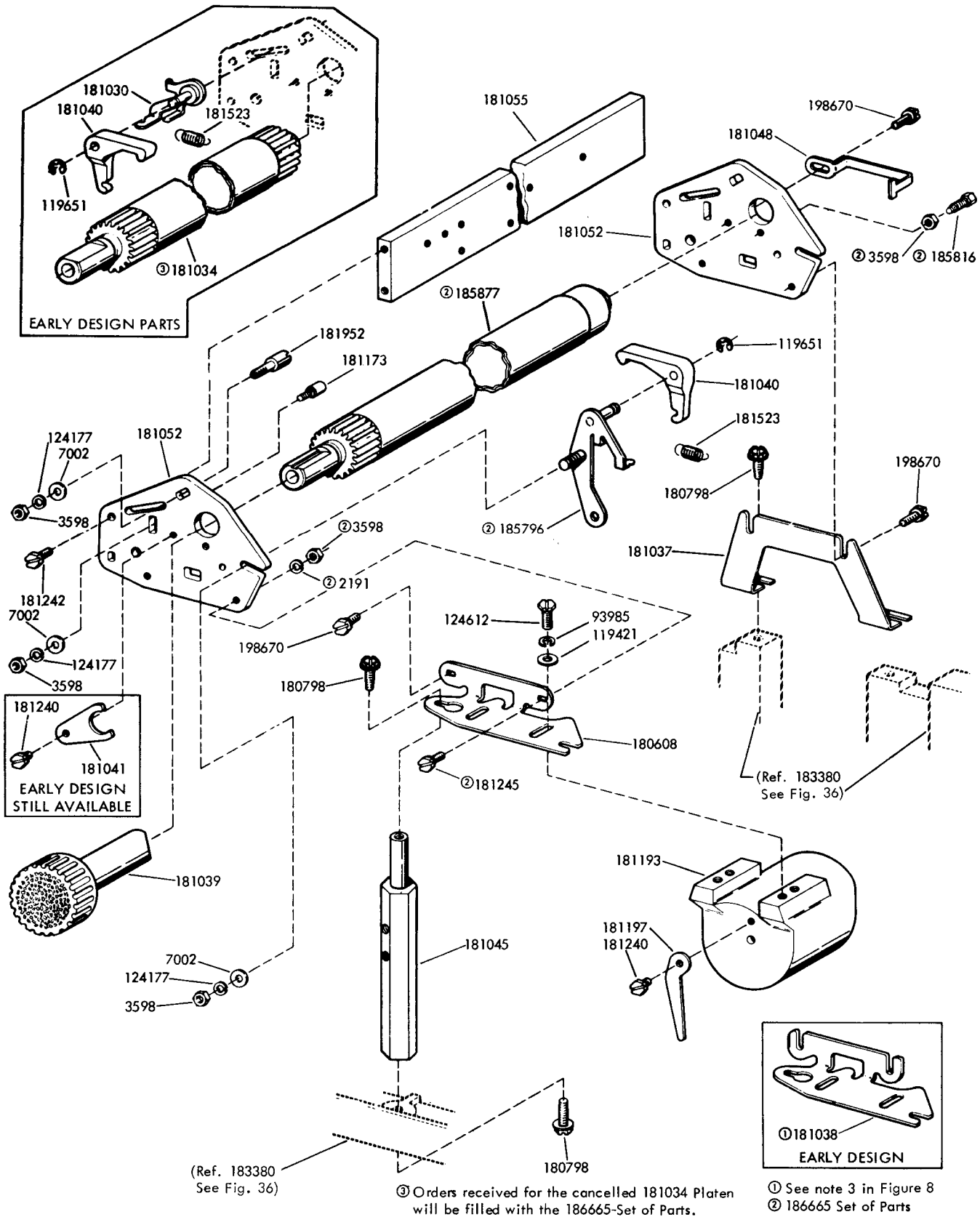

FIGURE 1. PLATEN MECHANISM - FRICTION FEED

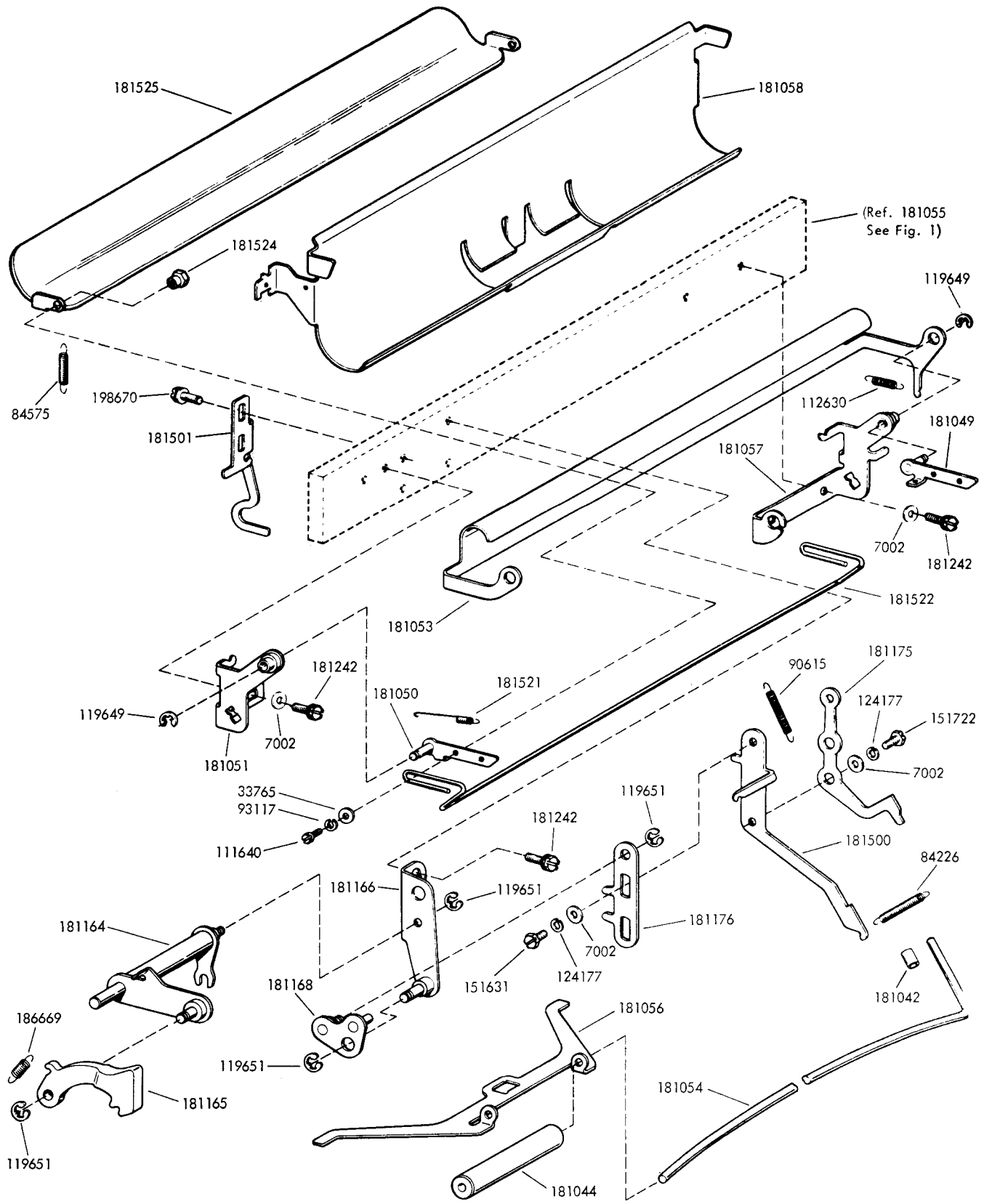

FIGURE 2. PAPER HANDLING MECHANISM - FRICTION FEED

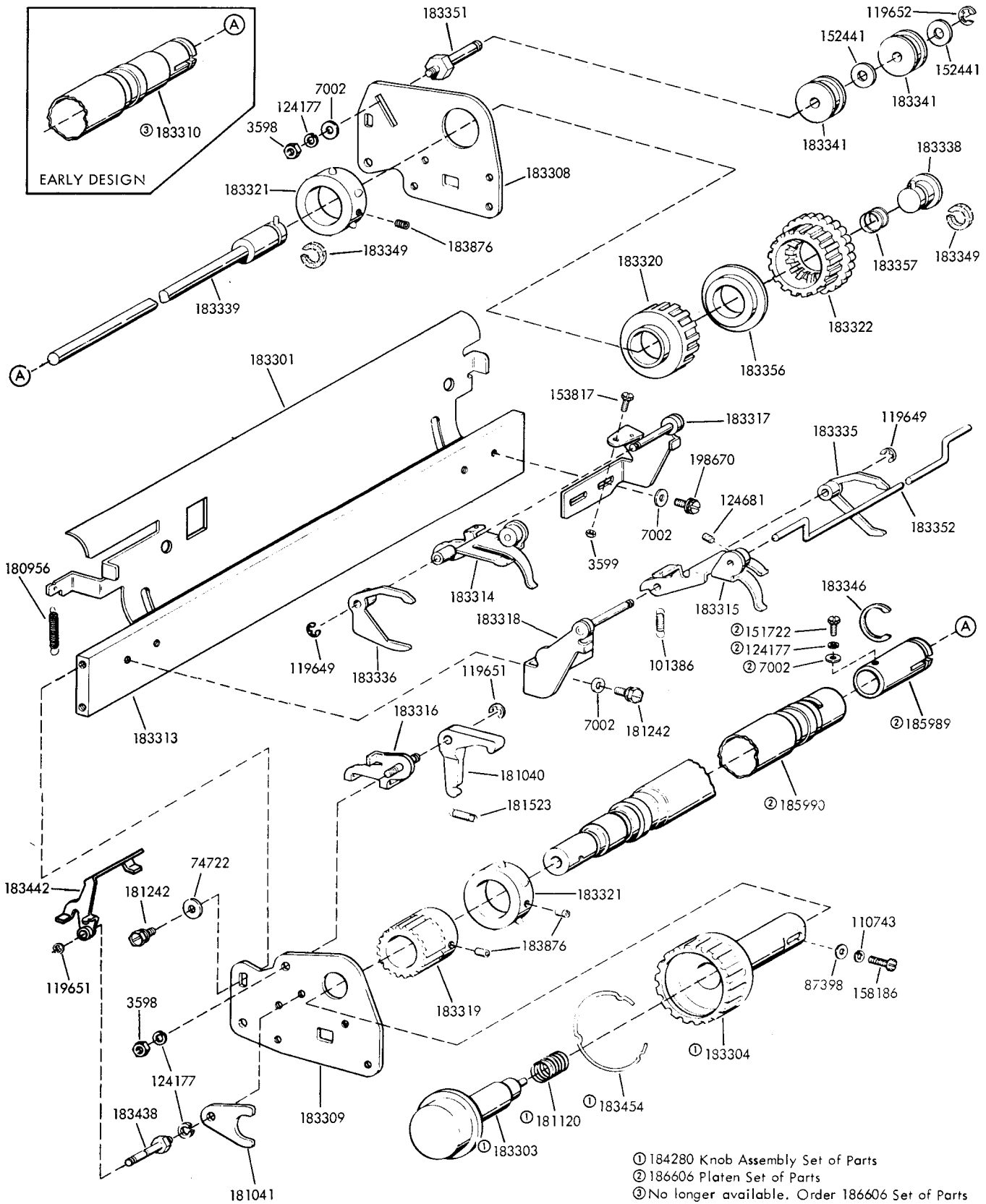

FIGURE 3. PLATEN MECHANISM - SPROCKET FEED

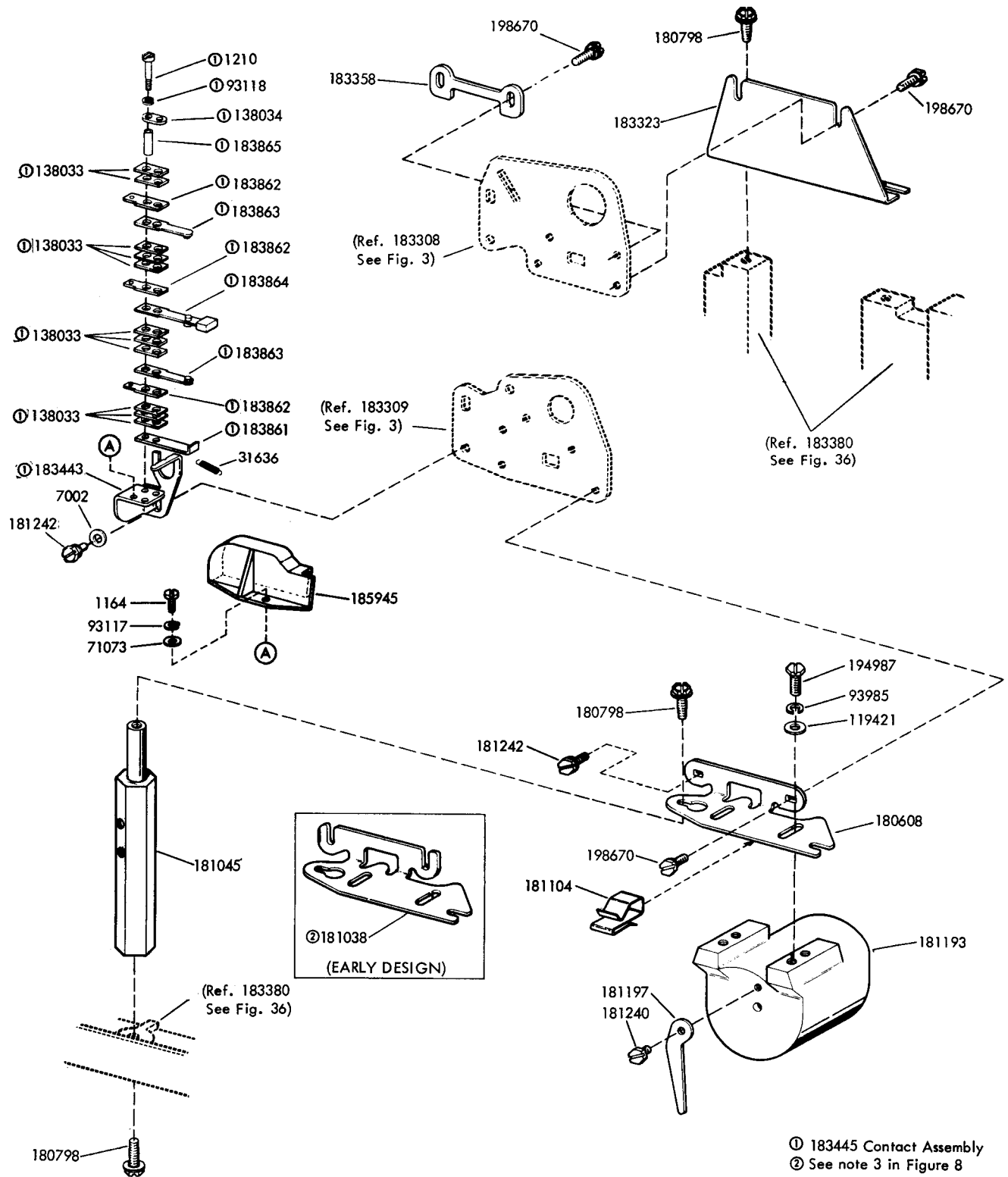

FIGURE 4. PLATEN MECHANISM - SPROCKET FEED (CONTINUED)

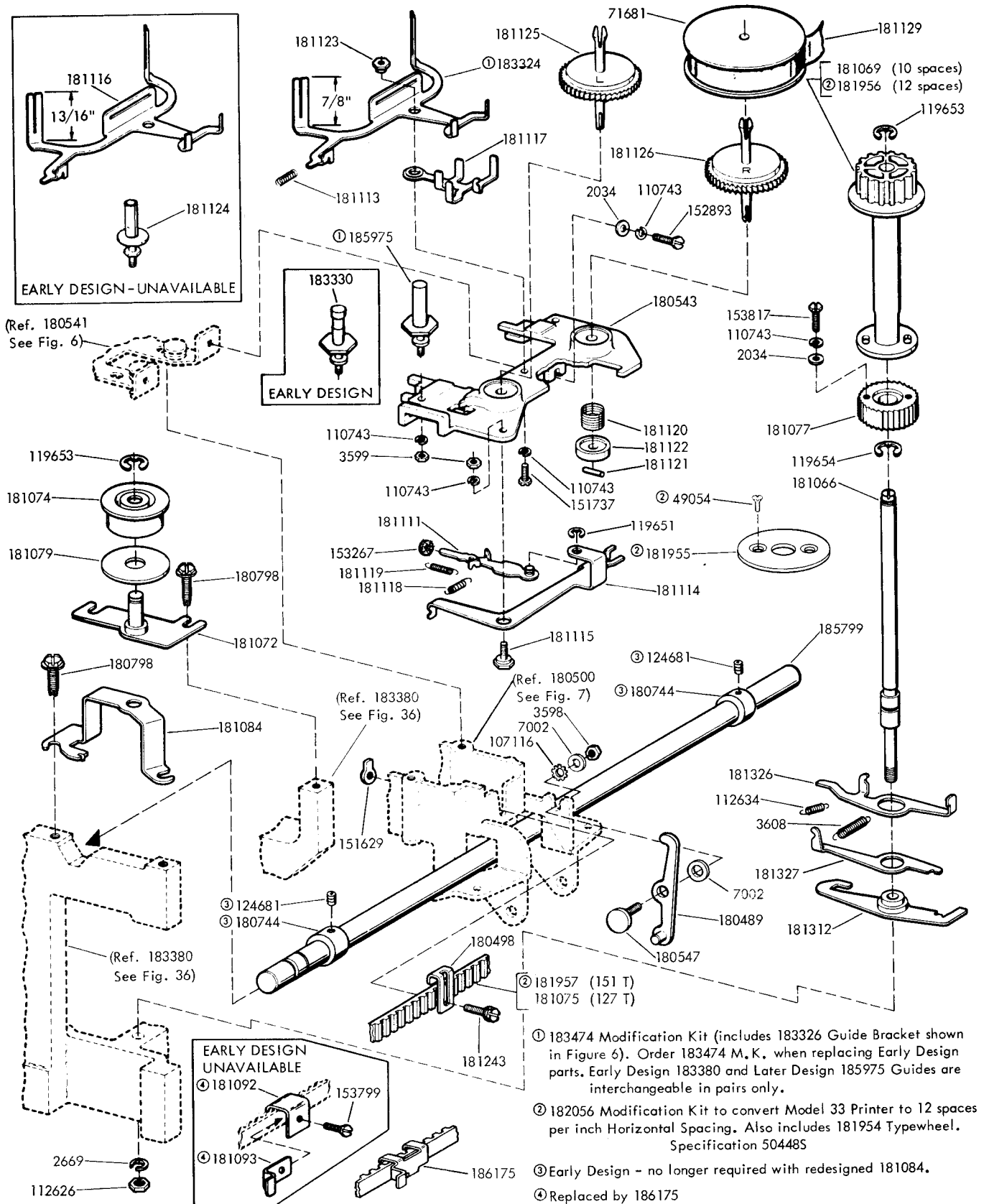

FIGURE 5. RIBBON FEED MECHANISM

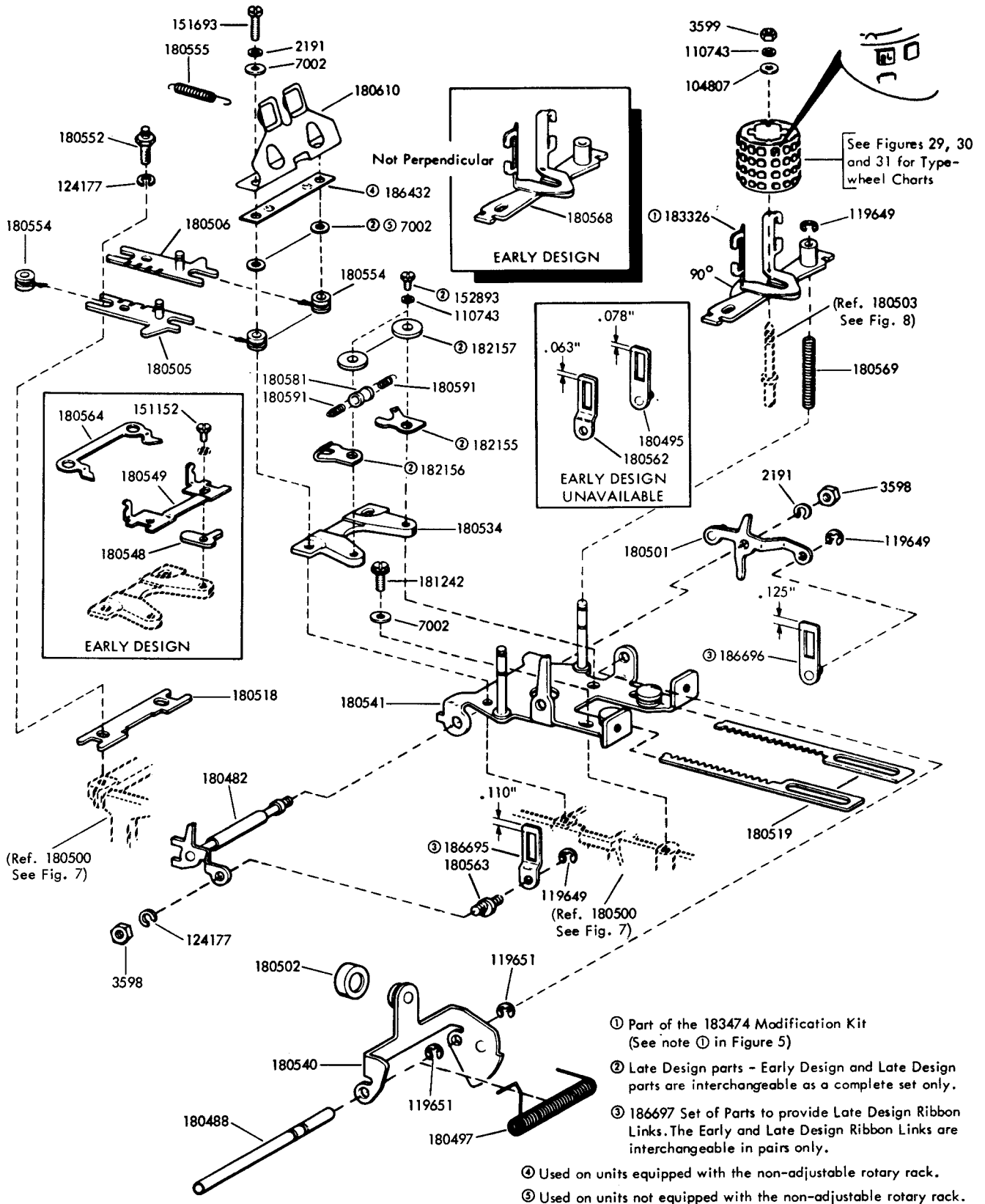

FIGURE 6. CARRIAGE UPPER PLATE MECHANISM

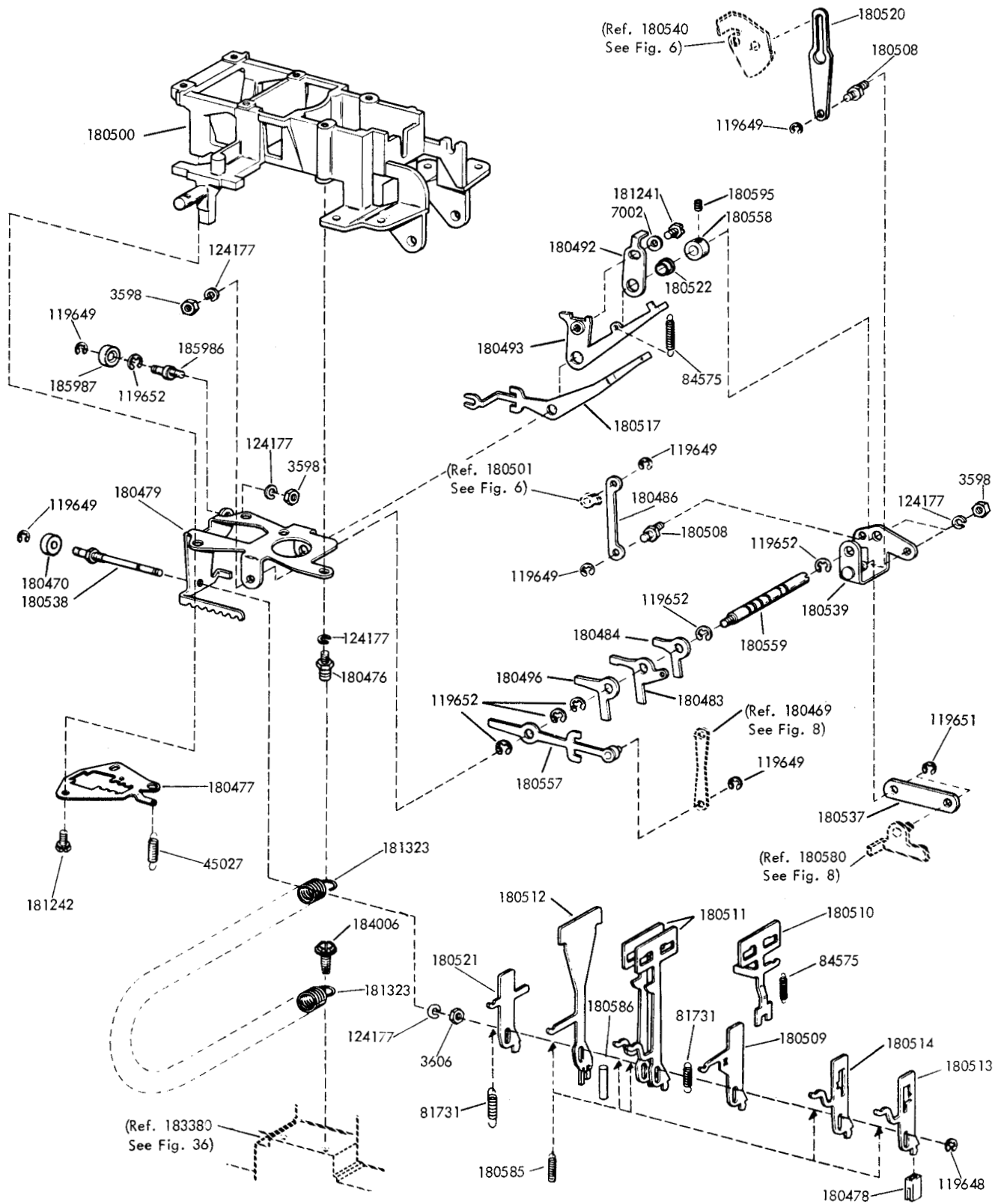

FIGURE 7. CARRIAGE LOWER PLATE MECHANISM

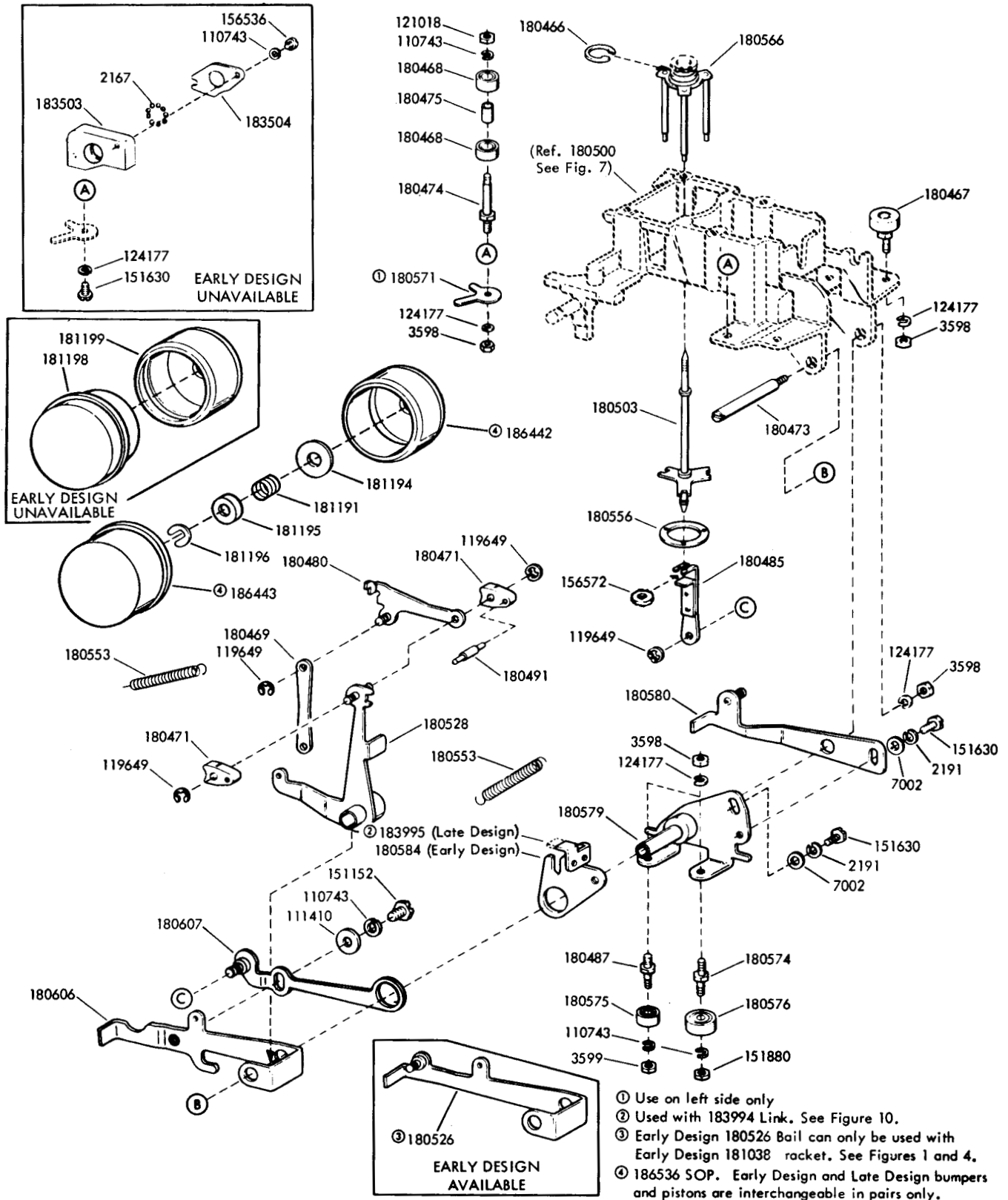

FIGURE 8. CARRIAGE POWER BAIL MECHANISM

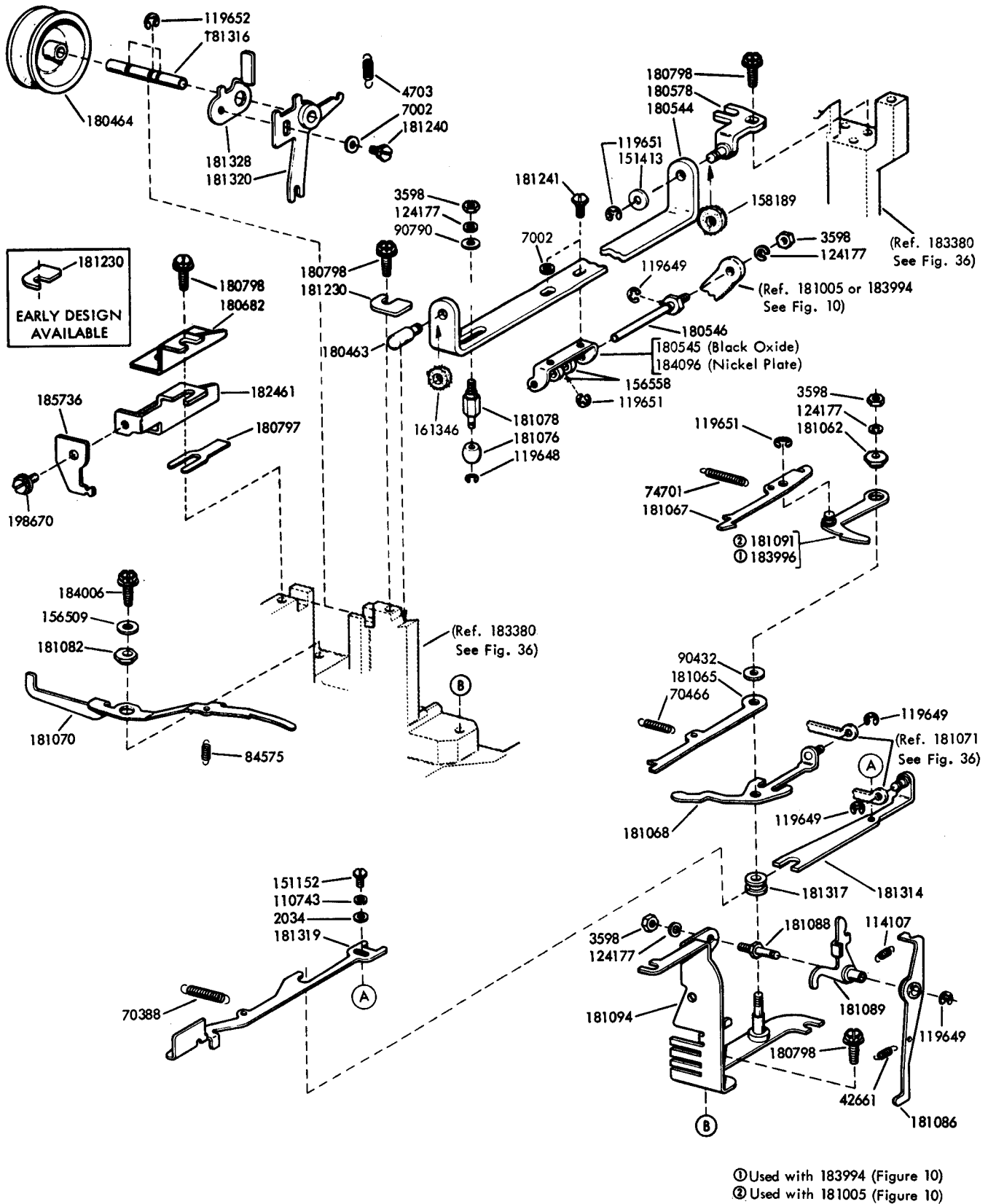

FIGURE 9. CARRIAGE DRIVE BAIL MECHANISM

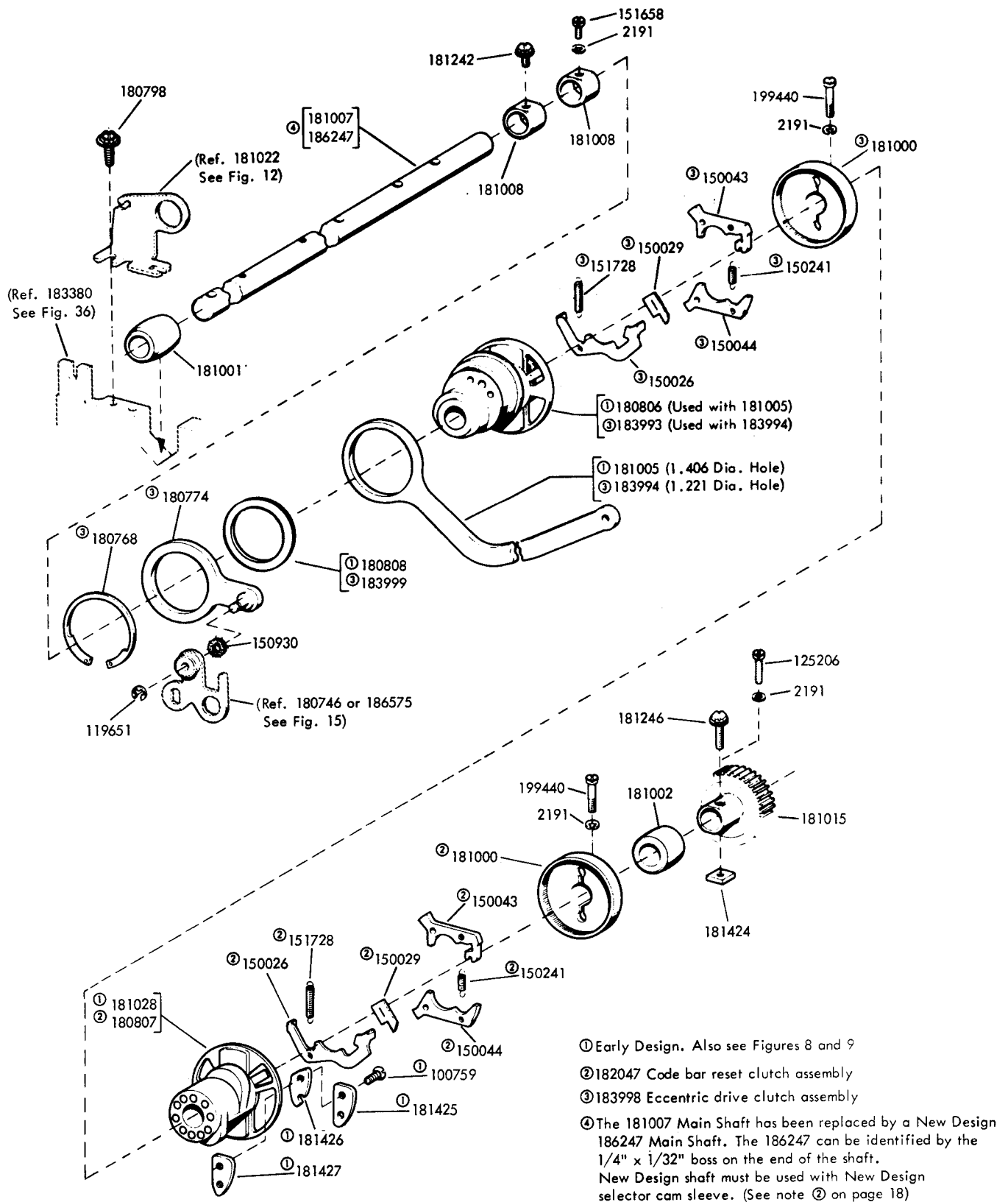

FIGURE 10. MAIN SHAFT MECHANISM - FRICTION FEED

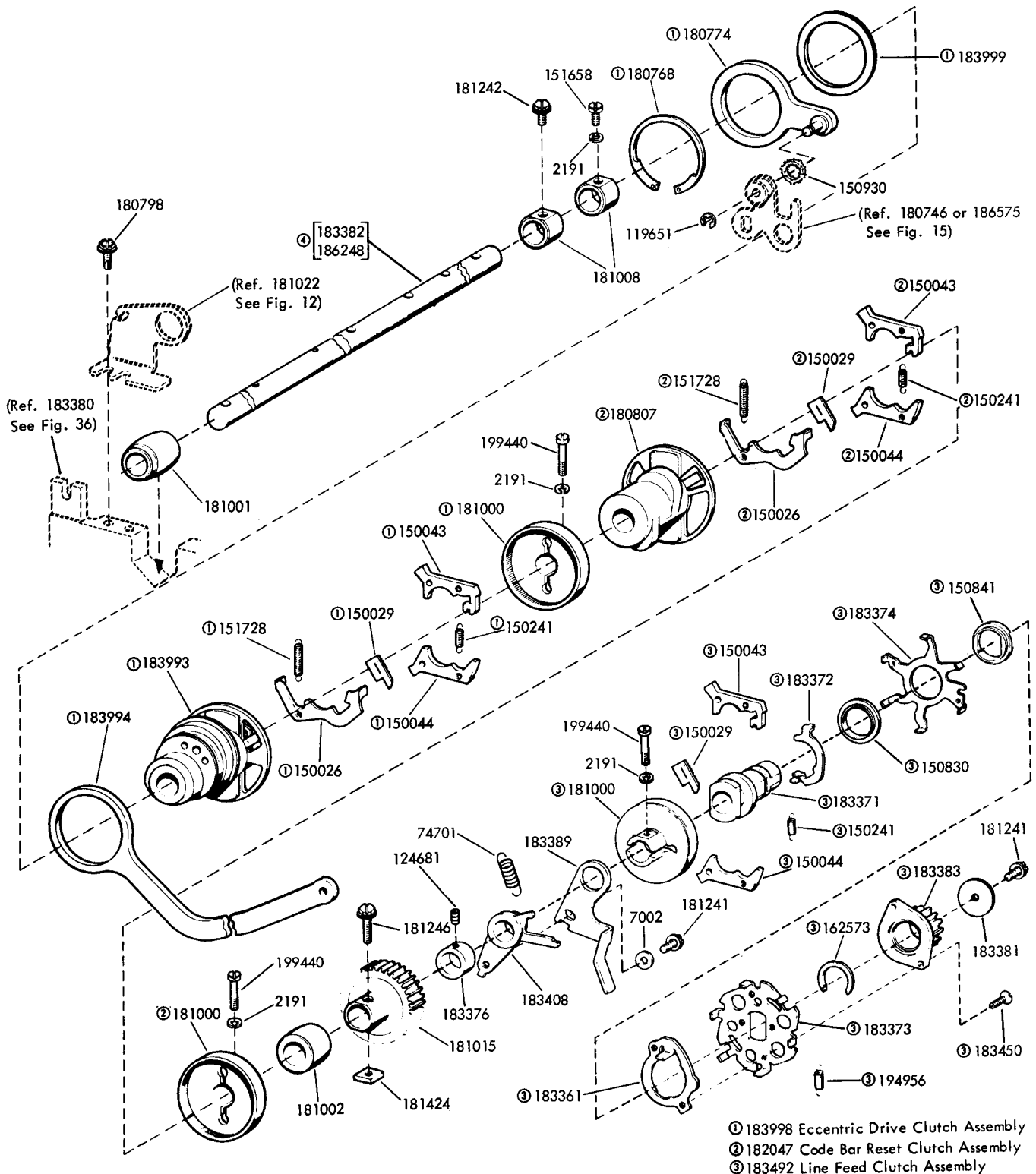

FIGURE 11. MAIN SHAFT MECHANISM - SPROCKET FEED

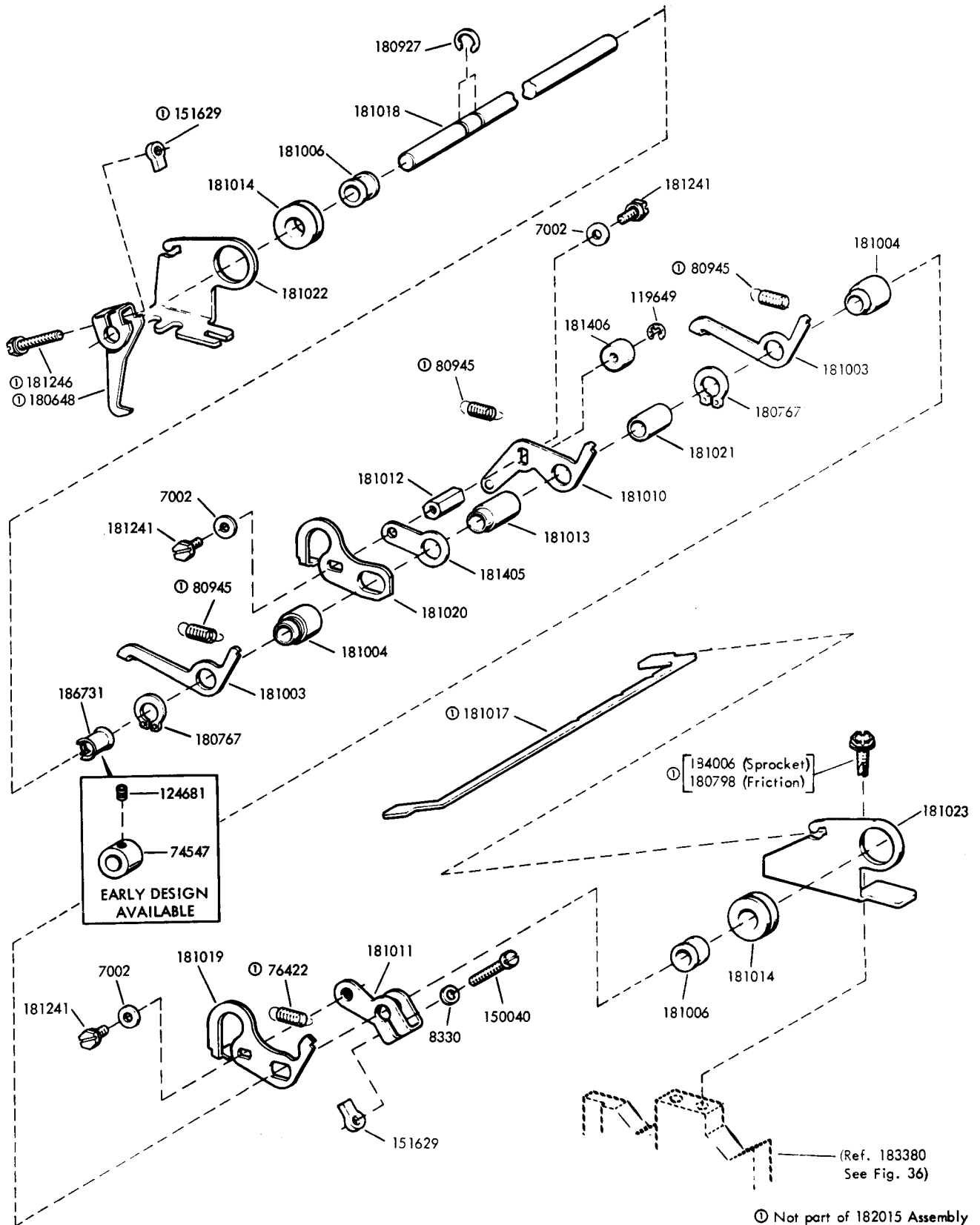

FIGURE 12. 182015 CLUTCH TRIP LEVER ASSEMBLY

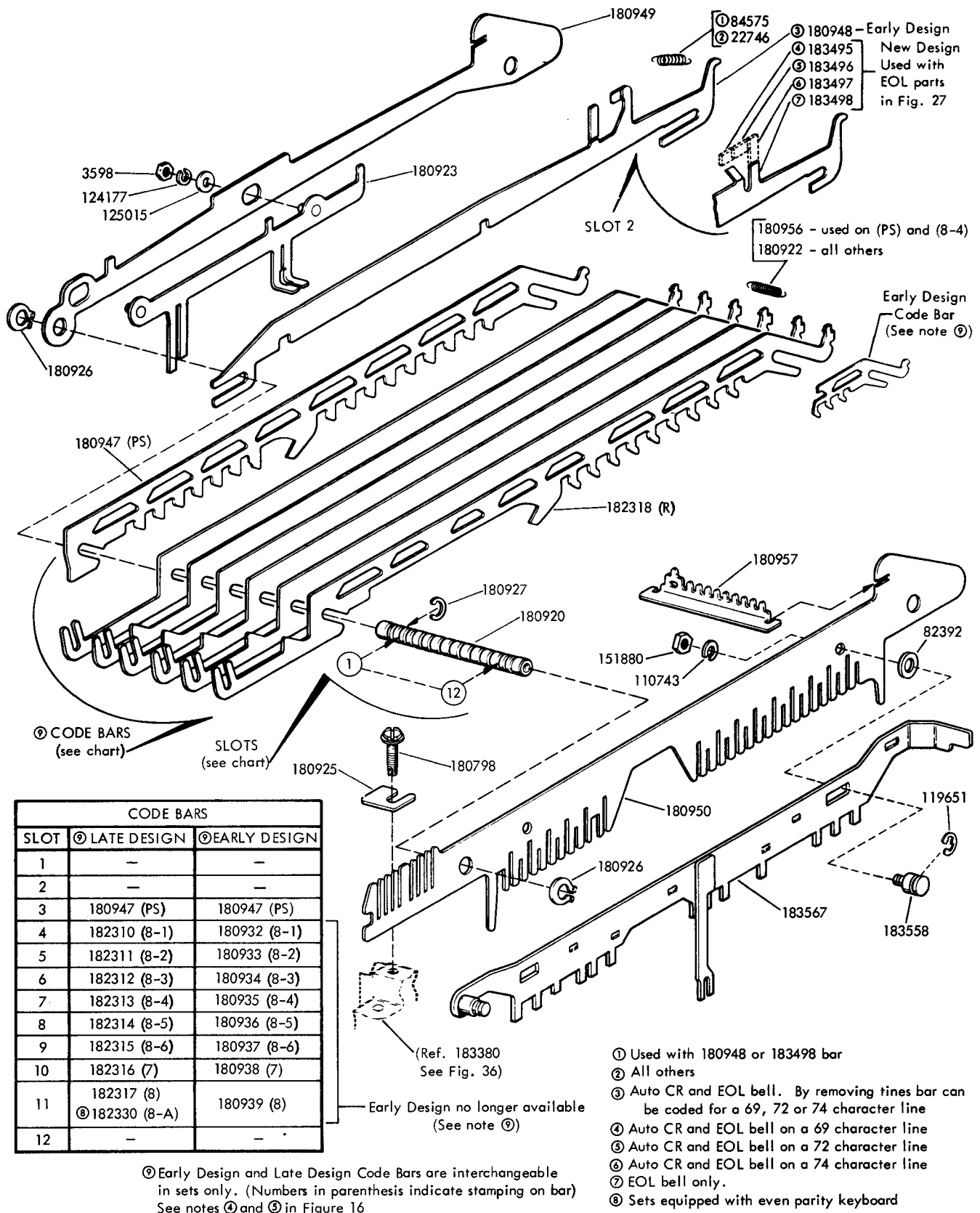

FIGURE 13. CODE BAR BASKET MECHANISM

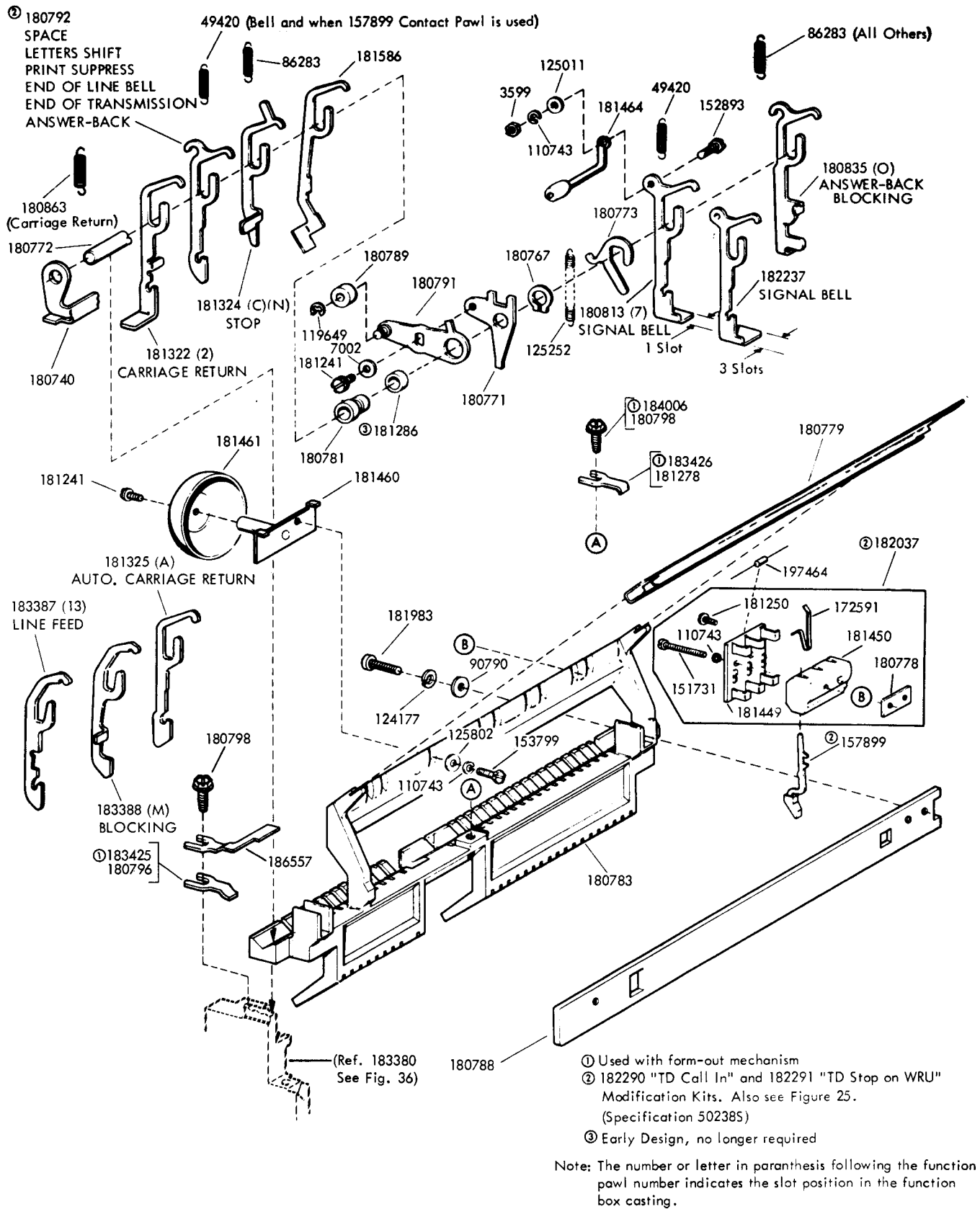

FIGURE 14. FUNCTION BOX MECHANISM

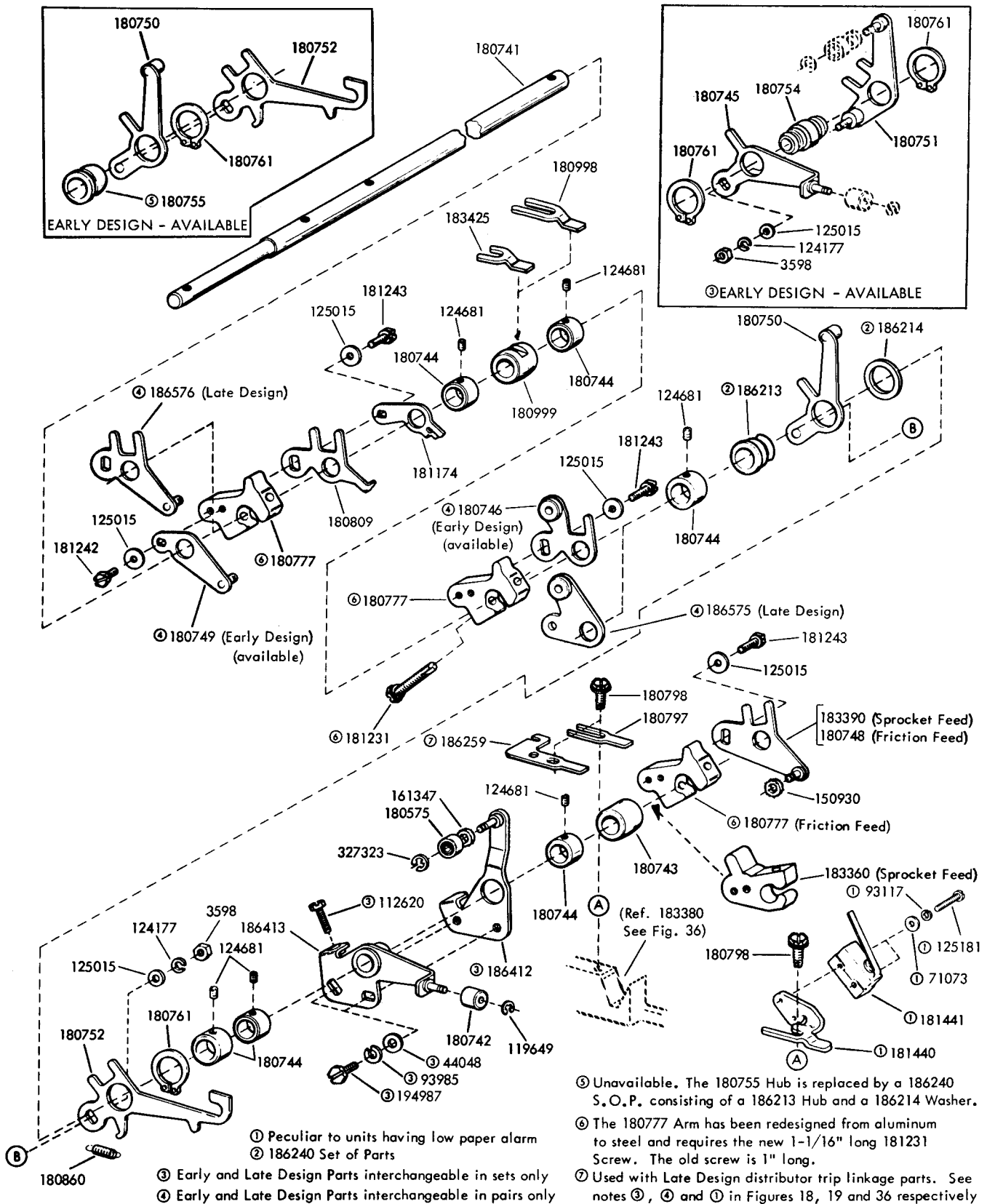

FIGURE 15. FUNCTION SHAFT MECHANISM

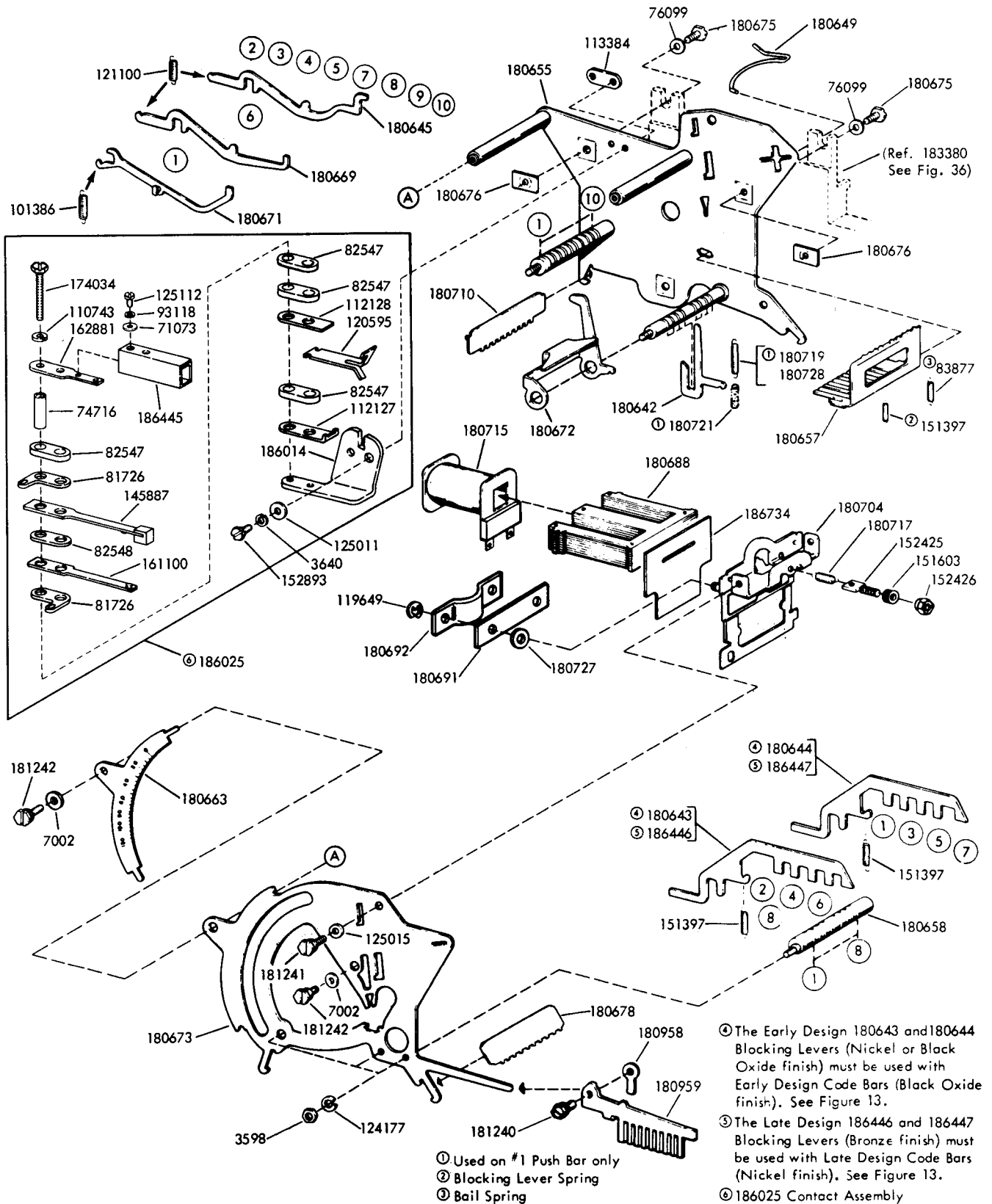

FIGURE 16. SELECTOR FRAME MECHANISM

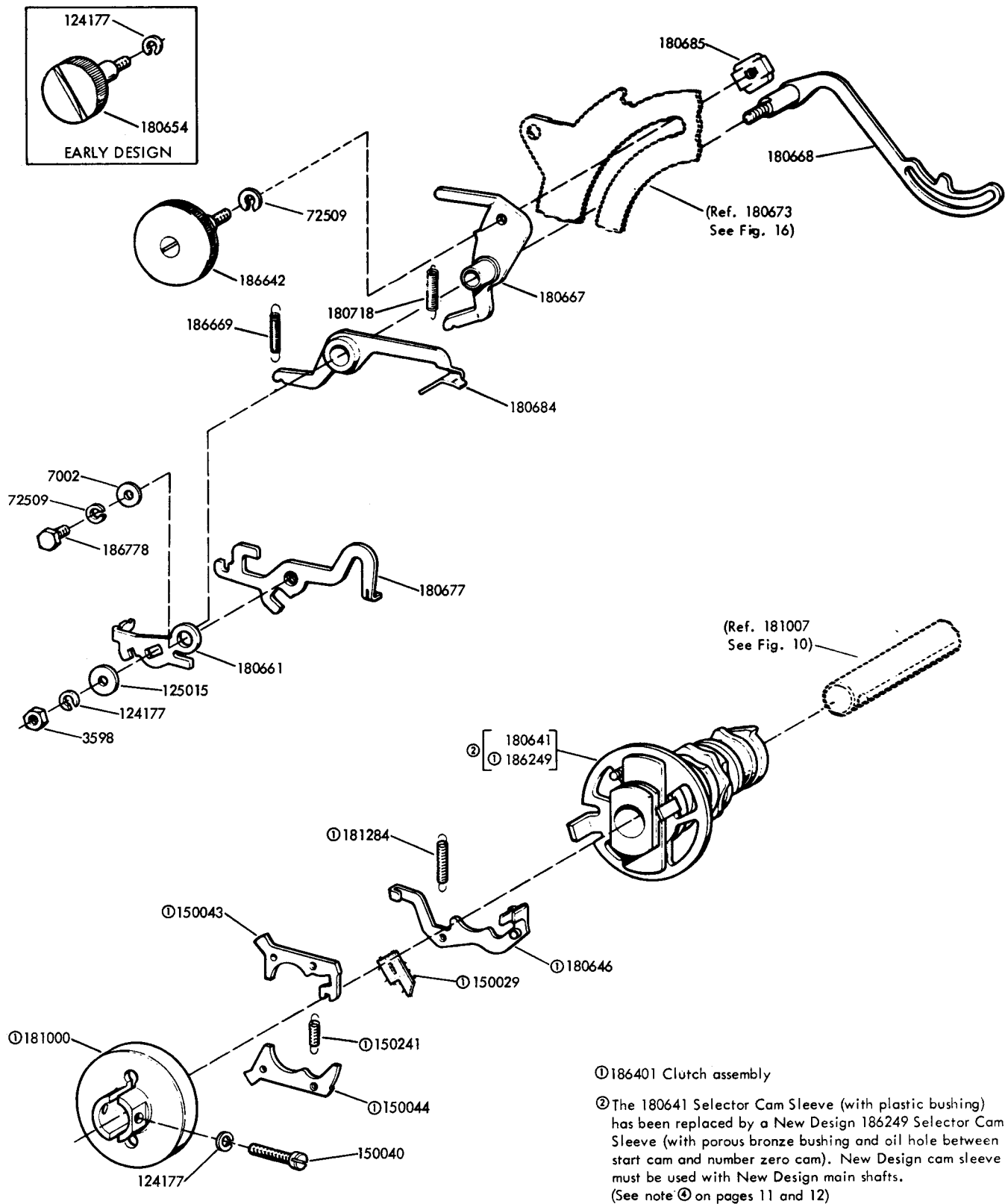

FIGURE 17. CLUTCH AND CAMSLEEVE MECHANISM

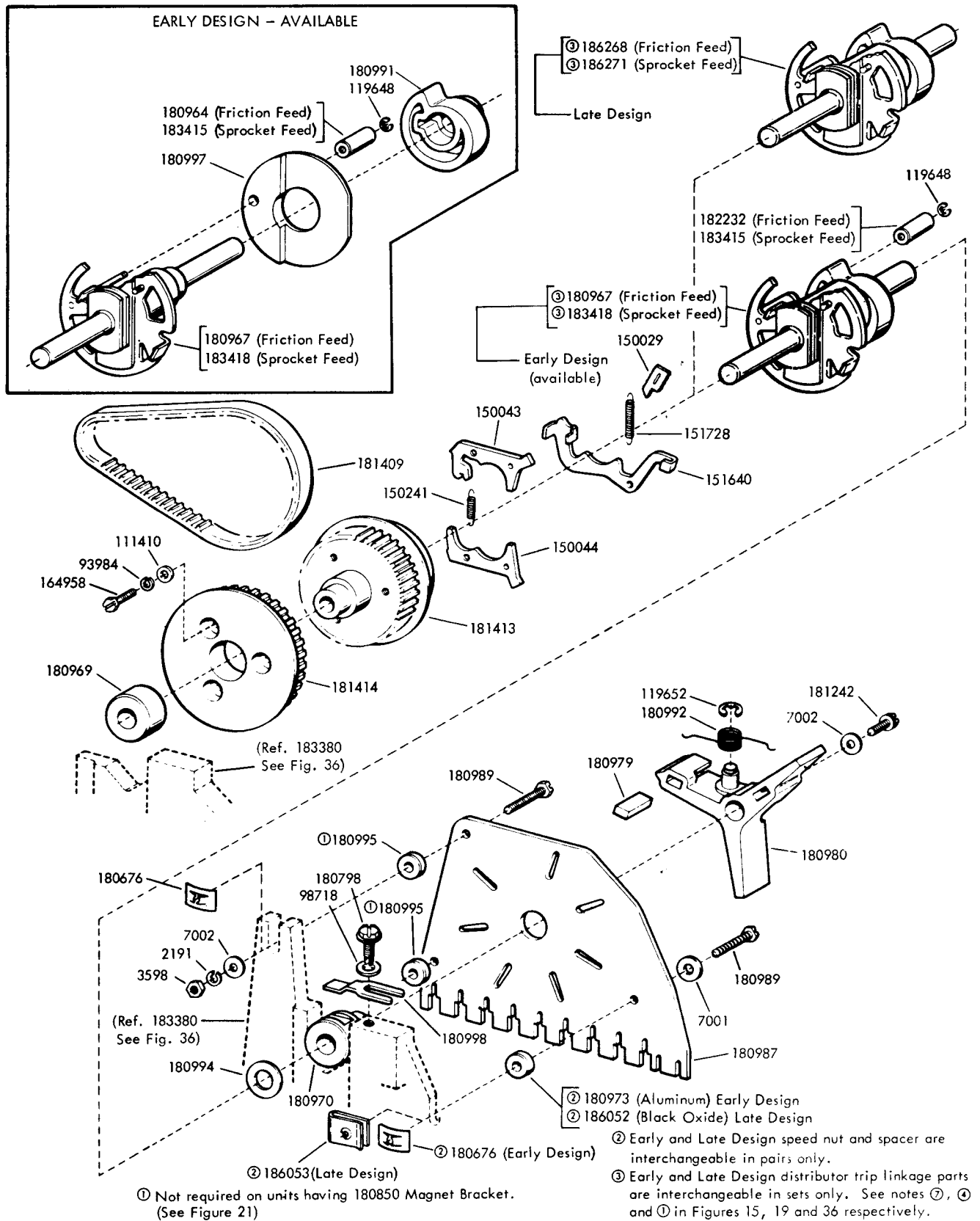

FIGURE 18. DISTRIBUTOR CLUTCH MECHANISM

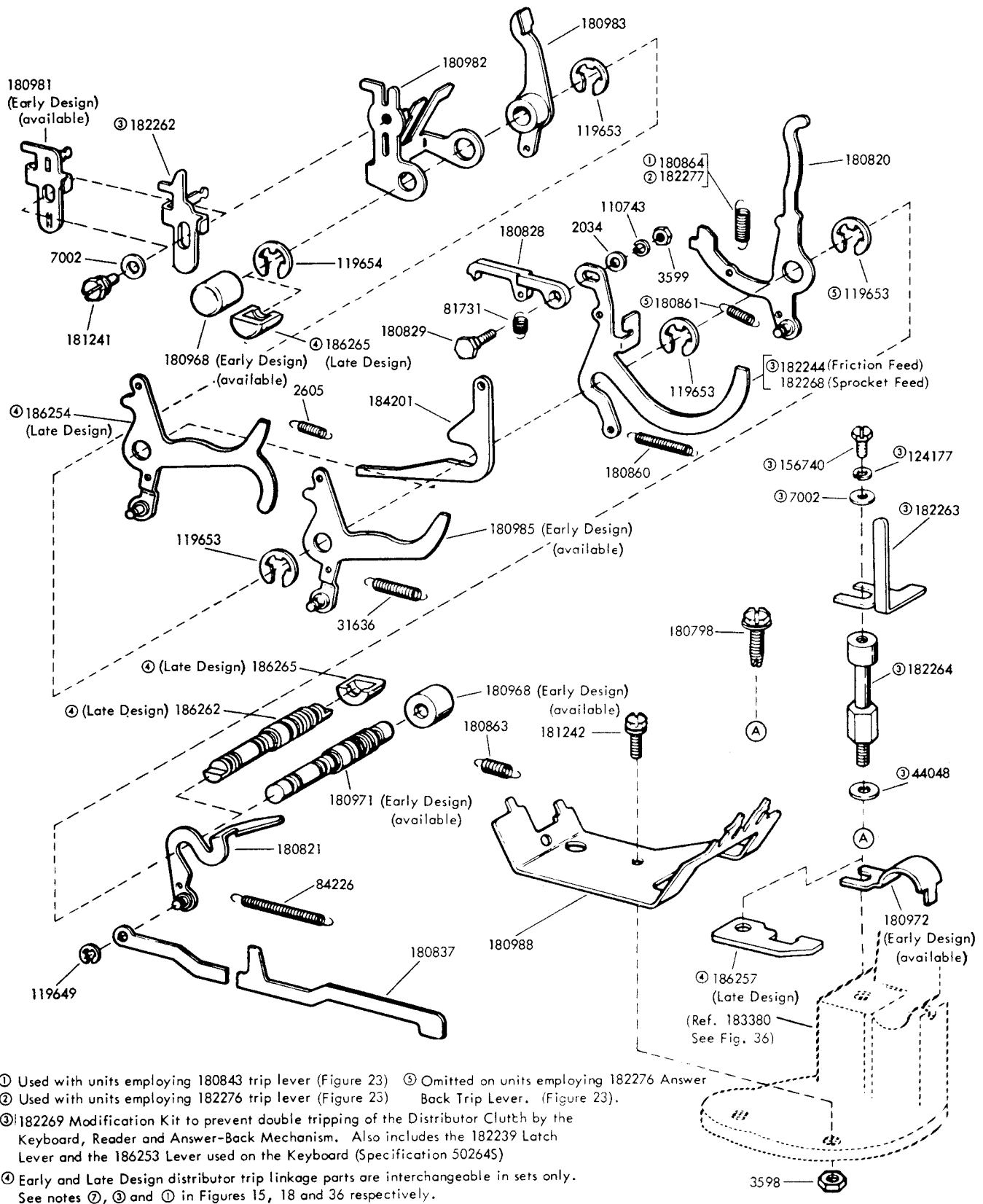

FIGURE 19. TRIP SHAFT MECHANISM

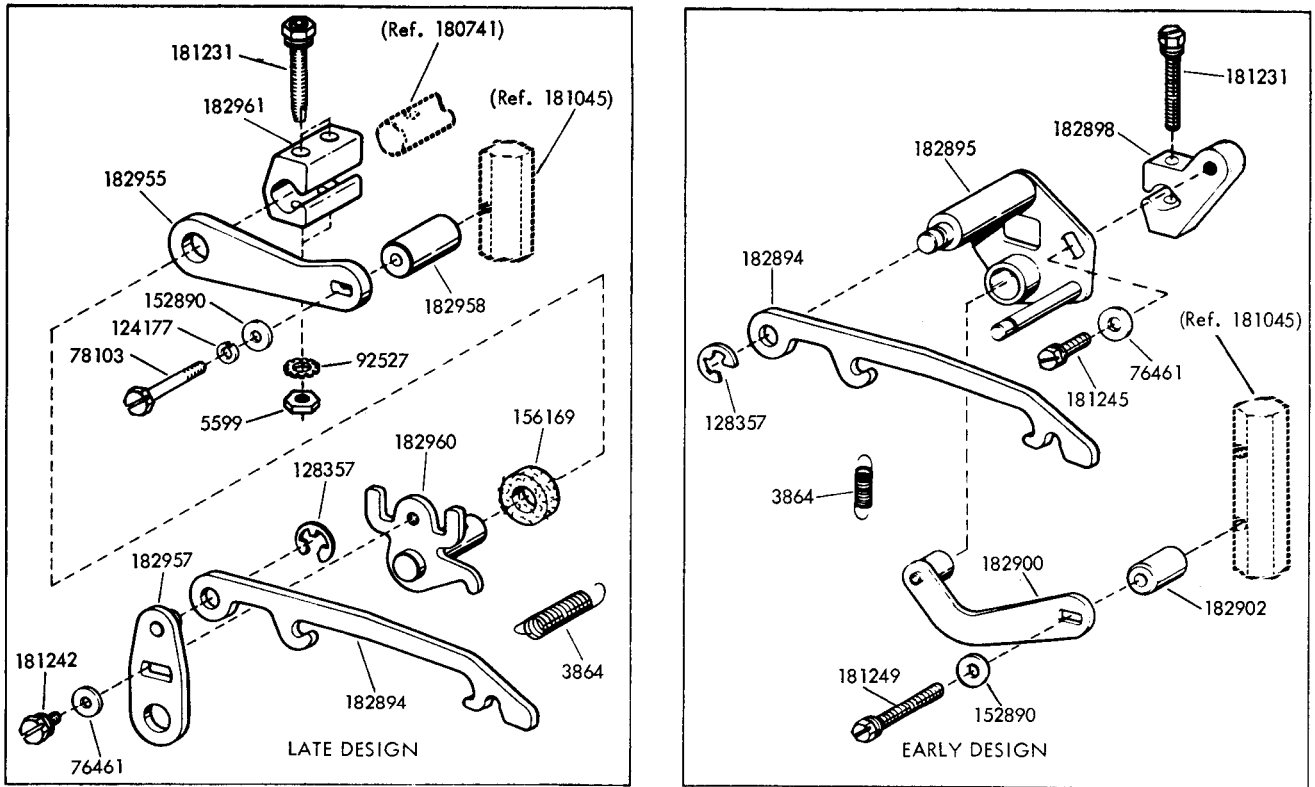

FIGURE 20. 182964 DRIVE ARM ASSEMBLY

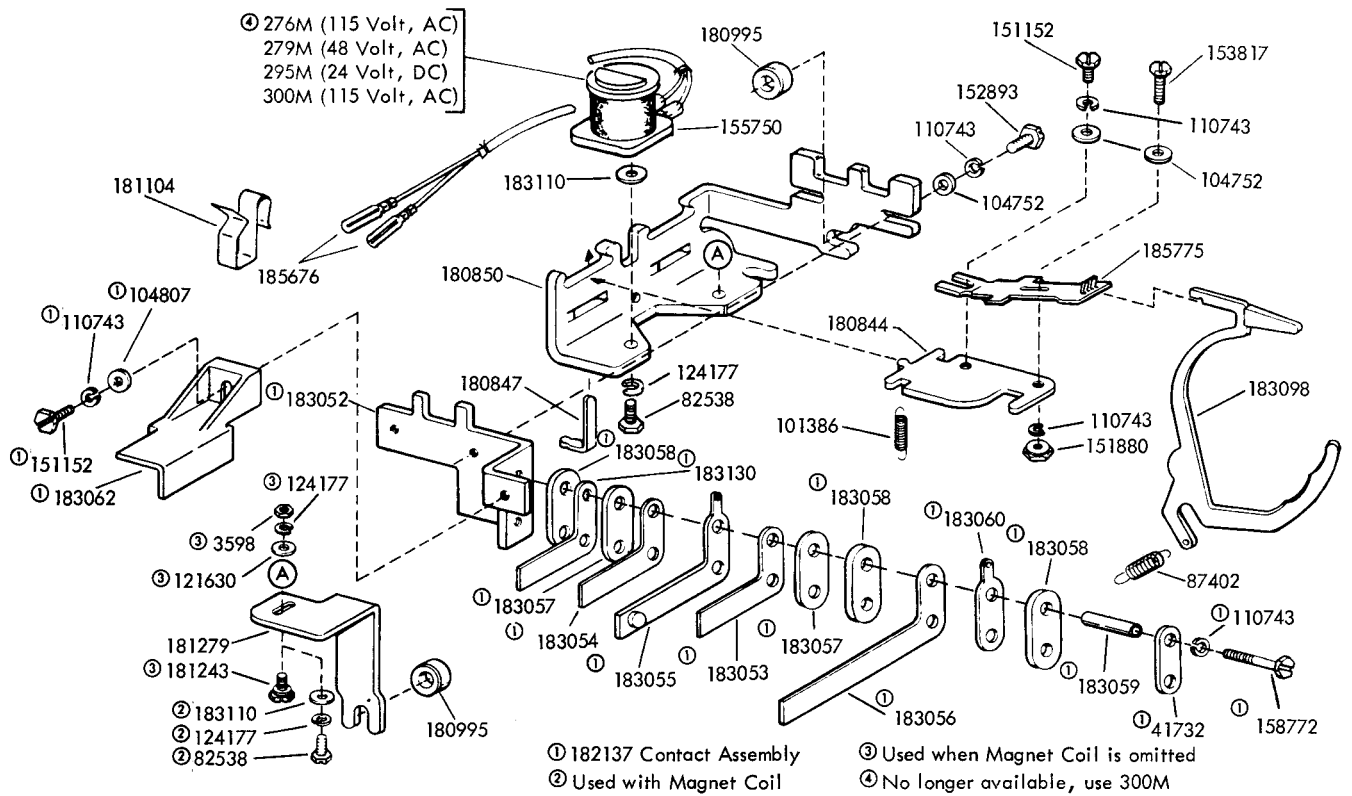

FIGURE 21. CLUTCH TRIP MECHANISM

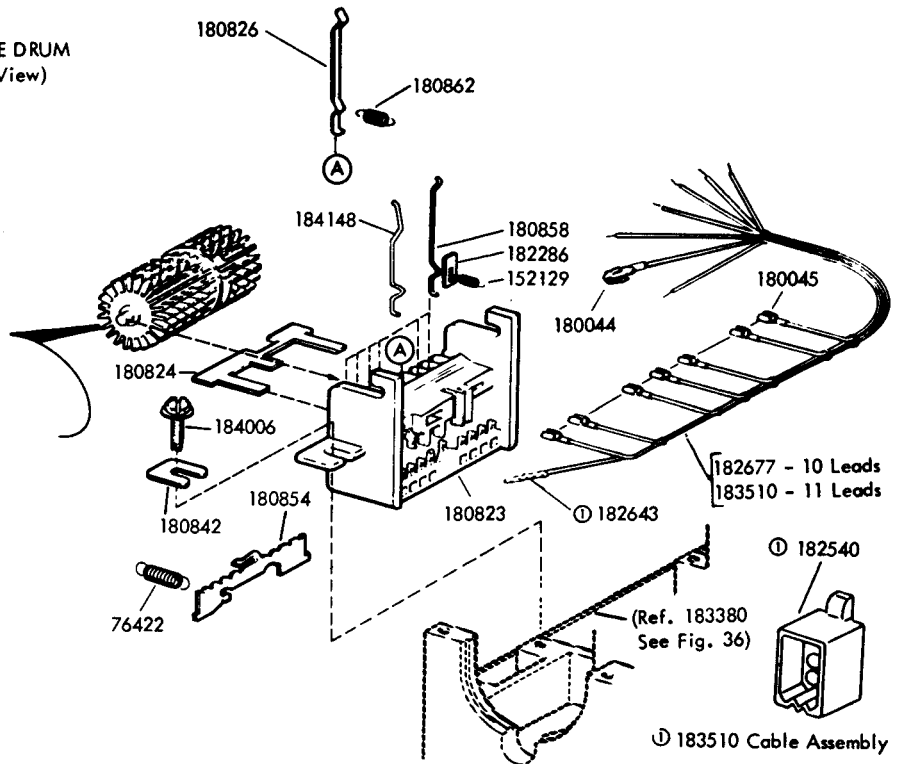
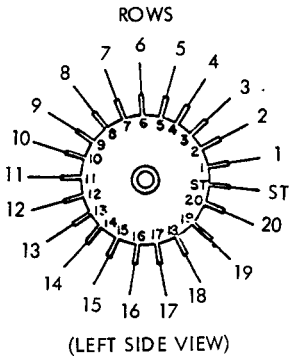
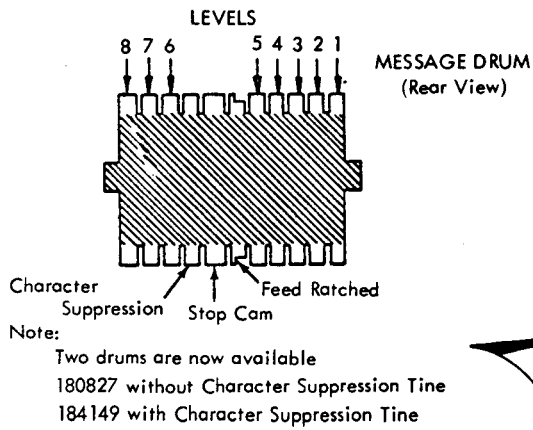

FIGURE 22. ANSWER-BACK DRUM MECHANISM

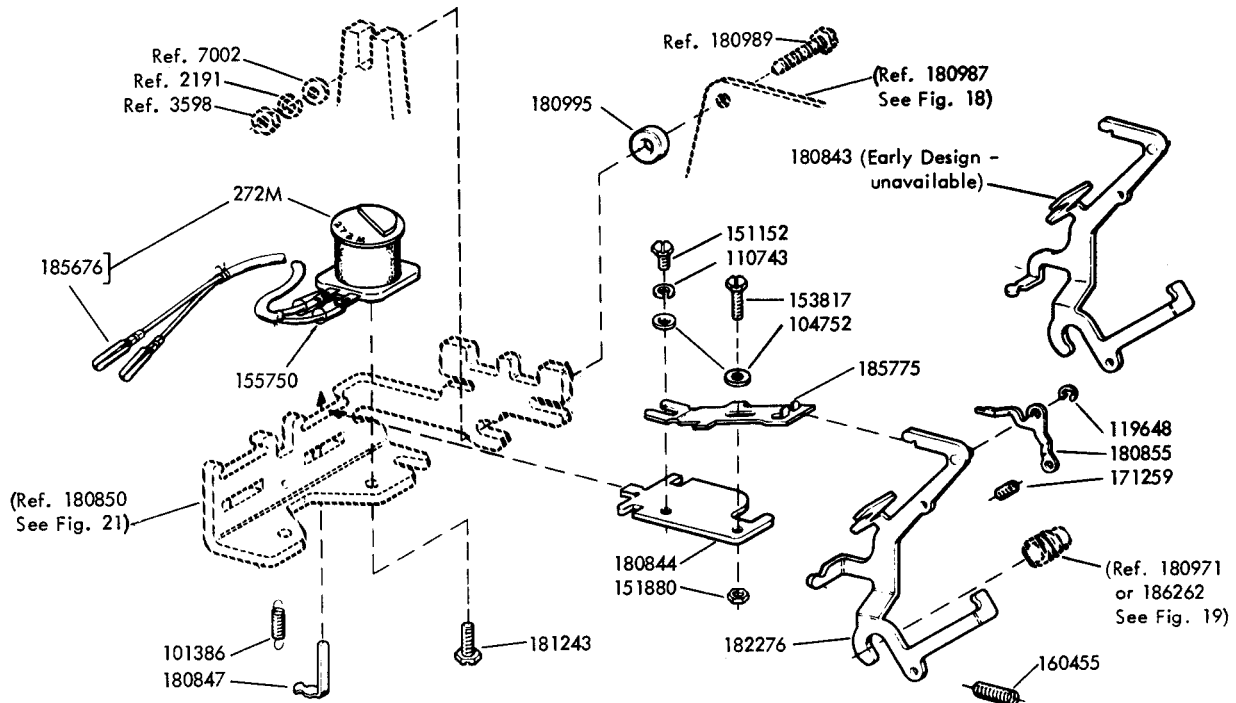

FIGURE 23. ANSWER-BACK TRIP MAGNET MECHANISM

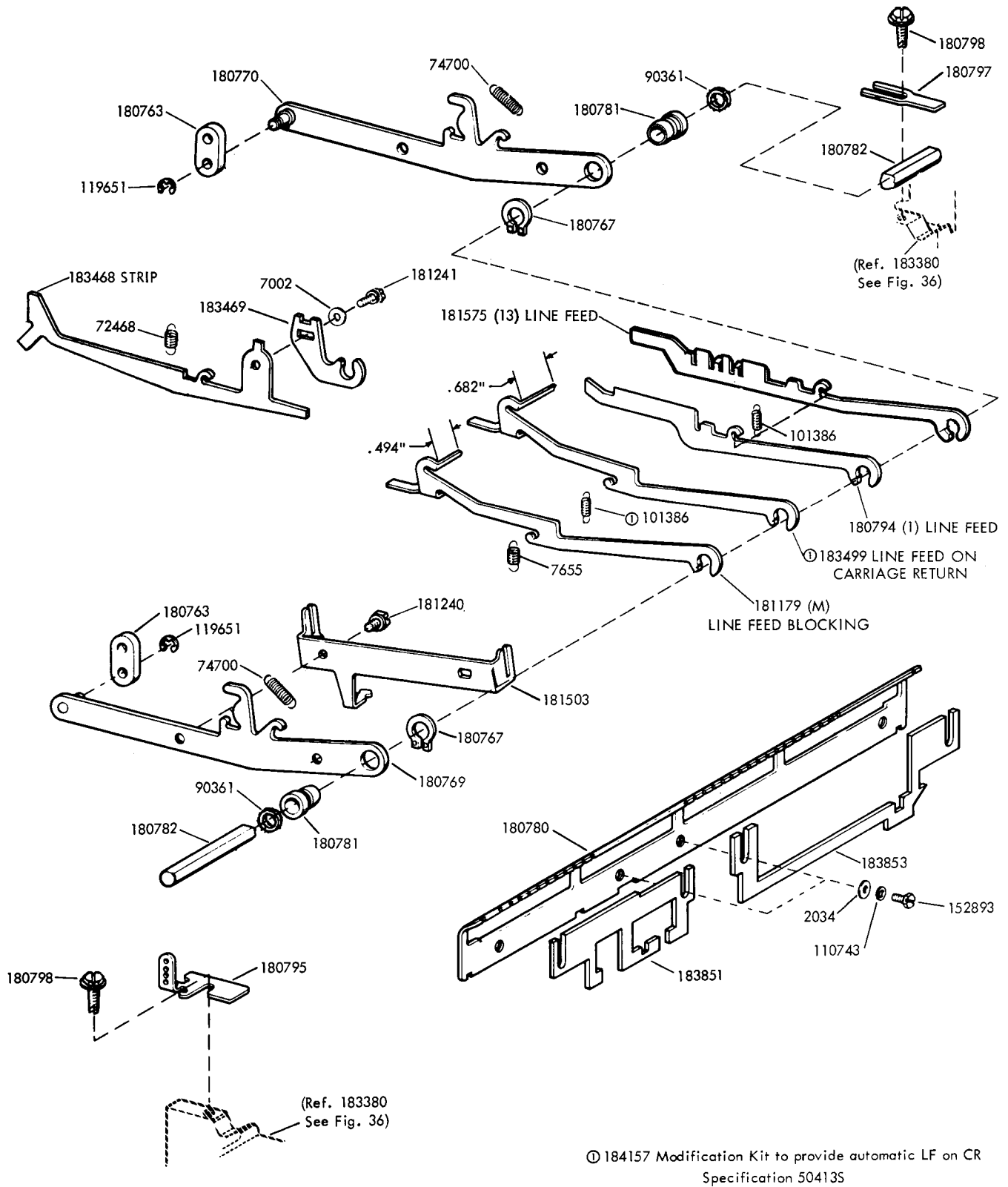
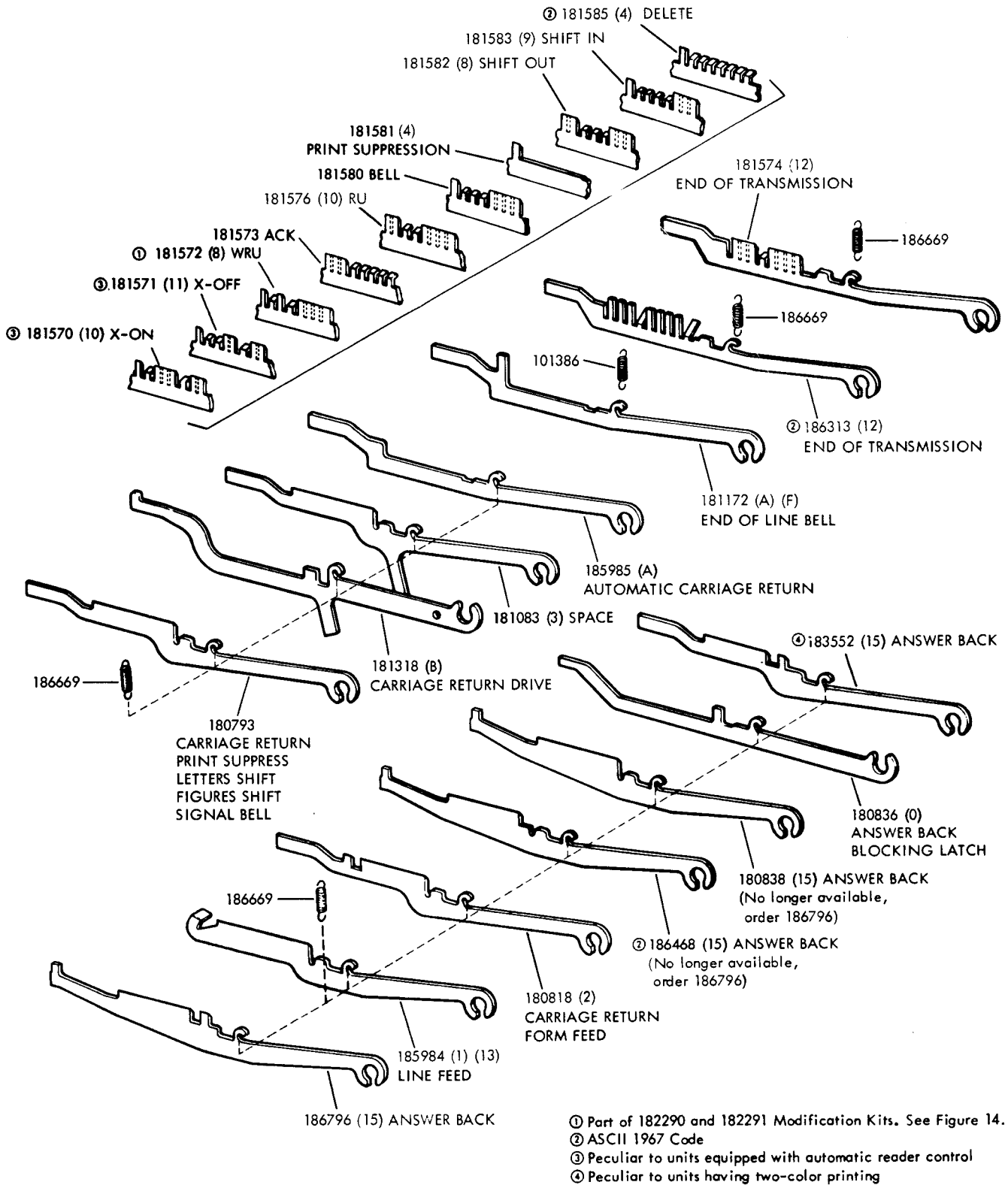
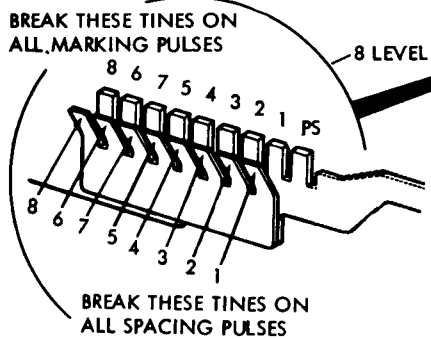
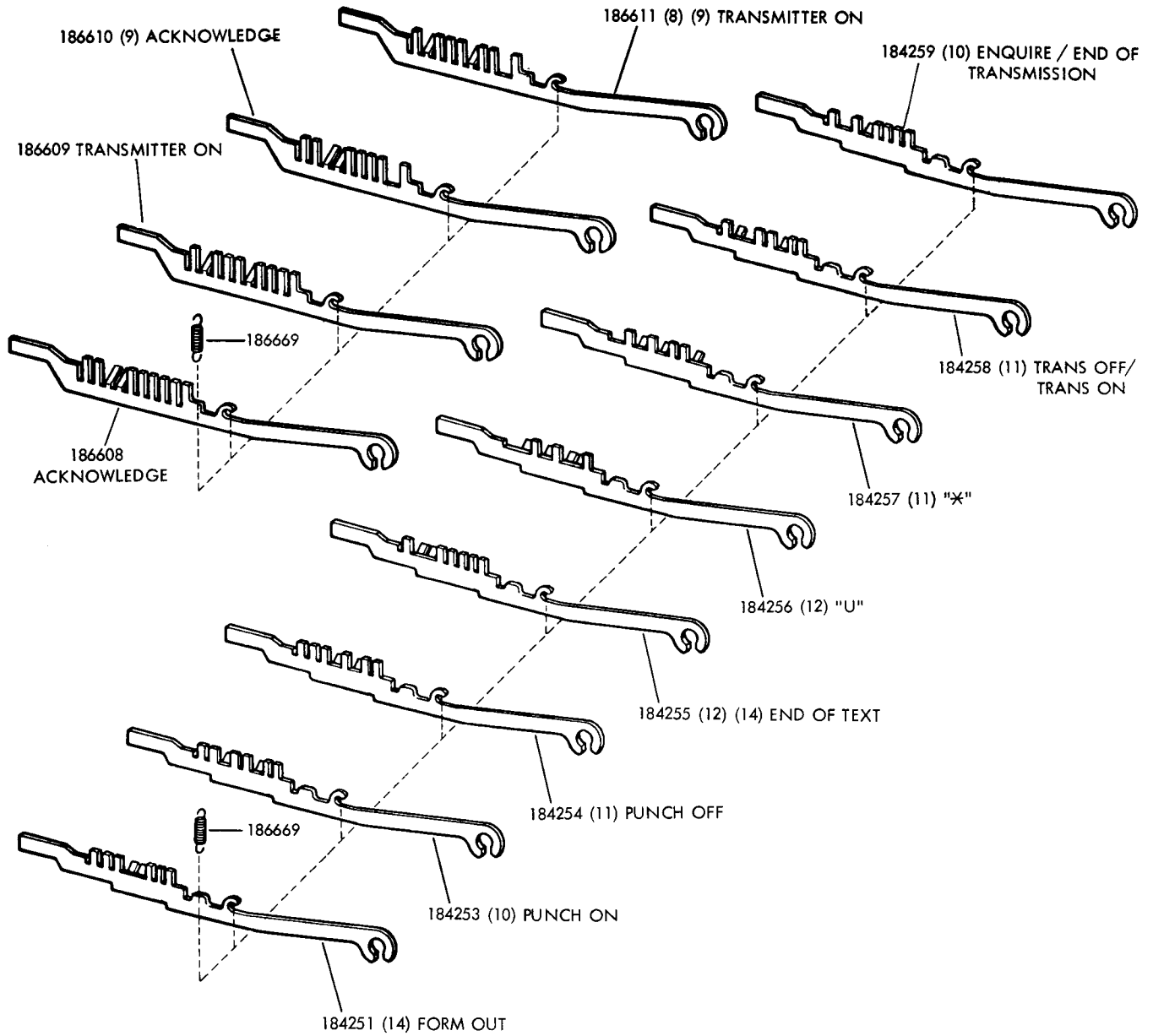

FIGURE 24. LINE FEED FUNCTION LEVER MECHANISM



NOTE: Number or letter in parenthesis () indicates slot Function Lever may occupy.

FIGURE 25. FUNCTION LEVERS



Coding a 180801 Uncoded Universal Function Lever, To perform a special function or contact closure, is to be done before installation of part. For 8 level usage starting at pivoted end, the tines are numbered 8,6,7,5,4,3,2,1 and PS, tines 6 and 7 are not in numerical order. Choose the code combination the lever is to respond to. Note marking pulses. Break off the straight tines whose number corresponds to the marking pulses. Break off the bent tines whose number corresponds to the spacing pulses.

PS-Refers to Print Suppression and is broken off when printing is desired.

On eight level codes, break both tines on position 8 unless respond to parity level (8th) is required.

Note: Number or letter in parenthesis () indicates slot Function Lever may occupy.

FIGURE 26. FUNCTION LEVERS (CONTINUED)

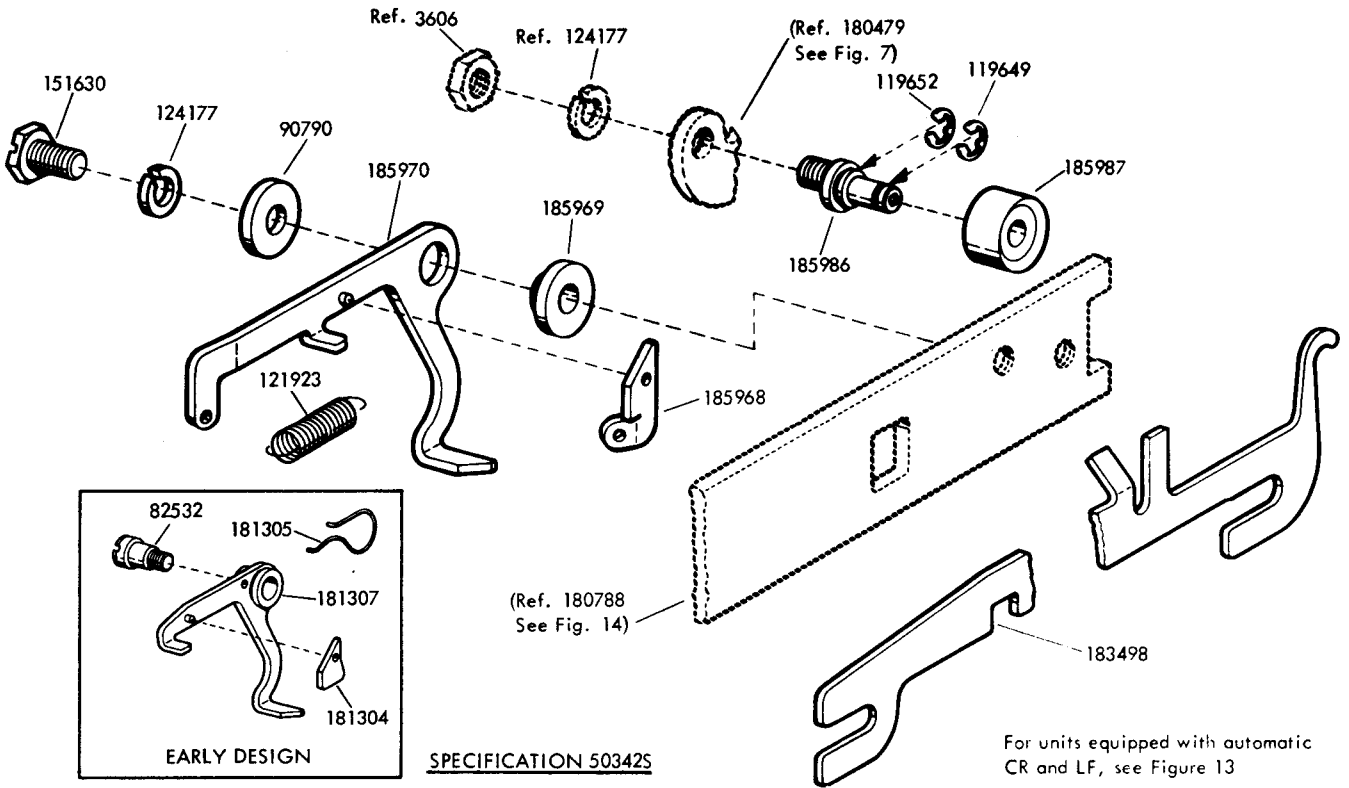

FIGURE 27. 185971 MODIFICATION KIT TO PROVIDE PRINTER WITH AN END-OF-LINE BELL TO RING ON APPROXIMATELY THE 62ND CHARACTER

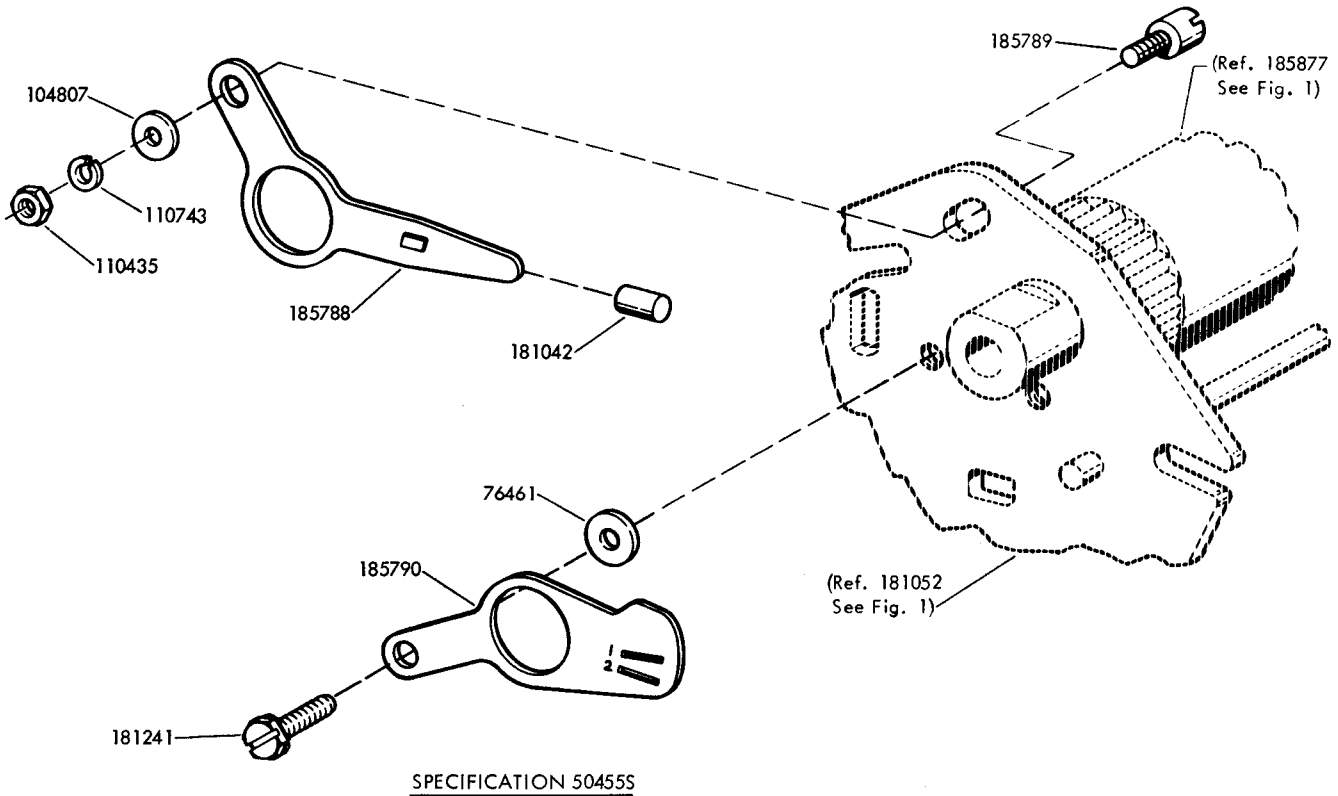

FIGURE 28. 185791 MODIFICATION KIT TO PROVIDE CONTROLLED SINGLE OR DOUBLE LINE FEED FEATURE ON FRICTION FEED PRINTER

TYPEWHEEL	PART NO.	POSITION	CHARACTER																									
			A	B	C	D	E	F	G	H	I	J	K	L	M	N	O	P	Q	R	S	T	U	V	W	X	Y	Z
MA	180598	UNSHIFT																										
		SHIFT																										
MB	182280	UNSHIFT																										
		SHIFT																										
MC	182293	UNSHIFT																										
		SHIFT																										
MD	183588	UNSHIFT																										
		SHIFT																										
ME	183599	UNSHIFT																										
		SHIFT																										
MF	183922	UNSHIFT																										
		SHIFT																										
MG	184685	UNSHIFT																										
		SHIFT																										
MH	184686	UNSHIFT																										
		SHIFT																										
MJ	184688	UNSHIFT																										
		SHIFT																										
MK	184689	UNSHIFT																										
		SHIFT																										
ML	184690	UNSHIFT																										
		SHIFT																										
MN	184691	UNSHIFT																										
		SHIFT																										
MP	184693	UNSHIFT																										
		SHIFT																										
MR	184695	UNSHIFT																										
		SHIFT																										
MS	184950	UNSHIFT																										
		SHIFT																										
MT	184694	UNSHIFT																										
		SHIFT																										
MU	184692	UNSHIFT																										
		SHIFT																										
MV	184696	UNSHIFT																										
		SHIFT																										
MW	184697	UNSHIFT																										
		SHIFT																										
MY	184698	UNSHIFT																										
		SHIFT																										
MZ	184951	UNSHIFT																										
		SHIFT																										
NA	184952	UNSHIFT																										
		SHIFT																										
NB	184953	UNSHIFT																										
		SHIFT																										

FIGURE 29. TYPEWHEEL CHART

TYPEWHEEL	PART NO.	POSITION	CHARACTER																									
			1	2	3	4	5	6	7	8	9	@	,	"	m	n	o	p	q	r	s	t	u	v	w	x	y	z
PE	184977	UNSHIFT																										
		SHIFT																										
PF	184978	UNSHIFT	J	K	L	M	N	O	P	Q	R	S	T	U	V	W	X	Y	Z	[\	^	_	0	1	2	3	4
		SHIFT																										
PG	184979	UNSHIFT	K	L	M	N	O	P	Q	R	S	T	U	V	W	X	Y	Z	[\	^	_	0	1	2	3	4	
		SHIFT																										
PH	184980	UNSHIFT																										
		SHIFT																										
PJ	184981	UNSHIFT																										
		SHIFT																										
*PL	184982	UNSHIFT																										
		SHIFT																										
PM	184983	UNSHIFT																										
		SHIFT																										
PN	184984	UNSHIFT																										
		SHIFT																										
PR	184985	UNSHIFT	a	b	c	d	e	f	g	h	i	j	k	l	m	n	o	p	q	r	s	t	u	v	w	x	y	z
		SHIFT																										
PS	186070	UNSHIFT																										
		SHIFT																										
PT	184986	UNSHIFT																										
		SHIFT																										
PW	184987	UNSHIFT																										
		SHIFT																										
PX	184988	UNSHIFT																										
		SHIFT																										
PY	184989	UNSHIFT																										
		SHIFT																										
PZ	184990	UNSHIFT																										
		SHIFT																										
RA	184991	UNSHIFT																										
		SHIFT																										
RC	184993	UNSHIFT																										
		SHIFT																										
RD	184994	UNSHIFT																										
		SHIFT																										
RF	184976	UNSHIFT																										
		SHIFT																										
RH	184998	UNSHIFT																										
		SHIFT																										
RJ	184999	UNSHIFT																										
		SHIFT																										
RL	185000	UNSHIFT																										
		SHIFT																										
SB	185484	UNSHIFT																										
		SHIFT																										

Notes : Only deviations from the basic typewheel "MA" are shown. A blank space indicates that the character for that position is identical to the basic typewheel. Solid square (■) indicates printing is suppressed in this position.

FIGURE 31. TYPEWHEEL CHART (CONTINUED)

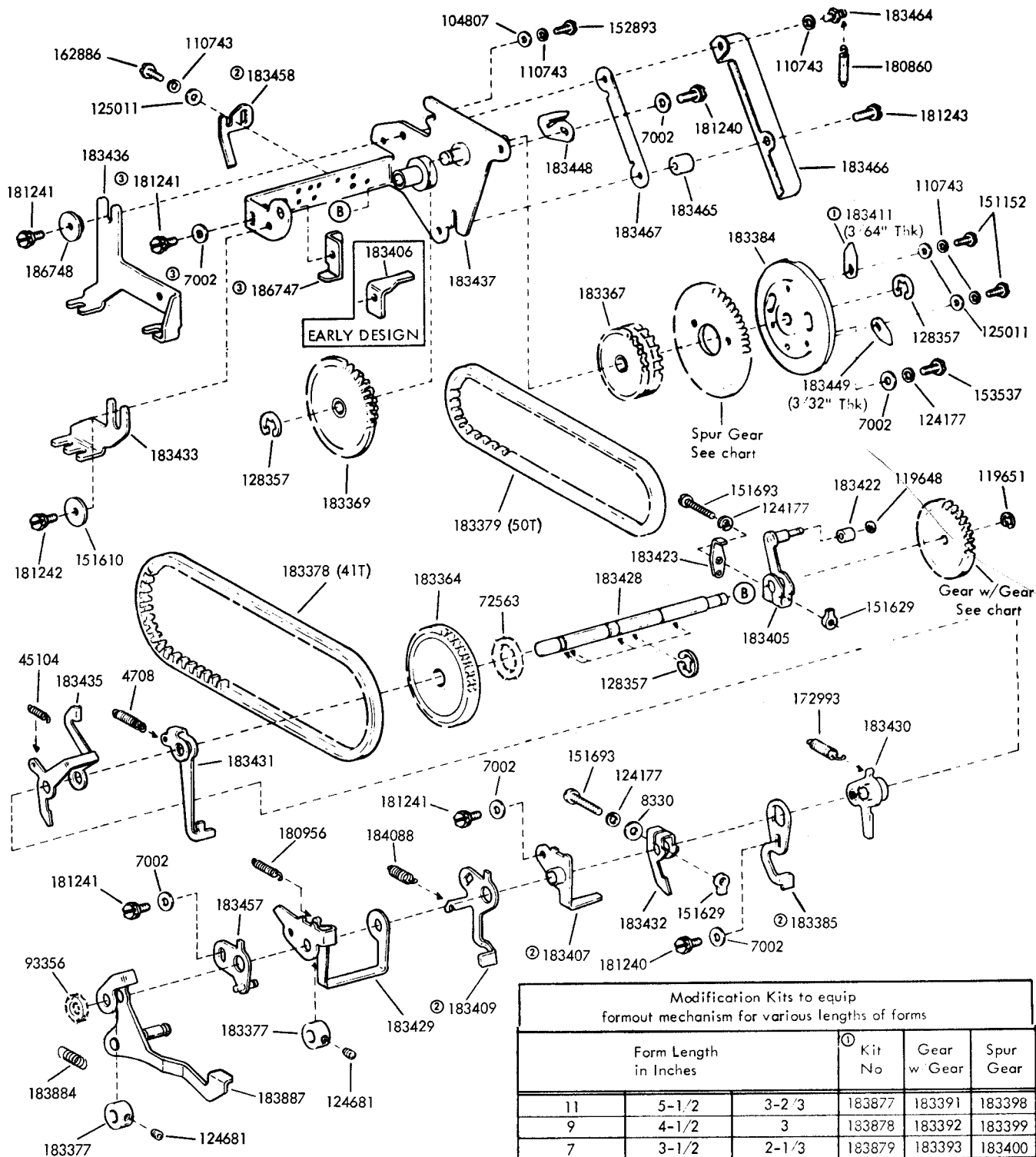

- ① The required number of 183411 Cam Plates and mounting hardware are furnished with each kit (Specification 504105)
- ② Early design parts. See Figure 33 for later design.
- ③ These parts are factory adjusted and fixturized. Should they be loosened, remove and discard them. Then readjust.

Modification Kits to equip formout mechanism for various lengths of forms					
Form Length in Inches			① Kit No	Gear w Gear	Spur Gear
11	5-1/2	3-2/3	183877	183391	183398
9	4-1/2	3	183878	183392	183399
7	3-1/2	2-1/3	183879	183393	183400
8	4	2-2/3	183880	183394	183401
8 1/2	—	2-5/6	183881	183395	183402
10	5	3-1/3	183882	183396	183403
6	—	—	183883	183397	183404

FIGURE 32. FORMOUT MECHANISM - SPROCKET FEED

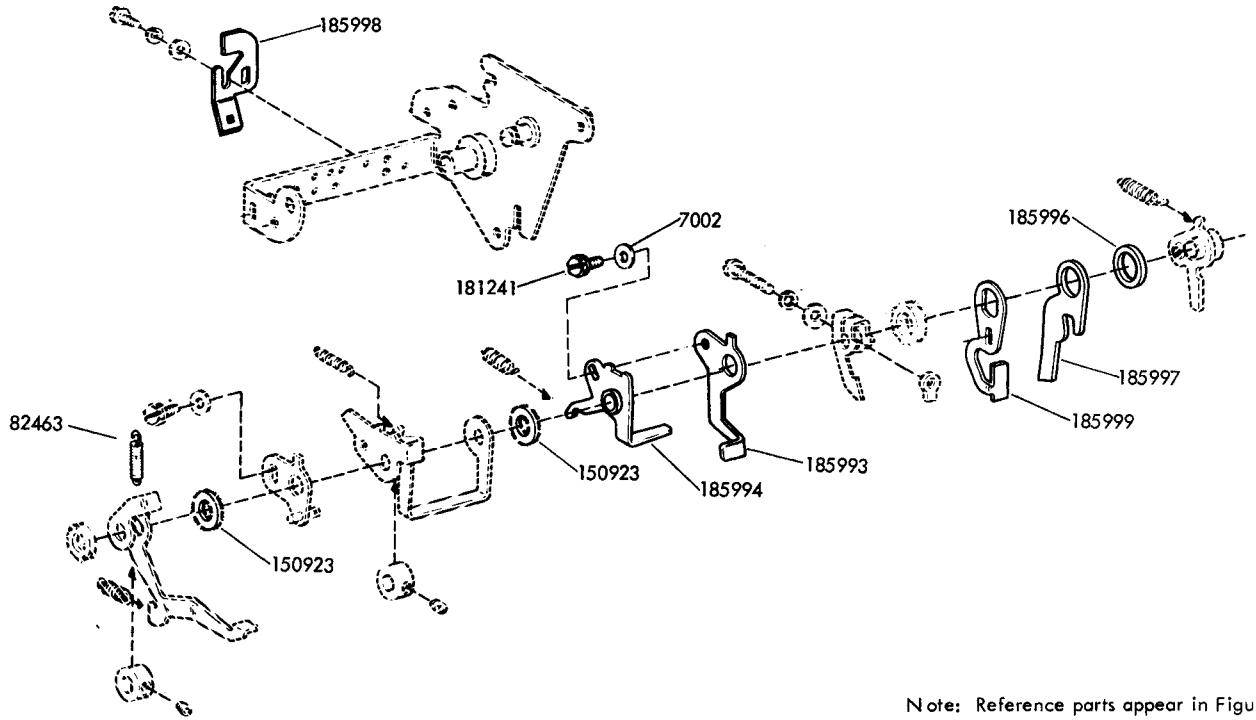

Note: Reference parts appear in Figure 32

FIGURE 33. LATER DESIGN FORMOUT MECHANISM - SPROCKET FEED

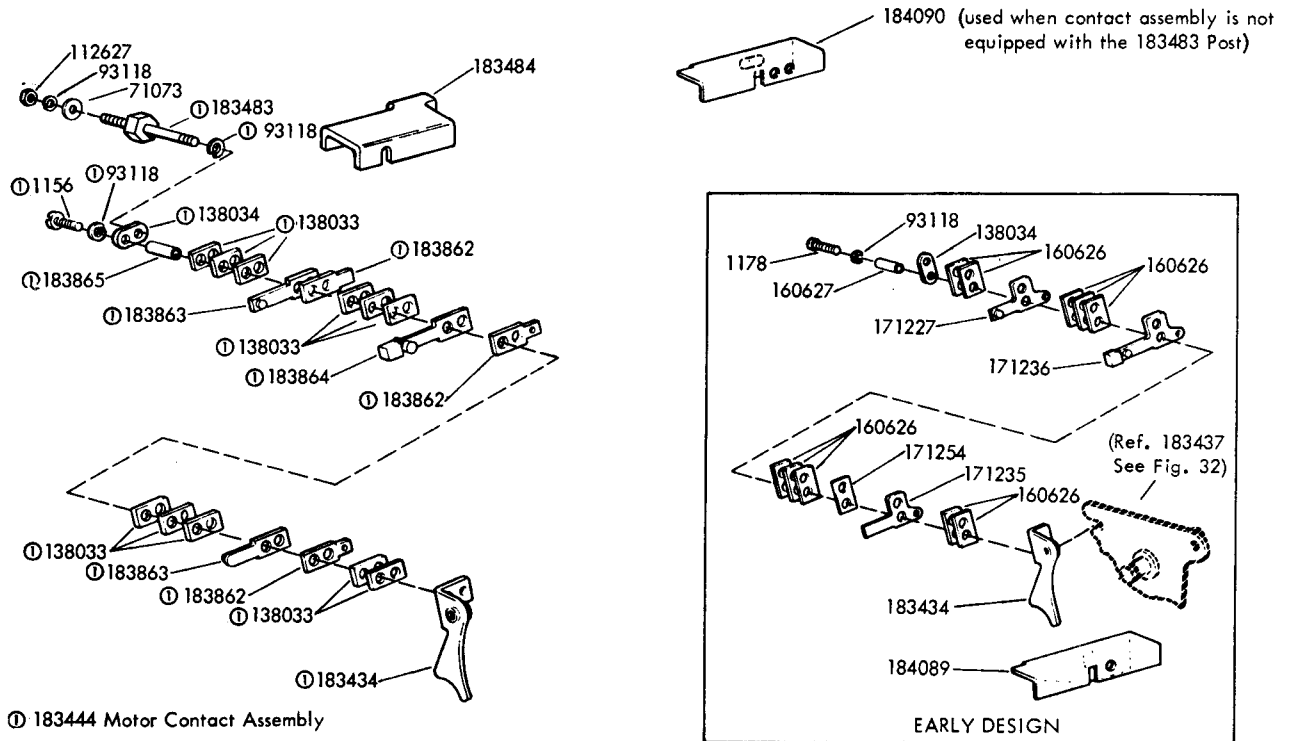

FIGURE 34. MOTOR CONTACT - SPROCKET FEED

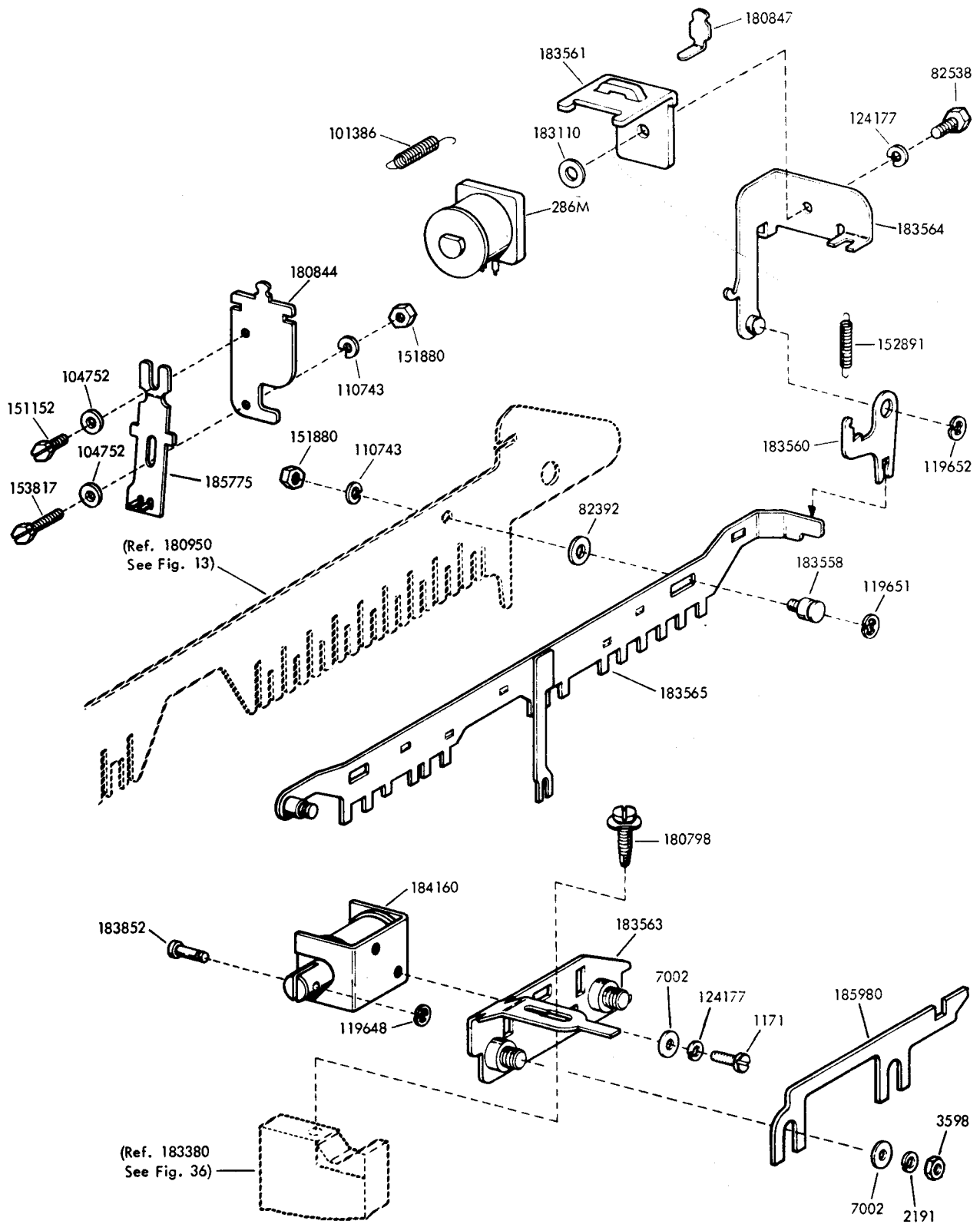
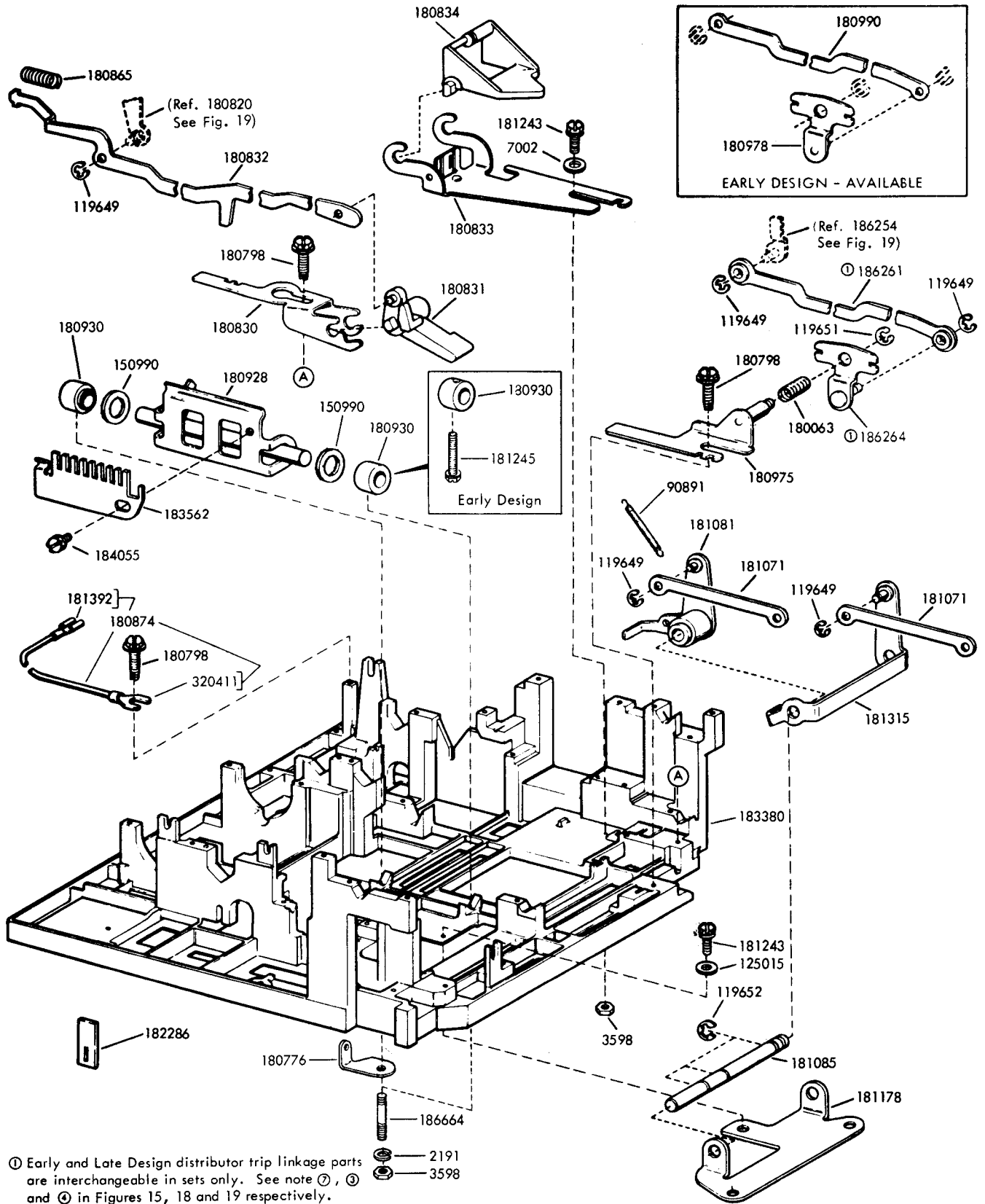

FIGURE 35. SOLENOID PRINT-NONPRINT RESET MECHANISM



① Early and Late Design distributor trip linkage parts are interchangeable in sets only. See note ②, ③ and ④ in Figures 15, 18 and 19 respectively.

FIGURE 36. BASE

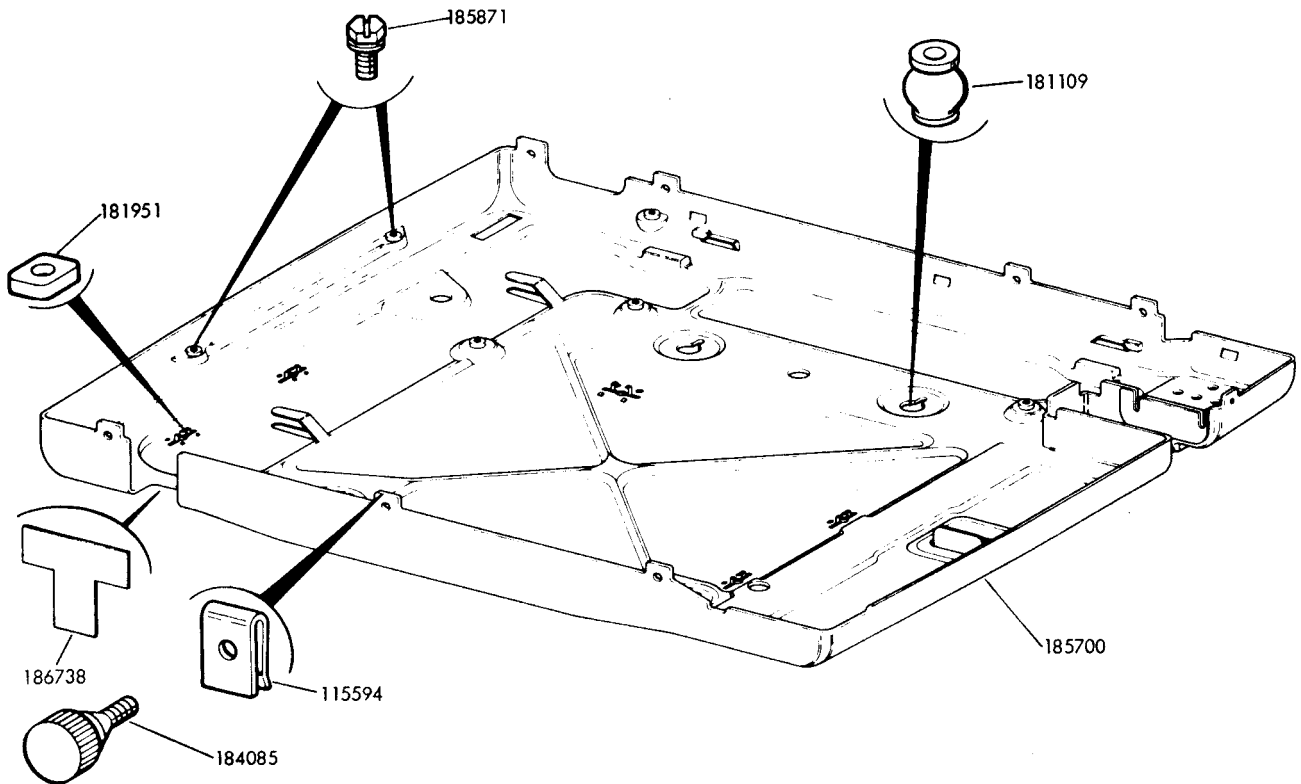
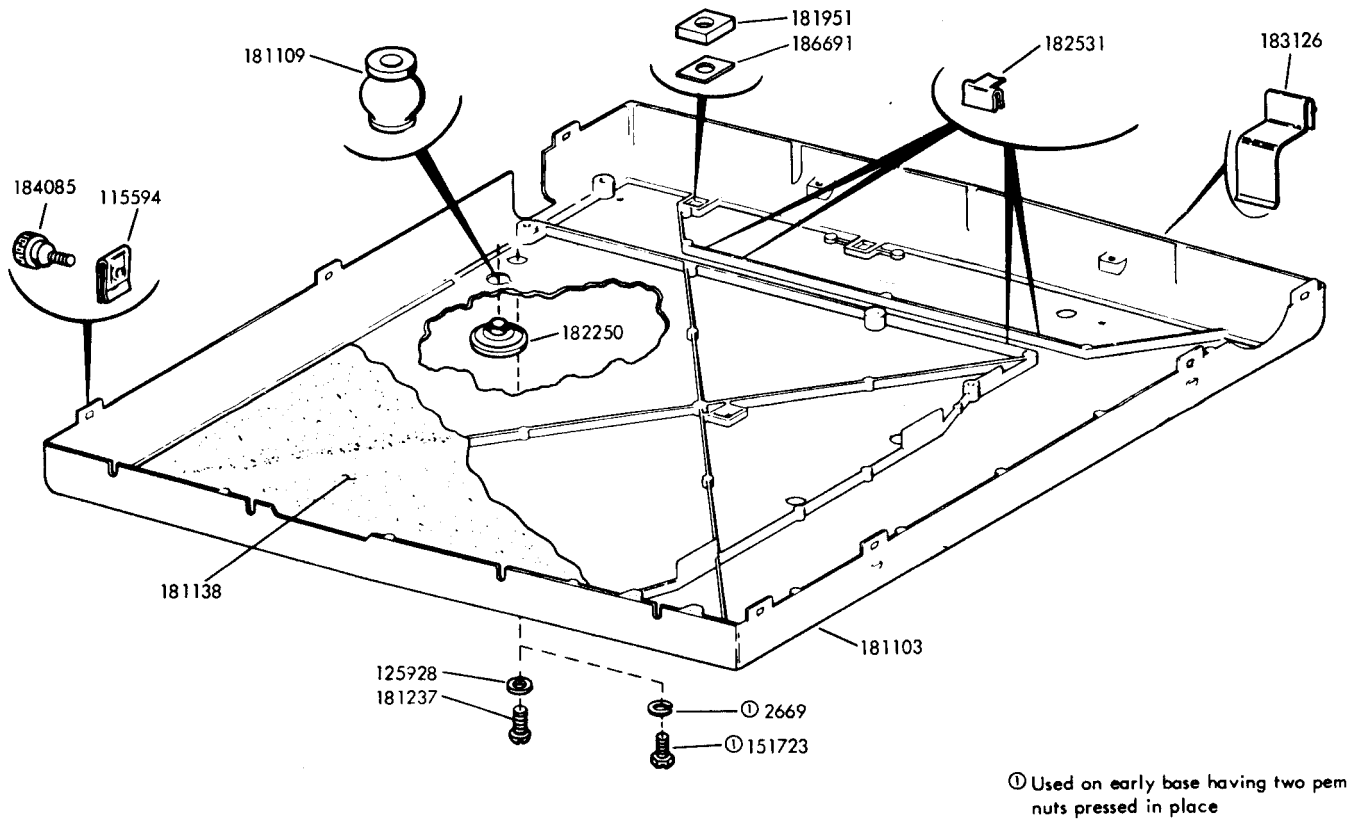
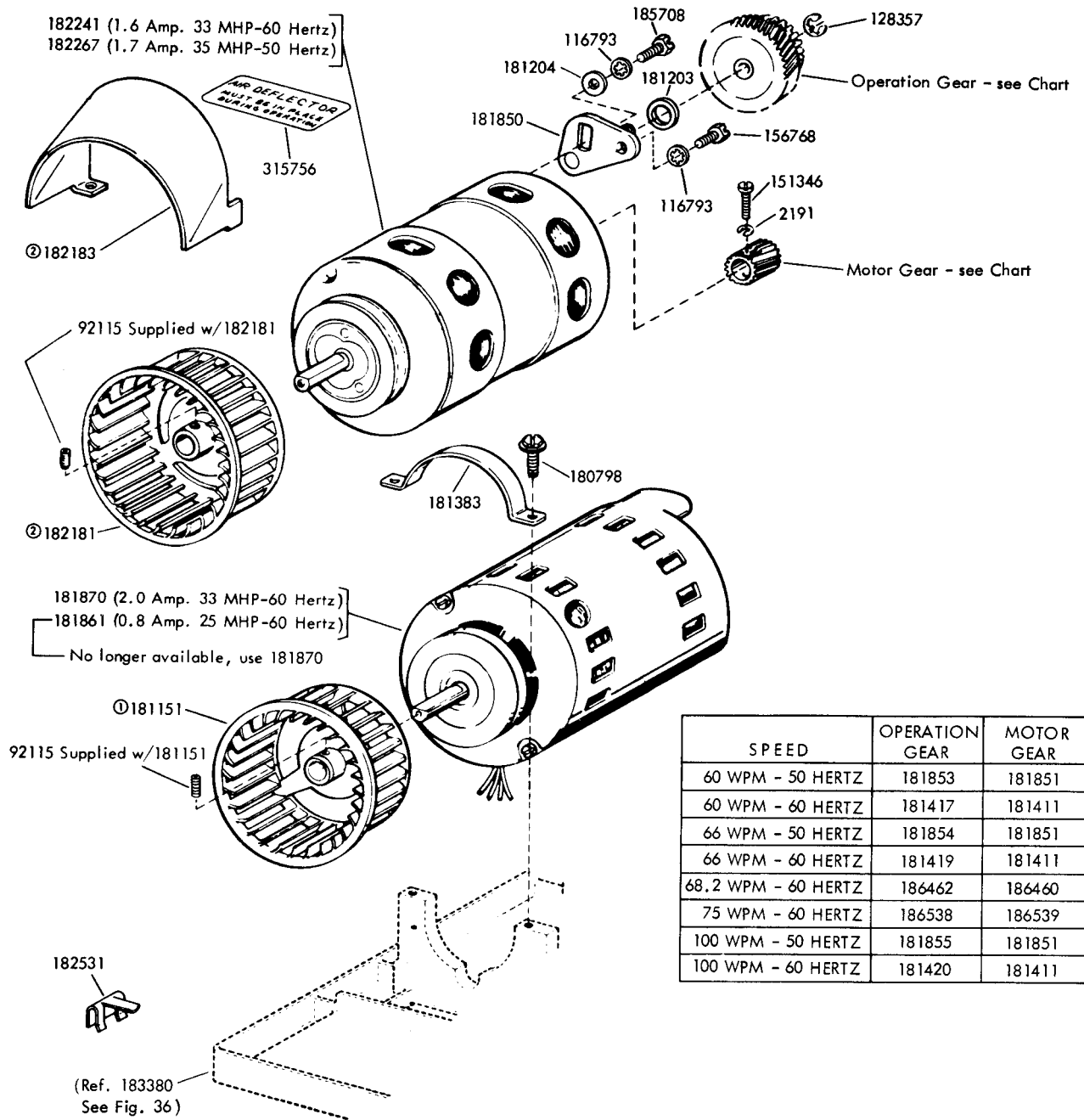

FIGURE 37. SUB BASES



SPEED	OPERATION GEAR	MOTOR GEAR
60 WPM - 50 HERTZ	181853	181851
60 WPM - 60 HERTZ	181417	181411
66 WPM - 50 HERTZ	181854	181851
66 WPM - 60 HERTZ	181419	181411
68.2 WPM - 60 HERTZ	186462	186460
75 WPM - 60 HERTZ	186538	186539
100 WPM - 50 HERTZ	181855	181851
100 WPM - 60 HERTZ	181420	181411

- ① The 181151 Fan (2-1/2" Dia.) is used with the 181870 and 182241 Motors.
- ② The 182181 Fan (3" Dia.), and the 182183 Air Deflector are used with the 182267 Motor.

FIGURE 38. MOTORS

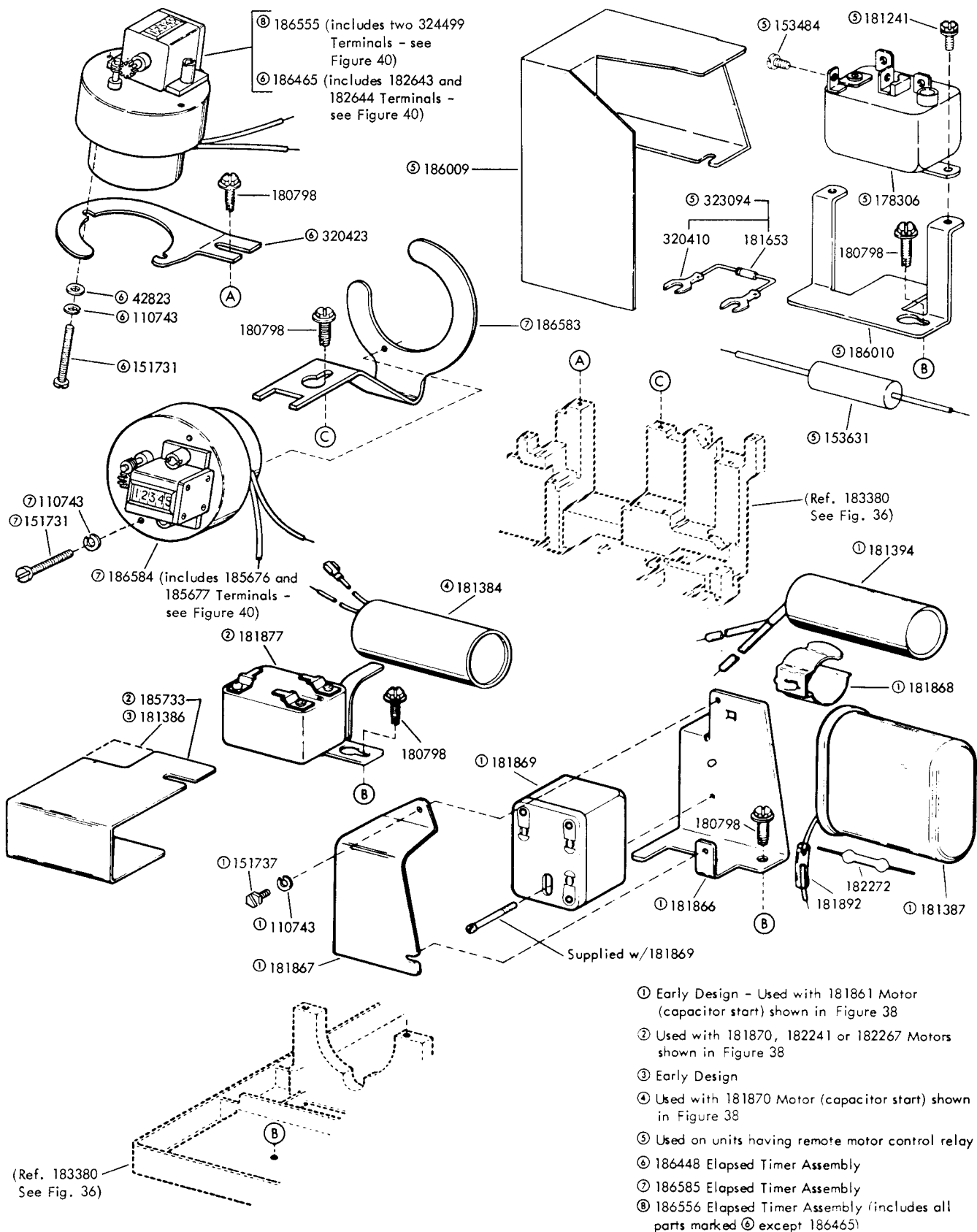

FIGURE 39. ELECTRICAL COMPONENTS

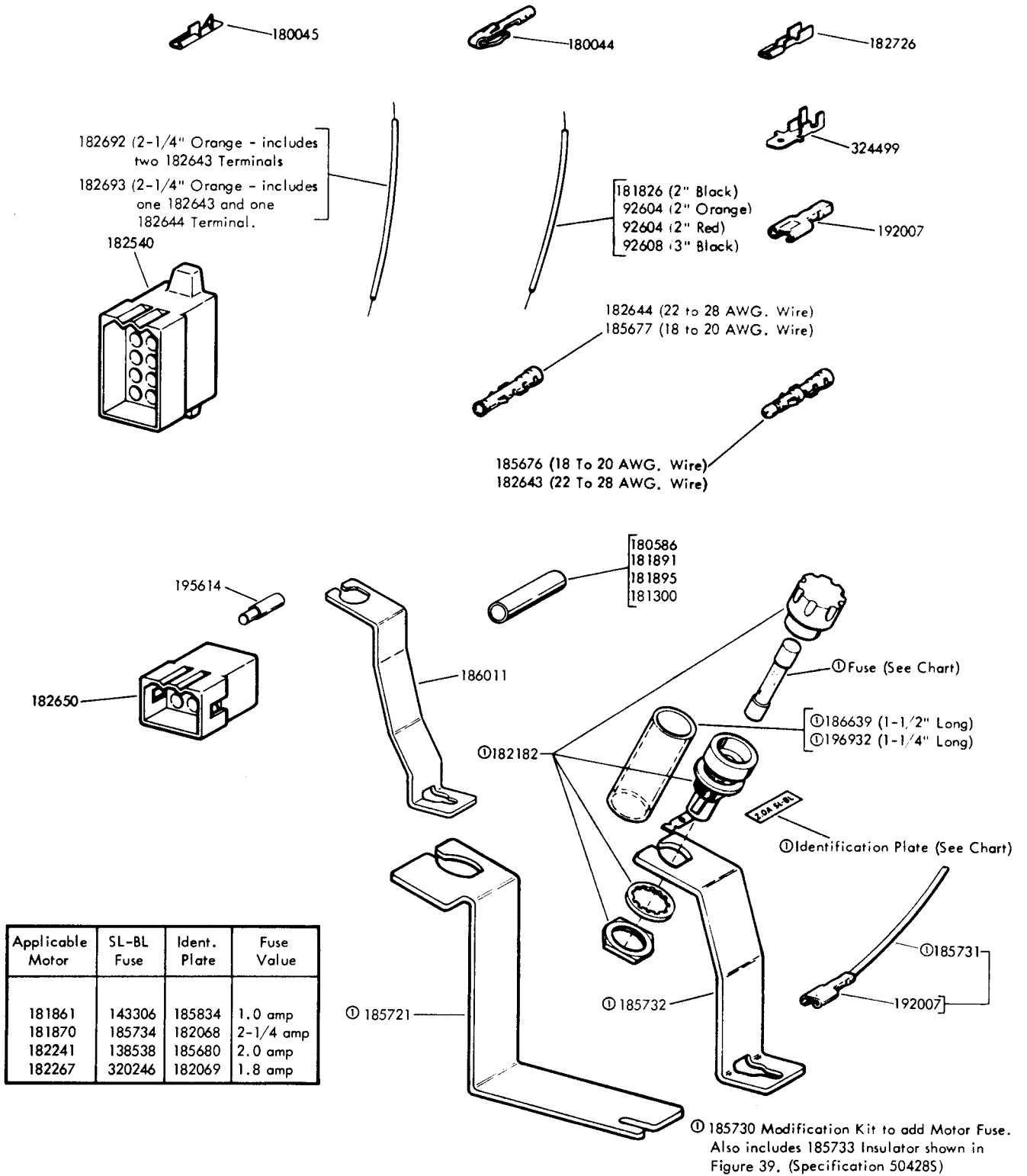

FIGURE 40. CABLE COMPONENTS

NUMERICAL INDEX

Part Number	Description and Page Number	Part Number	Description and Page Number	Part Number	Description and Page Number
272M	Coil, Magnet 22	72468	Spring 23	107116	Lockwasher 6
276M	Coil, Magnet 21	72509	Lockwasher 18	110435	Nut, 4-40 Hex 26
279M	Coil, Magnet 21	72563	Washer, Felt 30	110743	Lockwasher 4,6,7,9,10,14, 15,17,20,21,22,23,26,30, 32,36
286M	Coil, Magnet 32	74547	Collar 13	111410	Washer, Flat 9,19
295M	Coil, Magnet 21	74700	Spring 23	111640	Screw, 2-56 x 7/32 Fil 3
300M	Coil, Magnet 21	74701	Spring 10,12	112127	Hinge 17
1156	Screw, 2-56 x 9/16 Fil 31	74716	Bushing, Insulating 17	112128	Retainer 17
1164	Screw, 2-56 x 3/16 Fil 5	74722	Washer, Flat 4	112620	Screw, 4-40 x 1/2 Hex 16
1171	Screw, 6-32 x 3/16 Fil 32	76099	Washer, Flat 17	112626	Nut, 10-32 Hex 6
1178	Screw, 2-56 x 7/16 Fil 31	76422	Spring 13,22	112627	Nut, 2-56 Hex 31
1210	Screw, 2-56 x 5/8 Fil 5	76461	Washer, Flat 21,26	112630	Spring 3
2034	Washer, Flat 6,10,20,23	78103	Screw, 6-40 x 1-3/16 Hex 21	112634	Spring 6
2167	Ball, Bearing 9	80945	Spring 13	113384	Plate 17
2191	Lockwasher 2,7,9,11,12, 19,22,32,33,35	81726	Terminal 17	114107	Spring 10
2605	Spring 20	81731	Spring 8,20	115594	Nut, Speed 34
2669	Lockwasher 6,34	82392	Shim, .004" Thk 14,32	116793	Lockwasher 35
3598	Nut, 6-40 Hex 2,4,6,7,8, 9,10,14,16,17,18,19,20, 21,22,32,33	82463	Spring 31	119421	Washer, Flat 2,5
3599	Nut, 6-40 Hex 4,6,7,9,15, 20	82532	Screw, 6-40 Shoulder 26	119648	Ring, Retaining 8,10,19, 22,30,32
3606	Nut, 6-40 Hex 8,26	82538	Screw, 6-40 x 5/16 Hex 21,32	119649	Ring, Retaining 3,4,7,8, 9,10,13,15,16,17,20,26,33
3608	Spring 6	82547	Insulator, .094" Thk 17	119651	Ring, Retaining 2,3,4,6, 7,8,10,11,12,14,23,30,32, 33
3640	Lockwasher 17	82548	Insulator, .062" Thk 17	119652	Ring, Retaining 4,8,10, 19,26,32,33
3864	Spring 21	83877	Spring 17	119653	Ring, Retaining 6,20
4703	Spring 10	84226	Spring 3,20	119654	Ring, Retaining 6,20
4708	Spring 30	84575	Spring 3,8,10,14	120595	Follower, Cam 17
5599	Nut, 8-32 Hex 21	86283	Spring 15	121018	Nut, 4-40 Hex 9
7001	Washer, Flat 19	87398	Washer, Flat 4	121100	Spring 17
7002	Washer, Flat 2,3,4,5,6,7, 8,9,10,12,13,15,17,18,19, 20,22,23,30,31,32,33	87402	Spring 21	121630	Washer, Flat 21
7655	Spring 23	90361	Washer, Felt 23	121923	Spring 26
8330	Washer, Flat 13,30	90432	Washer, Flat 10	124177	Lockwasher 2,3,4,7,8,9, 10,14,15,16,17,18,20,21, 26,30,32
22746	Spring 14	90615	Spring 3	124612	Screw, 8-32 x 1/2 Hex 2
31636	Spring 5,20	90790	Washer, Flat 10,15,26	124681	Setscrew, 6-40 4,6,12,13, 16,30
33765	Washer, Flat 3	90891	Spring 33	125011	Washer, Flat 15,17,30
41732	Plate, Clamp 21	92115	Setscrew, 8-32 35	125015	Washer, Flat 14,16,17,18, 33
42661	Spring 10	92527	Lockwasher 21	125112	Screw, 2-56 x 1/8 Fil 17
42823	Washer, Flat 36	92604	Jumper, 2" Lg 37	125181	Screw, 2-56 x 3/8 Fil 16
44048	Washer, Flat 16,20	92608	Jumper, 3" Lg 37	125206	Screw, 6-32 x 5/8 Fil 11
45027	Spring 8	93117	Lockwasher 3,5,16	125252	Spring 15
45104	Spring 30	93118	Lockwasher 5,17,31	125802	Washer, Flat 15
49054	Screw, 2-56 x 3/16 Flat 6	93356	Washer, Felt 30	125928	Washer, Flat 34
49420	Spring 15	93984	Lockwasher 19		
70388	Spring 10	93985	Lockwasher 2,5,16		
70466	Spring 10	98718	Washer, Flat 19		
71073	Washer, Flat 5,16,17,31	100759	Screw, 4-40 x 3/16 Flat 11		
71681	Spool, Ribbon 6	101386	Spring 4,17,21,22,23,24, 32		
		104752	Washer, Flat 21,22,32		
		104807	Washer, Flat 7,21,26,30		

NUMERICAL INDEX (Continued)

Part Number	Description and Page Number	Part Number	Description and Page Number	Part Number	Description and Page Number
128357	Ring, Retaining 21,30,35	152890	Washer, Flat 21	180464	Pulley, Carriage Return
138033	Insulator, .031" Thk 5, 31	152891	Spring 32		Spring 10
138034	Plate, Clamp 5,31	152893	Screw, 4-40 x 1/4 Hex 6, 7,15,17,21,23,30	180466	Ring, Retaining 9
138538	Fuse, SL-BL 2 Amp 37	153267	Washer, Felt 6	180467	Bearing, Ball 9
143306	Fuse, SL-BL 1 Amp 37	153484	Screw, 6-32 Spl 36	180468	Bearing, Ball 9
145887	Spring, Contact 17	153537	Screw, 6-40 x 9/32 Hex 30	180469	Link 8,9
150026	Lever, Shoe Release 11,12	153631	Network, Spark Suppression 36	180470	Roller 8
150029	Wick, Felt 11,12,18,19	153799	Screw, 4-40 x 21/64 Hex 6,15	180471	Block 9
150040	Screw, 6-40 x 5/8 Fil 13, 18	153817	Screw, 4-40 x 3/8 Hex 4, 6,21,22,32	180473	Shaft 9
150043	Shoe, Secondary Clutch 11,12,18,19	155750	Sleeve, 3/32 ID x 1/2" Lg, Insulating 21,22	180474	Stud 9
150044	Shoe, Primary Clutch 11,12,18,19	156169	Washer, Felt 21	180475	Bushing 9
150241	Spring 11,12,18,19	156509	Washer, Flat 10	180476	Screw, 6-40 Spl 8
150830	Bushing, Shoulder 12	156536	Screw, 4-40 x 1/8 Fil 9	180477	Bracket 8
150841	Bearing 12	156558	Washer, Felt 10	180478	Guide, Nylon 8
150923	Washer, Felt 31	156572	Washer, Felt 9	180479	Bracket 8,26
150930	Washer, Felt 11,12,16	156740	Screw, 6-40 x 7/32 Hex 20	180480	Arm w/Stud 9
150990	Washer, Felt 33	156768	Screw, 8-32 x 9/32 Hex 35	180482	Arm w/Shaft 7
151152	Screw, 4-40 x 3/16 Hex 7, 9,10,21,22,30,32	157899	Arm, NC Contact 15	180483	Arm, Stop 8
151346	Screw, 6-40 x 3/8 Fil 35	158186	Screw, 4-40 x 7/32 Fil 4	180484	Arm, Stop 8
151397	Spring 17	158189	Washer, Felt 10	180485	Arm w/Spring 9
151413	Washer, Flat 10	158772	Screw, 4-40 x 5/8 Hex 21	180486	Link 8
151603	Spacer 17	160455	Spring 22	180487	Stud 9
151610	Washer, Flat 30	160626	Insulator .031" Thk 31	180488	Shaft 7
151629	Nut, 6-40 Lug 6,13,30	160627	Bushing, Insulating 31	180489	Lever w/Pin 6
151630	Screw, 6-40 x 1/4 Hex 9, 26	161100	Spring, Contact 17	180491	Shaft 9
151631	Screw, 6-40 x 5/16 Hex 3	161346	Washer, Felt 10	180492	Arm 8
151640	Lever, Shoe Release 19	161347	Washer, Felt 16	180493	Lever, Trip 8
151658	Screw, 6-40 x 5/16 Fil 11,12	162573	Retainer 12	180495	Link, Ribbon 7
151693	Screw, 6-40 x 9/16 Fil 7, 30	162881	Plate 17	180496	Arm, Stop 8
151722	Screw, 6-40 x 3/16 Hex 3, 4	162886	Screw, 4-40 x 7/32 Hex 30	180497	Spring, Print Hammer 7
151723	Screw, 10-32 x 3/8 Hex 34	164958	Screw, 4-40 x 1/2 Hex 19	180498	Bracket 6
151728	Spring 11,12,19	171227	Spring, Contact 31	180500	Frame 6,7,8,9
151731	Screw, 4-40 x 7/8 Fil 15, 36	171235	Spring, Contact 31	180501	Arm w/Stud 7,8
151737	Screw, 4-40 x 11/64 Hex 6	171236	Spring, Contact 31	180502	Head, Print Hammer 7
151880	Nut, 4-40 Hex 9,14,21,22, 32	171254	Insulator, .015" Thk 31	180503	Shaft w/Spacer 7,9
152129	Spring 22	171259	Spring 22	180505	Plate, Left Guide 7
152425	Post, Spring 17	172591	Spring, Contact Arm 15	180506	Plate, Right Guide 7
152426	Nut, 6-40 Self-Locking 17	172993	Spring 30	180508	Stud, Eccentric 8
152441	Washer, Flat 4	174034	Screw, 4-40 x 13/16 Hex 17	180509	Slide, No. 3 Pulse 8
		178306	Relay, Power 36	180510	Slide, Common 8
		180044	Terminal, Tab Type 22,37	180511	Slide, No. 1 & No. 2 Pulse 8
		180045	Terminal, Tab Type 22,37	180512	Slide w/Plates 8
		180063	Spring, Compression 33	180513	Slide, No. 5 Pulse 8
		180463	Post, Bail Pivot 10	180514	Slide, No. 4 Pulse 8
				180517	Lever, Latch 8
				180518	Plate 7
				180519	Rack 7
				180520	Arm 8
				180521	Slide, Print Suppression

NUMERICAL INDEX (Continued)

Part Number	Description and Page Number	Part Number	Description and Page Number	Part Number	Description and Page Number
180522	Bushing 8	180642	Pushbar 17	180752	Lever, Function 16
180526	Bail w/Stud 9	180643	Lever, Blocking 17	180754	Hub 16
180528	Lever w/Hub 9	180644	Lever, Blocking 17	180755	Hub 16
180534	Plate, Guide 7	180645	Lever, Selector 17	180761	Ring, Retaining 16
180537	Link 8	180646	Lever, Shoe Release 18	180763	Link 23
180538	Shaft 8	180648	Arm, Follower 13	180767	Ring, Retaining 13,15,23
180539	Bail w/Stud 8	180649	Spring 17	180768	Ring, Retaining 11,12
180540	Bail, Print Hammer 7,8	180654	Knob, Range 18	180769	Link, Left 23
180541	Plate w/Posts 6,7	180655	Plate, Side 17	180770	Link, Right 23
180543	Base, Ribbon Unit 6	180657	Bracket, Guide 17	180771	Arm 15
180544	Bail, Drive 10	180658	Shaft, Guide 17	180772	Shaft 15
180545	Bracket 10	180661	Bracket 18	180773	Plate 15
180546	Post 10	180663	Scale, Range 17	180774	Arm, Eccentric Follower 11,12
180547	Stud, Eccentric 6	180667	Plate w/Bushing 18	180776	Bracket 33
180548	Plate 7	180668	Follower, Cam 18	180777	Arm, Drive 16
180549	Bracket 7	180669	Lever, Spacing Lock 17	180778	Plate 15
180552	Post 7	180671	Lever, Start 17	180779	Bracket 15
180553	Spring 9	180672	Bail 17	180780	Blade 23
180554	Bushing 7	180673	Plate, Front 17,18	180781	Hub 15,23
180555	Spring 7	180675	Screw, No. 6 Self-Tapping 17	180782	Shaft, Pivot 23
180556	Plate, Gauge 9	180676	Nut, No. 6 Speed 17,19	180783	Casting, Function Box 15
180557	Lever w/Stud 8	180677	Arm, Trip 18	180788	Plate, Rear Rail 15,26
180558	Collar 8	180678	Plate, Spring 17	180789	Roller 15
180559	Shaft 8	180682	Upstop 10	180791	Arm w/Stud 15
180562	Link, Left Ribbon 7	180684	Latchlever 18	180792	Pawl, Function 15
180563	Stud, Eccentric 7	180685	Nut, 6-40 Spl 18	180793	Lever 24
180564	Bracket, Lock 7	180688	Core, Magnet 17	180794	Lever, Line Feed 23
180566	Hub w/Pinion 9	180691	Plate 17	180795	Bracket, Spring 23
180568	Bracket, Guide 7	180692	Spring, Flat 17	180796	Clamp 15
180569	Spring, Compression 7	180704	Armature 17	180797	Clamp 10,16,23
180571	Plate 9	180710	Plate w/Post 17	180798	Screw, 8-32 Self-Tapping 2,5,6,10,11,12,13,14,15,16,19,20,23,32,33,35,36
180574	Stud, Eccentric 9	180715	Coil, Magnet 17	180801	Lever w/Bracket 25
180575	Bearing, Ball 9,16	180717	Spring 17	180806	Camsleeve 11
180576	Bearing, Ball 9	180718	Spring 18	180807	Camsleeve 11,12
180578	Bracket w/Post 10	180719	Spring 17	180808	Spacer, .050" Thk 11
180579	Bracket w/Hub 9	180721	Wick, Felt 17	180809	Arm 16
180580	Lever w/Stud 8,9	180727	Washer, Flat 17	180813	Pawl, Function 15
180581	Roller, Typewheel 7	180728	Spring 17	180818	Lever, Function 24
180584	Lever 9	180740	Bail 15	180820	Lever, Control 20,33
180585	Spring 8	180741	Shaft, Function 16,21	180821	Lever w/Stud 20
180586	Sleeve, 5/32 ID x 21/32 Lg Insulating 8,37	180742	Roller 16	180823	Block, Contact
180591	Spring 7	180743	Bearing, Right 16	180824	Contact, Common 22
180595	Setscrew, 4-40 8	180744	Collar 6,16	180826	Lever, Detent 22
180598	Typewheel, MA 27	180745	Arm w/Stud 16	180827	Drum, Answer Back 22
180606	Bail 9	180746	Arm w/Bushing 11,12,16	180828	Pawl, Feed 20
180607	Arm, Adjusting 9	180748	Arm w/Stud 16	180829	Screw, 4-40 Shoulder 20
180608	Bracket, Left 2,5	180749	Arm w/Stud 16	180830	Bracket 33
180610	Shield 7	180750	Arm w/Stud 16		
180641	Camsleeve 18	180751	Arm w/Stud 16		

NUMERICAL INDEX (Continued)

Part Number	Description and Page Number	Part Number	Description and Page Number	Part Number	Description and Page Number
180831	Lever 33	180964	Roller 19	181028	Camsleeve 11
180832	Link, Tie 33	180967	Shaft, Distributor 19	181030	Bracket w/Stud 2
180833	Bracket, Adjusting 33	180968	Buffer 20	181034	Platen 2
180834	Bail, Trip 33	180969	Bearing 19	181037	Bracket, Right 2
180835	Pawl, AB Blocking 15	180970	Bearing 19	181038	Bracket, Left 2,5,9
180836	Lever, Blocking Function 24	180971	Shaft, Trip 20,22	181039	Knob, Platen 2
180837	Link, Blocking 20	180972	Clamp, Buffer 20	181040	Pawl, Detent 2,4
180838	Lever, Function 24	180973	Disc, Spacer 19	181041	Retainer 2,4
180842	Spacer, .050" Thk 22	180975	Bracket w/Stud 33	181042	Tip, Rubber 3,26
180843	Lever, Trip 20,22	180978	Lever w/Stud 33	181044	Roller, Pressure 3
180844	Armature 21,22,32	180979	Brush, Carbon 19	181045	Post, Support 2,5,21
180847	Bracket, Spring 21,22,32	180980	Holder, Brush 19	181048	Bracket, Stop 2
180850	Bracket, Magnet 19,21,22	180981	Arm, Stop 20	181049	Arm, Right 3
180854	Brace 22	180982	Bail, Trip 20	181050	Arm, Left 3
180855	Latch, Blocking 22	180983	Lever, Latch 20	181051	Bracket, Left 3
180858	Contact, Wire 22	180985	Lever, Follower 20	181052	Plate 2,26
180860	Spring 16,20,30	180987	Disc 19,22	181053	Bail, Paper Straightener 3
180861	Spring 20	180988	Bracket, Spring 20	181054	Shaft, Pressure 3
180862	Spring 22	180989	Screw, No.6 Spl 19,22	181055	Bar 2,3
180863	Spring 15,20	180990	Link Keyboard 33	181056	Guideplate, Pressure Roller 3
180864	Spring, Extension 20	180991	Cam, Blocking 19	181057	Bracket, Right 3
180865	Coil, Adjusting 33	180992	Spring, Torsion 19	181058	Guideplate, Paper 3
180874	Strap, 4-1/2" Braided 33	180994	Spacer, .015" Thk 19	181062	Eccentric, Toggle Link 10
180920	Shaft 14	180995	Spacer, .114" Thk 19,21, 22	181065	Pawl, Check 10
180922	Spring 14	180997	Disc w/Plate 19	181066	Shaft, Spacing Drum 6
180923	Bracket w/Studs 14,22	180998	Clamp 16,19	181067	Pawl, Feed 10
180925	Clamp 14	180999	Bearing, Left 16	181068	Lever w/Post 10
180926	Ring, Retaining 14	181000	Drum, Clutch 11,12,18	181069	Drum, Spacing 6
180927	Ring, Retaining 13,14	181001	Bearing 11,12	181070	Lever, Suppression 10
180928	Bail 33	181002	Bearing 11,12	181071	Link 10,33
180930	Bearing 33	181003	Latchlever, 13	181072	Bracket w/Post 6
180932	Bar, No.8-1 Code 14	181004	Hub 13	181074	Pulley 6
180933	Bar, No.8-2 Code 14	181005	Link, Carriage 10,11	181075	Belt, 127T 6
180934	Bar, No.8-3 Code 14	181006	Bushing 13	181076	Roller 10
180935	Bar, No.8-4 Code 14	181007	Shaft, Main 11,18	181077	Ratchet, Spacing 6
180936	Bar, No.8-5 Code 14	181008	Collar 11,12	181078	Stud 10
180937	Bar, No.8-6 Code 14	181010	Lever w/Stud 13	181079	Washer, Flat 6
180938	Bar, No.7 Code 14	181011	Lever w/Nut 13	181081	Arm w/Hub and Post 33
180939	Bar, No.8 Code 14	181012	Spacer 13	181082	Eccentric, Toggle Link 10
180947	Bar, Spring Suppression Code 14	181013	Spacer, .453" Thk 13	181083	Lever 24
180948	Bar, Auto CR & EOL Bell Code 14	181014	Grommet, Rubber 13	181084	Bracket 6
180949	Bracket, Rear Tie 14	181015	Gear, 35T 12	181085	Shaft 33
180950	Bracket, Front Tie 14,32	181017	Plate 13	181086	Lever w/Hub 10
180956	Spring 4,14,30	181018	Shaft 13	181088	Post 10
180957	Bracket, Spring 14	181019	Lever, Trip 13	181089	Arm w/Hub 10
180958	Nut, 6-40 Lug 17	181020	Lever 13	181091	Link w/Post, Toggle 10
180959	Bracket 17	181021	Spacer, .406" Thk 13	181092	Bracket, Belt 6
		181022	Bracket, Left 11,12,13	181093	Bracket, Extension 6
		181023	Bracket, Right 13		

NUMERICAL INDEX (Continued)

Part Number	Description and Page Number	Part Number	Description and Page Number	Part Number	Description and Page Number
181094	Bracket w/Post 10	181241	Screw w/Lockwasher, 6-40 X 1/4 Hex 8,10,12,13,15, 17,20,23,26,30,31,36	181409	Belt, 47T 19
181103	Cover, Base 34	181242	Screw w/Lockwasher, 6-40 x 5/16 Hex 2,3,4,5,7,8, 11,12,16,17,19,20,21,30	181411	Pinion, 18T 35
181104	Clip, Cable 5,21	181243	Screw w/Lockwasher, 6-40 x 3/8 Hex 6,16,21,22,30, 33	181413	Drum, Clutch 19
181109	Mount, Vibration 34	181245	Screw w/Lockwasher, 6-40 x 1/2 Hex 2,21,33	181414	Pulley, 34T 19
181111	Pawl, Feed 6	181246	Screw w/Lockwasher, 6-40 x 5/8 Hex 11,12,13	181417	Pulley w/68T Gear, 13T 35
181113	Spring, Compression 6	181249	Screw w/Lockwasher, 6-40 x 1 Hex 21	181419	Pulley w/62T Gear, 13T 35
181114	Lever 6	181250	Screw, No.2 Self-Tapping 15	181420	Pulley w/54T Gear, 17T 35
181115	Stud 6	181278	Clamp 15	181424	Nut, 6-40 Sq 11,12
181116	Arm, Reverse 6	181279	Bracket 21	181425	Plate 11
181117	Pawl, Retaining 6	181284	Spring 18	181426	Plate, Spacer 11
181118	Spring 6	181300	Sleeve, 3/16 ID x 1" Lg Insulating 37	181427	Plate, Nut 11
181119	Spring 6	181304	Latch 26	181440	Bracket, Switch 16
181120	Spring, Compression 4,6	181305	Spring 26	181441	Switch 16
181121	Pin 6	181307	Lever w/Post 26	181449	Plate, Contact 15
181122	Disc 6	181312	Latch, Carriage Return 6	181450	Block, Contact 15
181123	Nut, 4-40 Spl 6	181314	Link w/Post 10	181460	Plate w/Post 15
181124	Post 6	181315	Bail w/Post 33	181461	Gong 15
181125	Ratchet, Left Ribbon 6	181316	Shaft 10	181464	Clapper 15
181126	Ratchet, Right Ribbon 6	181317	Hub, Carriage Return Lever 10	181500	Link, Drive 3
181129	Ribbon w/Spool 6	181318	Lever, Actuating 24	181501	Upstop, Line Feed Link 3
181138	Pad 34	181319	Lever, Carriage Return 10	181503	Bracket, Guide 23
181151	Fan 35	181320	Lever, Unlatch 10	181521	Spring, Platen 3
181164	Shaft w/Link 3	181322	Pawl, Function 15	181522	Guide, Paper 3
181165	Pawl, Feed 3	181323	Spring 8	181523	Spring 2,4
181166	Bracket, Line Feed 3	181324	Pawl, Function 15	181524	Nut, 2-56 Shoulder 3
181168	Bellcrank w/Studs 3	181325	Pawl, Function 15	181525	Guide, Paper 3
181172	Lever, Function 24	181326	Arm 6	181570	Lever 24
181173	Stud, Feed Pawl Stop 2	181327	Latch 6	181571	Lever 24
181174	Guide 16	181328	Lever 10	181572	Lever 24
181175	Plate, Stripper 3	181383	Clamp, Motor 35	181573	Lever 24
181176	Link, Adjusting 3	181384	Capacitor, 88-108 MFD 36	181574	Lever 24
181178	Bracket 33	181386	Insulator 36	181575	Lever 23
181179	Lever, Blocking 23	181387	Capacitor, 5 MFD 36	181576	Lever 24
181191	Spring, Compression 9	181392	Terminal, Tab Type 33	181580	Lever 24
181193	Cylinder 2,5	181394	Capacitor, 47-56 MFD 36	181581	Lever 24
181194	Washer, Flat 9	181405	Plate 13	181582	Lever 24
181195	Washer, Cup 9	181406	Roller 13	181583	Lever 24
181196	Ring, Retaining 9			181585	Lever 24
181197	Plate, Adjusting 2,5			181586	Pawl, Blocking 15
181198	Bumper 9			181653	Diode 36
181199	Piston 9			181826	Jumper, 2" Black 37
181203	Washer, Flat 35			181850	Plate w/Stud 35
181204	Washer, Flat 35			181851	Gear, 17T 35
181230	Plate 10			181853	Pulley w/66T Gear, 16T 35
181231	Screw, 8-32 Self-Tapping 16,21			181854	Pulley w/60T Gear, 16T 35
181237	Screw, 1/4-14 Self-Tapping 34			181855	Pulley w/40T Gear, 16T 35
181240	Screw w/Lockwasher, 6-40 x 3/16 Hex 2,5,10,17,23, 30			181861	Motor, 115V AC Synchronous 35,36,37
				181866	Bracket 36
				181867	Insulator 36

NUMERICAL INDEX (Continued)

Part Number	Description and Page Number	Part Number	Description and Page Number	Part Number	Description and Page Number
181868	Clip, Speed 36	182277	Spring 20	183059	Bushing, Insulating 21
181869	Relay, Motor Start 36	182280	Typewheel, MB 27	183060	Terminal, Lug 21
181870	Motor, 115V AC Synchronous 35,36,37	182286	Insulator, .032" Thk 15, 33	183062	Cover, Contact 21
181877	Relay w/Bracket 36	182290	Modification Kit 15,24	183098	Lever, Trip 21
181891	Sleeve, 3/16 ID x 2-1" Lg Insulating 37	182291	Modification Kit 15,24	183110	Shim, .004" Thk 21,32
181892	Sleeve, 9/64 ID x 1" Lg Insulating 36	182293	Typewheel, MC 27	183126	Clip 34
181895	Sleeve, 9/64 ID x 3/8" Lg Insulating 37	182310	Bar, No.8-1 Code 14	183130	Insulator 21
181951	Insert, Nylon 34	182311	Bar, No.8-2 Code 14	183301	Plate, Paper Guide 4
181952	Stud 2	182312	Bar, No.8-3 Code 14	183303	Knob, Disengaging 4
181954	Typewheel, NJ 6	182313	Bar, No.8-4 Code 14	183304	Knob, Sprocket 4
181955	Washer, Pulley 6	182314	Bar, No.8-5 Code 14	183308	Plate, Right 4,5
191956	Drum, Spacing 6	182315	Bar, No.8-6 Code 14	183309	Plate, Left 4,5
181957	Belt, 151T 6	182316	Bar, No.7 Code 14	183310	Platen 4
181983	Screw, 6-40 x 5/8 Spl 15	182317	Bar, No.8 Code 14	183313	Bar 4
182015	Lever Assembly Clutch Trip 1,13	182318	Bar, R Code 14	183314	Guide, Right Paper 4
182037	Switch Assembly, Contact 15	182318	Bar, R Code 14	183315	Guide, Left Paper 4
182047	Clutch Assembly 11,12	182330	Bar, No.8-A Code 14	183316	Bracket 4
182056	Modification Kit 6	182461	Bracket, Upstop 10	183317	Bracket, Right 4
182068	Plate, Identification 37	182531	Clip, Speed 34,35	183318	Bracket, Left 4
182069	Plate, Identification 37	182540	Connector, 15 Pt Plug Type 22,37	183319	Detent, 21T 4
182137	Contact Assembly 21	182643	Terminal, Plug Type 22, 36,37	183320	Pulley, 21T 4
182155	Plate, Right 7	182644	Terminal, Receptacle Type 36,37	183321	Sprocket, Feed 4
182156	Plate, Left 7	182650	Connector, 4 Pt Plug Type 37	183322	Pulley, 21T 4
182157	Bushing, Shoulder 7	182677	Cable w/Terminals 22	183323	Bracket, Right 5
182181	Fan 35	182692	Jumper, 2-1/4" Orange 37	183324	Arm, Reverse 6
182182	Holder, Fuse 37	182726	Terminal, Receptacle Type 37	183326	Guide, Bracket 6,7
182183	Deflector, Air 35	182693	Jumper, 1-1/4" Orange 37	183330	Guide 6
182232	Roller 19	182894	Link 21	183335	Guide, Left 4
182237	Pawl, Function 15	182895	Plate w/Bushing 21	183336	Guide, Right 4
182239	Lever, Latch 20	182898	Arm 21	183338	Knob w/Pin 4
182241	Motor, 60 Cycle Synchronous 35,36,37	182900	Link w/Post 21	183339	Plunger Assembly 4
182244	Lever, Cam Follower 20	182902	Spacer, .469" Thk 21	183341	Wheel, Idler 4
182250	Foot, Rubber 34	182955	Link, Support 21	183346	Ring, Retaining 4
182262	Arm, Stop 20	182957	Plate 27	183349	Washer, Felt 4
182263	Bracket 20	182958	Spacer 21	183351	Stud, Idler 4
182264	Stud 20	182960	Plate 21	183352	Guide, Paper 4
182267	Motor, 50 Cycle Synchronous 35,36,37	182961	Sleeve 21	183356	Washer, Supporting 4
182268	Lever, Cam Follower 20	182964	Arm Assembly, Drive 1,21	183357	Spring, Compression 4
182269	Modification Kit 20	183052	Bracket, Contact 21	183358	Plate 5
182272	Resistor, 10 Ohm 36	183053	Stiffener, Front 21	183360	Arm 16
182276	Lever, Answer-Back Trip 20,22	183054	Stiffener, Rear 21	183361	Disc 12
		183055	Spring, Contact 21	183364	Pulley w/20T Gear, 30T 30
		183056	Spring, Contact 21	183367	Pulley w/28T Gear, 21T 30
		183057	Insulator, .031" Thk 21	183369	Pulley w/35T Gear, 21T 30
		183058	Insulator, .062" Thk 21	183371	Bearing, Sleeve 12
				183372	Lever, Shoe Release 12
				183373	Disc, 6 Stop 12
				183374	Disc, 6 Stop 12
				183376	Collar 12
				183377	Collar 30

NUMERICAL INDEX (Continued)

Part Number	Description and Page Number	Part Number	Description and Page Number	Part Number	Description and Page Number
183378	Belt, 41T 30	183437	Bracket 30,31	183876	Screw, 6-32 Set 4
183379	Belt, 50T 30	183438	Stud 4	183877	Modification Kit 30
183380	Casting, Frame 2,5,6,8, 10,11,12,13,14,15,16,17, 19,20,22,23,32,33,35,36	183442	Lever w/Hub 4	183878	Modification Kit 30
183381	Washer, Flat 12	183443	Bracket 5	183879	Modification Kit 30
183382	Shaft, Main 12	183444	Contact Assembly 31	183880	Modification Kit 30
183383	Pulley, 15T 12	183445	Contact Assembly 5	183881	Modification Kit 30
183384	Disc 30	183448	Pointer 30	183882	Modification Kit 30
183385	Arm, Stop 30	183449	Plate, Index 30	183883	Modification Kit 30
183387	Pawl, Function 15	183450	Screw, 4-40 x 7/32 Flat 12	183884	Spring 30
183388	Pawl, Function 15	183454	Retainer, Spring 4	183887	Bail, L.F. 30
183389	Arm 12	183457	Plate 30	183922	Typewheel 27
183390	Arm w/Stud 16	183458	Plate, Stop 30	183993	Camsleeve 11,12
183391	Gear, 16T 30	183464	Post, Spring 30	183994	Link 9,10,11,12
183392	Gear, 20T 30	183465	Spacer 30	183995	Lever 9
183393	Gear, 40T 30	183466	Bracket 30	183996	Link, Toggle 10
183394	Gear, 20T 30	183467	Insulator 30	183998	Clutch Assembly 11,12
183395	Gear, 24T 30	183468	Lever, Strip 23	183999	Spacer, .050" Thk 11,12
183396	Gear, 20T 30	183469	Plate 23	184006	Screw, 8-32 Self-Tapping 8,10,13,15,22
183397	Gear, 24T 30	183474	Modification Kit 6,7	184055	Screw w/Lockwasher, 6-24 x 3/16 Hex 33
183398	Gear, 44T 30	183483	Post 31	184085	Screw, 8-32 Thumb 34
183399	Gear, 45T 30	183484	Cover, Contact 31	184088	Spring 30
183400	Gear, 70T 30	183492	Clutch Assembly 12	184089	Shield 31
183401	Gear, 40T 30	183495	Bar, Code 14	184090	Shield 31
183402	Gear, 51T 30	183496	Bar, Code 14	184096	Bracket 10
183403	Gear, 50T 30	183497	Bar, Code 14	184148	Contact, Wire 22
183404	Gear, 36T 30	183498	Bar, Code 14,26	184149	Drum, Answer-Back 22
183405	Bail 30	183499	Lever, Blocking 23	184157	Modification Kit 23
183406	Bracket, Stop 30	183503	Housing, Bearing 9	184160	Solenoid 32
183407	Arm 30	183504	Retainer, Bearing 9	184201	Lever 20
183408	Arm 12	183510	Cable Assembly 22	184251	Lever w/Bracket 25
183409	Arm, Latch 30	183552	Lever 24	184253	Lever 25
183411	Plate, Cam 30	183558	Post 14,32	184254	Lever 25
183415	Roller 19	183560	Lever 32	184255	Lever 25
183418	Shaft, Distributor 19	183561	Bracket, Magnet 32	184256	Lever 25
183422	Roller 30	183562	Bracket 33	184257	Lever 25
183423	Bracket, Spring 30	183563	Bracket 32	184258	Lever 25
183425	Clamp 15,16	183564	Bracket w/Stud 32	184259	Lever 25
183426	Clamp 15	183565	Bar w/Link 32	184280	Knob Assembly 4
184428	Shaft 30	183567	Bar 14	184685	Typewheel, MG 27
183429	Bail 30	183588	Typewheel, MD 27	184686	Typewheel, MH 27
183430	Arm 30	183599	Typewheel, ME 27	184688	Typewheel, MJ 27
183431	Bail, Clutch Latch 30	183851	Retainer, Left 23	184689	Typewheel, MK 27
183432	Bail, Reset 30	183852	Pin 32	184690	Typewheel, ML 27
183433	Bracket, Side 30	183853	Retainer, Right 23	184691	Typewheel, MN 27
183434	Bracket, Contact Switch 31	183861	Plate, Stop 5	184692	Typewheel, MU 27
183435	Bail, Contact Switch 30	183862	Terminal 5,31	184693	Typewheel, MP 27
183436	Bracket 30	183863	Spring, Contact 5,31	184694	Typewheel, MT 27
		183864	Spring, Contact 5,31	184695	Typewheel, MR 27
		183865	Bushing, Insulating 5,31		

NUMERICAL INDEX (Continued)

Part Number	Description and Page Number	Part Number	Description and Page Number	Part Number	Description and Page Number
184696	Typewheel, MV 27	185000	Typewheel, RL 29	186011	Bracket 37
184697	Typewheel, MW 27	185484	Typewheel, SB 29	186014	Bracket, Contact 17
184698	Typewheel, MY 27	185676	Terminal, Plug Type 21, 22,36,37	186025	Contact Assembly 17
184950	Typewheel, MS 27	185677	Terminal, Receptacle Type 36,37	186052	Spacer, .183" Thk 19
184951	Typewheel, MZ 27	185680	Plate, Identification 37	186053	Nut, Speed 19
184952	Typewheel, NA 27	185700	Base 34	186070	Typewheel, PS 29
184953	Typewheel, NB 27	185708	Screw, 8-32 x 3/8 Hex 35	186175	Bracket 6
184954	Typewheel, HC 28	185721	Bracket, Fuse 37	186213	Hub 16
184955	Typewheel, ND 28	185730	Modification Kit 37	186214	Washer, Spl 16
184956	Typewheel, NE 28	185731	Jumper, 3-3/4" Black 37	186240	Set of Parts 16
184957	Typewheel, NF 28	185732	Bracket, Fuse 37	186247	Shaft 11
184958	Typewheel, NG 28	185733	Insulator 36,37	186248	Shaft 12
184959	Typewheel, NH 28	185734	Fuse, SL-BL 2-1/4 Amp 37	186249	Cam, Selector 18
184960	Typewheel, NK 28	185736	Bracket, Spring 10	186253	Lever w/Hub 20
184961	Typewheel, NL 28	185775	Extension, Armature 21, 22,32	186254	Lever, Cam Follower 20,33
184962	Typewheel, NM 28	185788	Arm 26	186257	Clamp 20
184963	Typewheel, NP 28	185789	Stud 26	186259	Clamp, Bearing 16
184964	Typewheel, NR 28	185790	Plate, Detent 26	186261	Link 33
184965	Typewheel, NS 28	185791	Modification Kit 1,26	186262	Shaft, Trip Pivot 20,22
184966	Typewheel, NT 28	185796	Bracket 2	186264	Lever w/Stud 33
184967	Typewheel, NU 28	185799	Shaft 6	186265	Buffer 20
184968	Typewheel, NV 28	185816	Screw, 6-40 x 5/16 Spl 2	186268	Shaft, Distributor 19
184969	Typewheel, NW 28	185834	Plate, Identification 37	186271	Shaft, Distributor 19
184970	Typewheel, NX 28	185871	Screw w/Lockwasher, 8-32 x 3/8 Hex 34	186313	Lever 24
184971	Typewheel, NY 28	185877	Platen 2,26	186401	Clutch Assembly 18
184972	Typewheel, NZ 28	185945	Insulator 5	186412	Arm 16
184973	Typewheel, PA 28	185968	Latch 26	186413	Arm 16
184974	Typewheel, PB 28	185969	Hub 26	186432	Guideplate 7
184975	Typewheel, PC 28	185970	Lever w/Post 26	186442	Piston 9
184976	Typewheel, PD 28	185971	Modification Kit 1,26	186443	Bumper 9
184977	Typewheel, PE 29	185975	Guidepost 6	186445	Cover, Contact 17
184978	Typewheel, PF 29	185980	Retainer 32	186446	Lever, Blocking 17
184979	Typewheel, PG 29	185984	Lever 24	186447	Lever, Blocking 17
184980	Typewheel, PH 29	185985	Lever 24	186448	Timer Assembly 36
184981	Typewheel, PJ 29	185986	Post 8,26	186460	Pinion, 19T 35
184982	Typewheel, PL 29	185987	Roller 8,26	186462	Pulley w/64T Gear, 13T 35
184983	Typewheel, PM 29	185989	Collar 4	186465	Timer Assembly 36
184984	Typewheel, PN 29	185990	Platen 4	186468	Lever 24
184985	Typewheel, PR 29	185993	Arm, Latch 31	186536	Set of Parts 9
184986	Typewheel, PT 29	185994	Arm w/Hub 31	186538	Pulley w/52T Gear 35
184987	Typewheel, PW 29	185996	Spacer 31	186539	Gear 35
184988	Typewheel, PX 29	185997	Plate, Stop 31	186555	Timer, Elapsed 36
184989	Typewheel, PY 29	185998	Plate 31	186556	Timer Assembly, Elapsed 36
184990	Typewheel, PZ 29	185999	Arm, Stop 31	186557	Bracket 15
184991	Typewheel, RA 29	186009	Insulator 36	186575	Arm 11,12,16
184993	Typewheel, RC 29	186010	Bracket 36	186576	Arm 16
184994	Typewheel, RD 29			186583	Plate 36
184996	Typewheel, RF 29			186584	Timer Assembly 36
184998	Typewheel, RH 29			186585	Timer Assembly 36
184999	Typewheel, RJ 29			186606	Set of Parts 4

NUMERICAL INDEX (Continued)

Part Number	Description and Page Number	Part Number	Description and Page Number	Part Number	Description and Page Number
186608	Lever 25	186731	Ring, Compression 13	197464	Diode 15
186609	Lever 25	186734	Insulator 17	198670	Screw w/Lockwasher, 6-40 x 5/16 Hex 2,3,4,5,10
186610	Lever 25	186738	Insulator 34	199440	Screw, 5-40 x 4/8 Fil 11, 12
186611	Lever 25	186747	Bracket 30	315756	Plate, Identification 35
186639	Sleeve, 7/16 ID x 1-1/2" Lg Insulating 37	186748	Spacer 30	320246	Fuse, SL-BL 1.8 Amp 37
186642	Knob 18	186778	Screw, 6-40 x 7/32 Hex 18	320410	Terminal, Spade Type 36
186664	Post 33	186796	Lever, Function 24	320411	Terminal, Spade Type 33
186665	Set of Parts 2	192007	Terminal, Tab Type 37	320423	Plate 36
186669	Spring 3,18,24,25	194956	Spring 12	323094	Diode 36
186691	Insert 34	194987	Screw, 8-32 x 3/8 Hex 5, 16	324499	Terminal 36,37
186695	Link 7	195614	Pin, Key 37	327323	Ring, Retaining 16
186696	Link w/Stud 7	196932	Sleeve, 7/16 ID x 1-1/4" Lg Insulating 37		
186697	Set of Parts 7				

33 CALL CONTROL UNIT (UCC)

PARTS

FIGURE	CONTENTS	PAGE
1	Base Plate Components for use with Rotary Dial	2
2	Base Plate Components for use with Touch-Tone or Card Dialing	3
3	Electrical Components for use with Rotary Dial	4
4	Electrical Components for use with Rotary Dial (Continued)	5
5	Electrical Components for use with Touch-Tone or Card Dialing	6
6	Base Plate and Electrical Components for DC Signal Private Line	7
7	Electrical Components for Computer Control Private Line	8
8	Base Plate and Electrical Components for use with Station Controller	9
9	Base Plate and Electrical Components for use with Station Controller (Continued)	10
10	Base Plate and Electrical Components	11
11	Base Plate and Electrical Components (Continued)	12
12	186627 Set Interface Logic Assembly	13
13	186630 Modification Kit to Provide Break Detection and Indication	14
14	Alarms and Speaker	15
15	181815, 182695, 183985, 184012, 186000 and 332709 Selector Magnet Driver Assemblies	16
16	Receive-Only Bracket Components	17
17	182489, 193487, 186600 and 186601 Dial Modifications (Continued)	18
18	186602, 186603, 193488 and 195927 Dial Modifications	19
19	193486, 193489, 195924, 195926 and 327420 Dial Modifications (Continued)	20
20	Key Assemblies	21
21	Power Cords and Jumpers	22
22	Cable Components	23
23	186670 Modification Kit to Provide Private Line Numerical Index	24 25

**Denotes a painted part.
HF-Light Olive Gray Smooth Vinyl

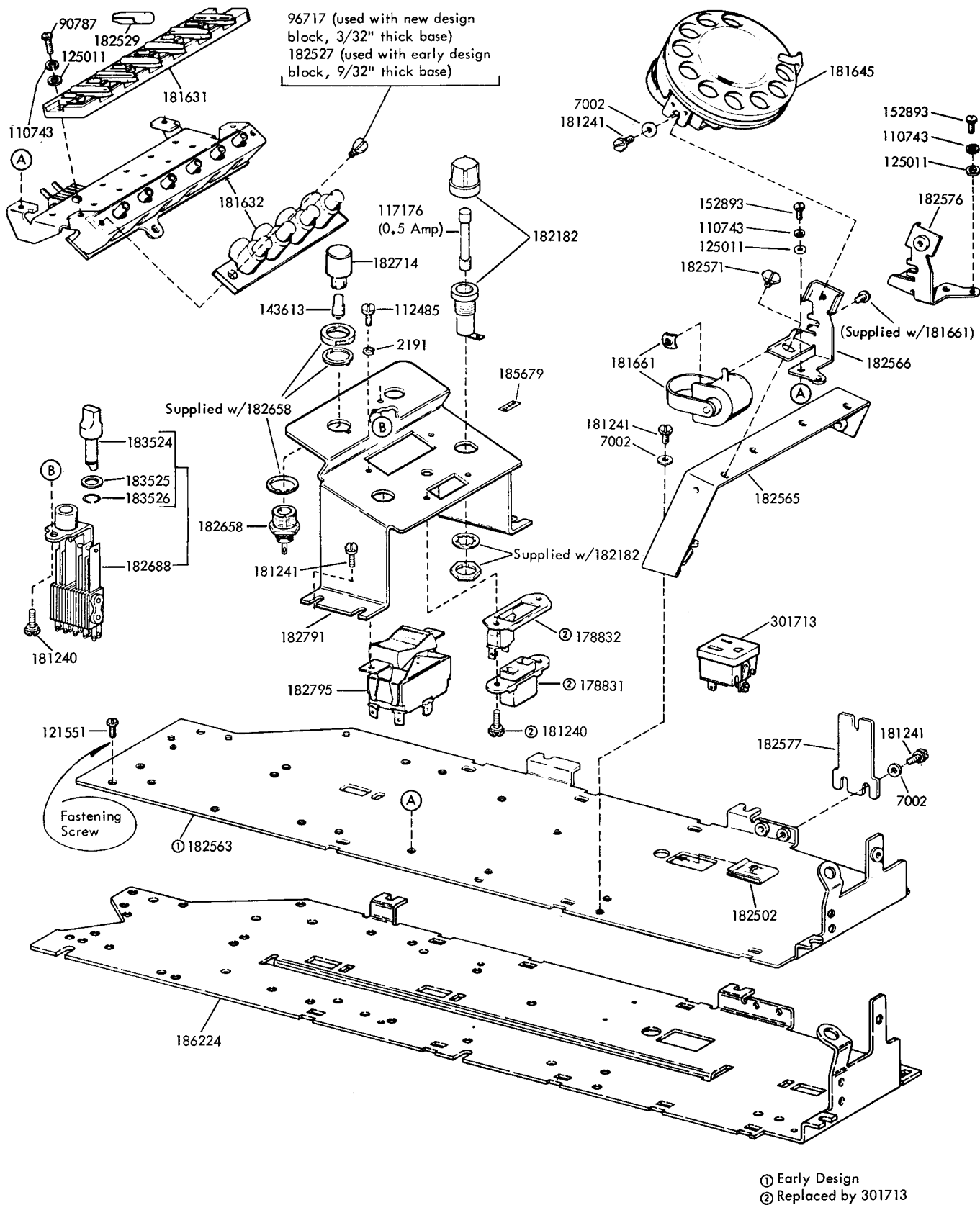

FIGURE 1. BASE PLATE COMPONENTS FOR USE WITH ROTARY DIAL

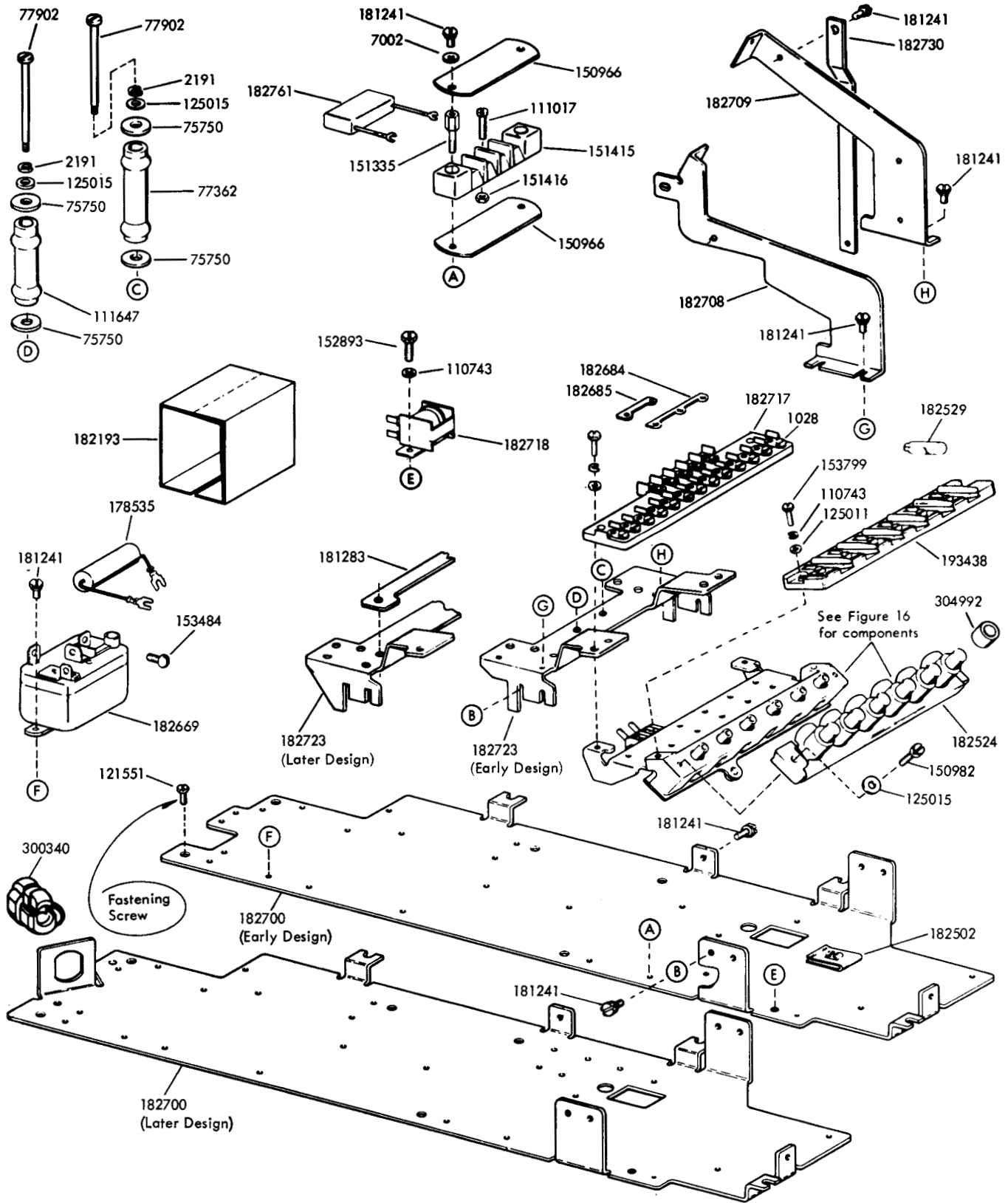

FIGURE 2. BASE PLATE COMPONENTS FOR USE WITH TOUCH-TONE OR CARD DIALING

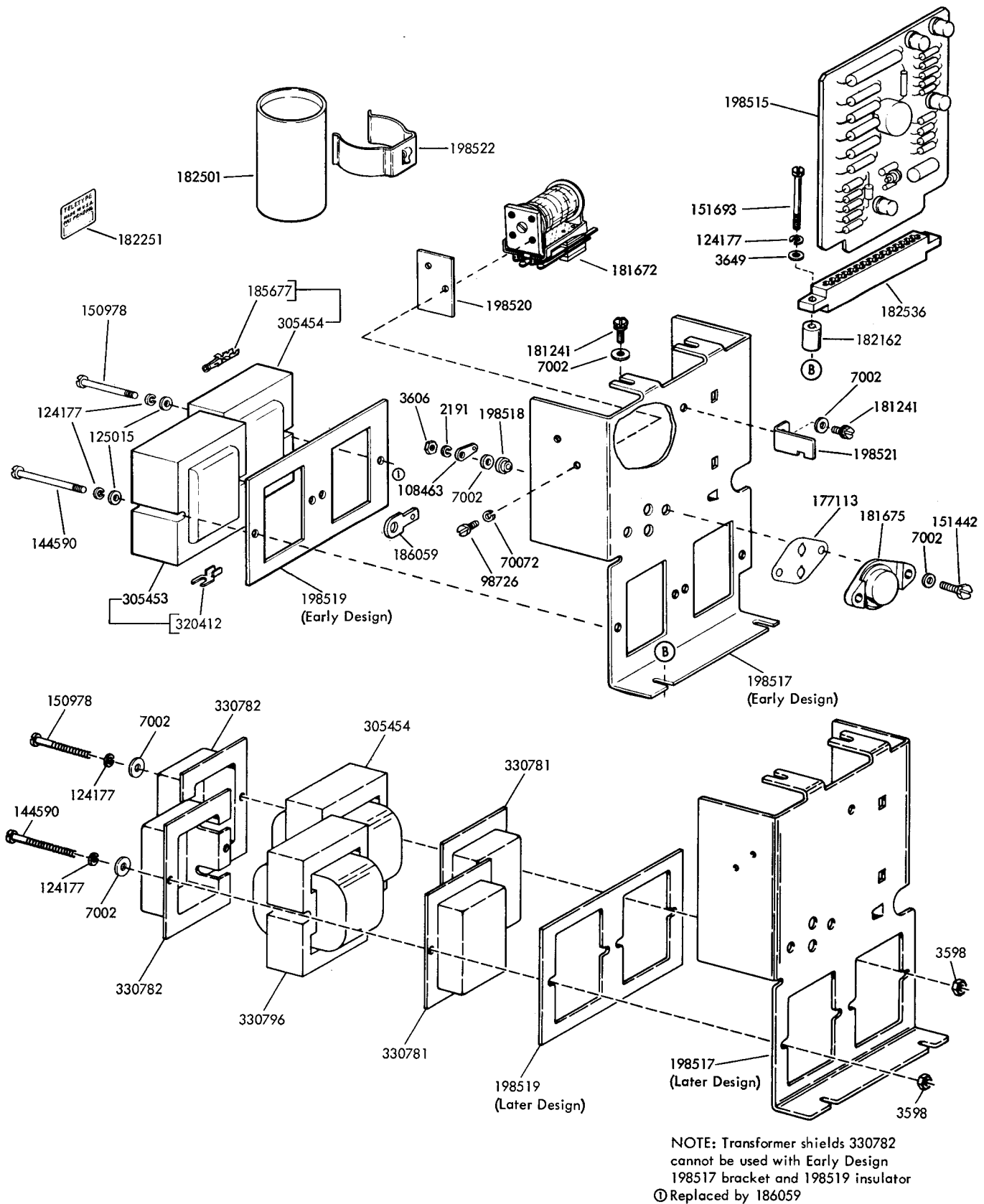

FIGURE 3. ELECTRICAL COMPONENTS FOR USE WITH ROTARY DIAL

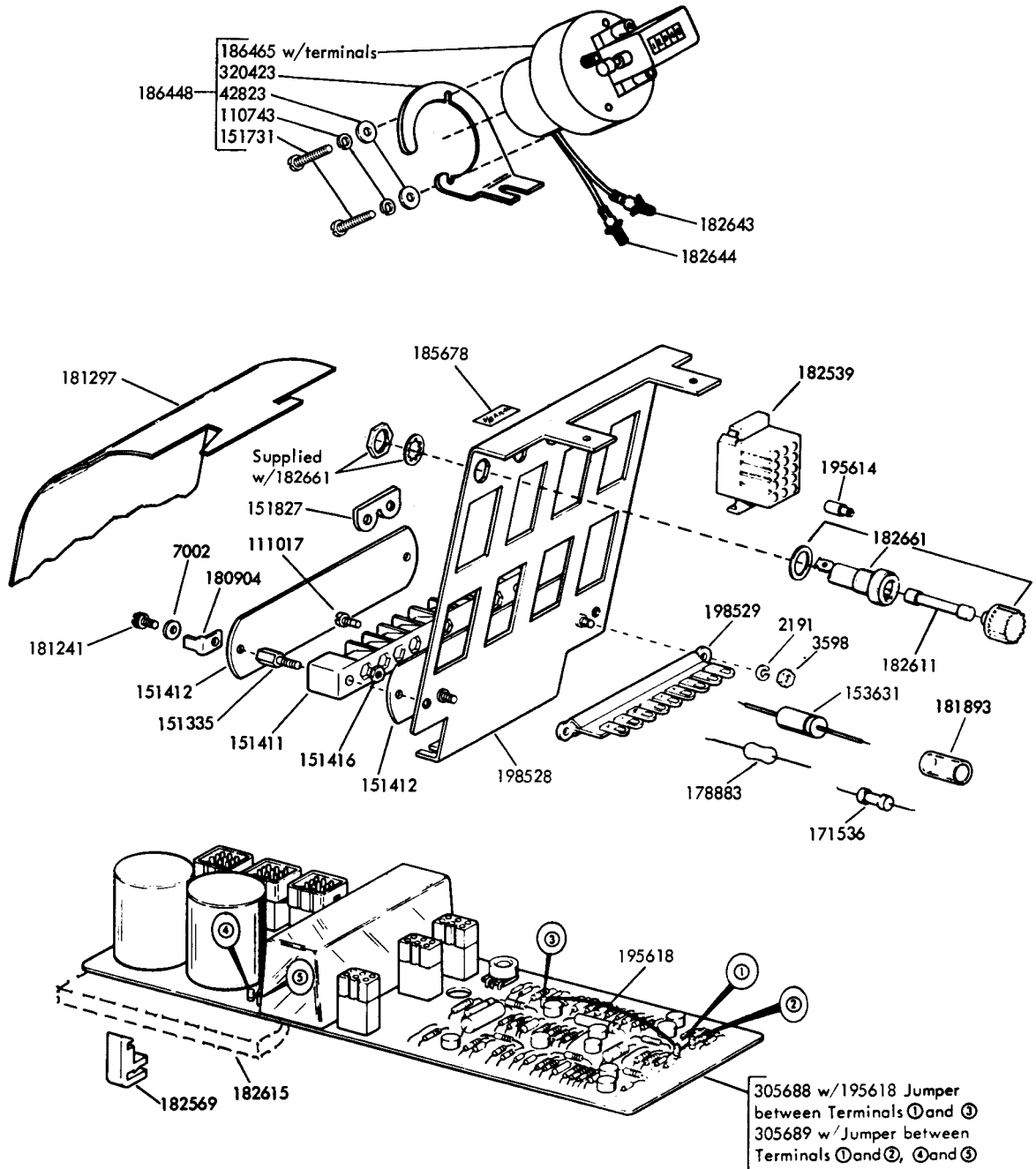

FIGURE 4. ELECTRICAL COMPONENTS FOR USE WITH ROTARY DIAL (Continued)

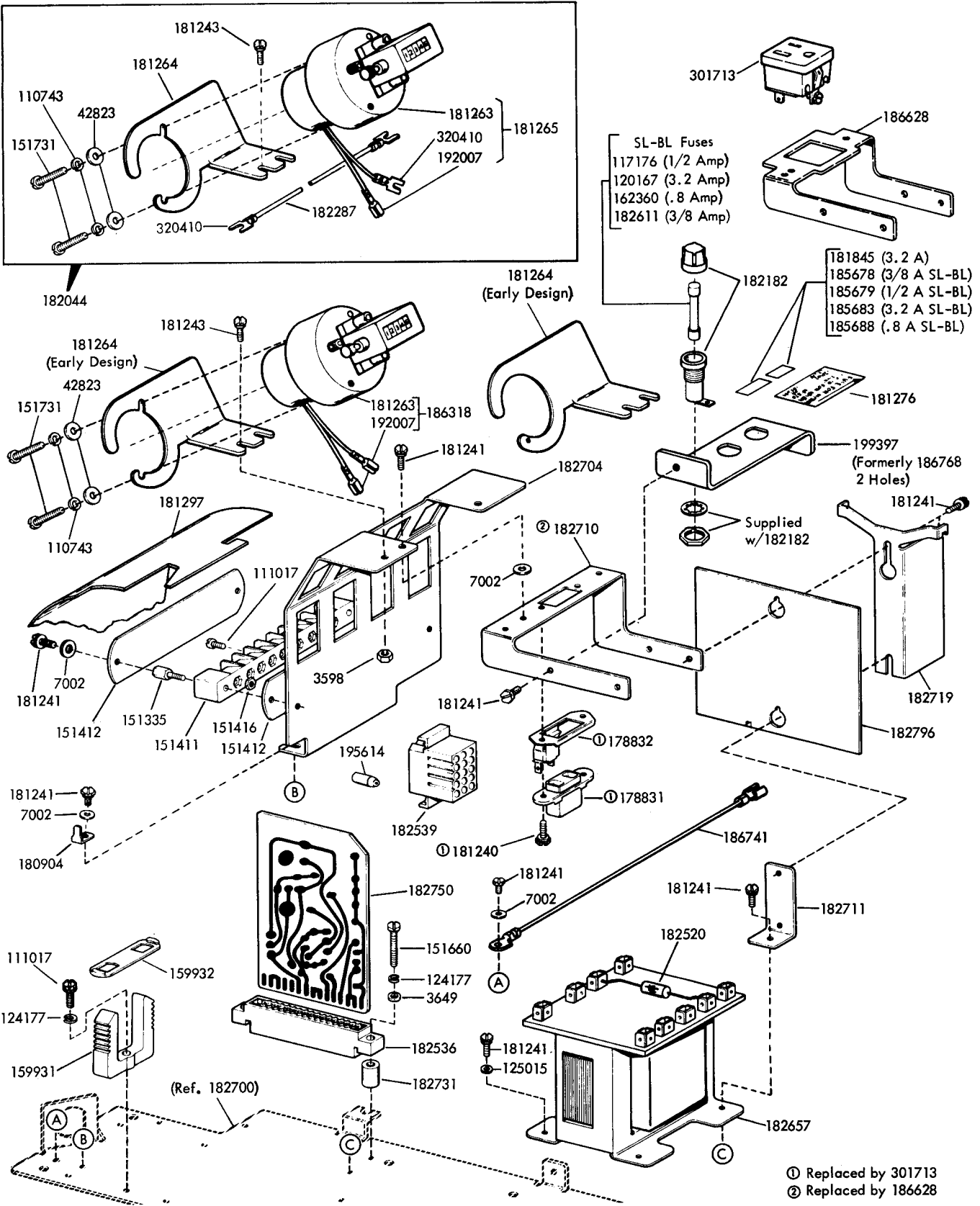

FIGURE 5. ELECTRICAL COMPONENTS FOR USE WITH TOUCH-TONE OR CARD DIALING

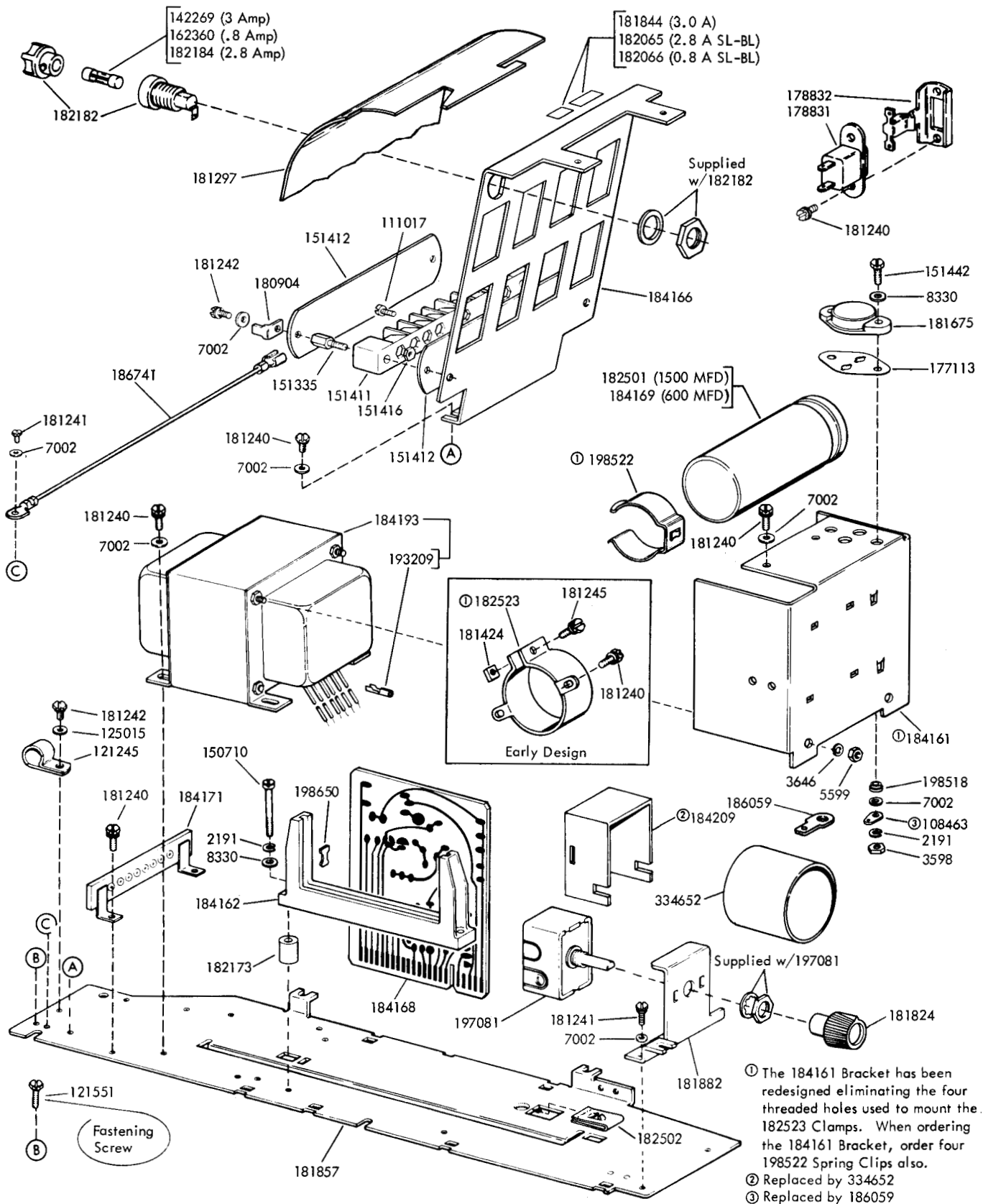

FIGURE 7. ELECTRICAL COMPONENTS FOR COMPUTER CONTROL PRIVATE LINE

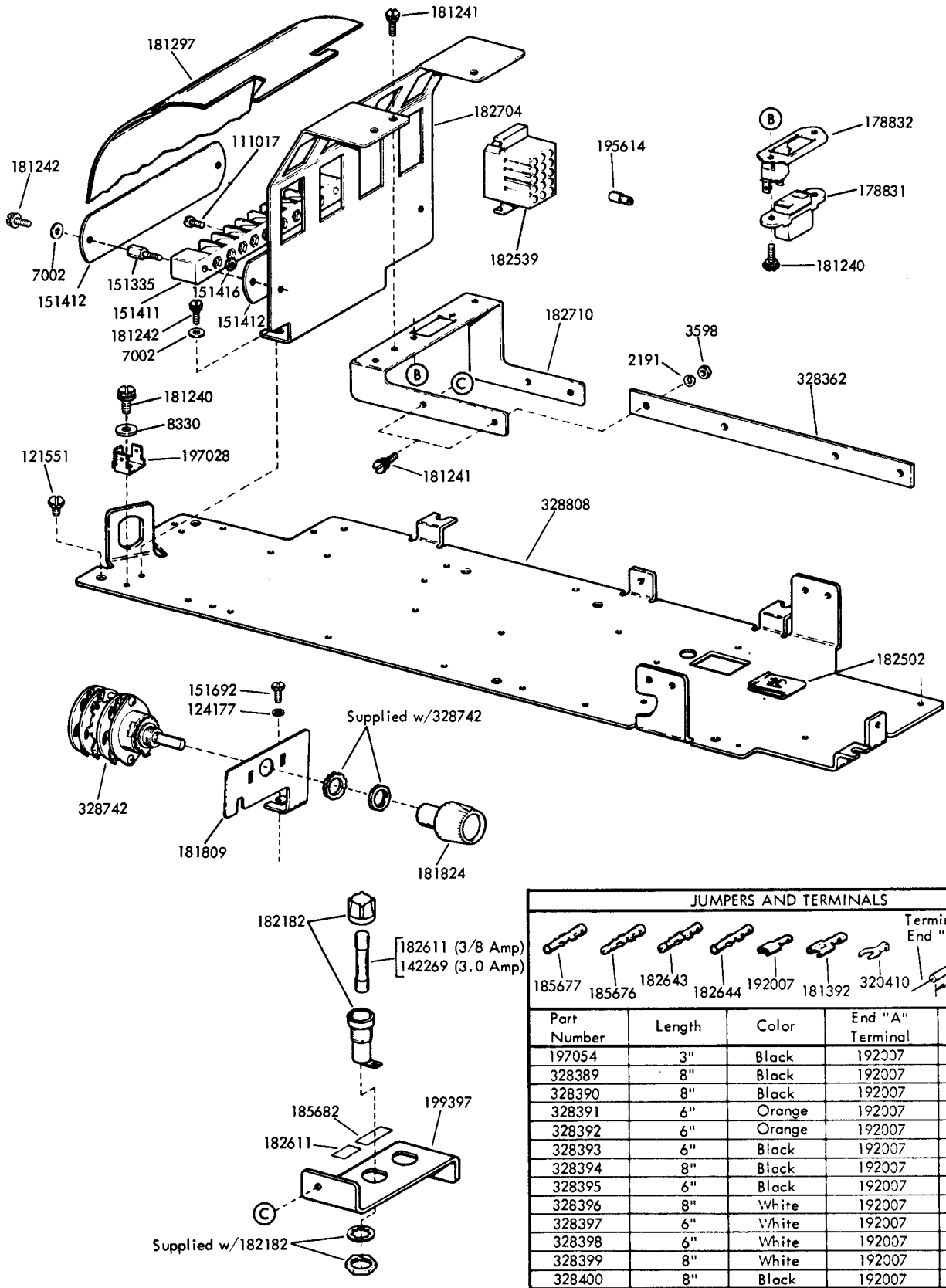

FIGURE 8. BASE PLATE AND ELECTRICAL COMPONENTS FOR USE WITH STATION CONTROLLERS

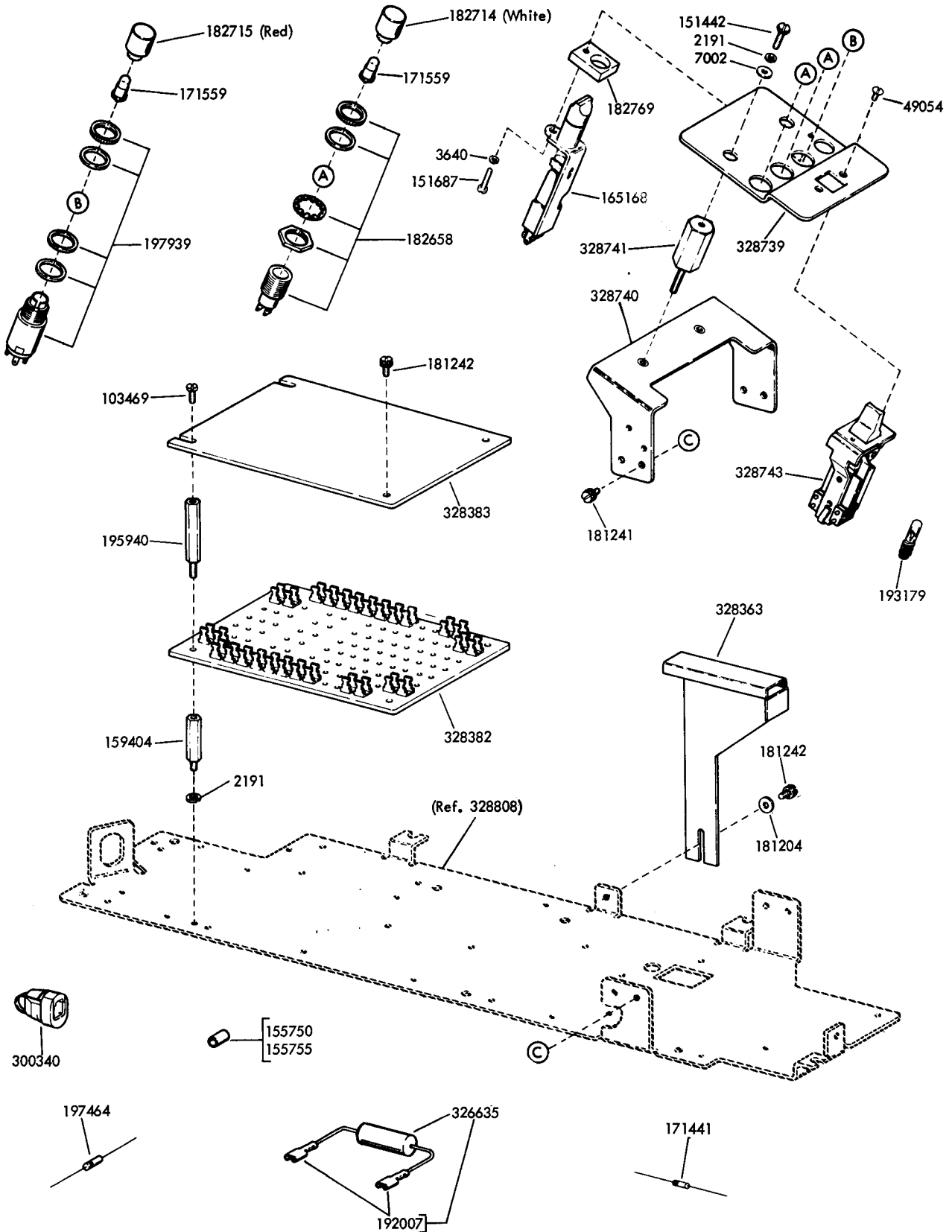

FIGURE 9. BASE PLATE AND ELECTRICAL COMPONENTS FOR USE WITH STATION CONTROLLER (Continued)

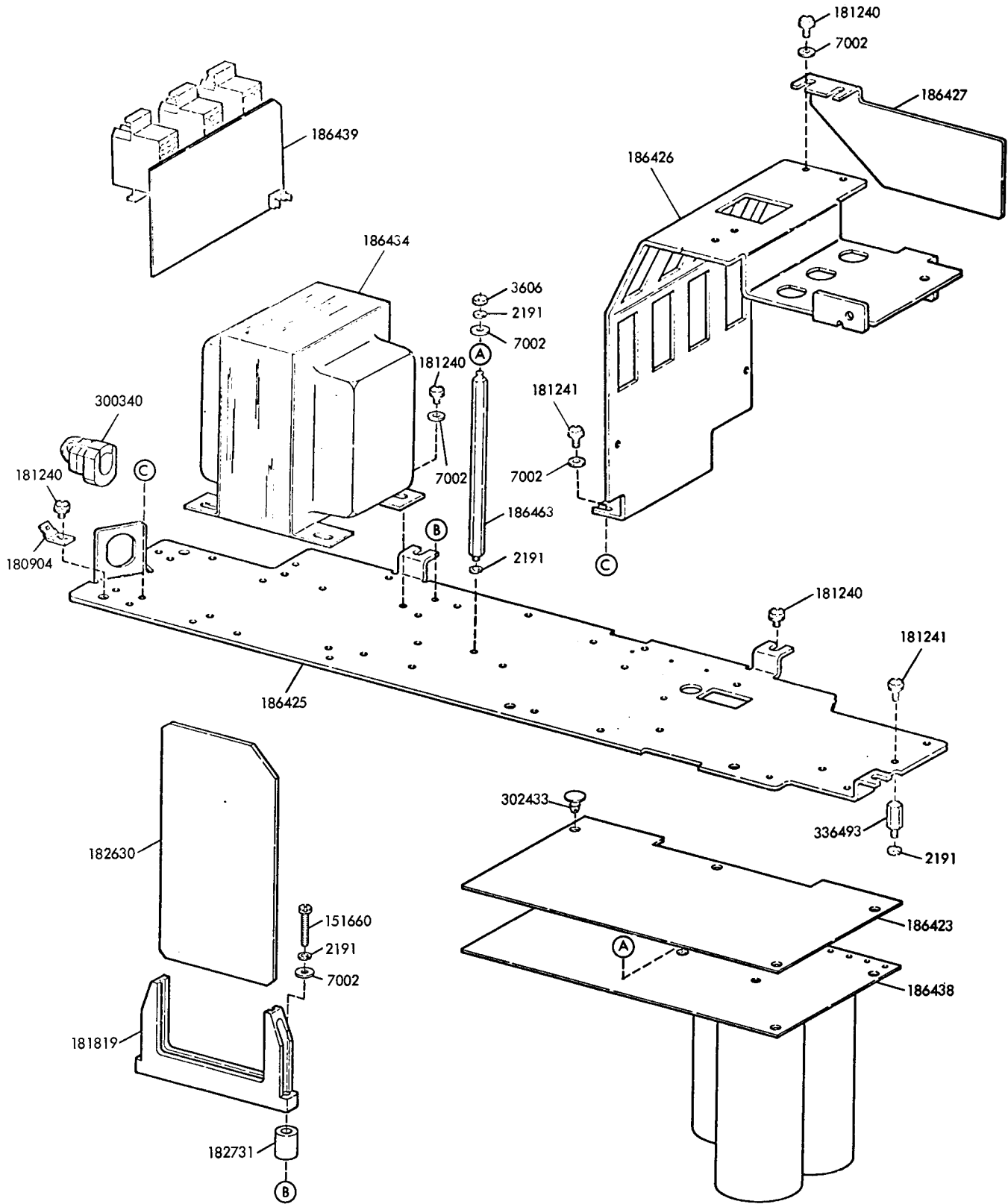

FIGURE 10. BASE PLATE AND ELECTRICAL COMPONENTS

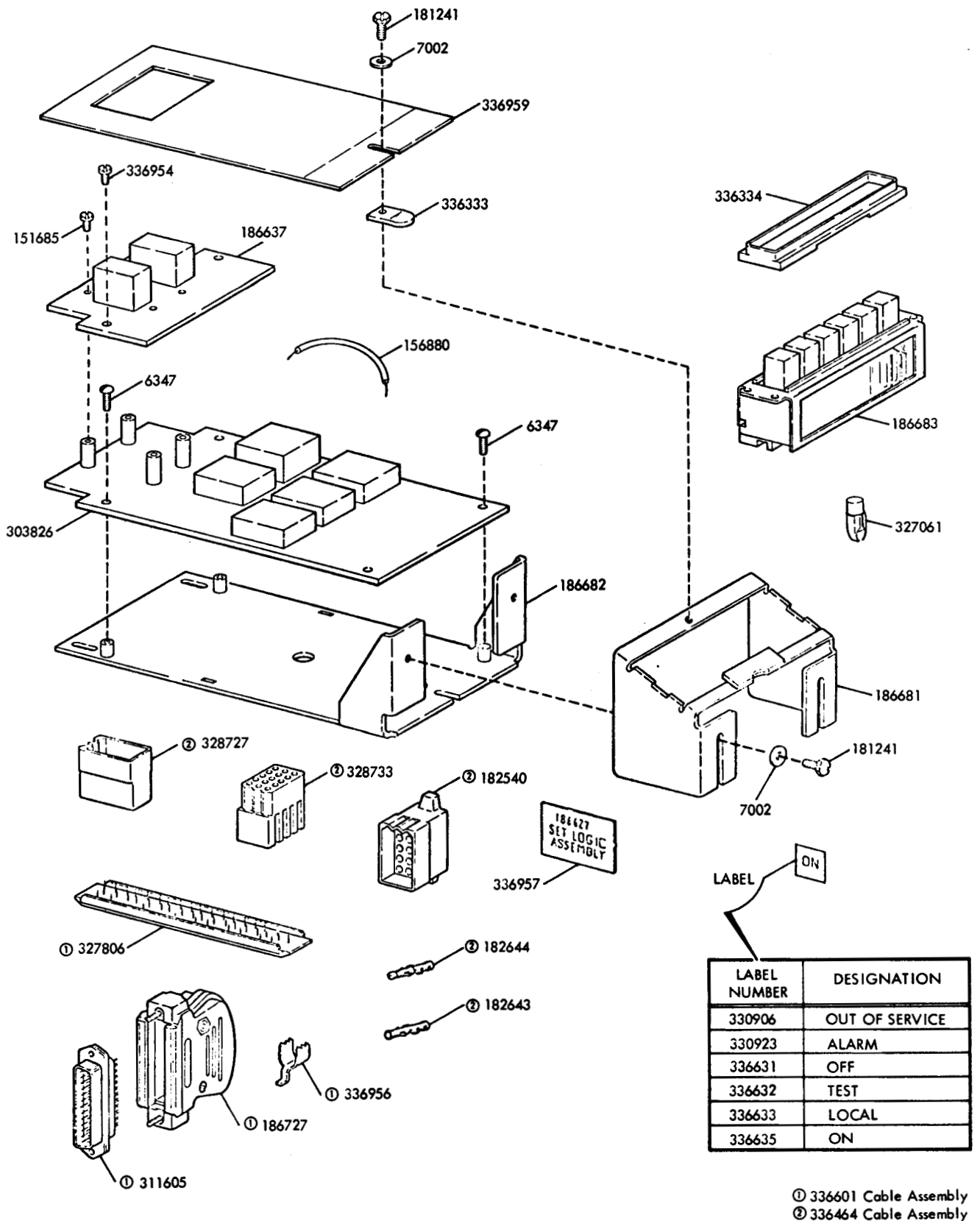
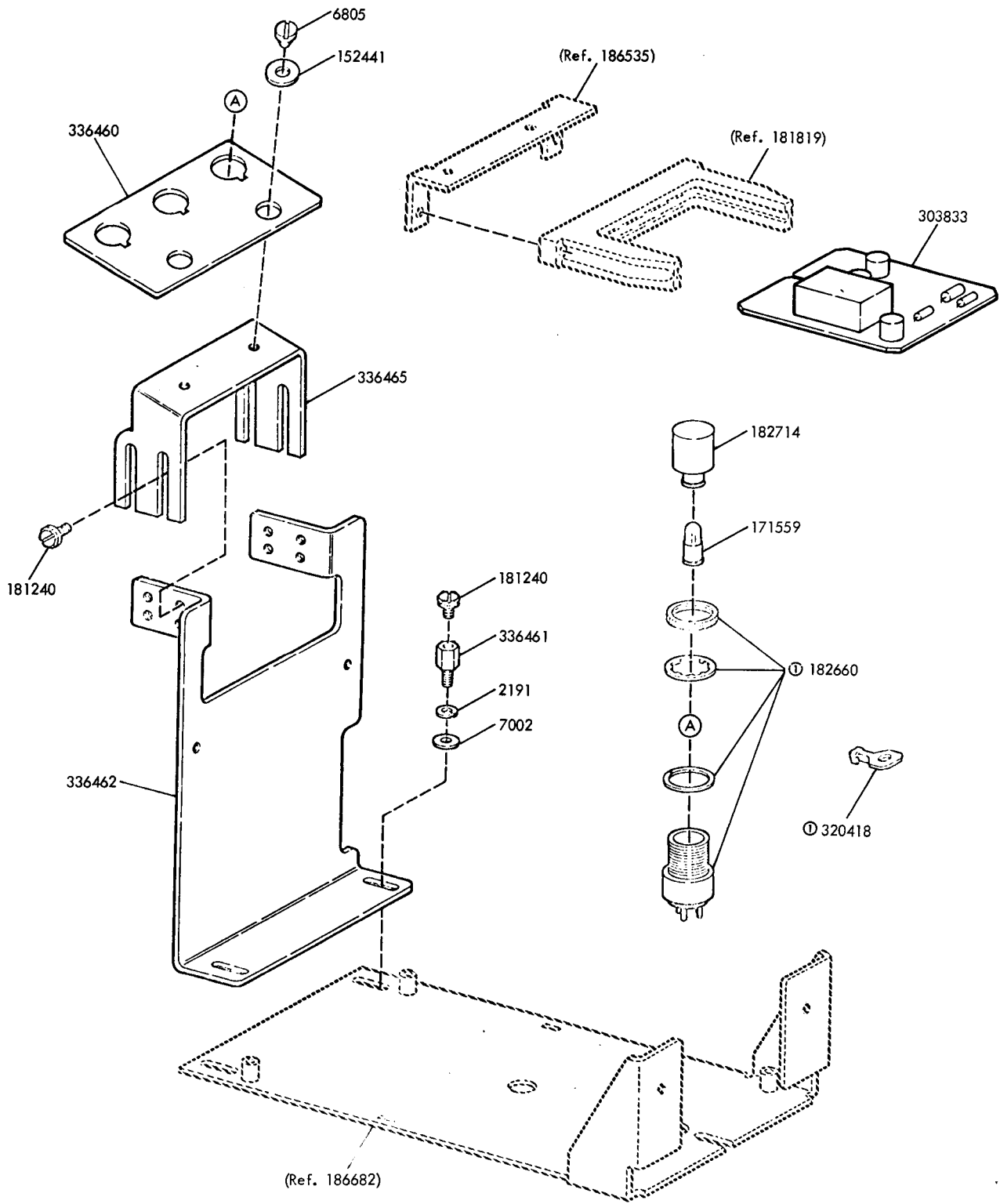

FIGURE 12. 186627 SET INTERFACE LOGIC ASSEMBLY



ⓐ 336471 Cable Assembly

FIGURE 13 186630 MODIFICATION KIT TO PROVIDE BREAK DETECTION AND INDICATION

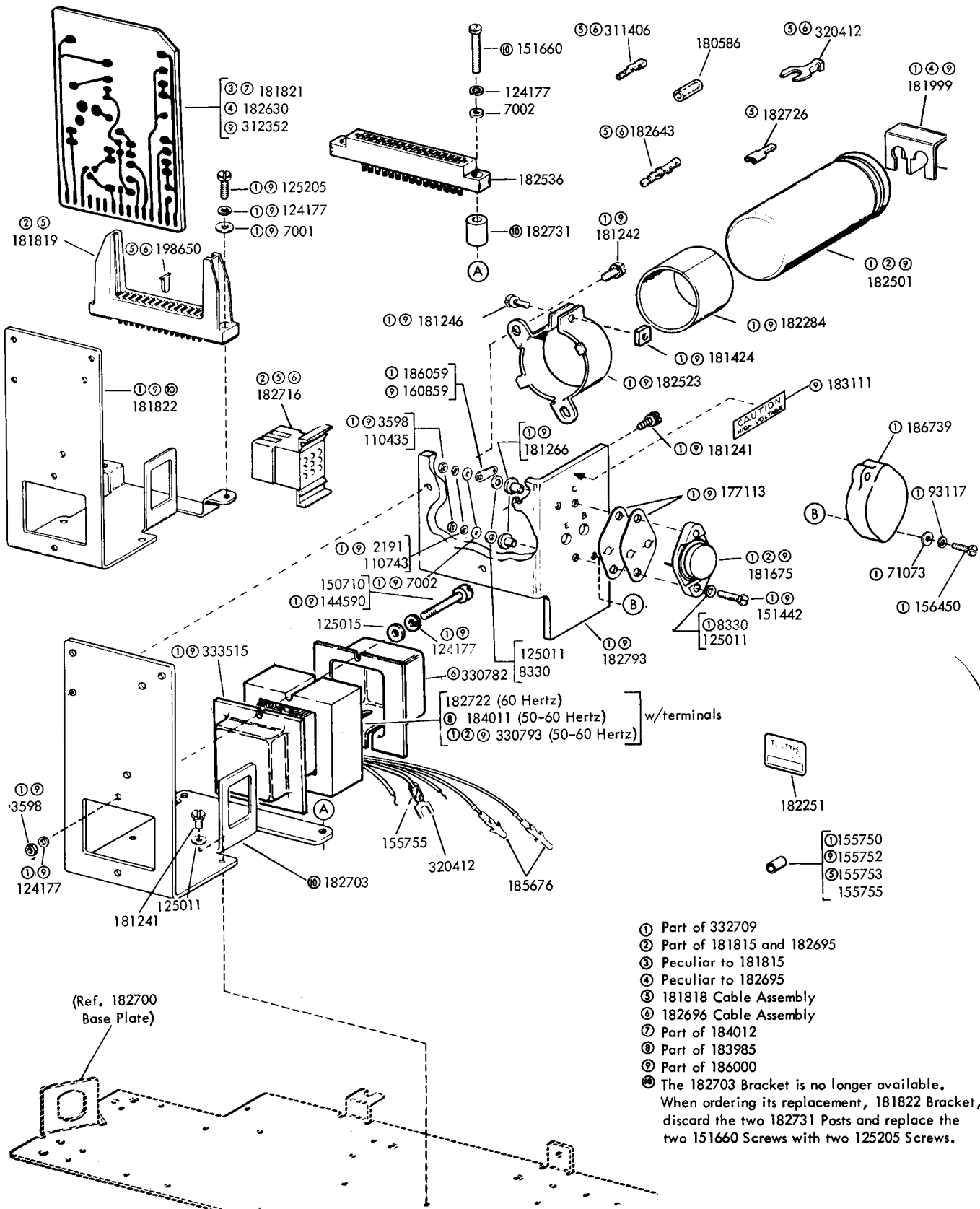
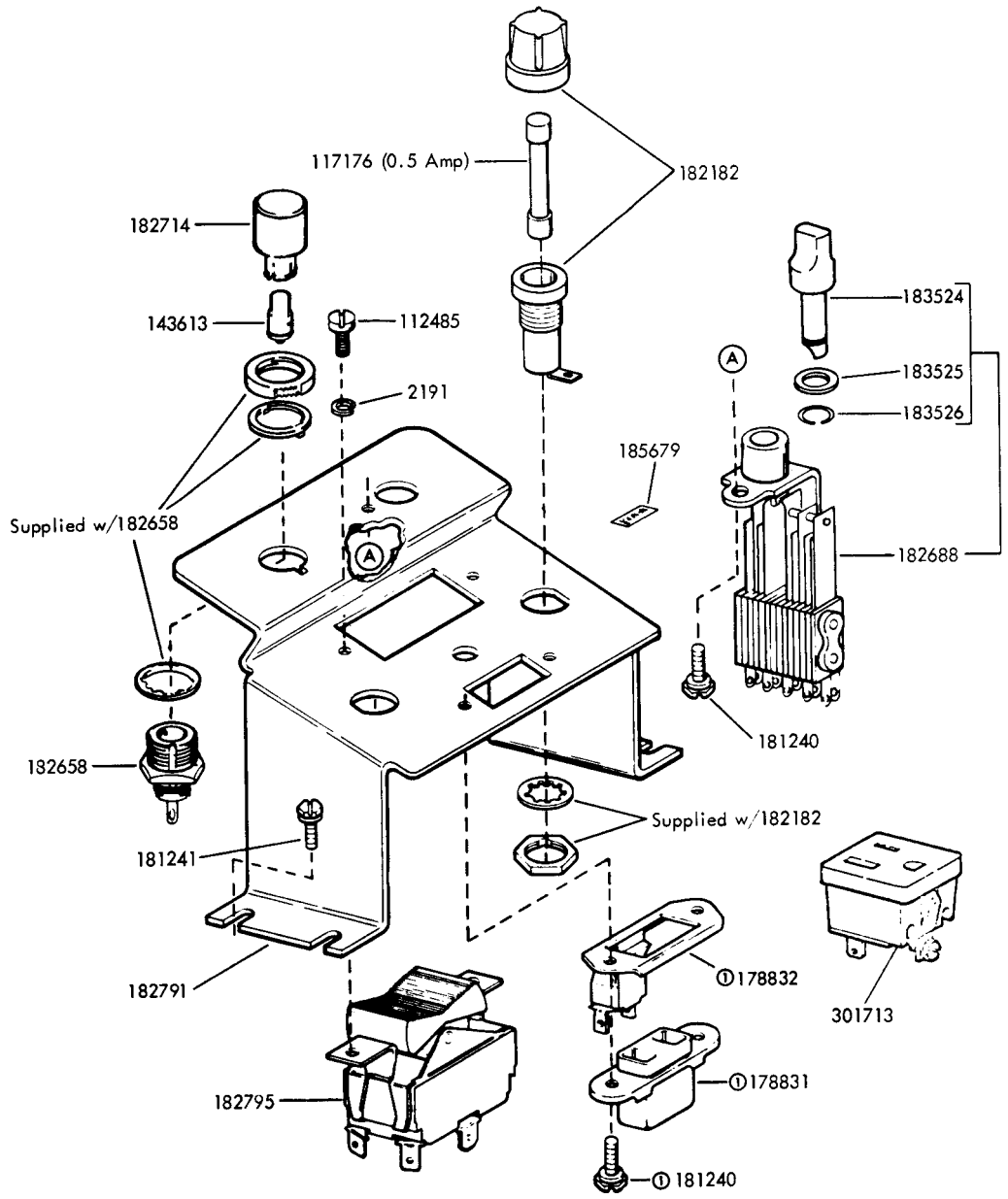

FIGURE 15. 181815, 182695, 183985, 184012, 186000 and 332709 SELECTOR MAGNET DRIVER ASSEMBLIES

- ① Part of 332709
- ② Part of 181815 and 182695
- ③ Peculiar to 181815
- ④ Peculiar to 182695
- ⑤ 181818 Cable Assembly
- ⑥ 182696 Cable Assembly
- ⑦ Part of 184012
- ⑧ Part of 183985
- ⑨ Part of 186000
- Ⓜ The 182703 Bracket is no longer available. When ordering its replacement, 181822 Bracket, discard the two 182731 Posts and replace the two 151660 Screws with two 125205 Screws.



ⓐ Replaced by 301713

FIGURE 16. RECEIVE-ONLY BRACKET COMPONENTS

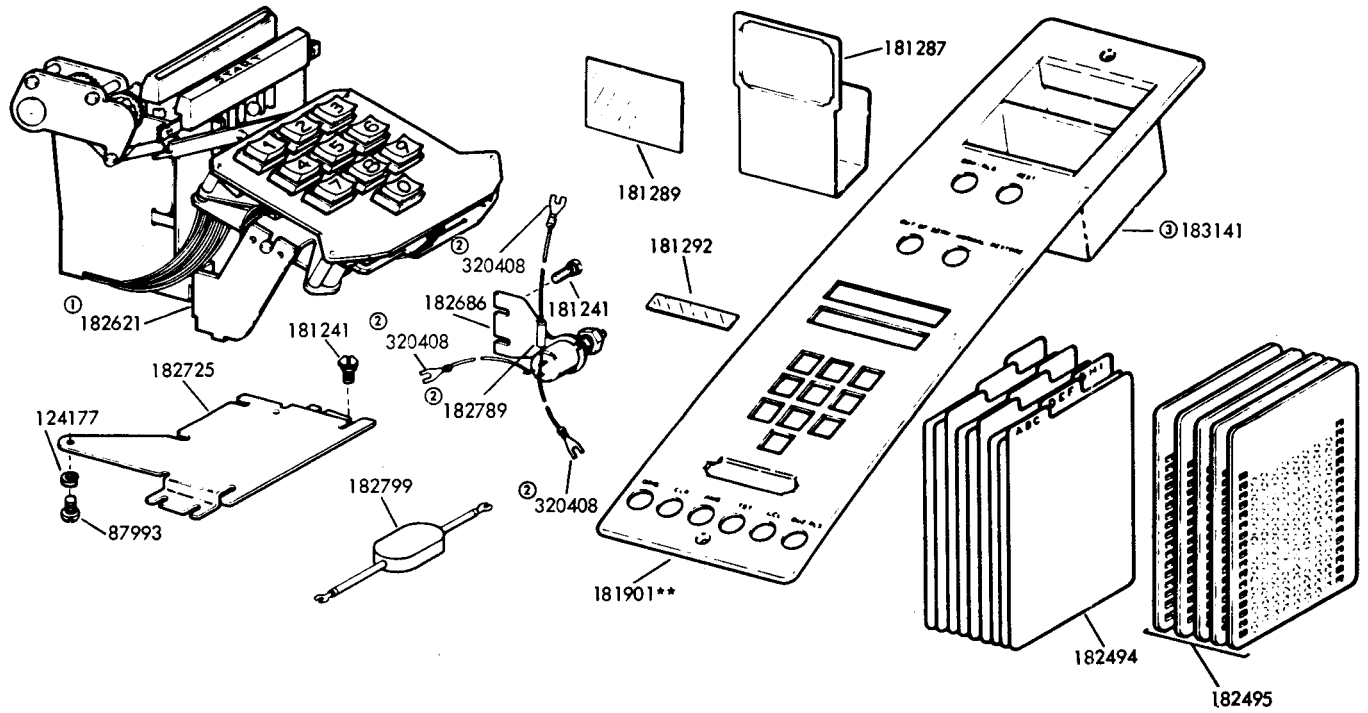

Manual 10-button
TOUCH-TONE and Card Dial

Part of 195927 (less Dialer) and 193488 (with Dialer)
Modification Kits (Specification 501405)

- ① Peculiar to 193488
- ② Part of 182686
- ③ Supplied as part of faceplate or can be ordered separately

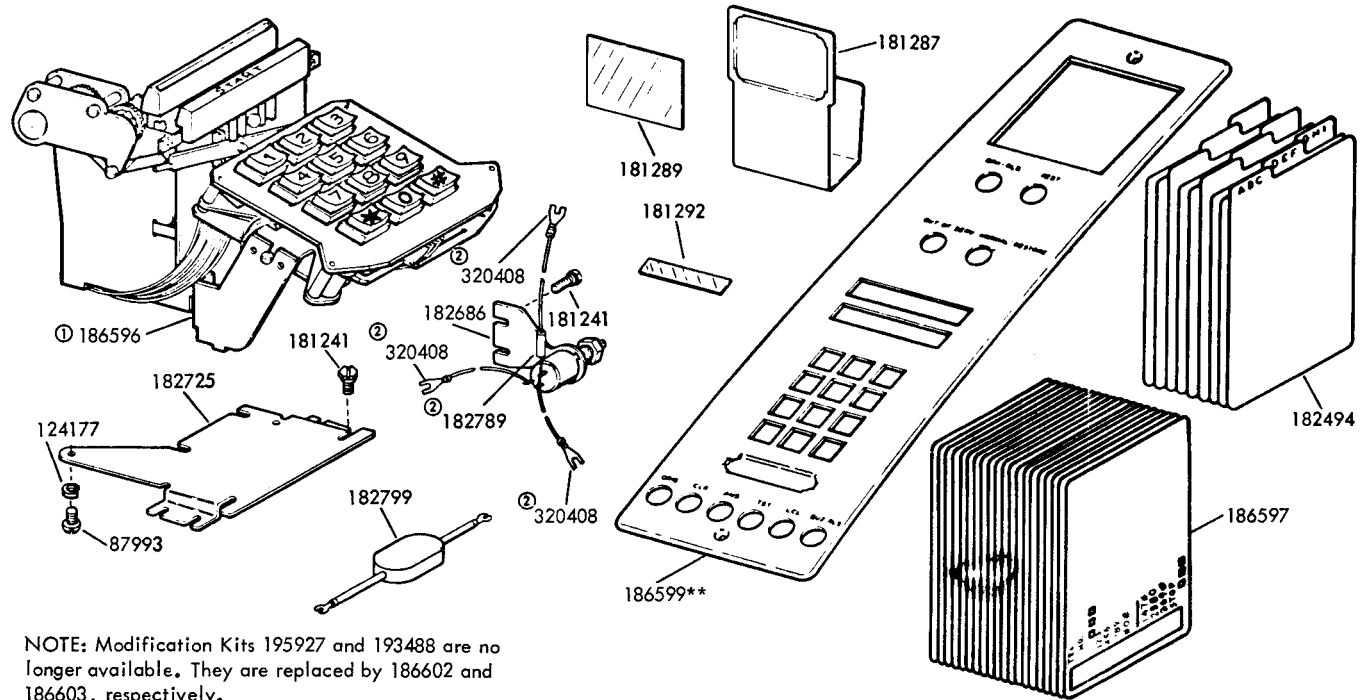

NOTE: Modification Kits 195927 and 193488 are no longer available. They are replaced by 186602 and 186603, respectively.

Manual 12-button
TOUCH-TONE and Card Dial

Part of 186602 (less Dialer) and 186603 (with Dialer)
Modification Kits (Specification 501405)

- ① Peculiar to 186603
- ② Part of 182686
- **Refer to page 1 for finish suffix

FIGURE 18. 186602, 186603, 193488 and 195927 DIAL MODIFICATIONS (Continued)

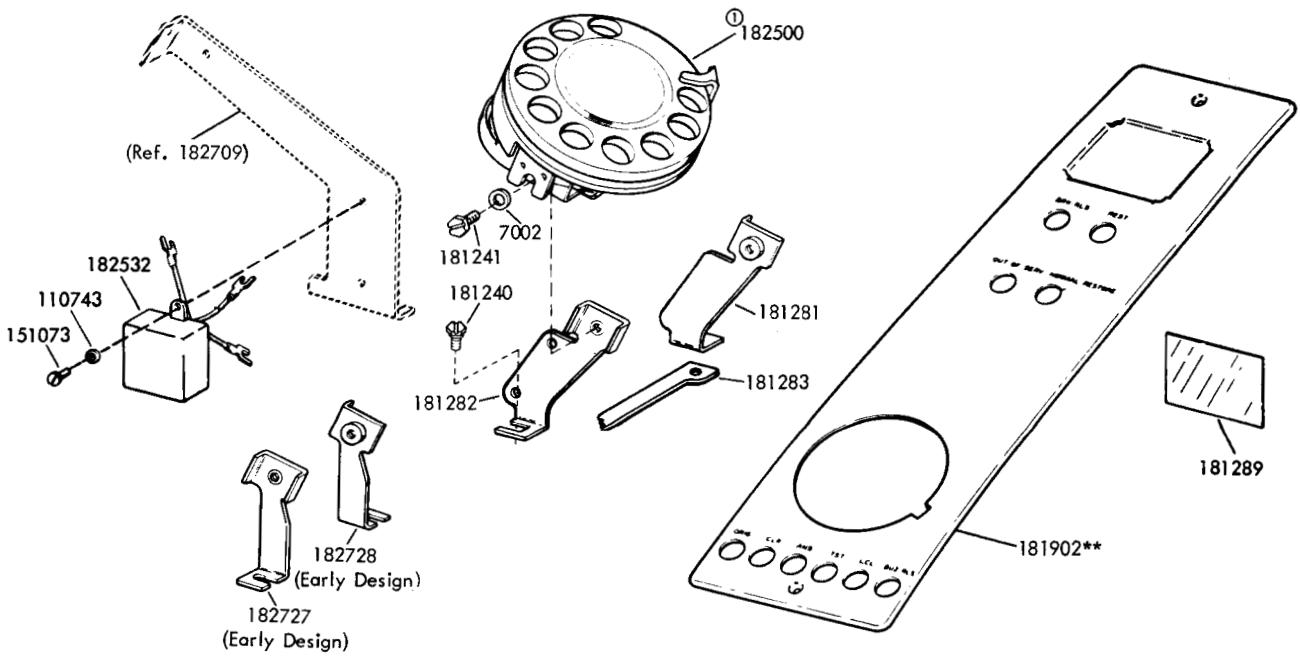

Rotary Dial Part of 193489 (with Dialer) and 195926 (less Dialer) Modification Kits (Specification 501565)

① Peculiar to 193489

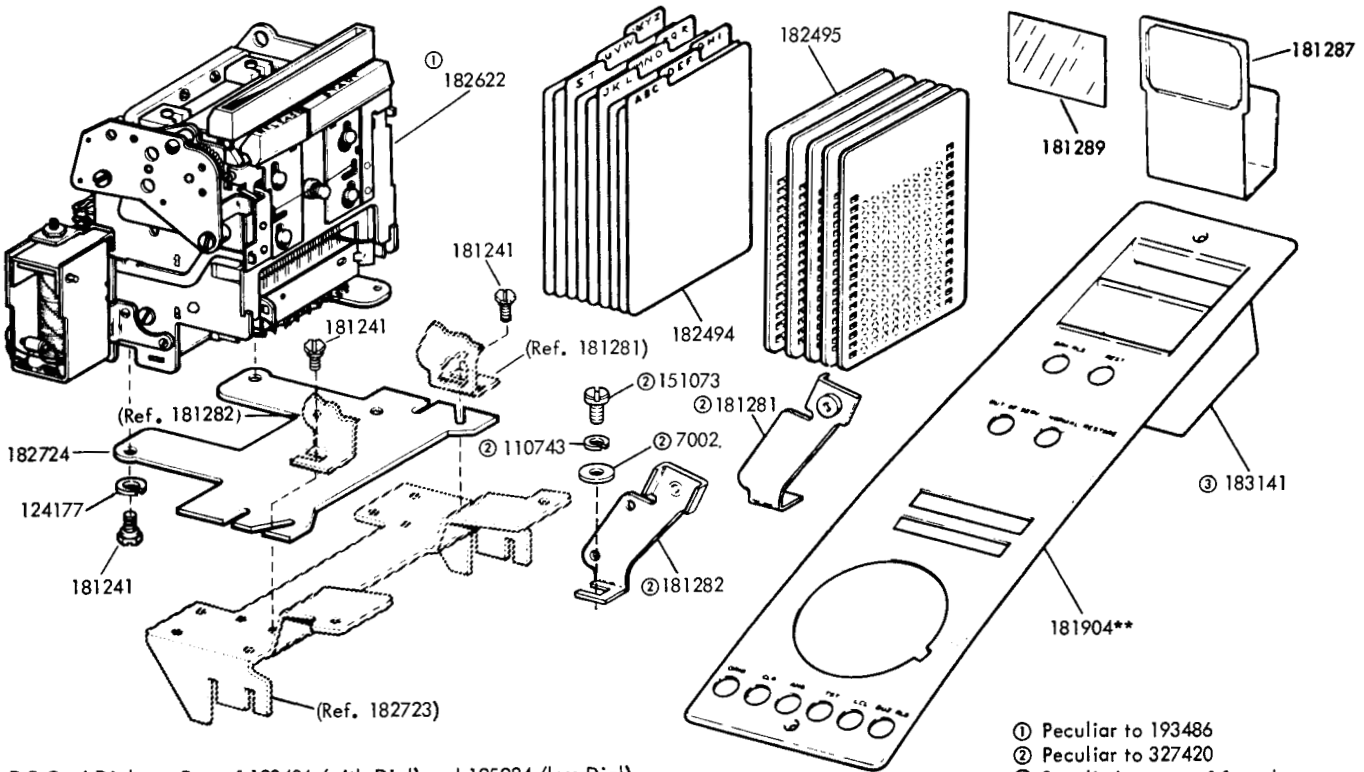

DC Card Dial Part of 193486 (with Dial) and 195924 (less Dial) Modification Kits (Specification 50164S) and 327420 (less Dial) Modification Kit (Specification 501565)

- ① Peculiar to 193486
- ② Peculiar to 327420
- ③ Supplied as part of faceplate or can be ordered separately
- ** Refer to page 1 for finish suffix

FIGURE 19. 193486, 193489, 195924, 195926 and 327420 DIAL MODIFICATIONS (Continued)

KEY ASSEMBLY PART LOCATION TABLE								
POSITION		182581	182582					182589
F	Plunger Switch		182559 182562					182559
E	Plunger Switch	182667 182562	182559 182561					182559 182562
D	Plunger Switch	182667 181638	182559 182562					182559 182562
C	Plunger Switch	182667	182559 182562					182559
B	Plunger Switch	182667 182562	182559 182562					182559
A	Plunger Switch		182559 182562					182559 182562
Plunger Spring								
		182554	182554					182554
			182556					182556
			182666					182666
			182535					182535
		181637	182557					182557

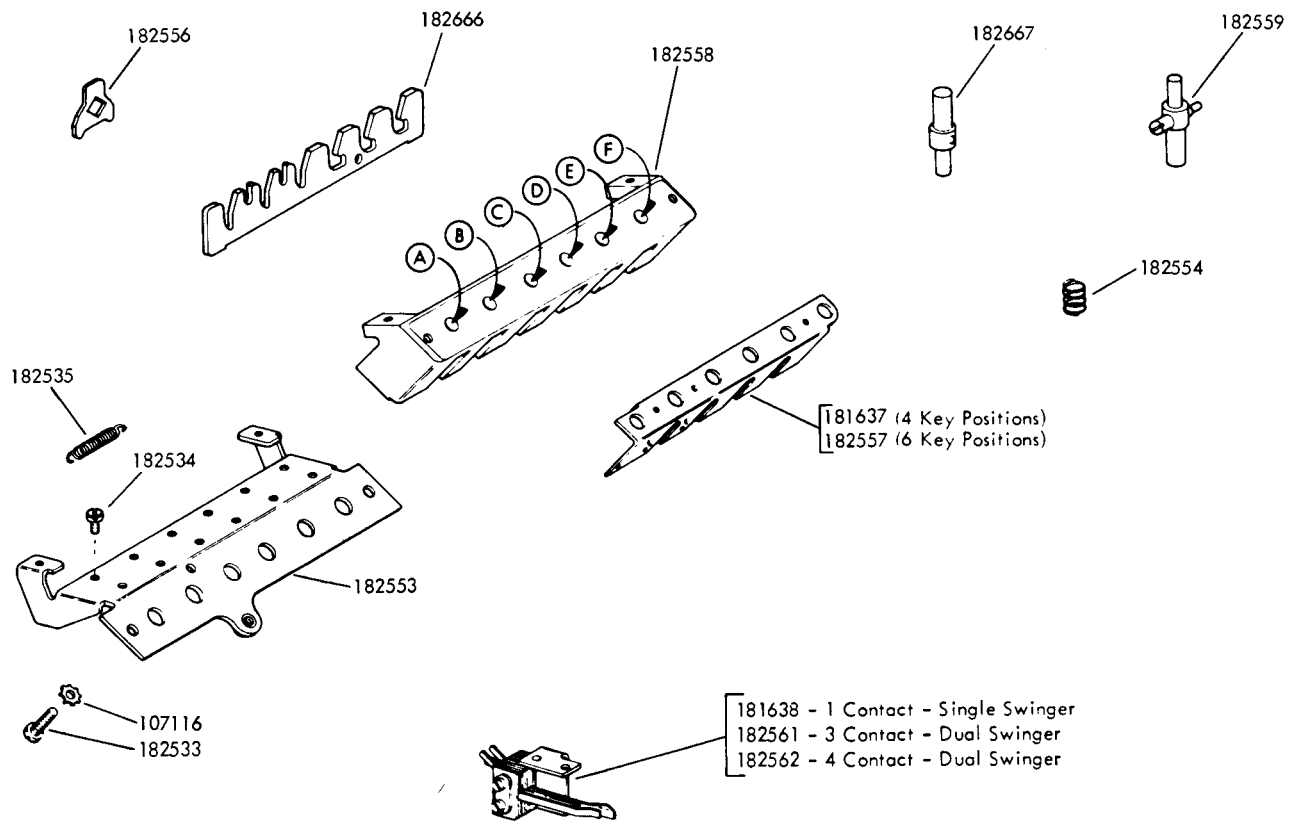

FIGURE 20. KEY ASSEMBLIES

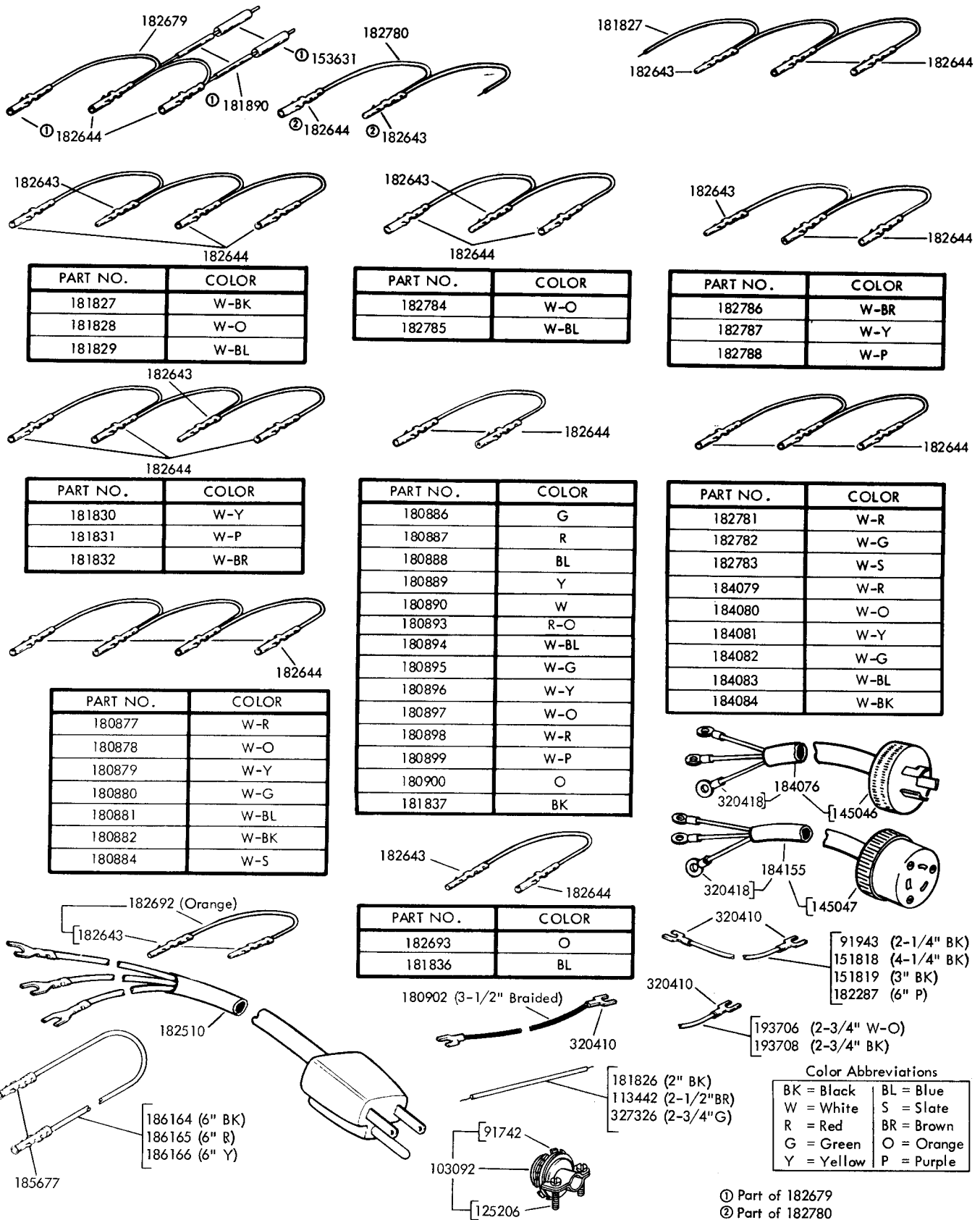

FIGURE 21. POWER CORDS AND JUMPERS

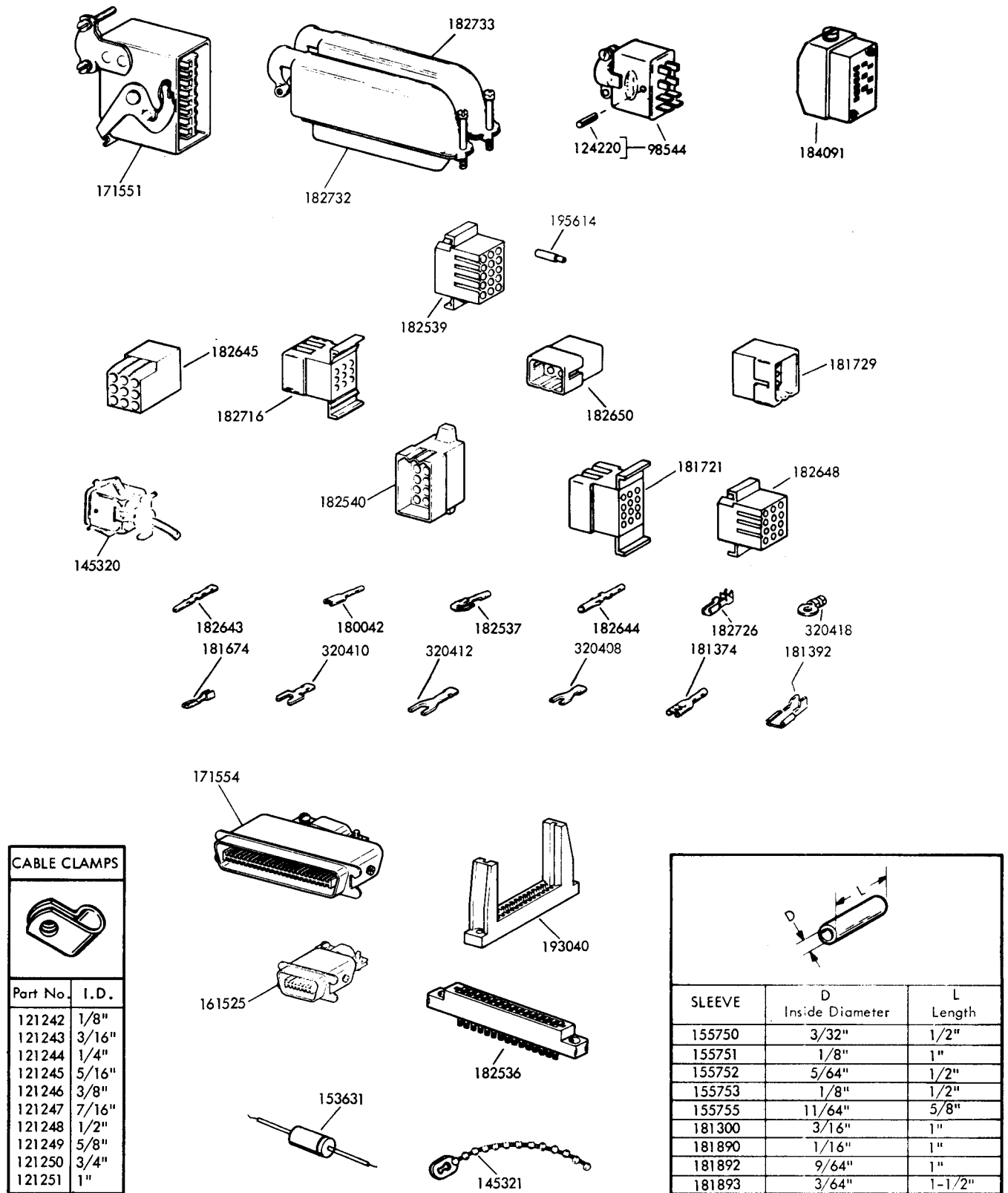
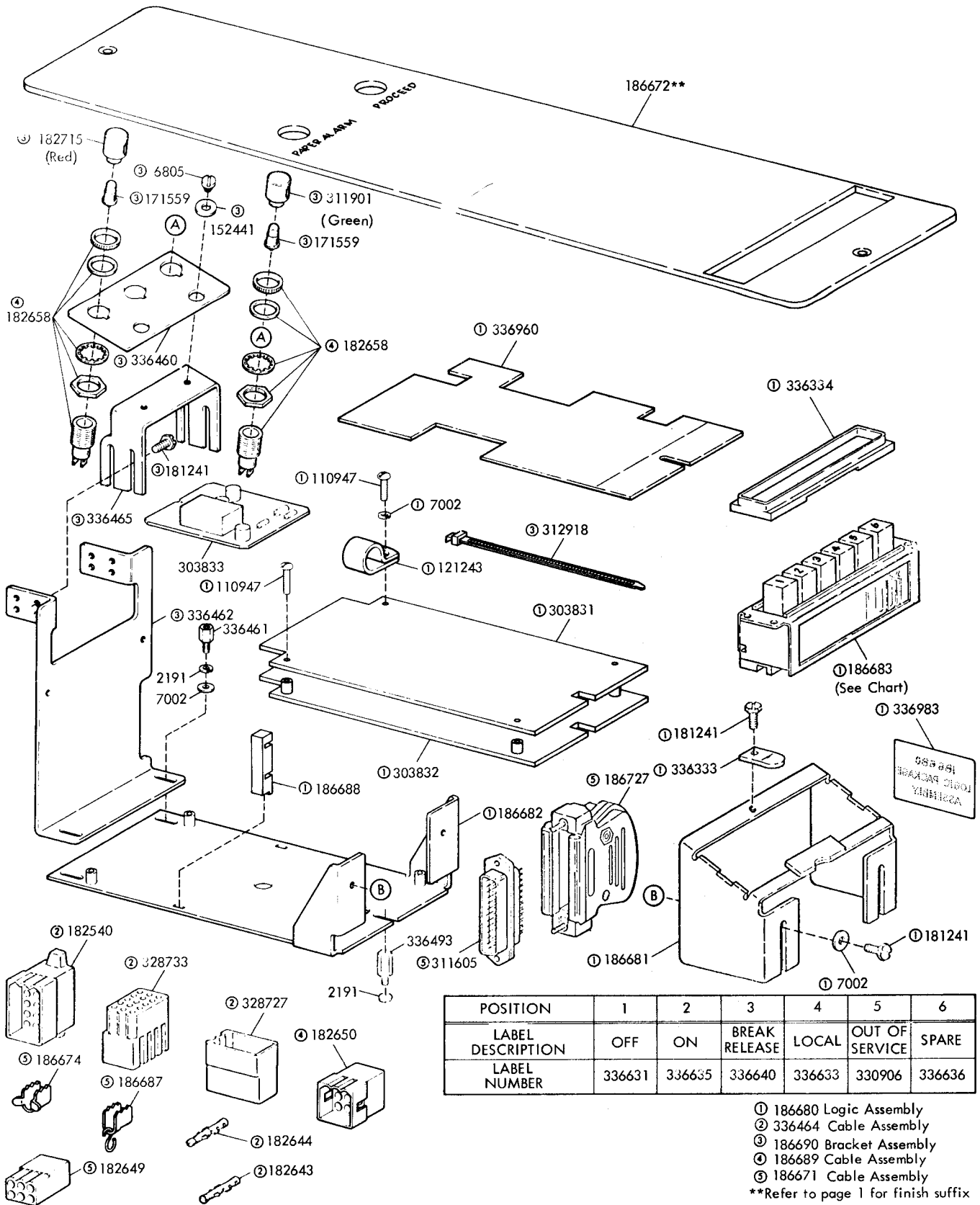

FIGURE 22. CABLE COMPONENTS



POSITION	1	2	3	4	5	6
LABEL DESCRIPTION	OFF	ON	BREAK RELEASE	LOCAL	OUT OF SERVICE	SPARE
LABEL NUMBER	336631	336635	336640	336633	330906	336636

- ① 186680 Logic Assembly
 - ② 336464 Cable Assembly
 - ③ 186690 Bracket Assembly
 - ④ 186689 Cable Assembly
 - ⑤ 186671 Cable Assembly
- **Refer to page 1 for finish suffix

FIGURE 23. 186670 MODIFICATION KIT TO PROVIDE PRIVATE LINE

NUMERICAL INDEX

Part Number	Description and Page Number	Part Number	Description and Page Number	Part Number	Description and Page Number
1010	Screw, 6-40 Shoulder 15	113442	Jumper, 2-1/2" Brown 22	151415	Block, Terminal 3
1028	Screw, 4-40 x 1/4 Fil 3	115594	Nut, Speed 15	151416	Nut, 6-40 Hex 3,5,6,7,8,9,12
1064	Screw, 6-32 x 1/2 Rd 12	117176	Fuse, SL-BL 0.5 Amp 2,6,7,17	151442	Screw, 6-40 x 1/2 Hex 4,8,10,12,16
1207	Screw, 4-36 x 5/16 Flat 15	120167	Fuse, SL-BL 3.2 Amp 6,7	151618	Screw, 6-40 x 7/16 Fil 12
2191	Lockwasher 2,3,4,5,8,9,10,11,12,14,16,17,24	121242	Clamp, 1/8 ID Cable 23	151660	Screw, 6-40 x 7/8 Fil 6,11,16
3598	Nut, 6-40 Hex 4,5,6,8,9,12,16	121243	Clamp, 3/16 ID Cable 23,24	151685	Screw, 4-40 x 5/16 Fil 13
3606	Nut, 6-40 Hex 4,11	121244	Clamp, 1/4 ID Cable 23	151687	Screw, 4-40 x 7/16 Fil 10
3640	Lockwasher 10,15	121245	Clamp, 5/16 ID Cable 7,8,23	151692	Screw, 6-40 x 3/16 Fil 7,9
3646	Lockwasher 8	121246	Clamp, 3/8 ID Cable 23	151693	Screw, 6-40 x 9/16 Fil 4
3649	Washer, Flat 4,6	121247	Clamp, 7/16 ID Cable 7,23	151731	Screw, 4-40 x 7/8 Fil 5,6,12
5599	Nut, 8-32 Hex 8	121248	Clamp, 1/2 ID Cable 23	151734	Screw, 4-40 x 3/8 Hex 15
6347	Screw, 6-32 x 3/8 Rd 13	121249	Clamp, 5/8 ID Cable 23	151738	Screw, Spl. 7
6805	Screw, 6-40 Shoulder 14,15,24	121250	Clamp, 3/4 ID Cable 23	151818	Jumper, 4-1/4" Black 22
7001	Washer, Flat 16	121251	Clamp, 1 ID Cable 23	151819	Jumper, 3" Black 22
7002	Washer, Flat 2 to 13,14,16,20,24	121551	Screw, 8-32 x 1/4 Hex 2,3,7,8,9	151827	Strap, Terminal 5,12
8330	Washer, Flat 8,9,12,16	124177	Lockwasher, 4,6,7,9,16,19,20	152441	Washer, Flat 14,15,24
42823	Washer, Flat 5,6,12	124220	Pin, Drive 23	152634	Washer, Flat 15
49054	Screw, 2-56 x 3/16 Flat 10	125011	Washer, Flat 2,3,15,16	152893	Screw, 4-40 x 1/4 Hex 2,3
70072	Lockwasher 4	125015	Washer, Flat 3,4,6,7,8,16	153484	Screw, 6-32 Spl 3
71073	Washer, Flat 16	125205	Screw, 6-40 x 7/16 Fil 16	153631	Network, Spark Suppression 5,12,22,23
75750	Washer, Insulating 3	125206	Screw, 6-32 x 5/8 Fil 22	153799	Screw, 4-40 x 21/64 Hex 3
77362	Resistor, 350 Ohm 3	138538	Fuse, SL-BL 2 Amp 7	154173	Plate 15
77902	Screw, 6-40 x 2-3/8 Rd 3	142269	Fuse, SL-BL 3 Amp 7,8,9	155750	Sleeve, 3/32 ID x 1/2" Lg Insulating 10,16,23
87993	Screw, 6-40 x 5/32 Fil 19	143613	Lamp, 14V Incandescent 2,15,17	155751	Sleeve, 1/8 ID x 1" Lg Insulating 23
90787	Screw, 4-40 x 3/8 Hex 2	144590	Screw, 6-40 x 1-3/8 Fil 4,16	155752	Sleeve, 5/64 ID x 1/2" Lg Insulating 16,23
91742	Locknut 22	145046	Connector, 3 Pt Plug 22	155753	Sleeve, 1/8 ID x 1/2" Lg Insulating 16,23
91943	Jumper, 2-1/4" Black 22	145047	Connector, 3 Pt Receptacle 22	155755	Sleeve, 11/64 ID x 5/8" Lg Insulating 10,16,23
92260	Lockwasher 12	145320	Connector, 4 Pt Receptacle 23	156450	Screw, 2-56 x 1/2 Fil 16
93117	Lockwasher 16	145321	Tie, Cable 23	156880	Jumper, 2-3/8" Black 13
96717	Screw, 4-40 Shoulder 2	150710	Screw, 6-40 x 1-1/4 Fil 8,16	159404	Post 10
98544	Connector, 8Pt Plug 23	150966	Insulator, Terminal 3	159931	Clamp 6,7
98726	Screw, 3-48 x 1/4 Fil 4	150978	Screw, 6-40 x 1-1/8 Fil 4	159932	Keeper 6,7
103092	Connector, Cord 22	150982	Screw, 4-40 x 7/16 Fil 3	160859	Terminal 16
103469	Screw, 4-40 Spl 10	151073	Screw, 4-40 x 5/32 Fil 20	161525	Connector, 14 Pt Plug 23
107116	Lockwasher 21	151152	Screw, 4-40 x 3/16 Hex 15	162360	Fuse, SL-BL .8 Amp 6,8
108463	Terminal 4,8	151335	Stud 3,5,6,7,8,9,12	165168	Key 10
110435	Nut, 4-40 Hex 16	151411	Block, Terminal 5,6,7,8,9,12	171441	Resistor, 560 Ohm 10
110743	Lockwasher 2,3,5,6,7,12,15,16,20	151412	Insulator, Terminal 5,6,7,8,9,12	171536	Resistor, 2,250 Ohm 5
110947	Screw, 6-32 x 13/16 Rd 24			171551	Connector, 16 Pt Plug 23
111017	Screw, 6-40 x 5/16 Fil 3,5,6,7,8,9,12				
111647	Resistor, 1,000 Ohm 3				
112485	Screw, 6-32 x 1/4 Fil 2,17				

NUMERICAL INDEX (Continued)

Part Number	Description and Page Number	Part Number	Description and Page Number	Part Number	Description and Page Number
171554	Connector, 50 Pt Plug 23	180904	Tab, Terminal 5,6,7,8,11	181809	Bracket, Switch 9
171559	Lamp, 28V Incandescent 10,14,24	181106	Plate, Baffle 15	181810	Relay 7
171593	Fuse, .5 Amp 7	181107	Bracket 15	181814	Capacitor, 250 MFD 7
177113	Insulator 4,8,12,16	181196	Ring, Retaining 7	181815	Driver Assembly, Selector Magnet 1,16
178306	Relay, Power 12	181204	Washer, Flat 10	181816	Resistor, 4,200 Ohm 7
178535	Suppressor, Spark 3,12	181240	Screw w/Lockwasher, 6-40 x 3/16 Hex 2,6,7,8,9,11, 12,14,17,20	181817	Bracket 7
178831	Connector, 2 Pt Receptacle 2,6,7,8,9,17	181241	Screw w/Lockwasher, 6-40 x 1/4 Hex 2 to 13,15,16, 17,18,19,20,24	181818	Cable Assembly 16
178832	Plate, Adapter 2,6,7,8,9, 17	181242	Screw w/Lockwasher, 6-40 x 5/16 Hex 7,8,9,10,16	181819	Connector, 15 Pt Circuit Card 11,12,14,16
178883	Resistor, 1,500 Ohm 5	181243	Screw w/Lockwasher, 6-40 x 3/8 Hex 6	181821	Card, Circuit 16
180042	Terminal, Tab Type 23	181245	Screw w/Lockwasher, 6-40 x 3/8 Hex 8	181822	Bracket 16
180586	Sleeve, 5/32 ID x 21/32" Lg Insulating 16	181246	Screw w/Lockwasher, 6-40 x 5/8 Hex 7,16	181824	Knob, Gray Pointer 7,8,9, 15
180877	Jumper, 2-3/4" White-Red 22	181263	Timer, Hour 6,12	181825	Cover, Relay 7
180878	Jumper, 2-3/4" White- Orange 22	181264	Bracket 6,12	181826	Jumper, 2" Black 22
180879	Jumper, 2-3/4" White- Yellow 22	181265	Timer w/Terminals 6	181827	Jumper, 2-3/4" White- Black 22
180880	Jumper, 2-3/4" White- Green 22	181266	Bushing, Insulating 16	181828	Jumper, 2-3/4" White- Orange 22
180881	Jumper, 2-3/4" White- Blue 22	181276	Plate, Name 6,12	181829	Jumper, 2-3/4" White- Blue 22
180882	Jumper, 2-3/4" White- Black 22	181281	Bracket, Right 20	181830	Jumper, 2-3/4" White- Yellow 22
180884	Jumper, 2-3/4 White- Slate 22	181282	Bracket, Left 20	181831	Jumper, 2-3/4" White- Purple 22
180886	Jumper, 2-1/2" Green 22	181283	Spacer, .065" Thk 3,20	181832	Jumper, 2-3/4" White- Brown 22
180887	Jumper, 2-1/2" Red 22	181287	Holder, Card 19,20	181836	Jumper, 4-1/2" Blue 22
180888	Jumper, 2-1/2" Blue 22	181289	Window, Plastic 18,19,20	181837	Jumper, 4-1/2" Black 22
180889	Jumper, 2-1/2" Yellow 22	181292	Window, Plastic 18,19	181840	Plate, Name 7
180890	Jumper, 2-1/2" White 22	181297	Cover, Insulating 5,6,7,8 9	181842	Plate, Name 7
180893	Jumper, 2-1/2" Red- Orange 22	181300	Sleeve, 3/16 ID x 1" Lg Insulating 23	181844	Plate, Name 7,8
180894	Jumper, 2-1/2" White- Blue 22	181374	Terminal, Tab Type 23	181845	Plate, Name 6,7
180895	Jumper, 2-1/2" White- Green 22	181392	Terminal, Tab Type 9,23	181857	Plate 8
180896	Jumper, 2-1/2" White- Yellow 22	181424	Nut, 6-40 Sq 7,8,16	181879	Transformer, Power 7
180897	Jumper, 2-1/2" White- Orange 22	181631	Strip Assembly, Lamp 2	181882	Bracket, Switch 8
180898	Jumper, 2-1/2" White-Red 22	181632	Button Assembly 2	181890	Sleeve, 1/16 ID x 1" Lg Insulating 22,23
180899	Jumper, 2-1/2" White- Purple 22	181637	Bracket 21	181892	Sleeve, 9/64 ID x 1" Lg Insulating 23
180900	Jumper, 2-1/2" Orange 22	181638	Contact Assembly 21	181893	Sleeve, 3/64 ID x 1-1/2" Lg Insulating 5,23
180902	Jumper, 3-1/2" Braided 22	181645	Dial, Rotary 2	181901**	Faceplate 19
		181661	Buzzer, 115V ac 2	181902**	Faceplate 20
		181672	Relay, Power 4	181903**	Faceplate 18
		181674	Terminal, Tab Type 23	181904**	Faceplate 20
		181675	Transistor, Power 4,8,12, 16	181906**	Faceplate 18
		181721	Connector, 12 Pt Plug Type 23	181994	Bracket, Guide 7
		181729	Connector Assembly 23	181999	Insulator 7,16

**Refer to page 1 for finish suffix

NUMERICAL INDEX (Continued)

Part Number	Description and Page Number	Part Number	Description and Page Number	Part Number	Description and Page Number
182044	Modification Kit 6	182565	Bracket 2	182695	Driver Assembly, Selector Magnet 1,16
182065	Plate, Identification 7,8	182566	Bracket, Left 2	182696	Cable Assembly 16
182066	Plate, Identification 8	182569	Clamp 5	182700	Plate, Base 3,6,7,15,16
182162	Post 4	182571	Screw, 6-40 Shoulder 2	182703	Bracket 16
182173	Spacer 8	182576	Bracket, Right 2	182704	Bracket 6,7,9
182182	Holder, Fuse 2,6,7,8,9, 12,17	182577	Bracket 2	182706	Plate, Pilot 15
182184	Fuse, 2.8 Amp 7,8	182581	Key Assembly 21	182707	Bracket, Pilot 15
182193	Insulator 3	182582	Key Assembly 21	182708	Bracket, Left 3
182251	Plate, Identification 4,7,16	182589	Key Assembly 21	182709	Bracket, Right 3,20
182284	Insulator, .015" Thk 7,16	182611	Fuse, SL-BL 3/8 Amp 5,6, 7,9	182710	Bracket, Upper 6,7,9
182287	Jumper, 6" Purple 6,22	182615	Pad 5	182711	Bracket, Lower 6,7
182489	Modification Kit 1,18	182619	Screw, 6-40 Shoulder 15	182713	Cap, Amber Lens 15
182494	Card Set, Index 19,20	182620	Dial, Touch Tone 18	182714	Cap, White Lens 2,10,14, 15,17
182495	Card Set, Dialing 19,20	182621	Dial, Touch Tone Card 19	182715	Cap, Red Lens 10,24
182500	Dial, Rotary 20	182622	Dial, DC Card 20	182716	Connector, 9 Pt Plug Type 16,23
182501	Capacitor, 1,500 MFD 4,8, 16	182623	Card, Circuit 11,16	182717	Board, Terminal 3
182502	Nut, No. 14 Speed 2,3,7, 8,9	182643	Terminal, Plug Type 5,9, 13,16,22,23,24	182718	Buzzer, 10V ac 3
182503	Ringer w/Terminals 15	182644	Terminal, Receptacle Type 5,9,13,22,23,24	182719	Bracket, Guide 6
182510	Cord, Power 22	182645	Connector, 9 Pt Receptacle Type 23	182720	Bracket, Dial 18
182520	Rectifier 6,7	182648	Connector, 12 Pt Receptacle Type 23	182721	Bracket 15
182523	Clamp, 1-3/8" ID Mounting 7,8,16	182649	Connector, 6 Pt Receptacle Type 24	182722	Transformer w/Terminals 16
182524	Button Assembly 3	182650	Connector, 6 Pt Plug Type 23,24	182723	Bracket 3,20
182527	Screw, 4-40 Shoulder 2	182653	Knob 15	182724	Plate, Dial 20
182529	Lamp, 10V 2,3	182655	Transformer, Power 6	182625	Plate, Tone Dialer 19
182532	Filter 20	182657	Socket, Lamp 2,10,15,17, 24	182726	Terminal, Receptacle Type 16,23
182533	Screw, 6-32 x 5/16 Rd 21	182658	Switch, Pushbutton 14,15	182727	Bracket, Left 20
182534	Screw, 4-40 Spl 21	182660	Holder, Fuse 5	182728	Bracket, Right 20
182535	Spring 21	182661	Bar, Latch 21	182729	Link, Ringer 15
182536	Connector, 15 Pt Circuit Card 4,6,16,23	182666	Plunger 21	182730	Bracket, Support 3
182537	Terminal, Tab Type 23	182667	Relay, Power 3	182731	Post 6,11,16
182539	Connector, 15 Pt Receptacle Type 5,6,7,9,12,23	182669	Jumper w/Spark Suppression 22	182732	Connector, 50 Pt Plug 23
182540	Connector, 15 Pt Plug Type 13,23,24	182679	Speaker, 2" 15	182733	Connector, 50 Pt Receptacle 23
182553	Plate, Base 21	182682	Resistor, 50 Ohm 15	182750	Card, Amplifier Circuit 6
182554	Spring, Compression 21	182683	Strap 3	182761	Capacitor, 0.5 MFD 3
182556	Lockout 21	182684	Strap 3	182768	Bracket, Fuse 7
182557	Bracket 21	182685	Resistor Assembly 50,000 Ohm 18,19	182769	Block 10,15
182558	Frame 21	182686	Switch, Turn Button 2,15, 17	182780	Jumper, 2-1/4" White-Black 22
182559	Plunger 21	182688	Jumper, 2-1/4" Orange 22	182781	Jumper, 2-3/4" White-Red 22
182561	Contact Assembly 21	182692	Jumper, 2-1/4" Orange 22	182782	Jumper, 2-3/4" White-Green 22
182562	Contact Assembly 21	182693	Jumper, 2-1/4" Orange 22	182783	Jumper, 2-3/4" White-Slate 22
182563	Plate w/Bracket 2				

NUMERICAL INDEX (Continued)

Part Number	Description and Page Number	Part Number	Description and Page Number	Part Number	Description and Page Number
182784	Jumper, 2-1/4" White-Orange 22	185677	Terminal, Receptacle Type 4,9,22	186681	Bracket 13,24
182785	Jumper, 2-1/4" White-Blue 22	185678	Plate, Identification 5,6,7	186682	Bracket 13,14,24
182786	Jumper, 2-1/4" White-Brown 22	185679	Plate, Identification 2,6,7,17	186683	Key Assembly 13,24
182787	Jumper, 2-1/4" White-Yellow 22	185680	Plate, Identification 12	186687	Band w/S Hook 24
182788	Jumper, 2-1/4" White-Purple 22	185682	Plate, Identification 7,9	186688	Block 24
182789	Resistor, 200 Ohm 18,19	185683	Plate, Identification 6,7	186689	Cable Assembly 24
182791	Bracket 2,17	185688	Plate, Identification 6,12	186690	Bracket Assembly, Lamp 24
182793	Plate, Heat Sink 16	186000	Driver Assembly, Selector Magnet 1,16	186727	Clamp 13,24
182794	Bracket 15	186059	Terminal 4,8,12,16	186739	Cover 16
182795	Switch, DP-DT 2,17	186164	Jumper, 6" Black 22	186741	Jumper, 9" Green 6,7,8
182796	Insulator, .032" Thk 6,7	186165	Jumper, 6" Red 22	186768	Bracket, Fuse 6
182799	Capacitor, 20-30 MFD 18,19	186166	Jumper, 6" Yellow 22	192007	Terminal, Tab Type 6,9,10
183111	Label 12,16	186224	Plate 2	193040	Connector w/Guide Slot 23
183141	Holder, Card 19,20	186318	Timer w/Terminals 6	193179	Lamp, 28V 10
183511	Plate, Pilot 15	186423	Insulator 11	193209	Connector, Receptacle Type 8
183512	Bracket, Switch 15	186424	Plate 12	193438	Strip, Lamp 3
183524	Button, Turn 2,15,17	186425	Plate, Base 11	193486	Modification Kit 1,20
183525	Washer, Flat 2,15,17	186426	Bracket 11,12	193487	Modification Kit 1,18
183526	Ring, Retaining 2,15,17	186427	Bracket 11	193488	Modification Kit 1,19
183985	Driver Assembly, Selector Magnet 1,16	186431	Cable Assembly 12	193489	Modification Kit 1,20
184011	Transformer w/Terminals 16	186434	Transformer 11	193706	Jumper, 3" White-Orange 22
184012	Driver Assembly, Selector Magnet 1,16	186438	Card, Circuit 11	193708	Jumper, 3" Black 22
184076	Cable Assembly 22	186439	Card, Circuit 11	195614	Pin, Key 5,6,7,9,23
184079	Jumper, White-Red 22	186448	Timer Assembly 5	195618	Jumper, 5-1/4" White-Purple 5
184080	Jumper, White-Orange 22	186463	Post 11	195924	Modification Kit 1,20
184081	Jumper, White-Yellow 22	186465	Timer Assembly 5	195926	Modification Kit 1,20
184082	Jumper, White-Green 22	186535	Bracket 12,14	195927	Modification Kit 1,19
184083	Jumper, White-Blue 22	186559	Dial, Touch-Tone 18	195940	Stud 10
184084	Jumper, White-Black 22	186595	Dial, Touch-Tone 19	197028	Terminal 9
184091	Connector, 12 Pt Plug 23	186596	Dial, Touch-Tone 19	197054	Jumper, 3" Black 9
184155	Cable Assembly 22	186597	Card Set, Dialing 19	197081	Switch, 3 Positions 7,8,15
184161	Bracket 8	186598**	Faceplate 18	197464	Diode 10
184162	Connector, 22 Pt Circuit Card 8	186599**	Faceplate 19	197939	Switch, Pushbutton 10
184166	Bracket 8	186600	Modification Kit 1,18	198515	Card, Circuit 4
184168	Card, Circuit 8	186601	Modification Kit 1,18	198517	Bracket 4
184169	Capacitor, 500-600 MFD 8	186602	Modification Kit 1,19	198518	Bushing, Insulating 4,8,12
184171	Strip, Terminal 8	186603	Modification Kit 1,19	198519	Insulator 4
184193	Transformer 8	186627	Logic Assembly 1,13	198520	Insulator, .062" Thk 4
184209	Insulator 8	186628	Bracket 6,7	198521	Bracket 4
185676	Terminal, Plug Type 9,16	186630	Modification Kit 1,14	198522	Clip, Spring 4,8
		186637	Card, Circuit 13	198528	Bracket 5
		186670	Modification Kit 1,24	198529	Strip, Terminal 5
		186671	Cable Assembly 24	198650	Key, Polarizing 8,16
		186672**	Faceplate 24	199311	Insulator 15
		186674	Stayband 24	199397	Bracket, Fuse 6,7,9
		186680	Logic Assembly 24	300340	Bushing 3,10,11

**Refer to page 1 for finish suffix

NUMERICAL INDEX (Continued)

Part Number	Description and Page Number	Part Number	Description and Page Number	Part Number	Description and Page Number
301713	Connector, 2 Pt Receptacle 2,6,7,12,17	327326	Jumper, 2-3/4" Green 12,22	330793	Transformer 16
302433	Button, Stud 11	327420	Modification Kit 1,20	330796	Transformer 4
303826	Card, Circuit 13	327806	Plug 13	330906	Label, Out of Service 13,24
303831	Card, Circuit 24	328362	Bar, Mounting 9	330923	Label, Alarm 13
303832	Card, Circuit 24	328363	Bracket, Guide 10	332709	Driver Assembly, Selector Magnet 1,16
303833	Card, Circuit 12,14,24	328382	Board, Terminal 10	333515	Shield, Transformer 16
304992	Bushing, Blocking 3	328383	Board, Cover 10	334652	Insulator, Switch 7,8
305453	Transformer w/Terminals 4	328389	Jumper, 8" Black 9	336333	Plate, Nut 13,24
305454	Transformer 4	328390	Jumper, 8" Black 9	336334	Collar 13,24
305688	Card, Circuit 5	328391	Jumper, 6" Orange 9	336460	Plate 14,24
305689	Card, Circuit 5	328392	Jumper, 6" Orange 9	336461	Post 14,24
311406	Terminal, Receptacle Type 12,16	328393	Jumper, 6" Black 9	336462	Bracket 14,24
311605	Connector, 25 Pt Plug 13,24	328394	Jumper, 8" Black 9	336464	Cable Assembly 13,24
311901	Cap, Green 24	328395	Jumper, 6" Black 9	336465	Bracket 14,24
312352	Card, Circuit 16	328396	Jumper, 8" White 9	336471	Cable Assembly 14
312918	Strap 24	328397	Jumper, 6" White 9	336493	Post 11,24
320408	Terminal, Spade Type 18, 19,23	328398	Jumper, 8" White 9	336601	Cable Assembly 13
320410	Terminal, Spade Type 6,9, 12,22,23	328399	Jumper, 8" White 9	336631	Label 13,24
320412	Terminal, Spade Type 4, 16,23	328400	Jumper, 8" Black 9	336632	Label 13
320418	Terminal, Ring Type 12, 14,22,23	328727	Connector, 15Pt Plug Type 13,24	336633	Label 13,24
320423	Plate 5	328733	Connector, 15Pt Receptacle Type 13,24	336635	Label 13,24
326635	Network, Spark Suppression 10	328739	Plate, Switch 10	336636	Label 24
327061	Lamp, 24V 13	328740	Bracket, Mounting 10	336640	Label 24
		328741	Post 10	336954	Screw, 4-40 x 13/64 Fil 13
		328742	Switch, Rotary 9	336956	Stayband 13
		328743	Switch, Lever 10	336957	Label 13
		328808	Plate, Base 9,10	336959	Cover 13
		330781	Shield, Transformer 4	336960	Cover 24
		330782	Shield, Transformer 4,16	336983	Label 24

33 TAPE READER (UX)
PARTS

FIGURE	CONTENTS	PAGE
1	Reader Mechanism	2
2	Tape Feed Magnet	3
3	Contact Block	3
4	Reed Switch and Magnet Core	4
5	Vibration Mounting	4
	Numerical Index	5

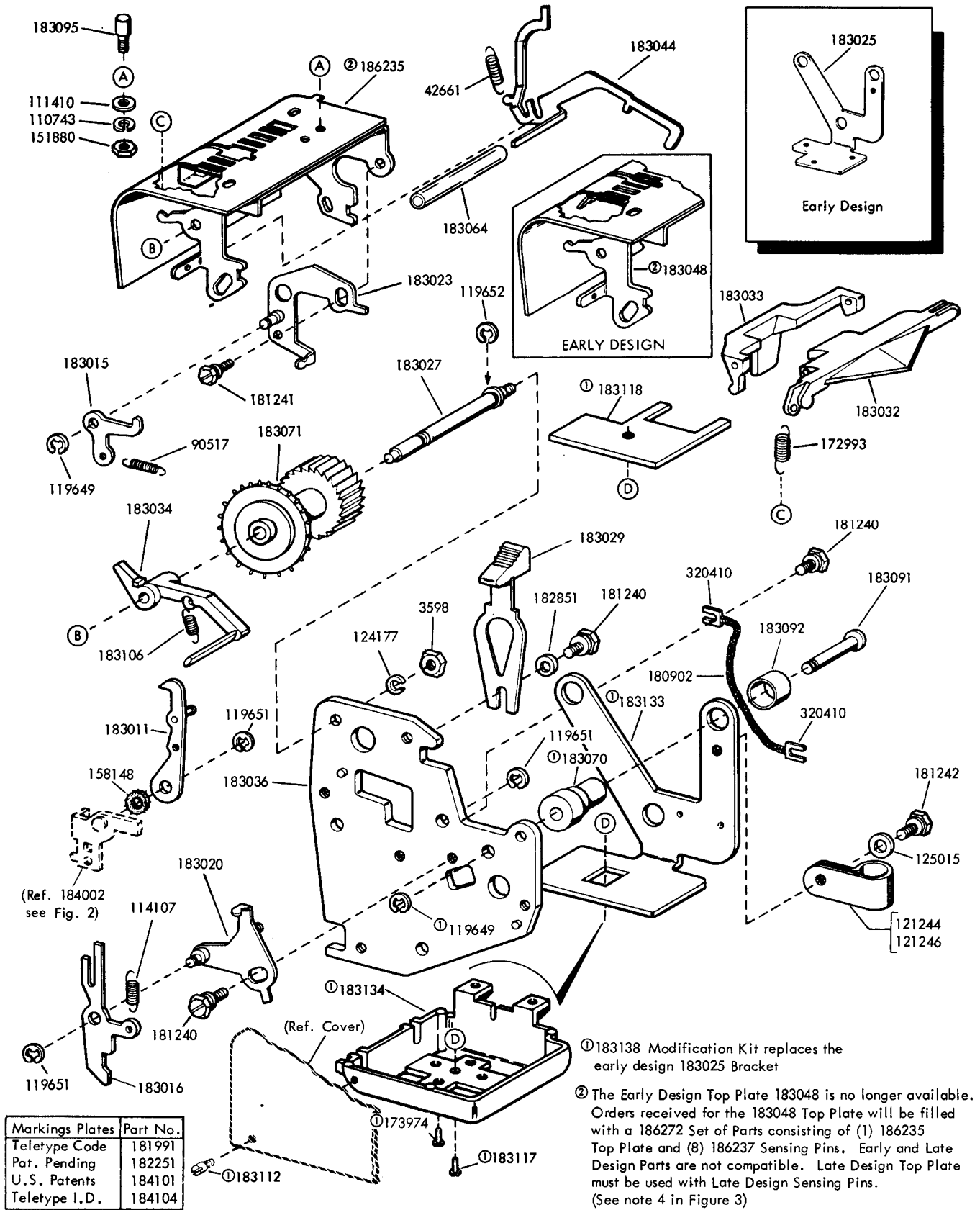

FIGURE 1. READER MECHANISM

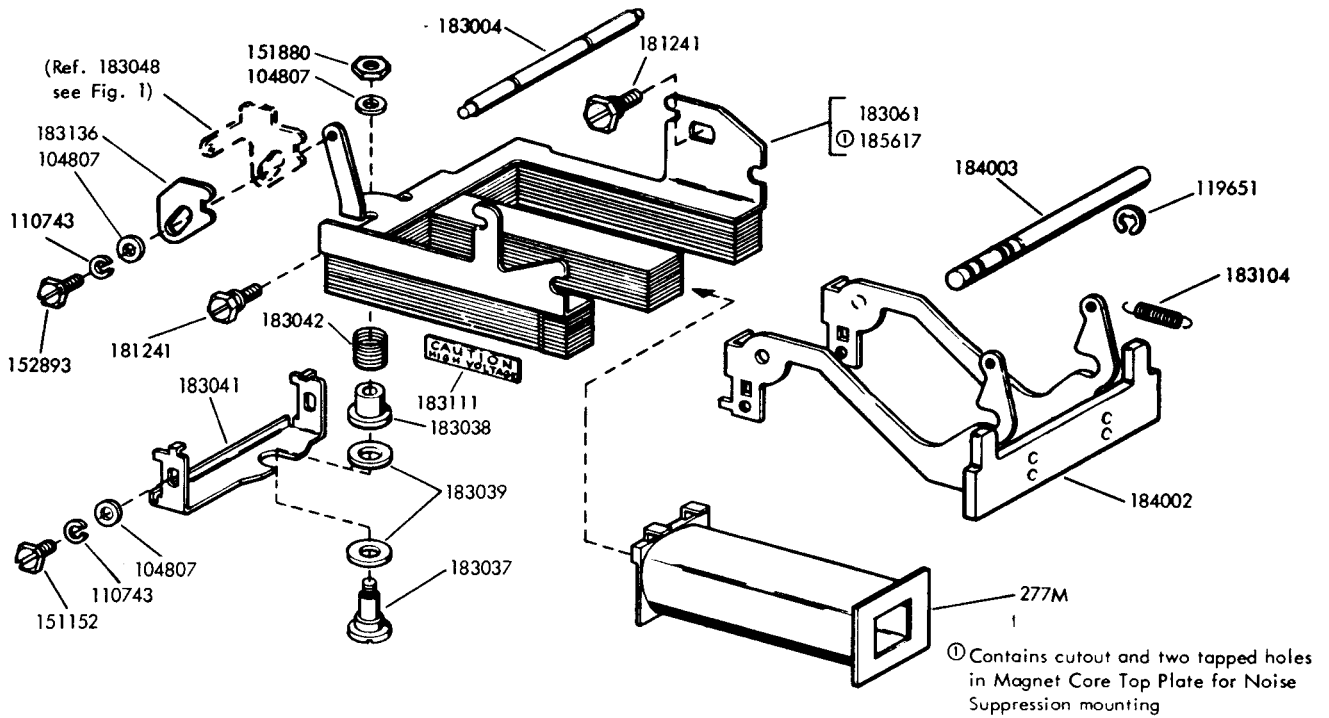

FIGURE 2. TAPE FEED MAGNET

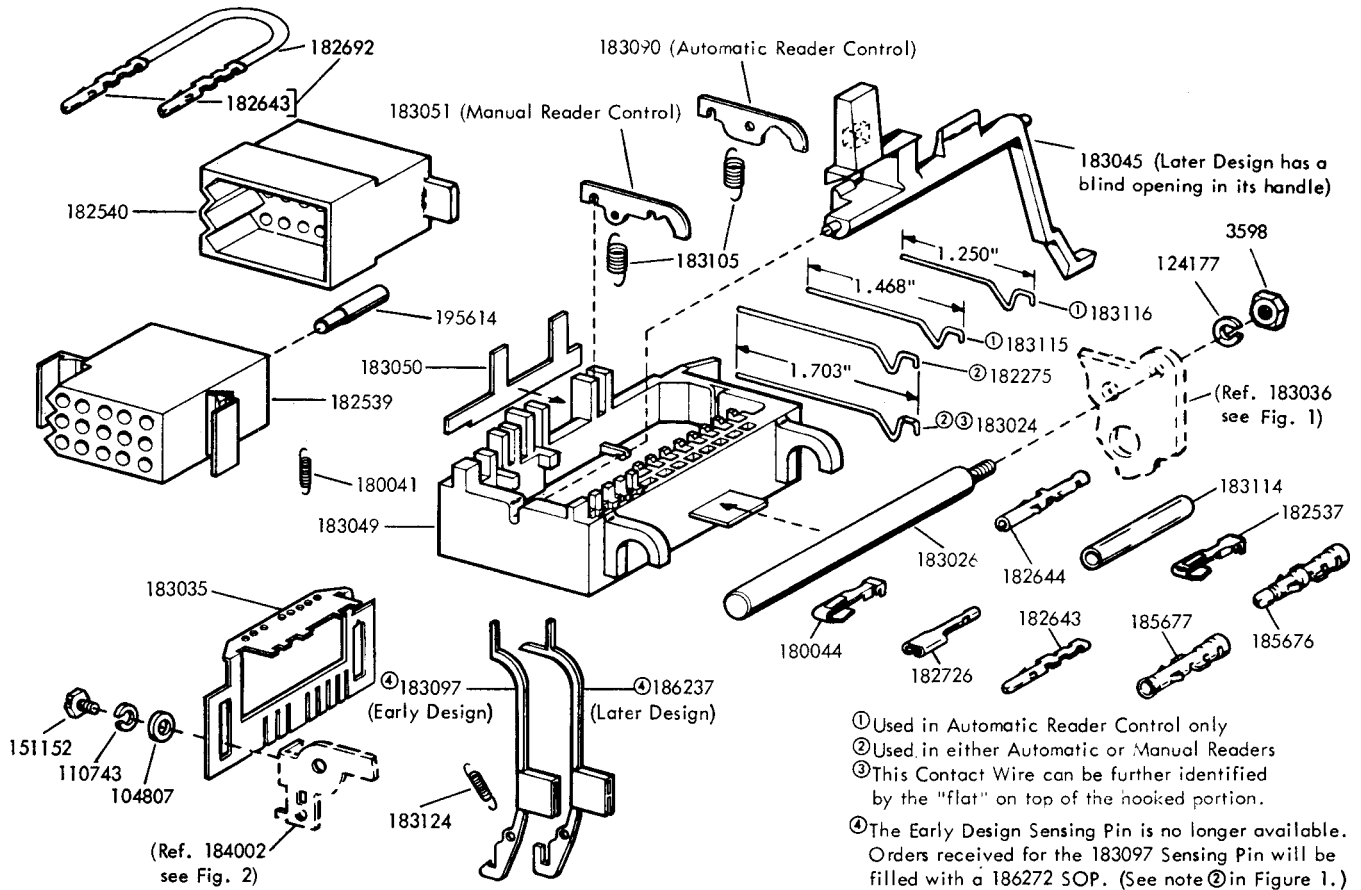

FIGURE 3. CONTACT BLOCK

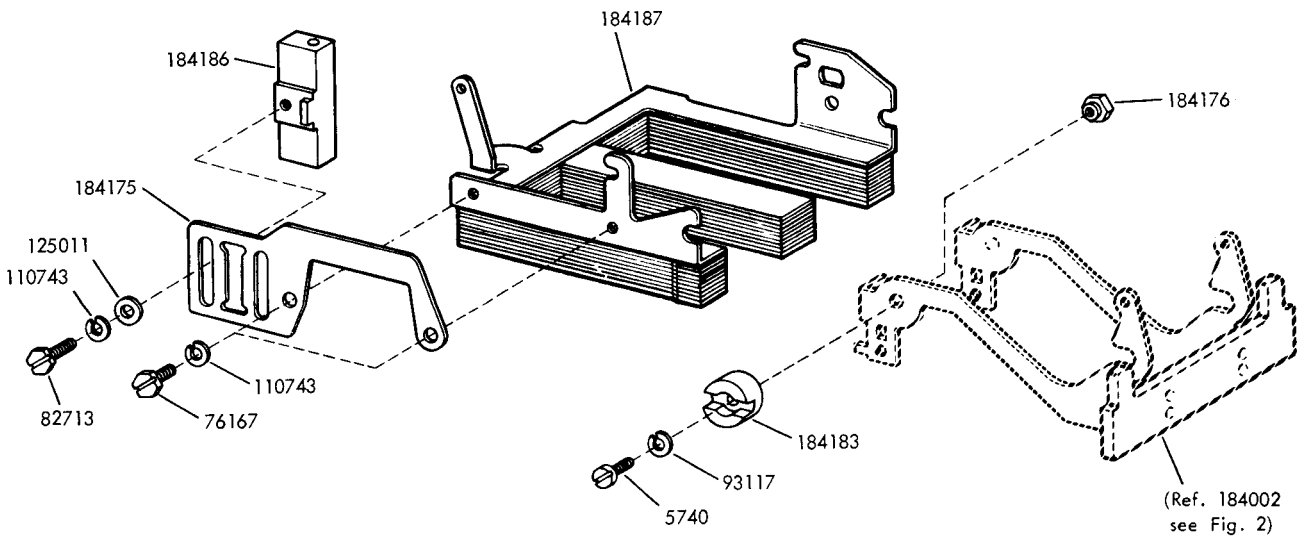

FIGURE 4. REED SWITCH AND MAGNET CORE

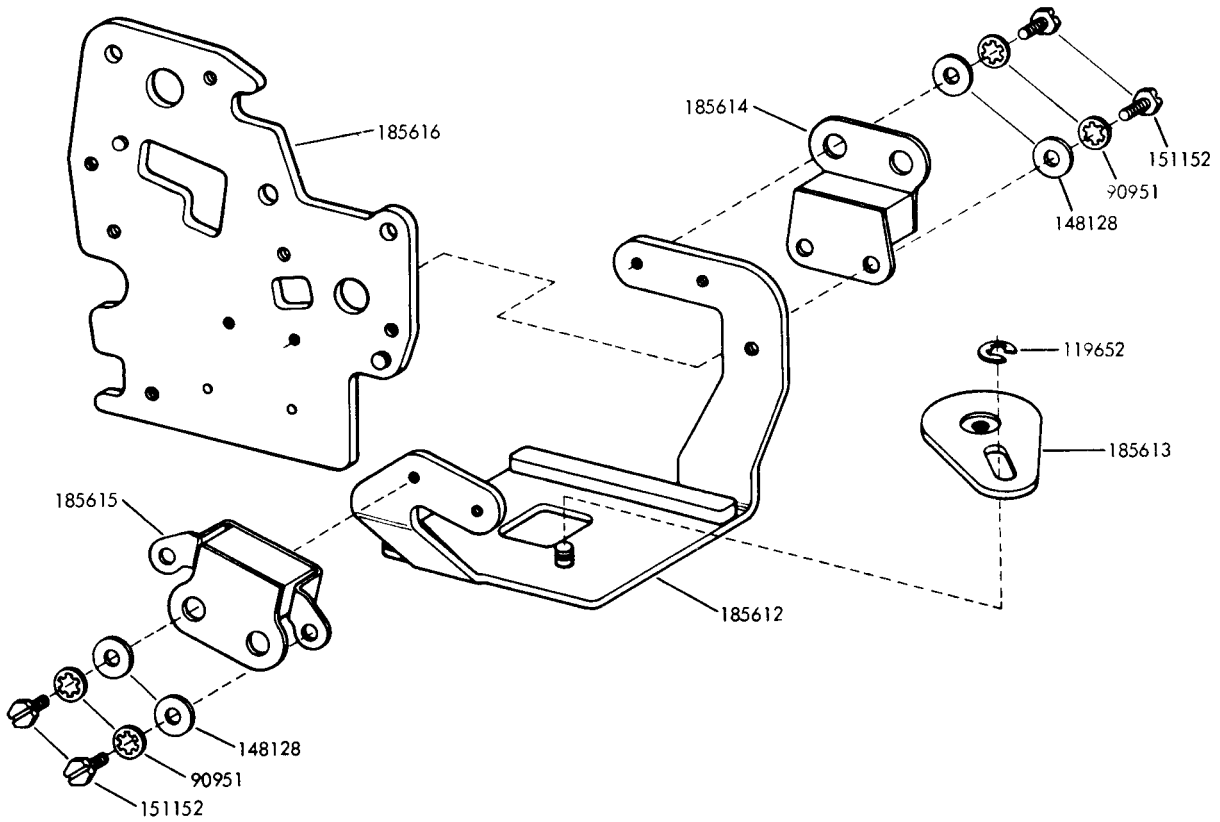

FIGURE 5. VIBRATION MOUNTING

NUMERICAL INDEX

Part Number	Description and Page Number	Part Number	Description and Page Number	Part Number	Description and Page Number
277M	Coil, Magnet 3	182540	Connector, 15 Pt Plug Type 3	183095	Stud, Tape Guide 2
3598	Nut, 6-40 Hex 2,3			183097	Pin, Sensing 3
5740	Screw, 2-56 x 1/4 Fil 4	182643	Terminal, Plug Type 3	183104	Spring 3
42661	Spring 2	182644	Terminal, Receptacle Type 3	183105	Spring 3
76167	Screw, 4-40 x 3/16 Hex 4			183106	Spring 2
82713	Screw, 4-40 x 9/32 Hex 4	182692	Jumper, 2-1/4" Orange 3	183111	Label 3
90517	Spring 2	182726	Terminal, Receptacle Type 3	183112	Screw, 4-40 x 9/16 Fil 2
90951	Lockwasher 4			183114	Sleeve, Insulating 3
93117	Lockwasher 4	182851	Spacer, .062" Thk 2	183115	Wire, Contact 3
104807	Washer, Flat 3	183004	Post, Spring 3	183116	Wire, Contact 3
110743	Lockwasher 2,3,4	183011	Pawl, Feed 2	183117	Screw, 10-32 x 5/8 Hex 2
111410	Washer, Flat 2	183015	Lever, Detent 2		
114107	Spring 2	183016	Pawl, Blocking 2	183118	Plate, Clamp 2
119649	Ring, Retaining 2	183020	Bracket, Blocking Pawl 2	183124	Spring 3
119651	Ring, Retaining 2,3	183023	Bracket, Detent 2	183133	Bracket 2
119652	Ring, Retaining 2,4	183024	Wire, Contact 3	183134	Base 2
121244	Clamp, 1/4 ID Cable 2	183025	Bracket 2	183136	Plate 3
121246	Clamp, 3/8 ID Cable 2	183026	Post, Contact Block 3	183138	Modification Kit 2
124177	Lockwasher 2,3	183027	Shaft, Feed Wheel 2	184002	Armature 2,3,4
125011	Washer, Flat 4	183029	Latch, Spring 2	184003	Shaft, Armature 3
125015	Washer, Flat 2	183032	Lid, Tape 2	184101	Plate, Identification 2
148128	Washer, Flat 4	183033	Bail, Tight Tape 2	184104	Plate, Identification 2
151152	Screw, 4-40 x 3/16 Hex 3,4	183034	Lever, Tight Tape 2	184175	Bracket 4
		183035	Guide, Sensing Pin 3	184176	Nut, 2-56 Shoulder Hex 4
151880	Nut, 4-40 Hex 2,3	183036	Backplate 2,3		
152893	Screw, 4-40 x 1/4 Hex 3	183037	Screw, 4-40 Shoulder 3	184183	Magnet 4
158148	Washer, Felt 2	183038	Bushing, Upstop 3	184186	Switch, Reed 4
172993	Spring 2	183039	Buffer, Upstop 3	184187	Core, Magnet 4
173974	Screw, 10-32 x 5/16 Hex 2	183041	Bracket, Upstop 3	185612	Bracket 4
180041	Spring 3	183042	Spring, Compression 3	185613	Plate, Nut 4
180044	Terminal, Tab Type 3	183044	Pin, Tape Out 2	185614	Mount, Left Vibration 4
180902	Jumper, 3-1/2" Braided 2	183045	Lever, Start-Stop 3	185615	Mount, Right Vibration 4
181240	Screw w/Lockwasher, 6-40 x 3/16 Hex 2	183048	Plate, Top 2,3	185616	Plate 4
181241	Screw w/Lockwasher, 6-40 x 1/4 Hex 2,3	183049	Block, Contact 3	185617	Core, Magnet 3
181242	Screw w/Lockwasher, 6-40 x 5/16 Hex 2	183050	Bar, Common 3	185676	Terminal, Plug Type 3
		183051	Lever, Detent 3	185677	Terminal, Receptacle Type 3
181991	Plate, Identification 2	183061	Core, Magnet 3		
182251	Plate, Identification 2	183064	Insulator, Tape Out Pin 2	186235	Plate, Top 2
182275	Wire, Contact 3	183070	Grommet, Rubber 2	186237	Pin, Sensing 2,3
182537	Terminal, Tab Type 3	183071	Wheel, Feed 2	186272	Set of Parts 2,3
182539	Connector, 15 Pt Receptacle Type 3	183090	Lever, Detent 3	195614	Pin, Key 3
		183091	Post 2	320410	Terminal, Spade Type 2
		183092	Cup 2		

33 TAPE PUNCH (UPE)
PARTS

FIGURE	CONTENTS	PAGE
1	Punch Mechanism	2
2	Punch Mechanism (Continued)	3
3	Power Bail Mechanisms	4
	Numerical Index	5

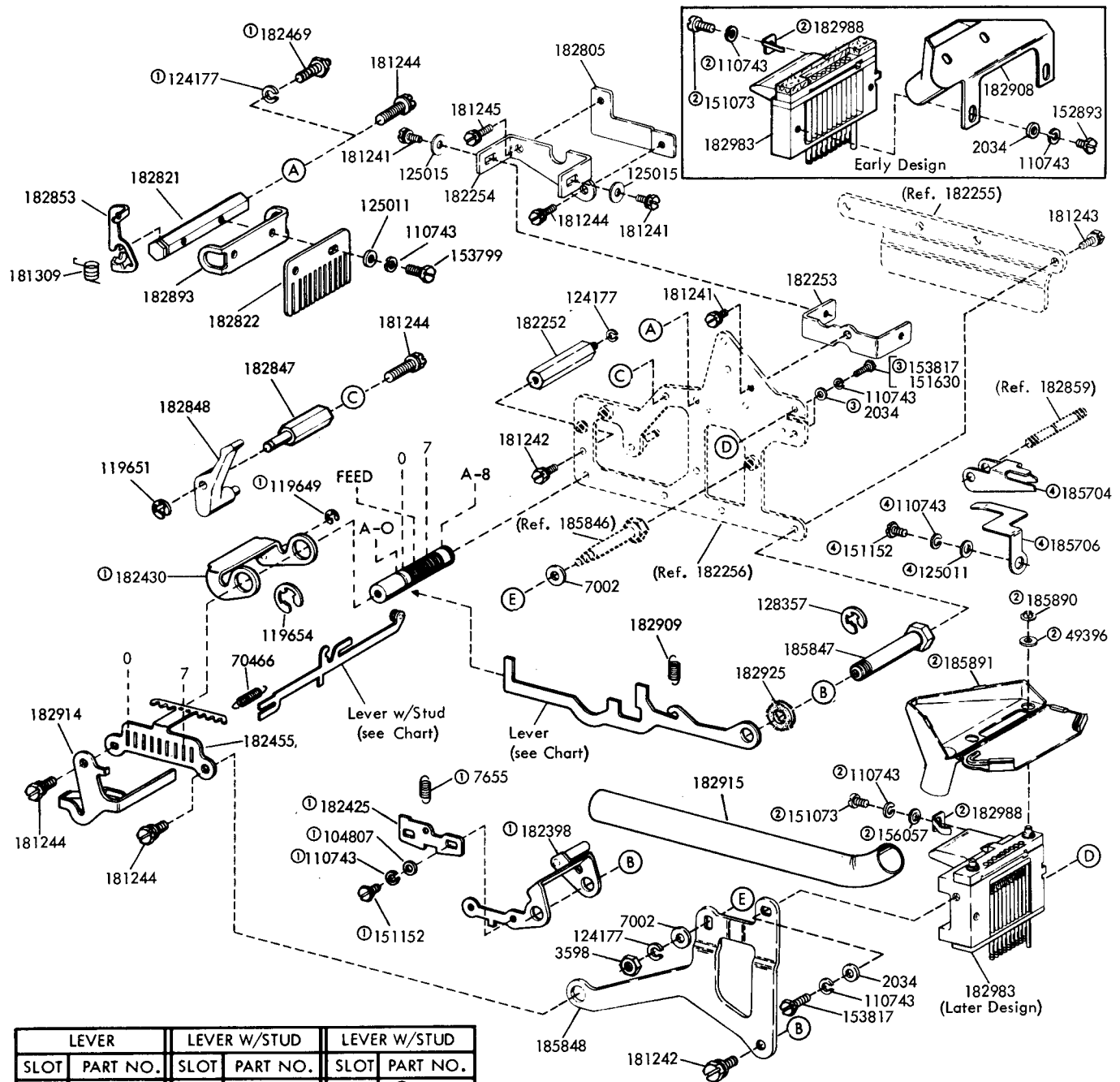

LEVER		LEVER W/STUD		LEVER W/STUD	
SLOT	PART NO.	SLOT	PART NO.	SLOT	PART NO.
A-O	①182457	0	182862	1	①182403
0	182431	1-8	182884	2	①182402
1	182432	2-8	182885	3	①182404
2	182433	3	182864	4	①182864
FEED	182872	4-8	182886	5	①182406
3	182434	6	182887	6	①182887
4	182435	5	182861	7	①182861
5	182437	7	182888	8	①182888
6	182438				
7	182439				
A-8	①182457				

NOTE: Early and Later Design Punch Block Assemblies are interchangeable; however, the 182908 Chad Chute can only be used on the Early Design and the 185891 can only be used on the Later Design.

- ① Peculiar to units with Automatic On-Off Controls
- ② Supplied with 182983
- ③ Peculiar to units with Manual On-Off Controls
- ④ 185705 Modification Kit to provide a guide for Fan Fold Tape

FIGURE 2. PUNCH MECHANISM (Continued)

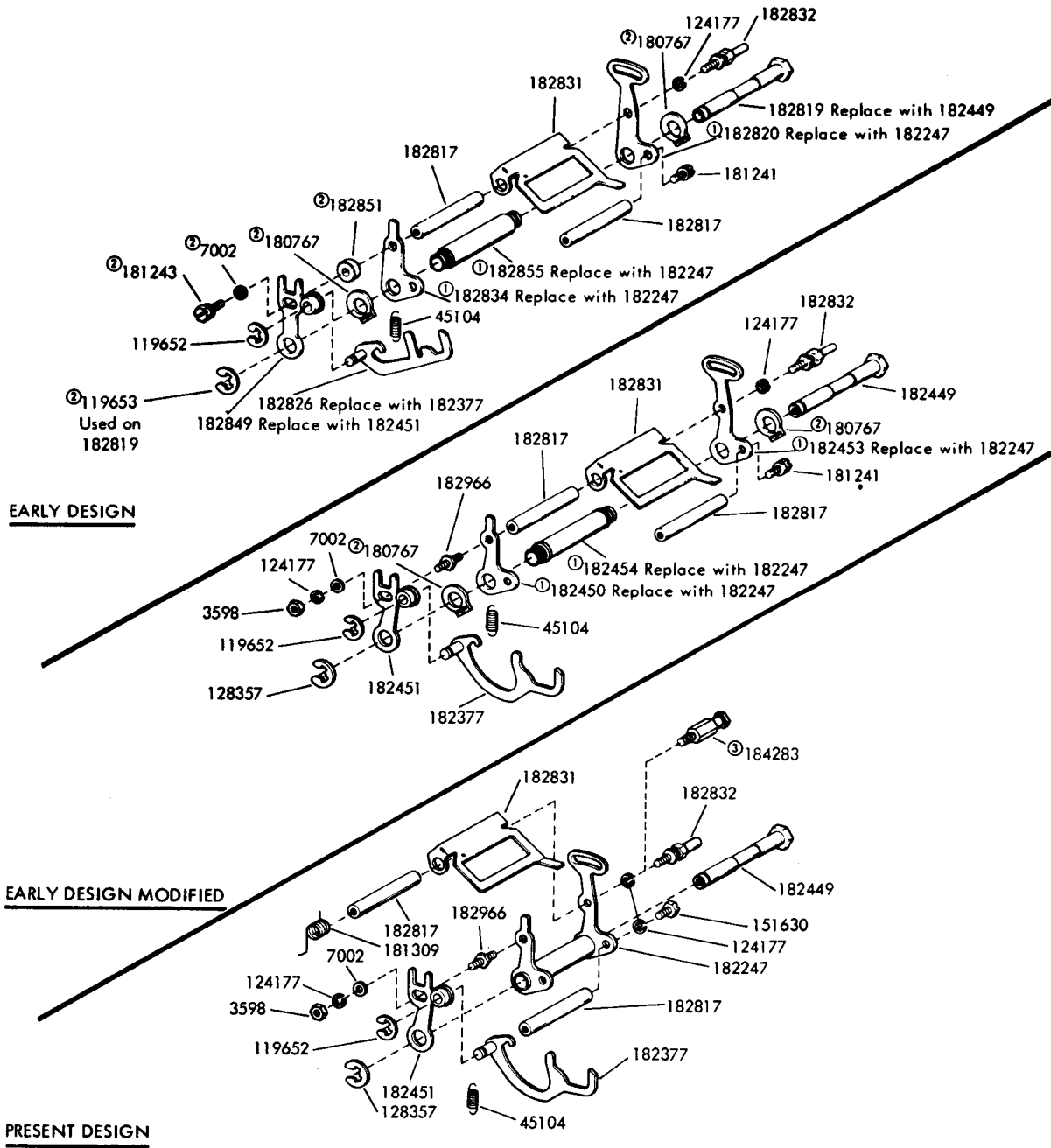

- ① Must be replaced with 182247 Sleeve w/Plates, 181309 Spring and 128357 Ring, Retaining (3598, 124177, 7002 and 182966 may also be ordered to update entire Power Bail Mechanism)
- ② Use only with Earlier Design Mechanisms
- ③ Peculiar to units with automatic ON-OFF controls

FIGURE 3. POWER BAIL MECHANISMS

NUMERICAL INDEX

Part Number	Description and Page Number	Part Number	Description and Page Number	Part Number	Description and Page Number
2034	Washer, Flat 2,3	181244	Screw w/Lockwasher, 6-40 x 7/16 Hex 2,3	182454	Sleeve 4
2415	Spring 2	181245	Screw w/Lockwasher, 6-40 x 1/2 Hex 3	182455	Bracket 3
3598	Nut, 6-40 Hex 2,4	181309	Spring, Torsion 3,4	182457	Lever 3
7002	Washer, Flat 2,3,4	182247	Sleeve w/Plates 4	182460	Link 2
7603	Spring 2	182252	Post 3	182465	Bracket 2
7655	Spring 3	182253	Bracket 3	182466	Lever w/Post 2
8449	Spacer, 0.094" Thk 2	182254	Bracket 3	182469	Post, Spring 3
45104	Spring 4	182255	Spacer 2,3	182802	Bracket 2
49396	Washer, Flat 3	182256	Plate 2,3	182803	Plate 2
70466	Spring 3	182377	Pawl w/Stud 4	182805	Plate 3
73035	Spring 2	182382	Lever 2	182807	Lever 2
82463	Spring 2	182384	Lever 2	182808	Lever 2
90054	Spring 2	182386	Lever 2	182810	Pawl 2
104807	Washer, Flat 3	182387	Lever 2	182811	Pawl 2
110743	Lockwasher 2,3	182388	Post 2	182812	Lever 2
119649	Ring, Retaining 2,3	182389	Lever 2	182813	Lever 2
119651	Ring, Retaining 2,3	182390	Link 2	182814	Lever 2
119652	Ring, Retaining 2,4	182392	Post 2	182815	Bracket 2
119653	Ring, Retaining 2,4	182393	Lever 2	182816	Shaft 2
119654	Ring, Retaining 3	182394	Lever 2	182817	Post 4
124177	Lockwasher 2,3,4	182395	Post 2	182819	Post 4
125011	Washer, Flat 2,3	182397	Lever 2	182820	Plate 4
125015	Washer, Flat 2,3	182398	Bail w/Post 3	182821	Post 3
128357	Ring, Retaining 2,3,4	182399	Post, Eccentric 2	182822	Plate 3
150436	Bushing 2	182400	Plate w/Stud 2	182823	Post 2
151073	Screw, 4-40 x 5/32 Fil 3	182402	Lever w/Stud 3	182826	Pawl w/Stud 4
151152	Screw, 4-40 x 3/16 Hex 2,3	182403	Lever w/Stud 3	182827	Plate 2
151442	Screw, 6-40 x 1/2 Hex 2	182404	Lever w/Stud 3	182828	Roller 2
151630	Screw, 6-40 x 1/4 Hex 3,4	182406	Lever w/Stud 3	182829	Sleeve 2
151737	Screw, 4-40 x 11/64 Hex 2	182409	Arm w/Hub 2	182831	Bail 4
152893	Screw, 4-40 x 1/4 Hex 3	182412	Lever w/Stud 2	182832	Post 4
153817	Screw, 4-40 x 3/8 Hex 3	182425	Arm 3	182834	Plate 4
153799	Screw, 4-40 x 21/64 Hex 3	182428	Link 2	182837	Lever w/Post 2
156057	Washer, Flat 3	182429	Plate 2	182839	Plate 2
162886	Screw, 4-40 x 7/32 Hex 2	182430	Bail w/Stud 3	182843	Lever 2
180767	Ring, Retaining 4	182431	Lever 3	182844	Roller 2
181240	Screw w/Lockwasher, 6-40 x 3/16 Hex 2	182432	Lever 3	182845	Post 2
181241	Screw w/Lockwasher, 6-40 x 1/4 Hex 3,4	182433	Lever 3	182846	Roller 2
181242	Screw w/Lockwasher, 6-40 x 5/16 Hex 3	182434	Lever 3	182847	Post 3
181243	Screw w/Lockwasher, 6-40 x 3/8 Hex 2,3,4	182435	Lever 3	182848	Arm 3
		182437	Lever 3	182849	Plate w/Bushing 4
		182438	Lever 3	182851	Spacer, 0.062" Thk 4
		182439	Lever 3	182853	Hook 3
		182449	Post 4	182854	Bracket 2
		182450	Plate 4	182855	Sleeve 4
		182451	Plate w/Bushing 4	182856	Wheel, 24T 2
		182452	Guideplate 2	182857	Roller 2
		182453	Plate 4	182858	Post 2
				182859	Post 2,3
				182861	Lever w/Stud 3

NUMERICAL INDEX (Continued)

Part Number	Description and Page Number	Part Number	Description and Page Number	Part Number	Description and Page Number
182862	Lever w/Stud 3	182890	Plate 2	184095	Spring 2
182864	Lever w/Stud 3	182893	Bracket 3	184200	Bail 2
182872	Lever 3	182904	Spring, Compression 2	184283	Guidepost 4
182878	Lever 2	182908	Chute, Chad 3	185704	Depressor, Tape 3
182879	Lever 2	182909	Spring 3	185705	Modification Kit 3
182882	Link 2	182914	Bracket 3	185706	Bracket 3
182884	Lever w/Stud 3	182915	Extension 3	185776	Spring 2
182885	Lever w/Stud 3	182925	Washer, Flat 2,3	185777	Spring 2
182886	Lever w/Stud 3	182936	Arm w/Bushing 2	185846	Post 2,3
182887	Lever w/Stud 3	182966	Stud 4	185847	Post 3
182888	Lever w/Stud 3	182983	Block Assembly, Punch 3	185848	Plate 3
182889	Lever 2	182988	Spring, Punch Block 3	185890	Pushnut 3
				185891	Chute, Chad 3

33 COVER AND TABLE
PARTS

FIGURE	CONTENTS	PAGE
1	Printer Covers	2
2	Punch Cover and Base	3
3	Reader Cover and Base	4
4	Faceplates	5
5	Cover and Tape Storage Bin	6
6	Cabinet	7
7	Lid and Copyholder	8
8	183976 Adjustable Copyholder Assembly	9
9	182134, 182149, 184194 and 186480 Power Pack Assemblies	10
10	181720 Power Pack Assembly	10
11	184074 Outlet Box Assembly	11
12	183859 Modification Kit to Provide Paper Supply and Accumulating Shelf	12
13	186031 Rectifier Assembly	13
14	186226 Modification Kit to Provide Mobility for Cabinet	14
	Numerical Index	15

**Denotes a painted part.
HF-Light Olive Gray Smooth Vinyl

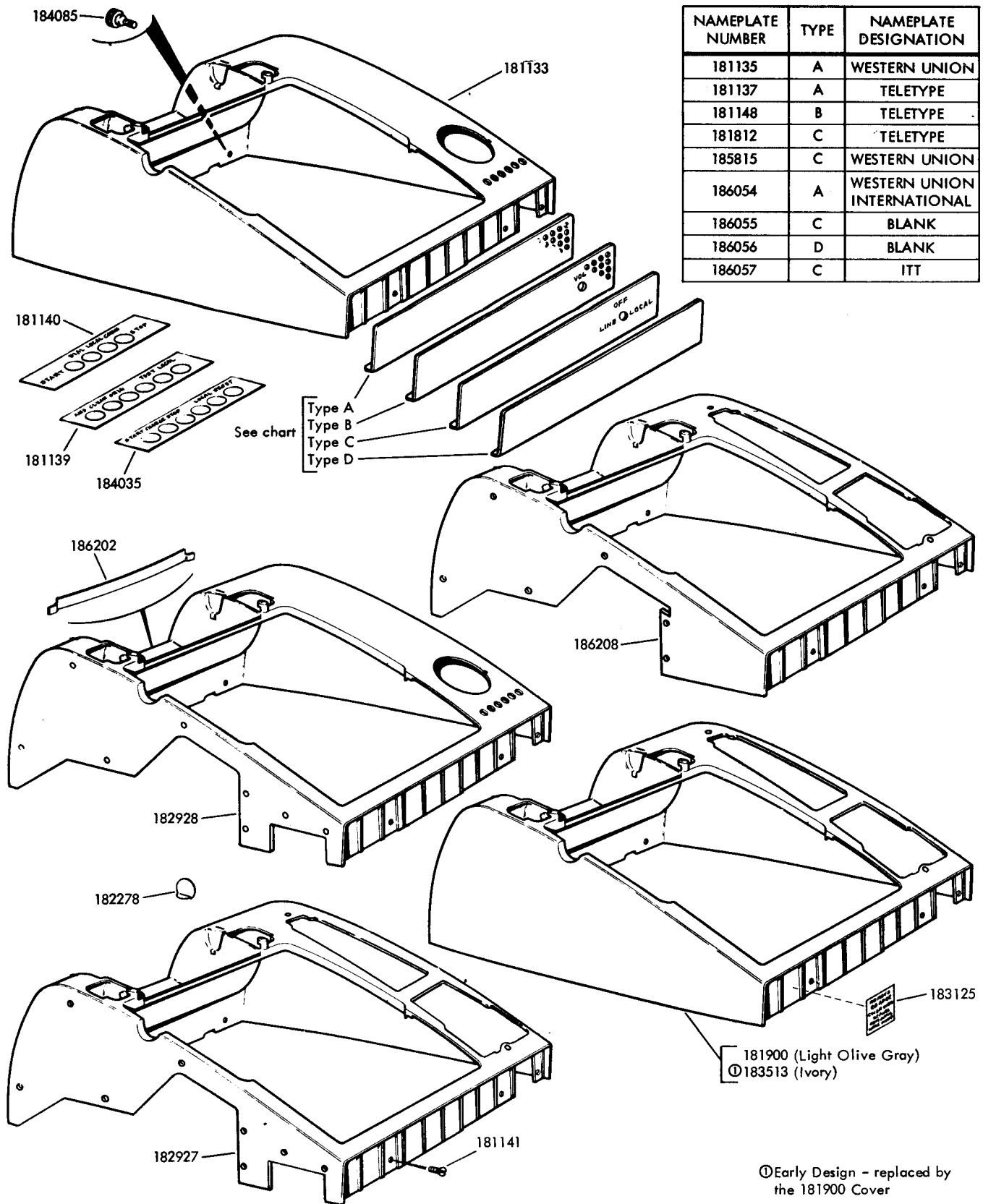
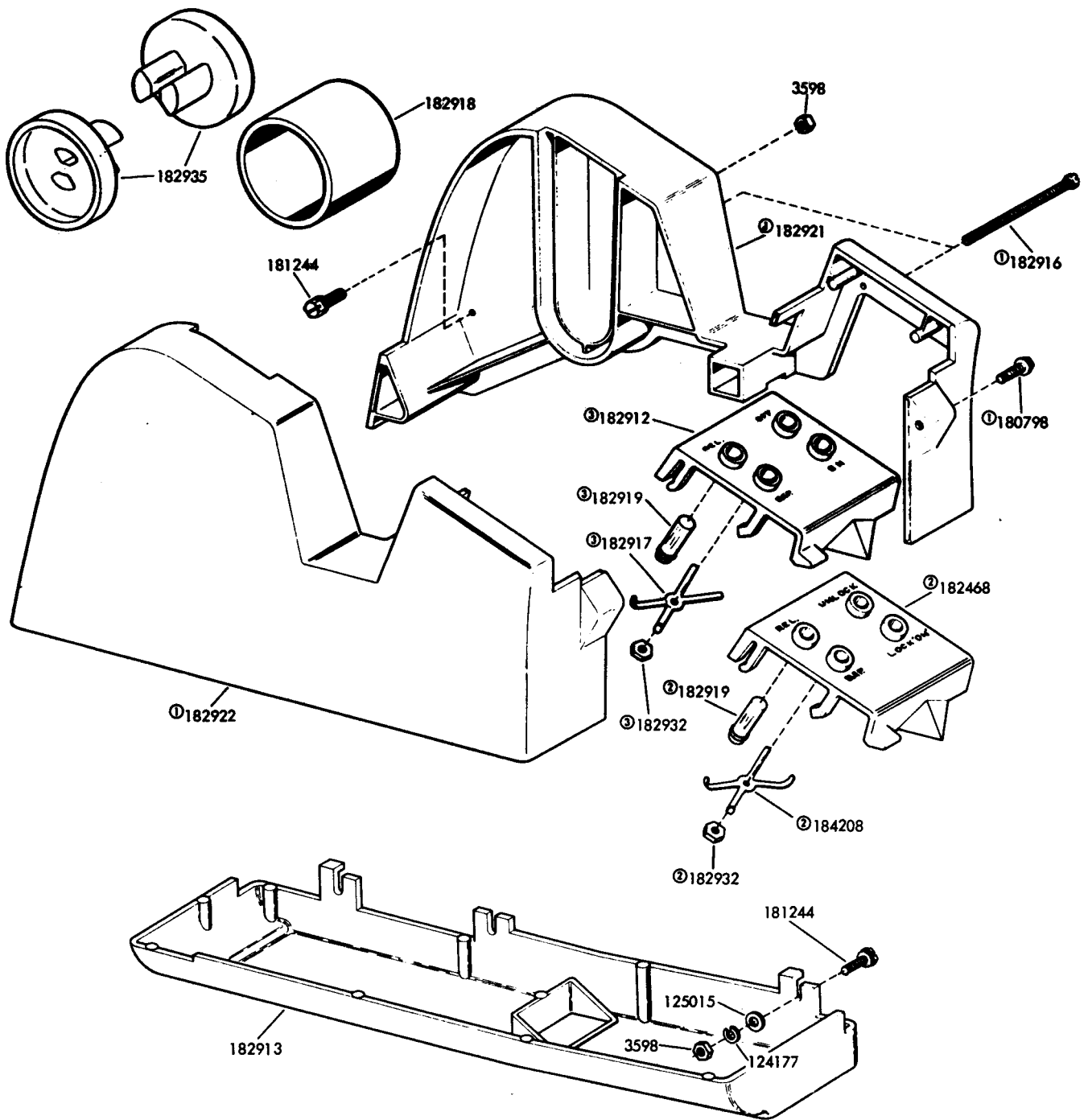
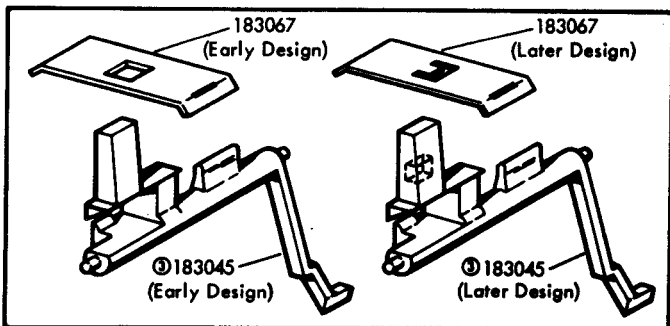
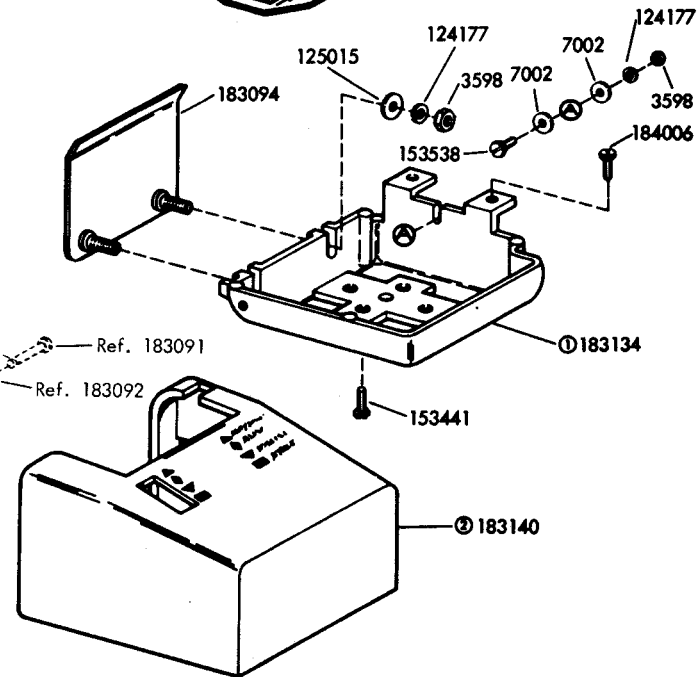
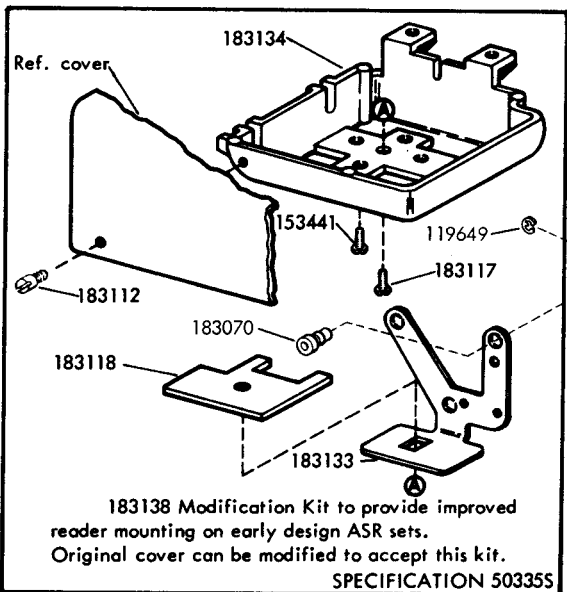
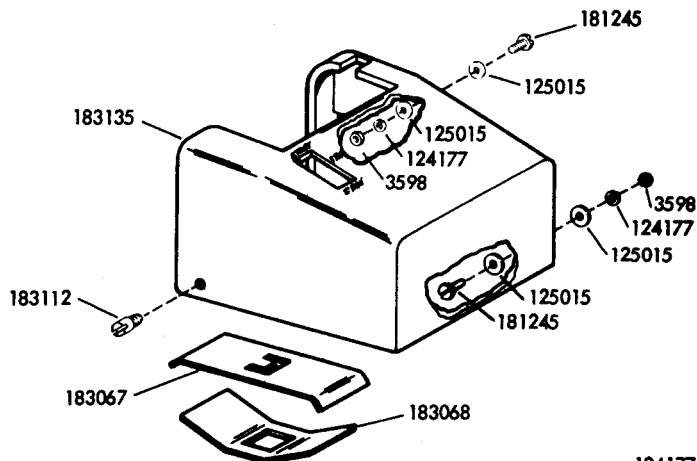
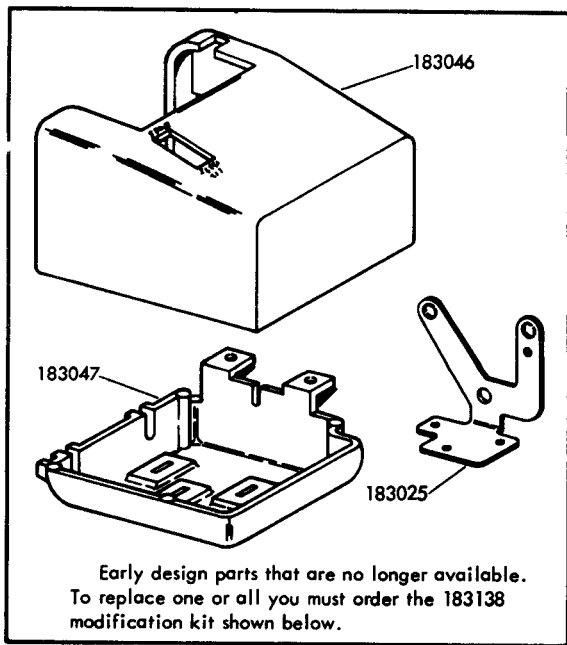

FIGURE 1. PRINTER COVERS



- ① 182926 Cover Assembly
- ② 184206 Lid Assembly (for automatic On-Off control)
- ③ 182109 Lid Assembly (for manual On-Off control)

FIGURE 2. PUNCH COVER AND BASE



① A new 185700 laminated sheet steel base has been designed to replace the three individual castings mounting the typing unit with motor, keyboard and associated call control unit, the perforator, and the reader. However, the 183134 base (shown on this figure) is still available for replacement purposes

② Automatic reader control cover.

③ The 183067 shield and the 183045 start & stop lever have been redesigned but retain their original numbers. The new style lever can be used with the old style shield but the new style shield must be used with the new style lever

FIGURE 3. READER COVER AND BASE

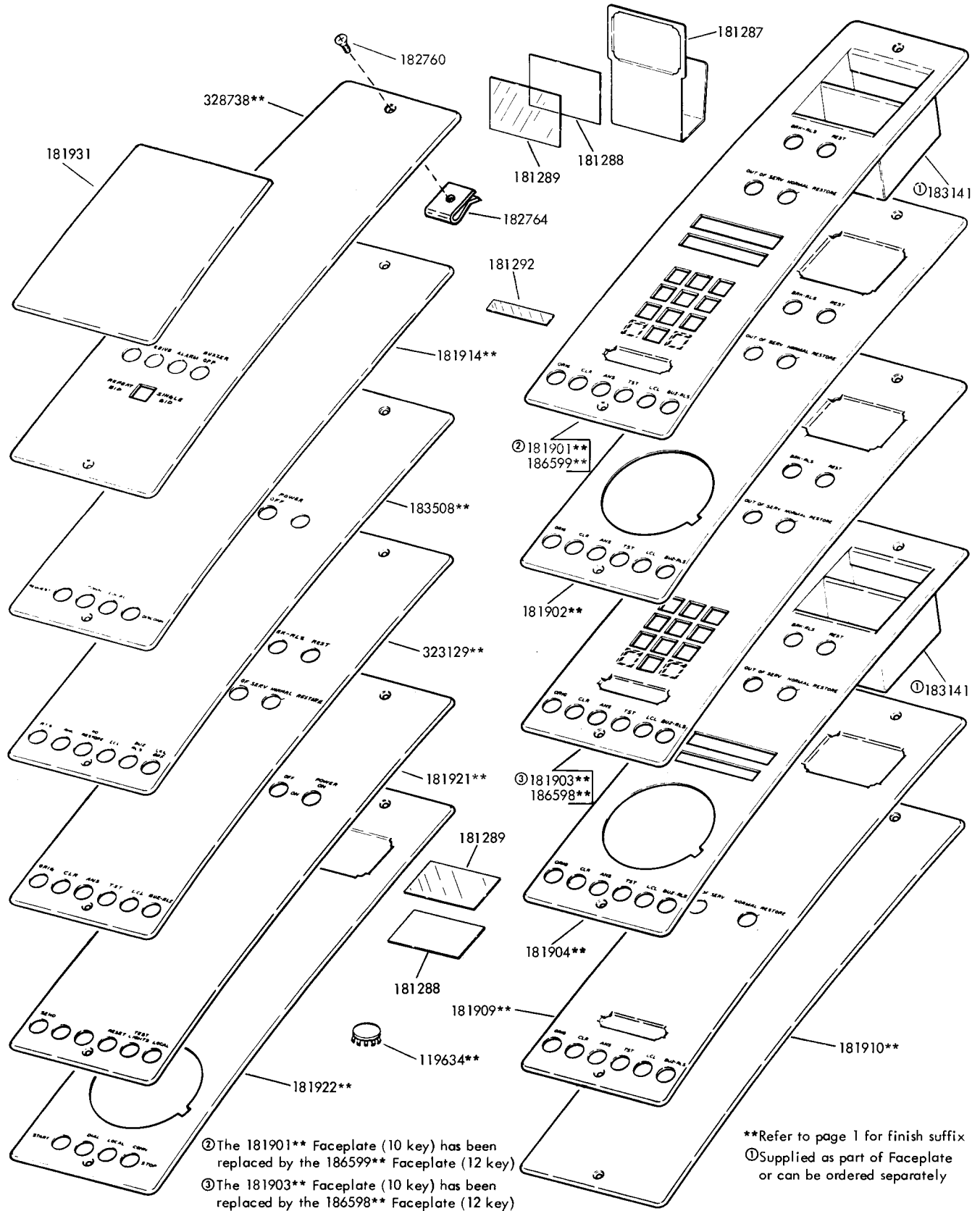

FIGURE 4. FACEPLATES

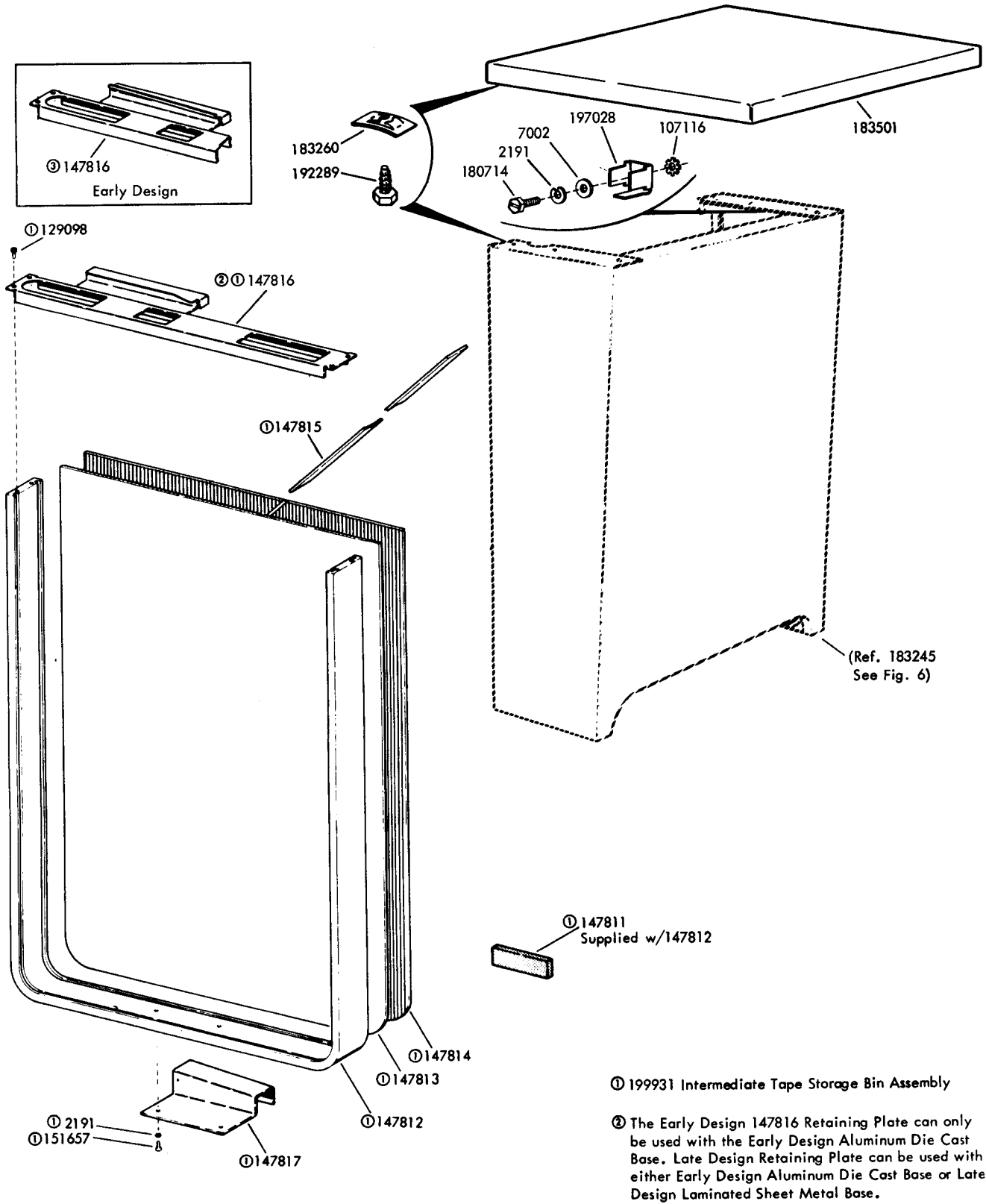
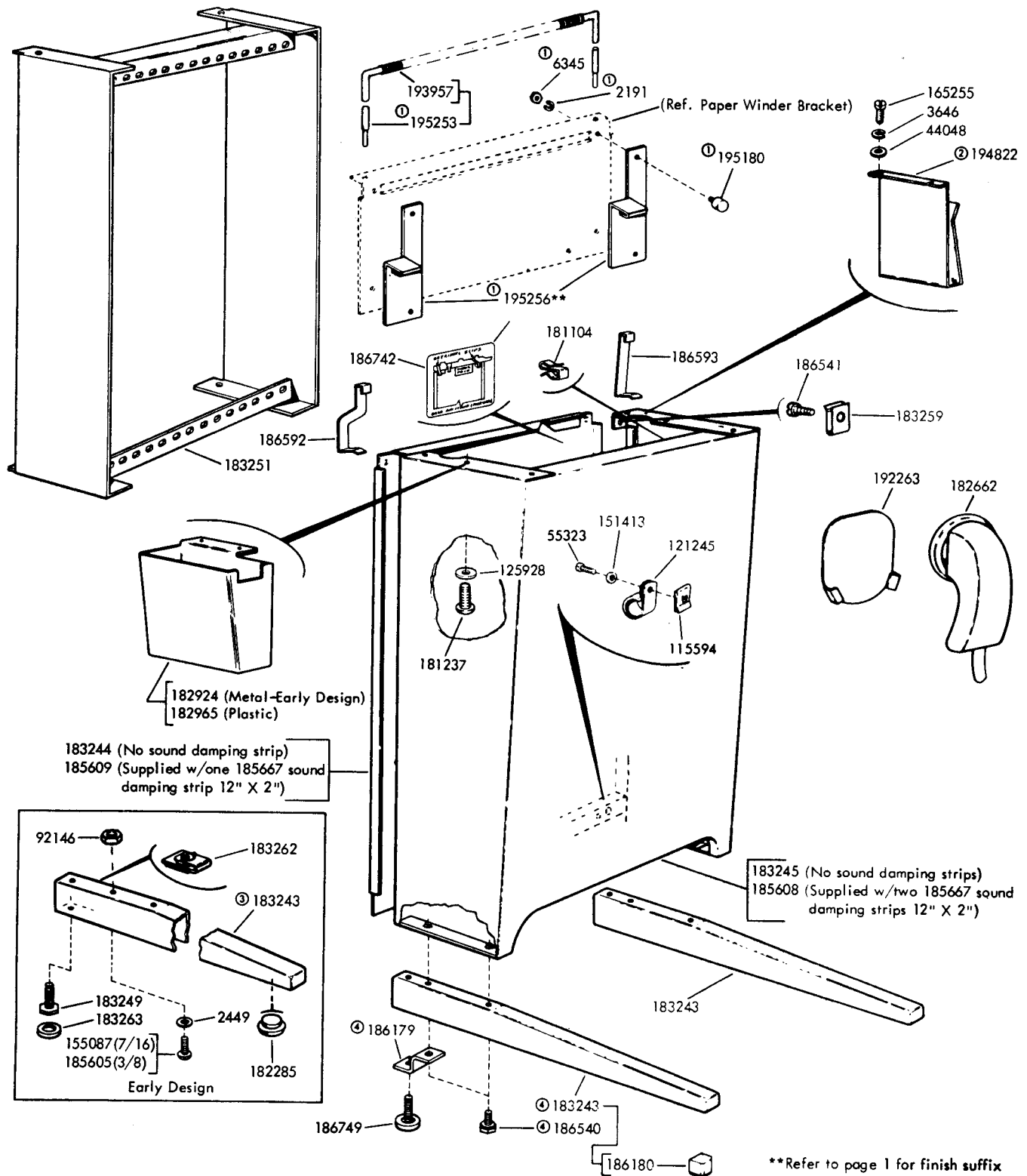

FIGURE 5. COVER AND TAPE STORAGE BIN



① 195259** Modification Kit to add Paper Winder to Cabinet

② The 194822 Directory Holder has been changed by including two 6 inch strips of double sided adhesive backed tape, eliminating the need for mounting hardware.

③ The Early Design 183243 Foot w/Brackets is no longer available. When replacing an Early Design Foot w/Brackets, order the 186203 Set of Parts.

④ 186203 Set of Parts to provide replacement Foot w/Bumper

**Refer to page 1 for finish suffix

FIGURE 6. CABINET

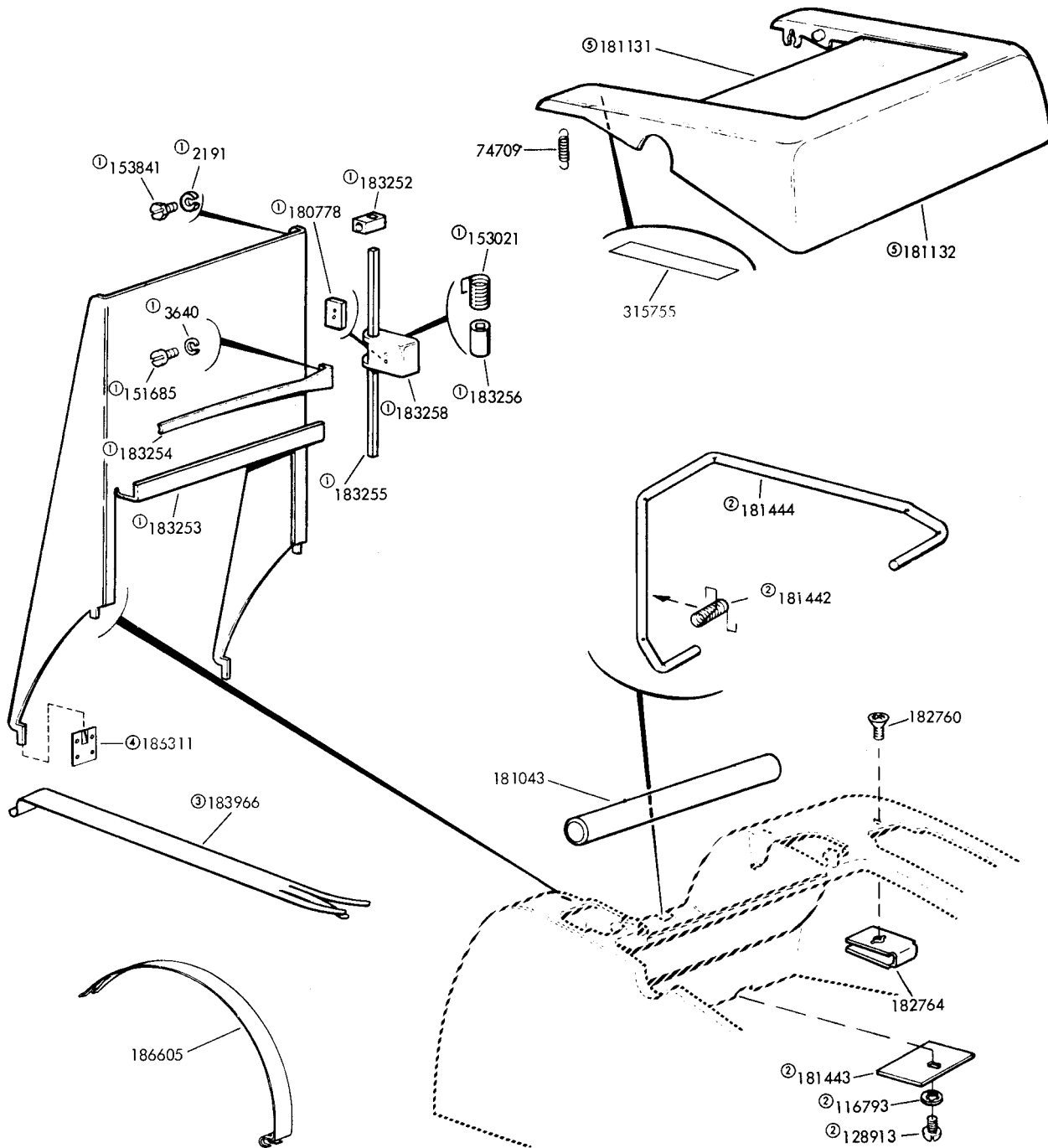

- ① 182036 Copyholder Assembly
- ② Used with Sets having Low Paper Alarm
- ③ No longer available. Order 186605 Paper Deflector
- ④ 186312 SOP to Provide Cover Repair Bracket for Copyholder

⑤ The 181131 Lid Window has been redesigned by adding nine holes to enable heat staking to the Lid rather than cementing as on the Early Design. Early and Late Design Lids w/ Window are interchangeable. If however, a Late Design Lid w/Window needs a replacement Window, a 181132 Lid w/Window must be ordered.

FIGURE 7. LID AND COPYHOLDER

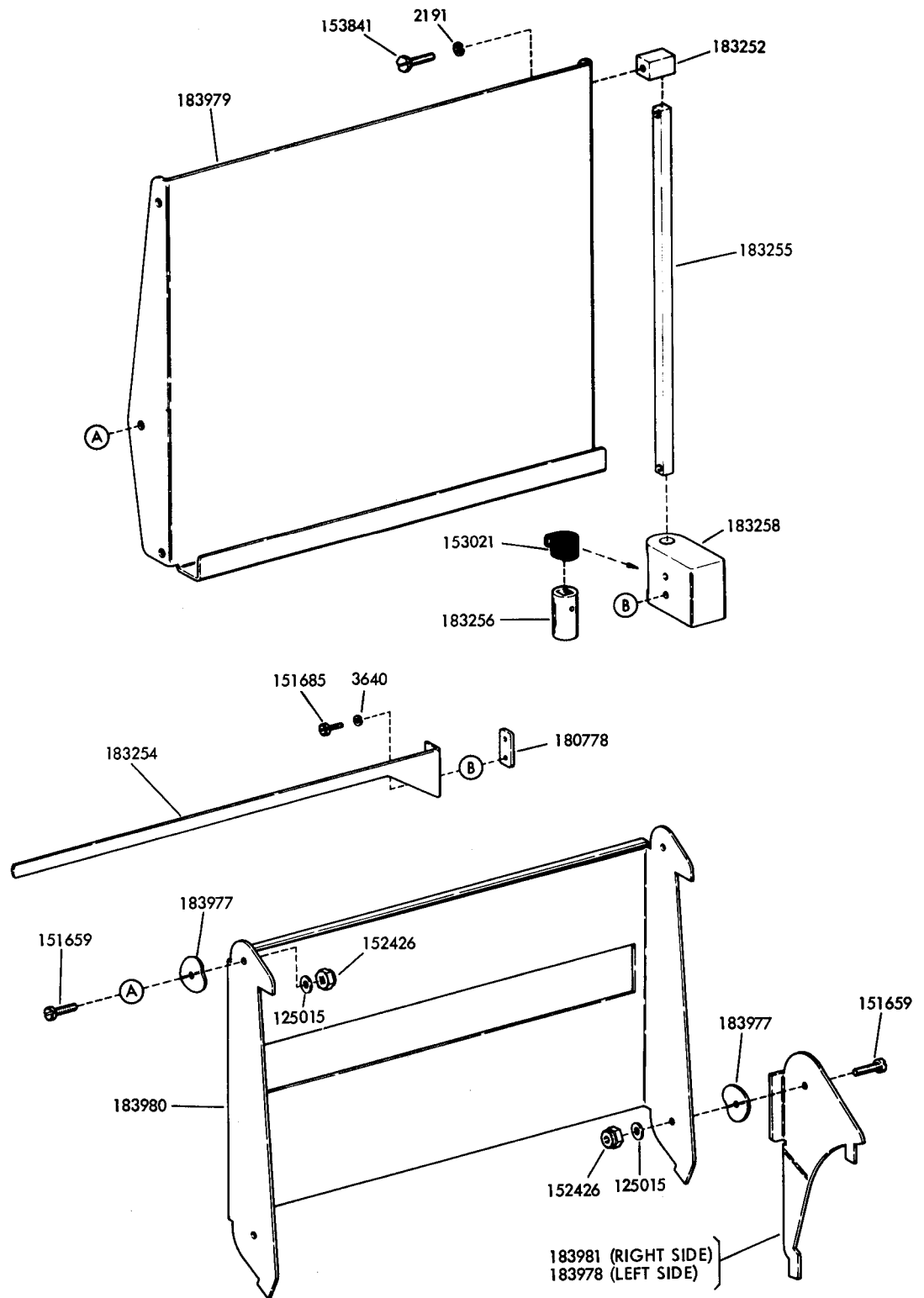

FIGURE 8. 183976 ADJUSTABLE COPYHOLDER ASSEMBLY

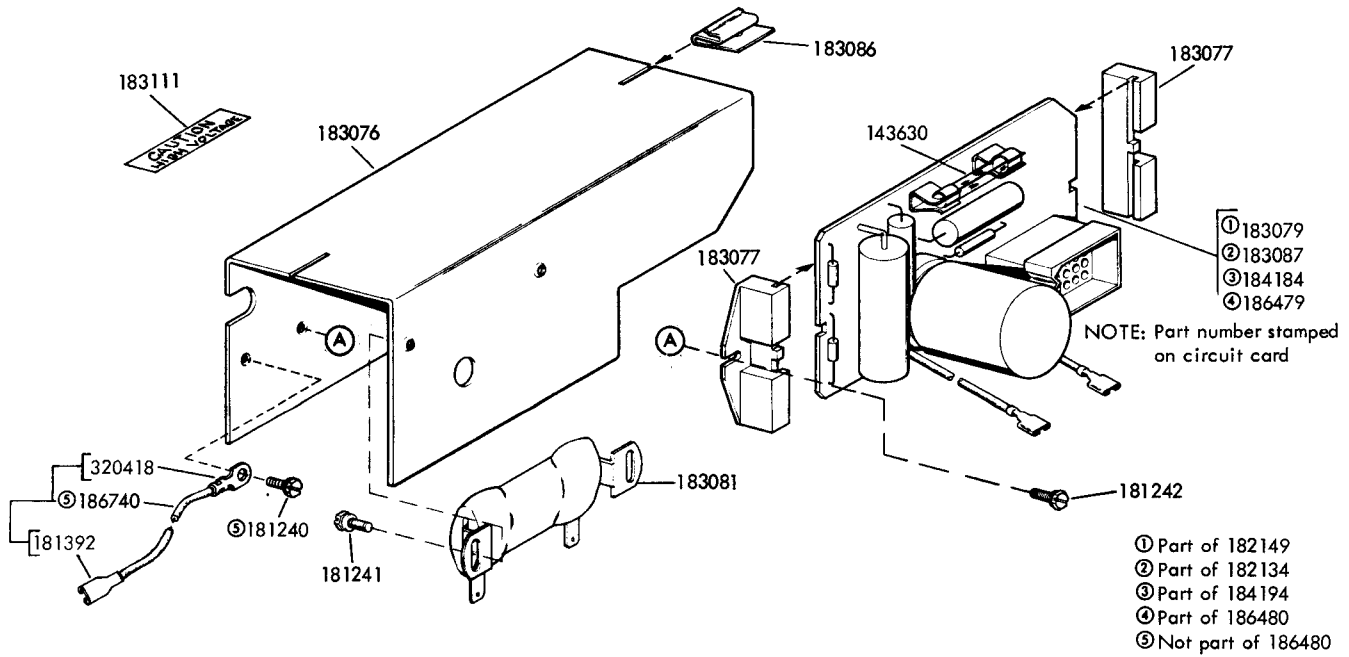

FIGURE 9. 182134, 182149, 184194 AND 186480 POWER PACK ASSEMBLIES

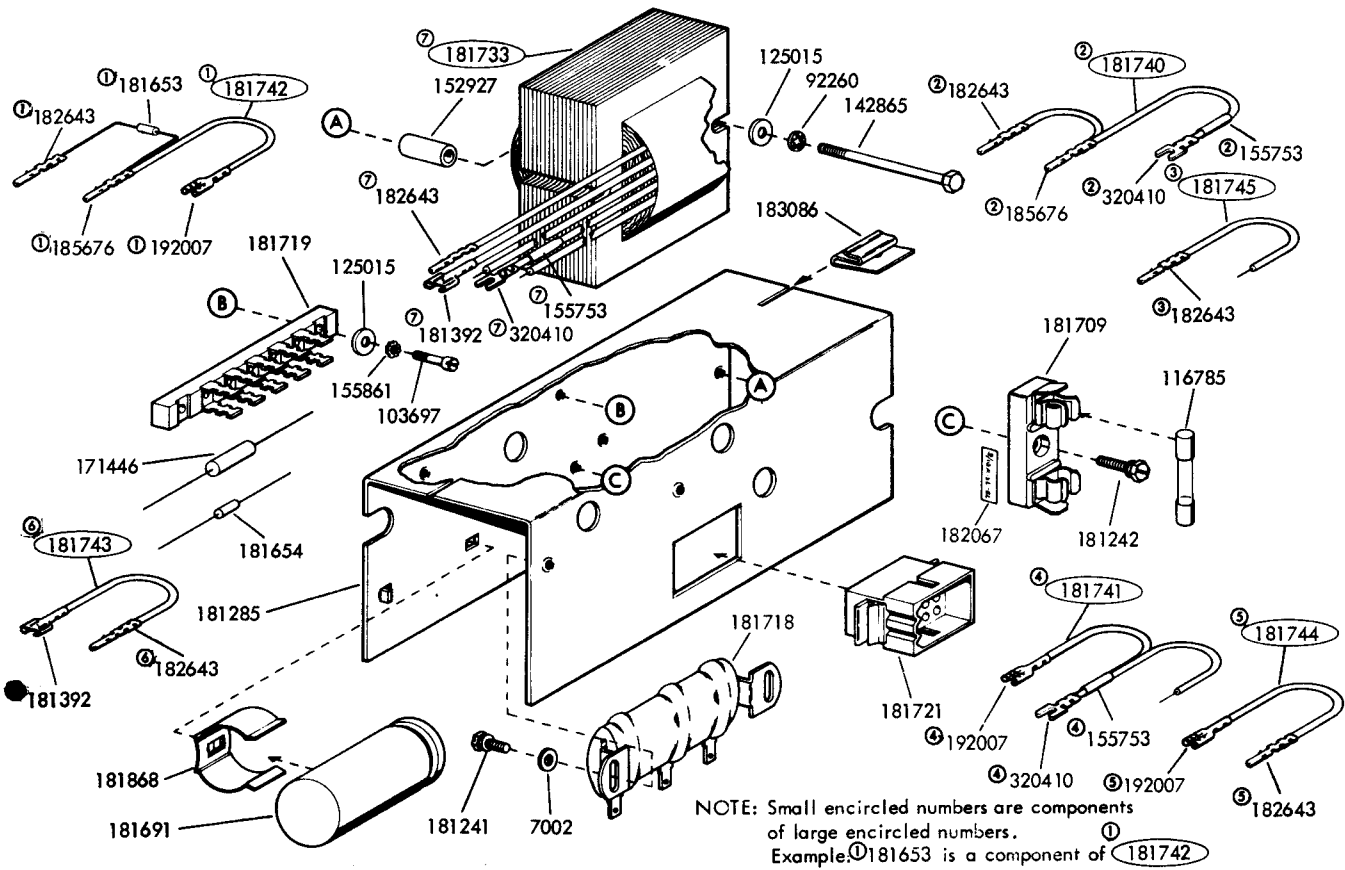

FIGURE 10. 181720 POWER PACK ASSEMBLY

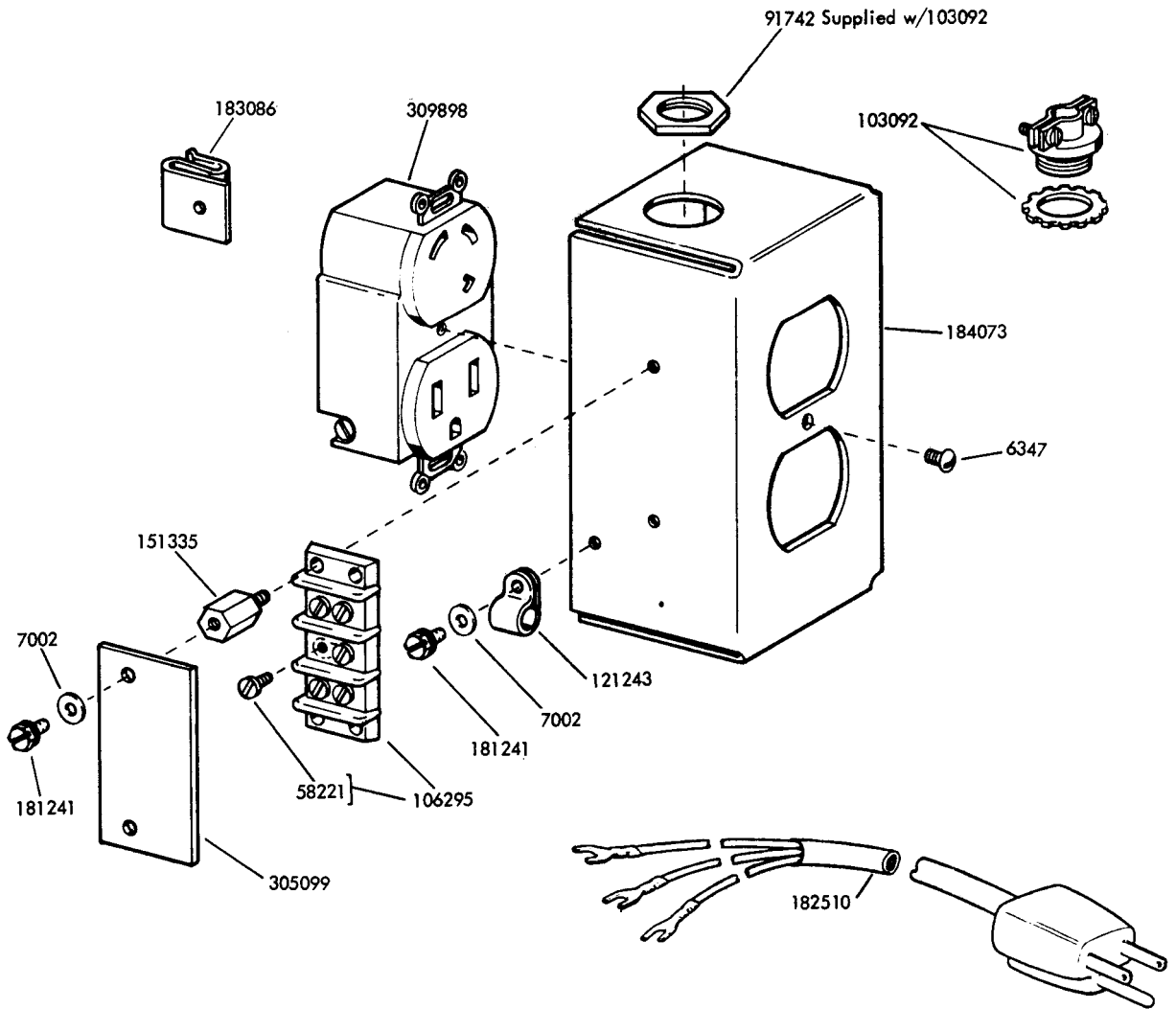
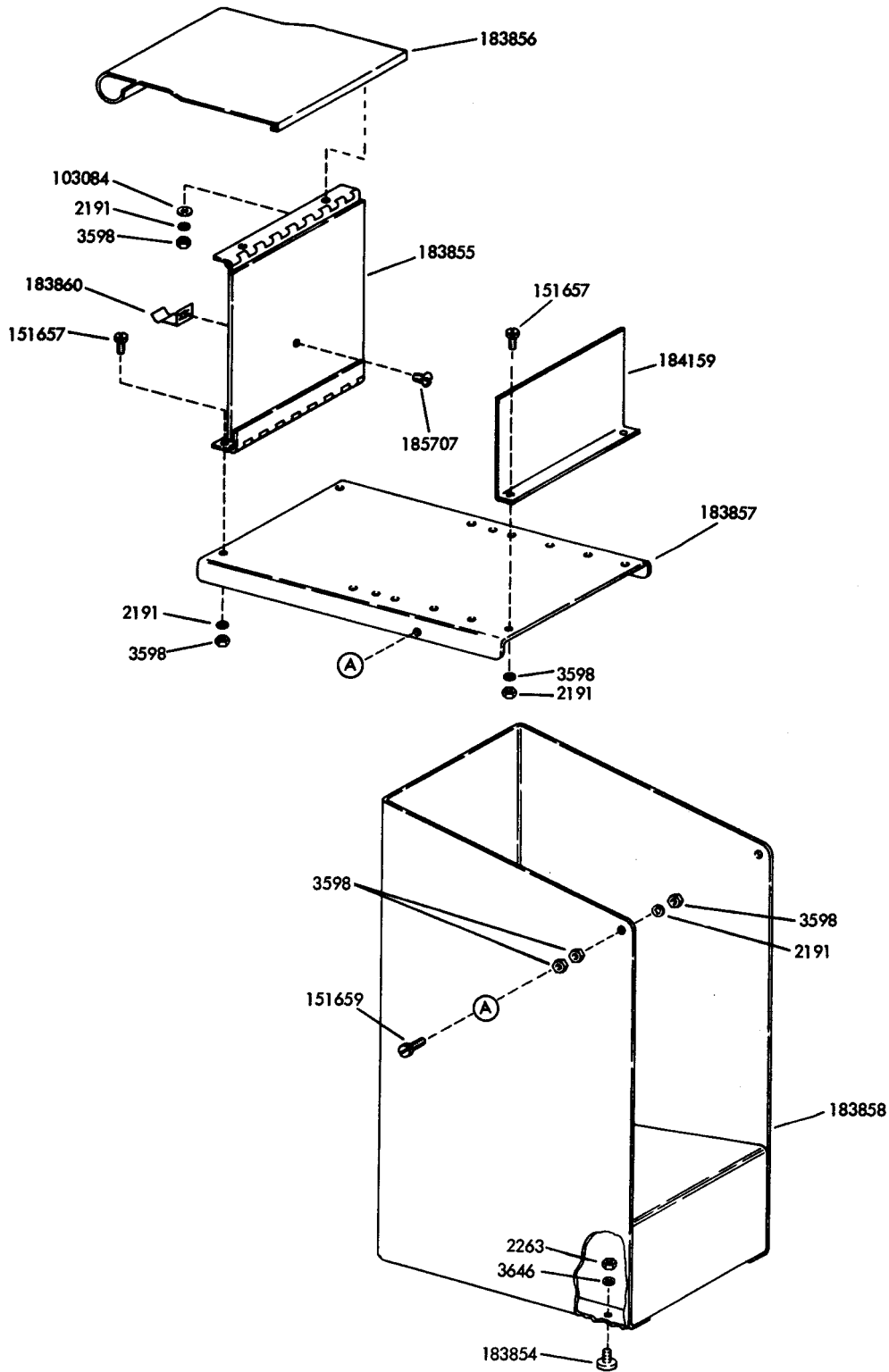

FIGURE 11. 184074 OUTLET BOX ASSEMBLY



Specification 504335

FIGURE 12. 183859 MODIFICATION KIT TO PROVIDE PAPER SUPPLY AND ACCUMULATING SHELF

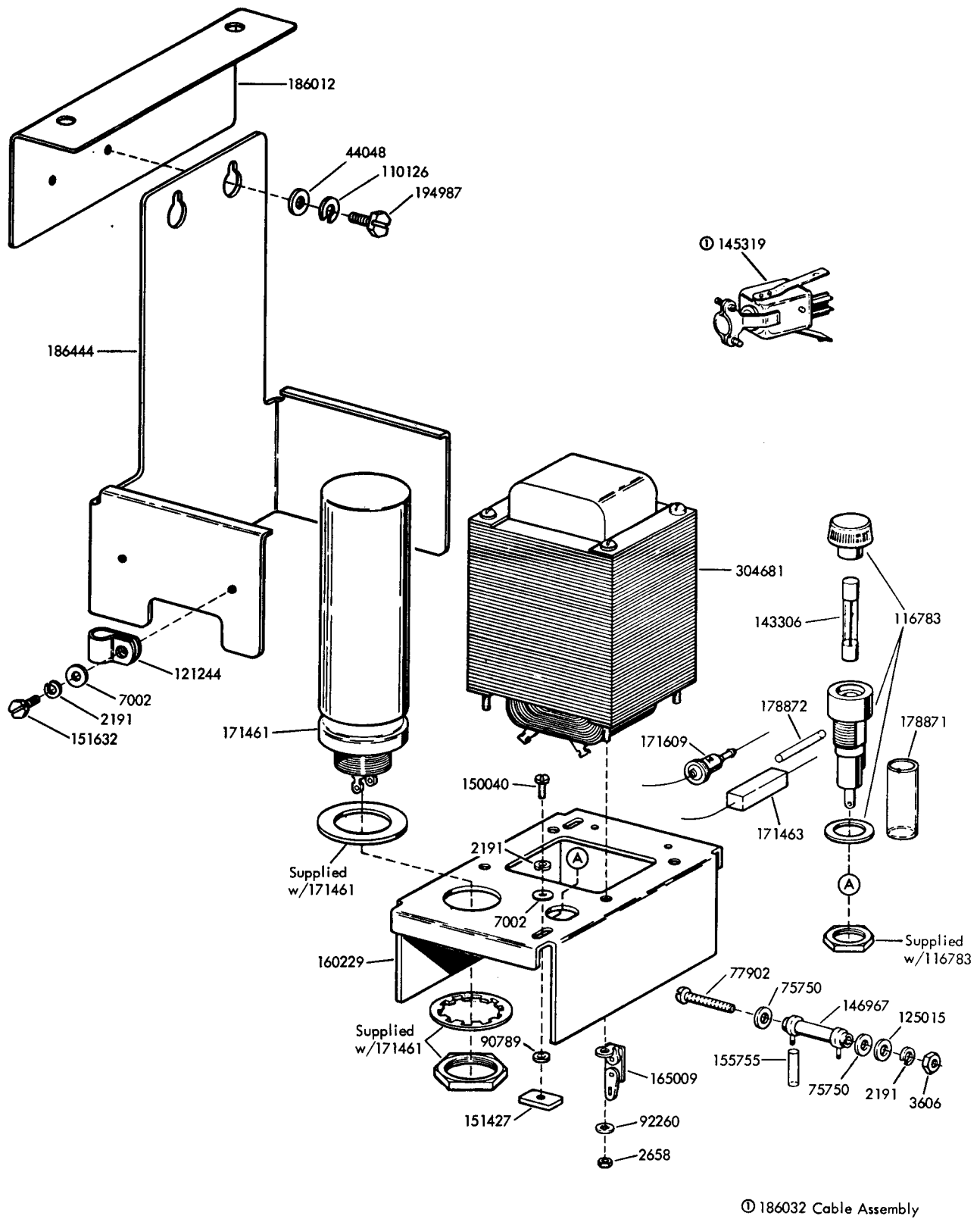
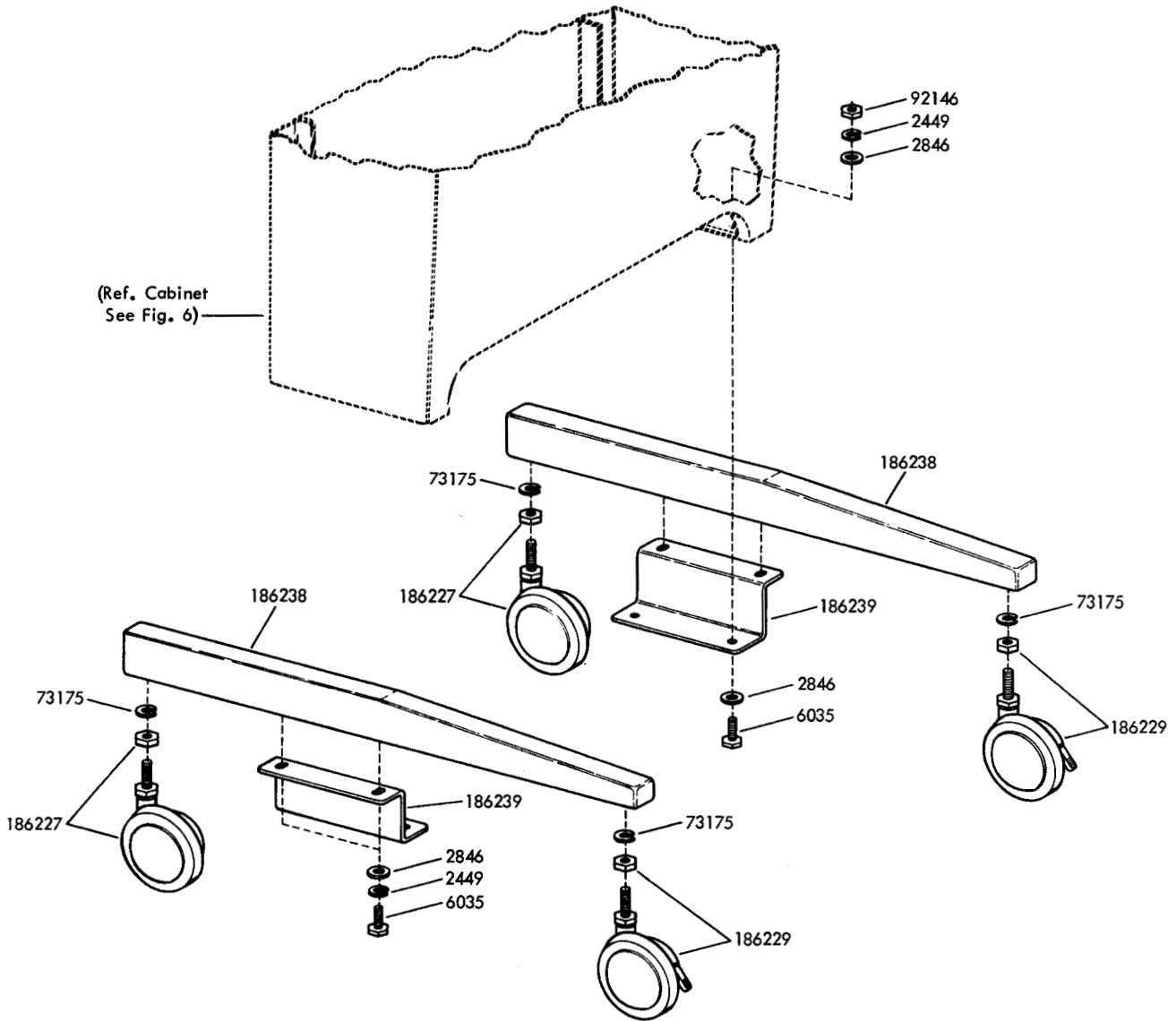

FIGURE 13. 186031 RECTIFIER ASSEMBLY



Specification 50626S

FIGURE 14. 186226 MODIFICATION KIT TO PROVIDE MOBILITY FOR CABINET

NUMERICAL INDEX

Part Number	Description and Page Number	Part Number	Description and Page Number	Part Number	Description and Page Number
2191	Lockwasher 6,7,8,9,12,13	143630	Fuse, .75 Amp 10	181043	Spindle, Paper Roll 8
2263	Nut, 8-32 Hex 12	145319	Receptacle, 4 Pt Plug 13	181104	Clip, Cable 7
2449	Lockwasher 7,14	146967	Resistor, 750 Ohm 13	181131	Window, Lid 8
2658	Nut, 6-32 Hex 13	147811	Spacer, .250" Thk 6	181132	Lid w/Window 8
2846	Washer, Flat 14	147812	Frame, Tape Bin 6	181133	Cover 2
3598	Nut, 6-40 Hex 3,4,12	147813	Window, Left Side 6	181135	Nameplate 2
3606	Nut, 6-40 Hex 13	147814	Window, Right Side 6	181137	Nameplate 2
3640	Lockwasher 8,9	147815	Divider, Tape Bin 6	181139	Label, Designation (Bell) 2
3646	Lockwasher 7,12	147816	Plate, Retaining 6	181140	Label, Designation (W.U.) 2
6035	Screw, 1/4-20 x 5/8 Hex 14	147817	Guide, Tape Bin 6	181141	Screw, 8-32 Spl 2
6345	Nut, 6-32 Hex 7	150040	Screw, 6-40 5/8 Fil 13	181148	Nameplate 2
6347	Screw, 6-32 x 3/8 Rd 11	151335	Stud 11	181237	Screw, 1/4-14 Self- Tapping 7
7002	Washer, Flat 4,6,10,11,13	151413	Washer, Flat 7	181240	Screw w/Lockwasher, 6-40 x 3/16 Hex 10
44048	Washer, Flat 13	151427	Plate, Clamp 13	181241	Screw w/Lockwasher, 6-40 x 1/4 Hex 10,11
55323	Screw, 8-32 x 1/2 Rd 7	151632	Screw, 6-40 x 3/8 Hex 13	181242	Screw w/Lockwasher, 6-40 x 5/16 Hex 10
58221	Screw, 6-32 x 1/4 Fil 11	151657	Screw, 6-40 x 1/4 Fil 6,12	181244	Screw w/Lockwasher, 6-40 x 7/16 Hex 3
73175	Lockwasher 14	151659	Screw, 6-40 x 1/2 Fil 9,12	181245	Screw w/Lockwasher, 6-40 x 1/2 Hex 4
74709	Spring 8	151685	Screw, 4-40 x 5/16 Fil 8,9	181285	Cover, Mounting 10
75750	Washer, Insulating 13	152426	Nut, 6-40 Self-Locking 9	181287	Holder, Card 5
77902	Screw, 6-40 x 2-3/8 Rd 13	152927	Bushing 10	181288	Label, White 5
90789	Washer, Flat 13	153021	Spring, Torsion 8,9	181289	Window, Plastic 5
91742	Nut, Lock 11	153441	Screw, 10-32 x 7/16 Hex 4	181292	Window, Plastic 5
92146	Nut, 1/4-20 Hex 7,14	153538	Screw, 6-40 x 7/16 Hex 4	181392	Terminal, Tab Type 10
92260	Lockwasher 10,13	153841	Screw, 6-40 x 9/16 Hex 8,9	181442	Spring, Torsion 8
103084	Washer, Flat 12	155087	Screw, 1/4-20 x 7/16 Rd 7	181443	Plate, Clamp 8
103092	Connector, Cord 11	155753	Sleeve, 1/8 ID x 1/2" Lg Insulating 10	181444	Rod, Sensing 8
103697	Screw, 4-40 x 7/16 Fil 10	155755	Sleeve, 11/64 ID x 5/8" Lg Insulating 13	181653	Diode 10
106295	Block, Terminal 11	155861	Lockwasher 10	181654	Diode 10
107116	Lockwasher 6	160229	Plate, Mounting 13	181691	Capacitor, 150 MFD 10
110126	Lockwasher 13	165009	Terminal 13	181709	Holder, Fuse 10
115594	Nut, Speed 7	165255	Screw, No. 8 Spl 7	181718	Resistor, 2,000 - 10,000 Ohms 10
116783	Holder, Fuse 13	171446	Resistor, 120 Ohm 10	181719	Strip, Terminal 10
116785	Fuse, .3 Amp 10	171461	Capacitor, 900 MFD 13	181720	Power Supply 1,10
116793	Lockwasher 8	171463	Resistor, 1 Ohm 13	181721	Connector, 12 Pt Plug Type 10
119634**	Button, Plug 5	171609	Diode 13	181733	Transformer 10
119649	Ring, Retaining 4	178871	Sleeve, 1/2 ID x 1-1/8" Lg Insulating 13	181740	Cable Assembly 10
121243	Clamp, 3/16" ID Cable 11	178872	Sleeve, 1/16 ID x 1-1/4" Lg Insulating 13	181741	Cable Assembly 10
121244	Clamp, 1/4 ID Cable 13	180714	Screw, No.6 Self- Tapping 6	181742	Cable Assembly 10
121245	Clamp, 5/16" ID Cable 7	180778	Plate 8,9	181743	Cable Assembly 10
124177	Lockwasher 3,4	180798	Screw, 8-32 Self- Tapping 3	181744	Cable Assembly 10
125015	Washer, Flat 3,4,9,10,13				
125928	Washer, Flat 7				
128913	Screw, 8-32 Self- Tapping 8				
129098	Screw, 6-40 x 11/32 Flat 6				
142865	Screw, 6-40 x 2-1/32 Hex 10				
143306	Fuse, SL-BL 1 Amp 13				

**Refer to page 1 for finish suffix

NUMERICAL INDEX (Continued)

Part Number	Description and Page Number	Part Number	Description and Page Number	Part Number	Description and Page Number
181745	Cable Assembly 10	183076	Bracket, Rectifier 10	183980	Link 9
181812	Nameplate 2	183077	Clamp, Circuit Card 10	183981	Bracket, Right 9
181868	Clip, Speed 10	183079	Card, Circuit 10	184006	Screw, 8-32 Self-Tapping 4
181900	Cover 2	183081	Resistor, 850 Ohm 10	184035	Label, Designation 2
181901**	Faceplate 5	183086	Clip 10,11	184073	Bracket, Outlet 11
181902**	Faceplate 5	183087	Card, Circuit 10	184074	Box Assembly, Outlet 1,11
181903**	Faceplate 5	183091	Post 4	184085	Screw, 8-32 Thumb 2
181904**	Faceplate 5	183092	Cup 4	184159	Bracket, Back Stop 12
181909**	Faceplate 5	183094	Plate w/Studs 4	184184	Card, Circuit 10
181910**	Faceplate 5	183111	Label 10	184194	Power Pack 1,10
181914**	Faceplate 5	183112	Screw, 4-40 x 9/64 Fil 4	184206	Lid Assembly 3
181921**	Faceplate 5	183117	Screw, 10-32 x 5/8 Hex 4	184208	Spring 3
181922**	Faceplate 5	183118	Plate, Clamp 4	185605	Screw, 1/4-14 Self-Tapping 7
181931	Faceplate 5	183125	Label 2	185608	Cabinet 7
182036	Copyholder Assembly 8	183133	Bracket 4	185609	Panel 7
182067	Nameplate 10	183134	Base 4	185667	Strip, Damping 7
182109	Lid Assembly 3	183135	Cover 4	185676	Terminal, Plug Type 10
182134	Power Pack 1,10	183138	Modification Kit 4	185700	Base 4
182149	Power Pack 1,10	183140	Cover 4	185707	Screw, 10-24 x 5/16 Rd 12
182278	Support 2	183141	Holder, Card 5	185815	Nameplate 2
182285	Bumper, Rubber 7	183243	Foot w/Bumper 7	186012	Bracket 13
182468	Lid 3	183244	Panel 7	186031	Rectifier Assembly 1,13
182510	Cord, Power 11	183245	Cabinet, Lower 6,7	186032	Cable Assembly 13
182643	Terminal, Plug Type 10	183249	Screw, 5/16-18 Spl 7	186054	Nameplate 2
182662	Receiver 7	183251	Rack 7	186055	Nameplate 2
182760	Screw, 6-32 Spl 5,8	183252	Post 8,9	186056	Nameplate 2
182764	Nut, Speed 5,8	183253	Copyholder 8	186057	Nameplate 2
182912	Lid 3	183254	Guide, Line 8,9	186179	Bracket 7
182913	Base, Cover 3	183255	Shaft 8,9	186180	Bumper, Rubber 7
182916	Screw, 8-32 x 2-9/16 Hex 3	183256	Bushing 8,9	186202	Shield 2
182917	Spring, Special 3	183258	Handle, Copyholder 8,9	186203	Set of Parts 7
182918	Spindle 3	183259	Nut, Speed 7	186208	Cover 2
182919	Button 3	183260	Nut, Speed 6	186226	Modification Kit 1,14
182921	Cover, Right 3	183262	Retainer, Nut 7	186227	Caster 14
182922	Cover, Left 3	183263	Cap, Light Gray 7	186229	Caster w/Brake 14
182924	Box, Chad 7	183501	Cover, Stand 6	186238	Foot 14
182926	Cover Assembly 3	183508**	Faceplate 5	186239	Bracket 14
182927	Cover 2	183513	Cover 2	186311	Bracket 8
182928	Cover 2	183854	Foot 12	186312	Set of Parts 8
182932	Nut, Speed 3	183855	Plate w/Hinges 12	186444	Bracket 13
182935	Hub 3	183856	Guide, Paper 12	186479	Card, Circuit 10
182965	Box, Chad 7	183857	Shelf, Paper 12	186480	Power Pack 1,10
183025	Bracket 4	183858	Bin, Paper Supply 12	186540	Screw, 1/4-20 x 1/4 Spl 7
183045	Cover 4	183859	Modification Kit 1,12	186541	Screw, No.8 x 1/2 Spl 7
183046	Cover 4	183860	Clip, Spring 12	186592	Clip 7
183047	Base 4	183966	Deflector, Paper 8	186593	Clip 7
183067	Shield 4	183976	Copyholder Assembly 1,9	186598**	Faceplate 5
183068	Spring, Shield 4	183977	Washer, Spring 9	186599**	Faceplate 5
183070	Grommet, Rubber 4	183978	Bracket, Left 9		
		183979	Copyholder 9		

**Refer to page 1 for finish suffix

NUMERICAL INDEX (Continued)

Part Number	Description and Page Number	Part Number	Description and Page Number	Part Number	Description and Page Number
186605	Deflector, Paper 8	194822	Holder, Directory 7	304681	Transformer 13
186740	Jumper, 6" Green 10	194987	Screw, 8-32 x 3/8 Hex 13	305099	Cover, Insulating 11
186742	Label 7	185180	Bumper, Rubber 7	309898	Outlet, Duplex 11
186749	Bolt w/Cap 7	195253	Rack Assembly, Display 7	315755	Label 8
192007	Terminal, Tab Type 10	195256**	Hanger 7	320410	Terminal, Spade Type 10
192263	Holder, Handset 7	195259**	Modification Kit 7	320418	Terminal, Ring Type 10
192289	Screw, 1/4-14 Self-Tapping 6	197028	Terminal 6	323129**	Faceplate 5
193957	Spring, Roller 7	199931	Bin Assembly, Tape Storage 6	328738**	Faceplate 5

**Refer to page 1 for finish suffix

