

TEMPLE

~~SECRET~~

Digital Equipment Corporation
Maynard, Massachusetts

digital

RK05 DISK DRIVE MAINTENANCE MANUAL

RK05
DISK DRIVE
MAINTENANCE MANUAL

Copyright © 1972 by Digital Equipment Corporation

The material in this manual is for informational purposes and is subject to change without notice.

The following are trademarks of Digital Equipment Corporation, Maynard, Massachusetts:

DEC	PDP
FLIP CHIP	FOCAL
DIGITAL	COMPUTER LAB

RK05 DISK DRIVE

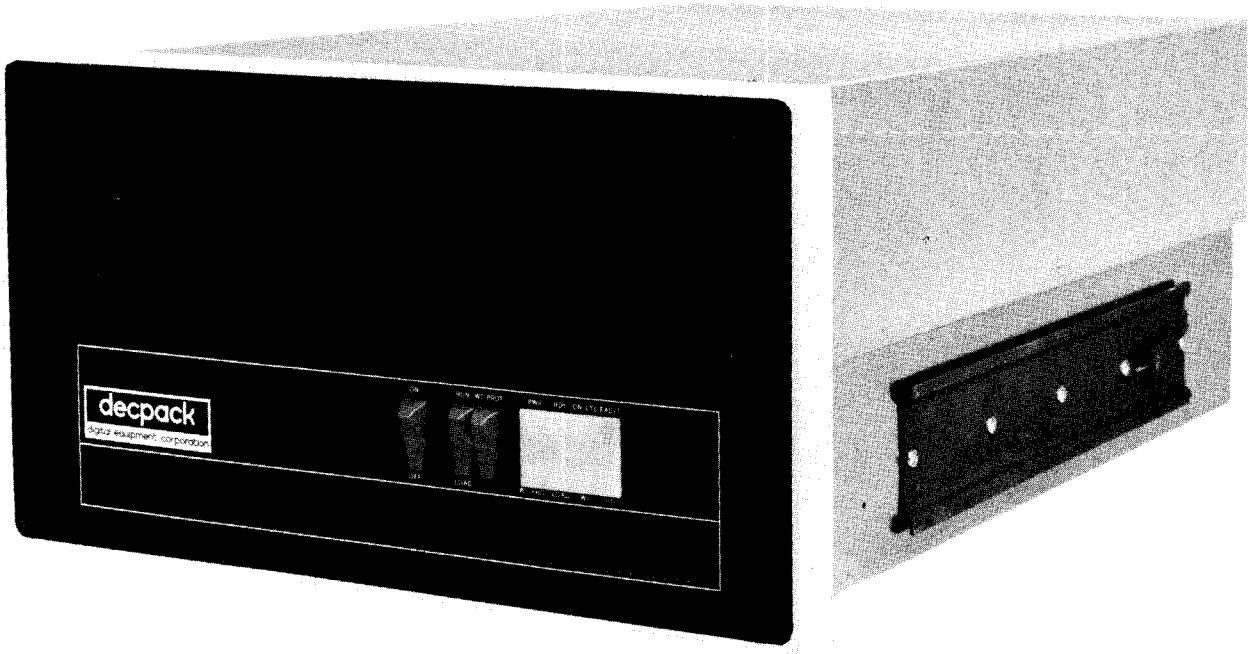

RK05 Disk Drive

CONTENTS

	Page
CHAPTER 1 GENERAL INFORMATION	
1.1	Introduction 1-1
1.2	Specifications 1-1
1.3	50/60 Hz Power Option 1-2
1.4	Major Assemblies and Systems 1-3
1.4.1	Controls and Indicators 1-4
1.4.2	Spindle and Drive 1-6
1.4.3	Linear Positioner 1-7
1.4.4	Cartridge Handling System 1-7
1.4.5	Electronic Module 1-9
1.4.6	Air System 1-9
1.4.7	Power Supply 1-9
CHAPTER 2 INSTALLATION	
2.1	Unpacking and Inspection 2-1
2.2	Mechanical Installation and Checkout 2-1
2.3	Operation 2-3
2.3.1	Disk Cartridge Installation and Removal 2-3
2.3.2	Normal Operating Procedure 2-3
CHAPTER 3 INTERFACE	
3.1	General 3-1
3.2	Input Interface Lines 3-1
3.2.1	Select (4 Lines) 3-1
3.2.2	Cylinder Address (8 Lines) 3-1
3.2.3	Strobe 3-1
3.2.4	Head Select 3-2
3.2.5	Write Protect Set 3-3
3.2.6	Write Data and Clock 3-3
3.2.7	Write Gate 3-3
3.2.8	Restore (RTZ) 3-3
3.2.9	Read Gate 3-3
3.3	Output Interface Lines 3-3
3.3.1	File Ready 3-3
3.3.2	R/W/S Ready (Read, Write, or Seek Ready) 3-3
3.3.3	Address Accepted 3-4
3.3.4	Address Invalid 3-4
3.3.5	Seek Incomplete 3-4
3.3.6	Write Protect Status 3-4
3.3.7	Write Check 3-4
3.3.8	Read Data 3-4
3.3.9	Read Clock 3-4

CONTENTS (Cont)

	Page
3.3.10	Sector Address (4 Lines) 3-4
3.3.11	Sector Pulse 3-5
3.3.12	Index Pulse 3-5
3.3.13	AC Low 3-5
3.3.14	DC Low 3-5
3.3.15	High Density 3-5
 CHAPTER 4 THEORY OF OPERATION	
4.1	Functional Description 4-1
4.1.1	Start 4-1
4.1.2	Stop 4-1
4.1.3	Track Addressing and Head Positioning 4-2
4.1.4	Read/Write Heads 4-4
4.1.5	Recording Technique 4-7
4.2	Logical Description 4-7
4.2.1	Power On/Off Sequence 4-7
4.2.2	Start 4-8
4.2.3	Stop 4-11
4.2.3.1	Normal Stop 4-11
4.2.3.2	Low Speed Stop 4-11
4.2.3.3	AC Low Stop 4-11
4.2.3.4	DC Low Stop 4-12
4.2.4	Disk Drive Addressing 4-12
4.2.5	Seek 4-12
4.2.5.1	Load Heads Seek 4-12
4.2.5.2	Forward Seek 4-13
4.2.5.3	Reverse Seek 4-14
4.2.5.4	Return-to-Zero (Restore) Seek 4-14
4.2.6	Position Servo Logic 4-15
4.2.6.1	Velocity Mode 4-16
4.2.6.2	Velocity Synthesizer 4-17
4.2.6.3	Detent Mode 4-19
4.2.7	Sector/Index Pulse Generation 4-19
4.2.8	Read Operation 4-21
4.2.9	Write Operation 4-23
4.2.10	Fault Detection 4-23
4.2.10.1	Erase Current Fault 4-24
4.2.10.2	Positioner Lamp Fault 4-24
4.3	Power Supply Description 4-24
 CHAPTER 5 MAINTENANCE	
5.1	Recommended Tools and Test Equipment 5-1
5.2	Preventive Maintenance 5-1

CONTENTS (Cont)

	Page	
5.2.1	Elapsed Time Indicator	5-2
5.2.2	500-Hour PM Procedure	5-3
5.2.3	1,500-Hour PM Procedure	5-3
5.2.4	3,000-Hour PM Procedure	5-4
5.2.5	Prefilter Removal and Replacement	5-4
5.2.6	Absolute Filter Removal and Replacement	5-4
5.3	Corrective Maintenance	5-5
5.3.1	Linear Positioner	5-5
5.3.1.1	Positioner Removal	5-5
5.3.1.2	Positioner Replacement	5-5
5.3.2	Carriage	5-7
5.3.2.1	Carriage Removal	5-7
5.3.2.2	Carriage Replacement	5-7
5.3.2.3	Carriage Bearing Assembly Removal	5-9
5.3.2.4	Carriage Bearing Assembly Replacement	5-9
5.3.2.5	Transducer Block Removal and Replacement	5-9
5.3.2.6	Servo System Timing Adjustment	5-11
5.3.3	Read/Write Heads	5-14
5.3.3.1	Head Removal	5-14
5.3.3.2	Head Replacement	5-14
5.3.3.3	Read/Write Head Alignment	5-15
5.3.3.4	Read/Write Data Separator (G180 Card) Adjustment	5-16
5.3.4	Spindle	5-18
5.3.4.1	Spindle Removal	5-18
5.3.4.2	Spindle Replacement	5-18
5.3.4.3	Sector Pulse Timing Adjustment	5-18
5.3.5	Spindle Drive Motor	5-20
5.3.5.1	Motor Removal	5-20
5.3.5.2	Motor Replacement	5-20
5.3.6	Drive Belt Removal and Replacement	5-20
5.3.7	Blower Motor	5-21
5.3.7.1	Blower Removal	5-21
5.3.7.2	Blower Replacement	5-22
5.4	Spare Parts List	5-23
5.5	Troubleshooting	5-24

ILLUSTRATIONS

Figure No.	Title	Page
1-1	Location of Major Assemblies and Systems	1-3
1-2	Controls and Indicators	1-4
1-3	Spindle and Drive System	1-6
1-4	Linear Positioner	1-7
1-5	Cartridge Handling System	1-8

ILLUSTRATIONS (Cont)

Figure No.	Title	Page
1-6	Air System	1-9
2-1	Chassis Slide Mounting	2-2
3-1	Controller-to-Disk Drive Interface Lines	3-2
4-1	Functional Block Diagram	4-2
4-2	Start Flow Chart	4-3
4-3	Stop Flow Chart	4-4
4-4	Seek Flow Chart	4-5
4-5	Return-to-Zero (Restore) Flow Chart	4-6
4-6	Head Loading	4-7
4-7	Read/Write Head	4-8
4-8	Simplified Read/Write Head Circuit	4-8
4-9	Double Frequency Pulse Relationship	4-9
4-10	Control and Interlock Block Diagram	4-10
4-11	Linear Position Transducer	4-16
4-12	Velocity Synthesizer Timing	4-18
4-13	Sector/Index Timing	4-20
4-14	Read Timing	4-22
5-1	Prefilter Removal	5-3
5-2	Absolute Filter Removal	5-5
5-3	Top View with Cover Removed	5-6
5-4	Bottom View with Covers Removed	5-6
5-5	Carriage Removal	5-8
5-6	Carriage Bearing Assembly Removal	5-10
5-7	Sine-Cosine Adjustment Waveforms	5-12
5-8	2-Cylinder Seek Waveform	5-13
5-9	64-Cylinder Seek Waveform	5-13
5-10	Position Offset Adjustment Waveform	5-14
5-11	Read/Write Head Adjustments	5-15
5-12	Read/Write Head Alignment Waveforms	5-17
5-13	Spindle Replacement	5-19
5-14	Blower Collar Removal	5-21
5-15	Blower Motor Removal	5-22

TABLES

Table No.	Title	Page
1-1	Performance Specifications	1-1
1-2	Controls and Indicators	1-4
5-1	Recommended Tools and Test Equipment	5-1
5-2	Preventive Maintenance Schedule	5-2
5-3	Spare Parts List	5-23

CHAPTER 1

GENERAL INFORMATION

1.1 INTRODUCTION

The RK05 Disk Drive is a self-contained, random-access, data storage device that is especially well suited for use in small or medium size computer systems, data acquisition systems, terminals, and other storage applications. Operational power for this device is provided by a power supply located within the drive cabinet. The RK05 is manufactured by Digital Equipment Corporation of Maynard, Massachusetts, and can be obtained in four different power models.

This compact light weight drive, uses a high density single disk cartridge, similar to the IBM 2315 disk cartridge, as its storage medium. Two movable heads, which fly above and below the rotating disk surface, can read or record up to 406 data tracks at 1500 rpm. The double frequency, nonreturn-to-zero (NRZ), recording method used in this drive, can store 24.4 million bits of on-line data. Data formatting is governed entirely by the operating system.

With the disk select logic contained in each drive, up to four RK05 Disk Drives can be "party-lined" and operated from a single controller bus.

1.2 SPECIFICATIONS

Table 1-1 lists the performance specifications of the RK05 Disk Drive.

Table 1-1
Performance Specifications

Characteristic	Specification
Storage Medium	
Type	Single-disk magnetic cartridge
Disk Diameter	14 inches
Magnetic Heads	
Number	Two
Recording Density and Format	
Density	2040 bpi, straddle erase
Tracks	406 (200 plus 3 spares on each side of the disk)
Cylinders	203 (two tracks each)
Sectors	4872 (12 per revolution)

(continued on next page)

Table 1-1 (Cont)
Performance Specifications

Characteristic	Specification
Bit Capacities (unformatted)	
Per Disk	24.4 million
Per Inch	2040 (max. at inner track)
Per Cylinder	120,000
Per Track	60,000
Per Sector	5,000
Access Times	
Disk Rotation	1500 ± 30 rpm
Average Latency	20 ms (half rotation)
Head Positioning	10 ms – for adjacent tracks
(including settling time)	50 ms – average
	85 ms – for 200 track movement
Bit Transfer	
Transfer Code	Double Frequency, Nonreturn-to-Zero Recording
Transfer Rate	1.44M bits per sec
Electrical Requirements	
Voltage	115/230 Vac @ 50/60 Hz
Power	250 VA
Starting Current	Power only: 1.8A Start spindle: 10A (for 2 sec)
Model Designation	
RK05AA	95 to 130 Vac @ 60 ± 0.5 Hz
RK05AB	190 to 260 Vac @ 60 ± 0.5 Hz
RK05BA	95 to 130 Vac @ 50 ± 0.5 Hz
RK05BB	190 to 260 Vac @ 50 ± 0.5 Hz
Environment	
Ambient Temperature	50° to 110°F (67° to 73°F nominal)
Relative Humidity	8% to 80% (no condensation)
Barometric Pressure	30 ± 3 mm hg
Dimensions and Weight	
Width	19 in.
Depth	26-1/2 in.
Height	10-1/2 in.
Weight	110 lb

1.3 50/60 Hz POWER OPTION

The RK05 Disk Drive is available in the following four power models:

- RK05AA 95 to 130 Vac @ 60 Hz
- RK05AB 190 to 260 Vac @ 60 Hz
- RK05BA 95 to 130 Vac @ 50 Hz
- RK05BB 190 to 260 Vac @ 50 Hz

Each model is shipped with a complete set of drawings. To change from 50 to 60 Hz operation requires a different spindle drive pulley. To change from 115 to 230V operation requires that the power connector (P2) be re-configured.

1.4 MAJOR ASSEMBLIES AND SYSTEMS

The RK05 Disk Drive is composed of the following major assemblies and systems:

- Controls and Indicators
- Spindle and Drive System
- Linear Positioner
- Cartridge Handling System
- Electronic Module
- Air System
- Power Supply

Figure 1-1 illustrates the locations, and the subsequent paragraphs describe the functions of each of the major assemblies and systems.

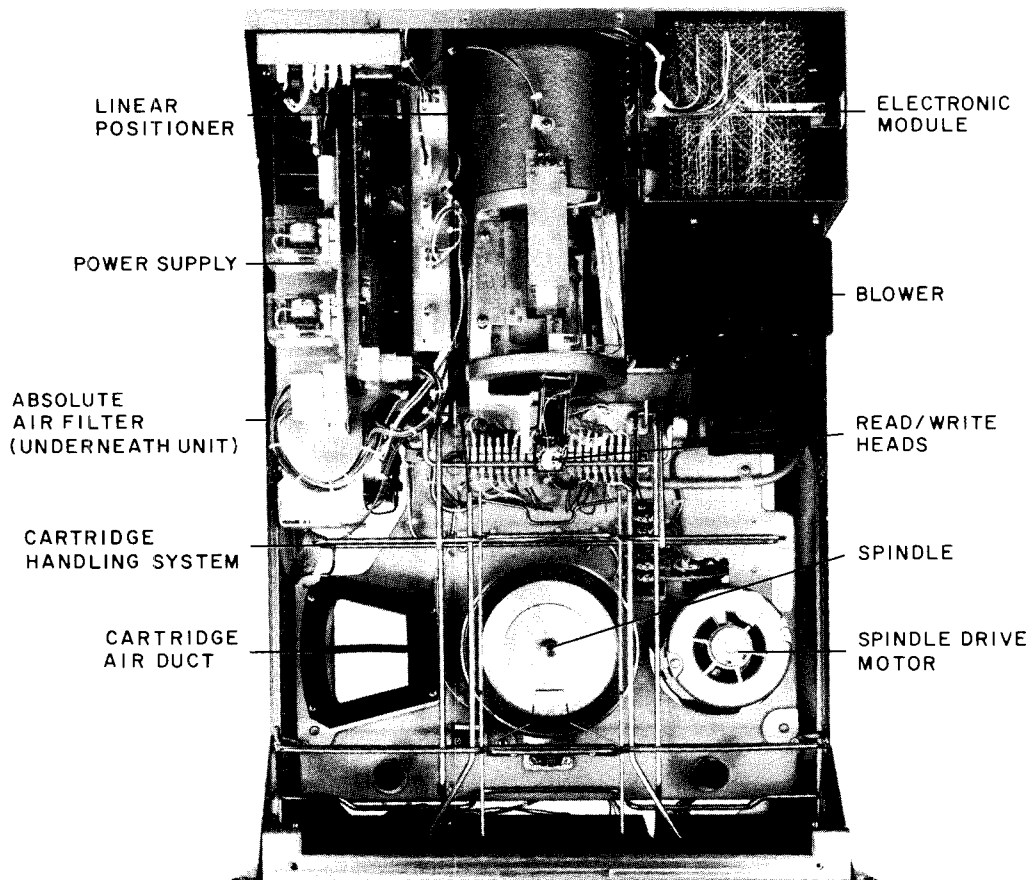

Figure 1-1 Location of Major Assemblies and Systems

1.4.1 Controls and Indicators

The controls and indicators (Figure 1-2) required for normal operation are located on the front of the drive cabinet. Table 1-2 describes the function of each control or indicator.

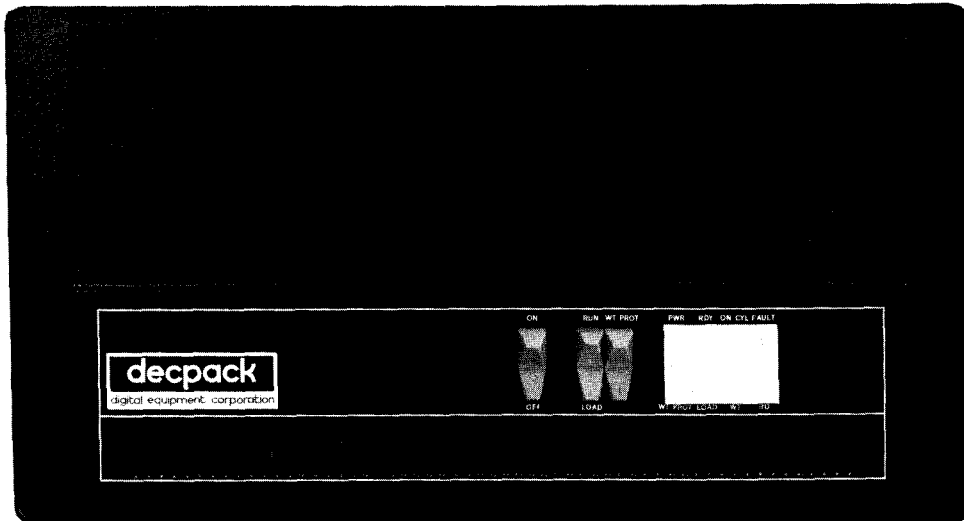

Figure 1-2 Controls and Indicators

Table 1-2
Controls and Indicators

Controls and Indicators	Description
ON/OFF (rocker switch)	Placing this switch in the ON position lights the PWR indicator and applies power to the drive.
	Placing this switch in the OFF position, turns off the PWR indicator and removes power from the drive.
RUN/LOAD (rocker switch)	Placing this switch in the RUN position (providing all interlocks are safe):
	<ul style="list-style-type: none"> a. locks the drive front door b. accelerates the disk to operating speed c. loads the read/write heads d. lights the RUN indicator
	Placing this switch in the LOAD position:
	<ul style="list-style-type: none"> a. unloads the read/write heads b. stops the disk rotation c. unlocks the drive front door d. lights the LOAD indicator <p style="text-align: center;">CAUTION</p> <p>Do not switch to the LOAD position during a write operation, as this results in erroneous data being recorded.</p>

(continued on next page)

Table 1-2 (Cont)
Controls and Indicators

Controls and Indicators	Description
<p>WT PROT (rocker switch – spring-loaded off)</p>	<p>Placing this momentary contact switch in the WT PROT position lights the WT PROT indicator and prevents a write operation as well as turns off the FAULT indicator, if lit.</p>
<p>PWR (indicator)</p>	<p>Placing this switch in the WT PROT position a second time turns off the WT PROT indicator and allows a write operation.</p>
<p>RDY (indicator)</p>	<p>Lights when operating power is present. Goes off when operating power is removed.</p> <p>Lights when:</p> <ol style="list-style-type: none"> a. the disk is rotating at the correct operating speed b. the heads are loaded c. no other conditions are present (all interlocks safe) to prevent a seek, read, or write operation
<p>ON CYL (indicator)</p>	<p>Goes off when the RUN/LOAD switch is set to the LOAD position.</p>
<p>ON CYL (indicator)</p>	<p>Lights when:</p> <ol style="list-style-type: none"> a. the drive is in the Ready condition b. a seek or restore operation is not being performed c. the read/write heads are positioned and settled
<p>FAULT (indicator)</p>	<p>Goes off during a seek or restore operation.</p> <p>Lights when:</p> <ol style="list-style-type: none"> a. erase or write current is present without a WRITE GATE or, b. the head position transducer lamp is inoperative,
<p>FAULT (indicator)</p>	<p>Goes off when the WT PROT switch is pressed or when the drive is recycled through a RUN/LOAD sequence.</p>
<p>WT PROT (indicator)</p>	<p>Lights when:</p> <ol style="list-style-type: none"> a. the WT PROT switch is pressed or, b. the operating system sends a Write Protect command.
<p>WT PROT (indicator)</p>	<p>Goes off when the WT PROT switch is pressed a second time or when the drive is recycled through a RUN/LOAD sequence.</p>
<p>LOAD (indicator)</p>	<p>Lights when the read/write heads are fully retracted and the spindle has stopped rotating.</p>
<p>LOAD (indicator)</p>	<p>Goes off when the RUN/LOAD switch is set to the RUN position.</p>
<p>WT (indicator)</p>	<p>Lights when a write operation occurs. Goes off when the write operation terminates.</p>
<p>RD (indicator)</p>	<p>Lights when a read operation occurs. Goes off when the read operation terminates.</p>

1.4.2 Spindle and Drive

The spindle and drive system (Figure 1-3) is composed of the spindle, spindle drive motor, and the recording disk. A 50/60 Hz, single-phase ac motor transfers torque (via the drive belt) to the spindle drive pulley. Belt tension is maintained by a tension spring anchored to the baseplate.

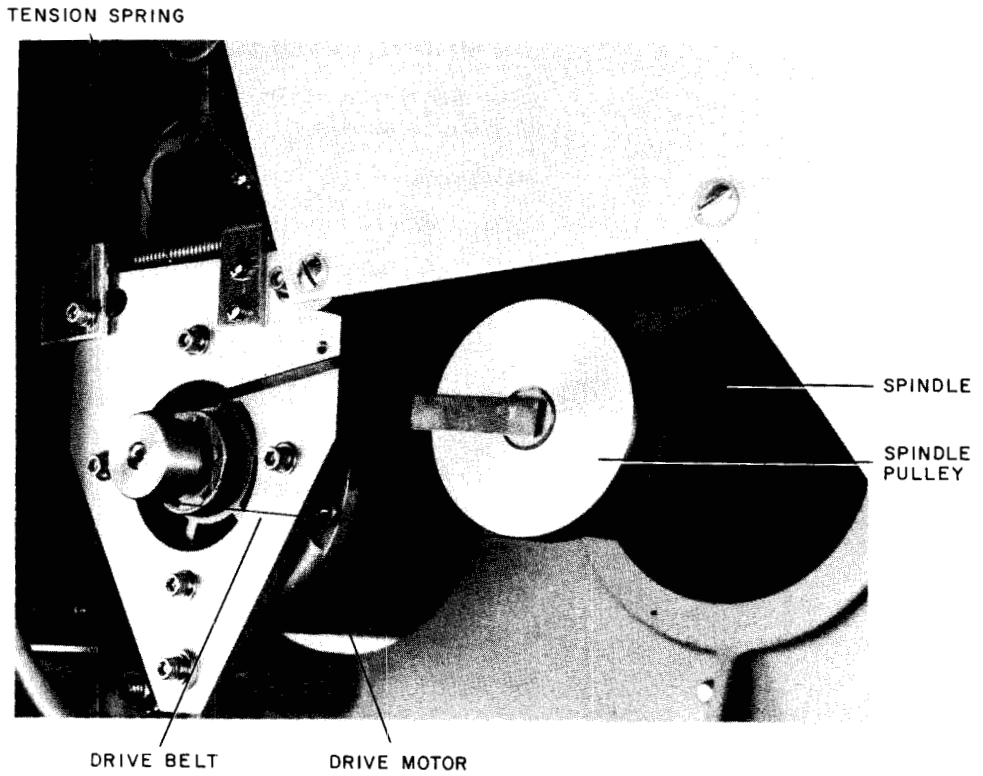

Figure 1-3 Spindle and Drive System

The spindle speed is electronically tested by a circuit that measures the INDEX PULSE interval. When the interval increases to approximately 45 ms, indicating an unsafe speed, the drive is cycled down. If the RUN/LOAD switch is placed in the LOAD position, ac power is removed from the motor and the spindle coasts to a halt.

1.4.3 Linear Positioner

The linear positioner (Figure 1-1) consists of the linear motor, the carriage, the read/write heads, and the optical position transducer. To move the read/write heads across the recording disk, dc current is applied to the bobbin-wound armature (Figure 1-4) of the linear motor. The resulting magnetic field reacts with a permanent magnet in the motor housing to either pull the armature into, or force it out of, the permanent magnetic field, depending upon the polarity of the current applied to the armature. This motion is transferred to the carriage, which is fastened to the armature. As a result, the read/write heads, which are attached to the carriage, move across the surface of the disk.

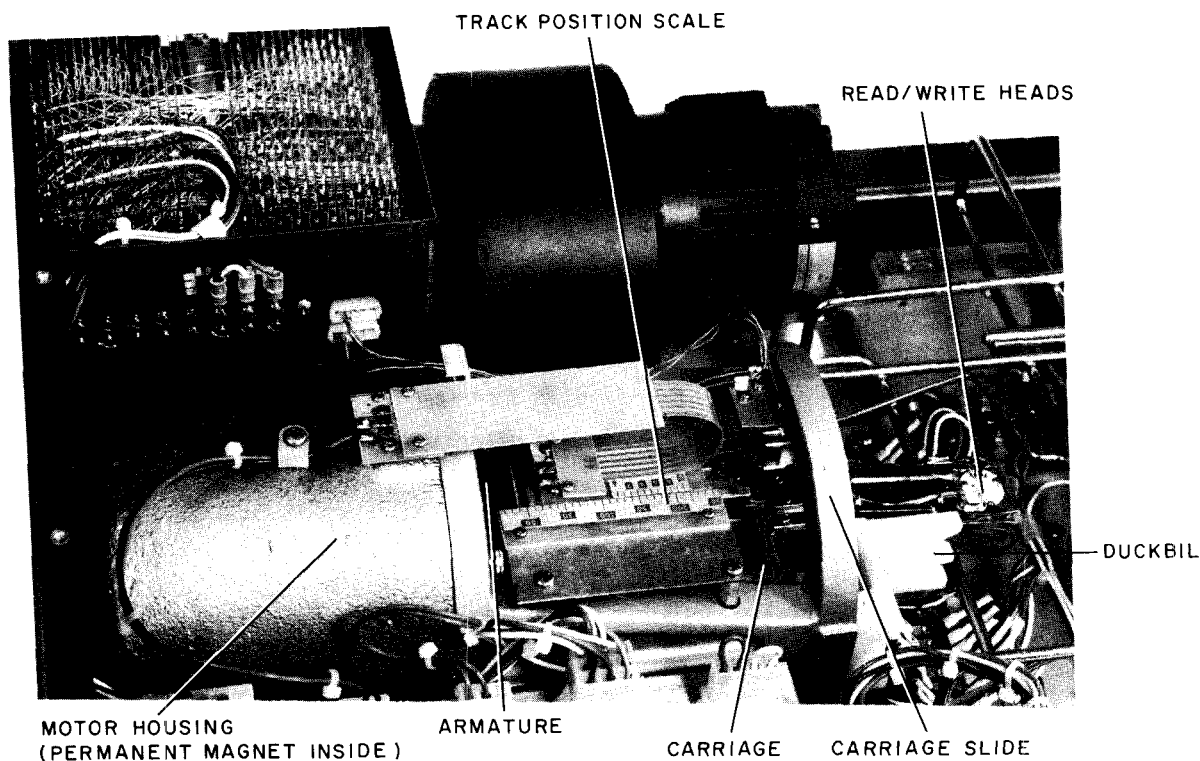
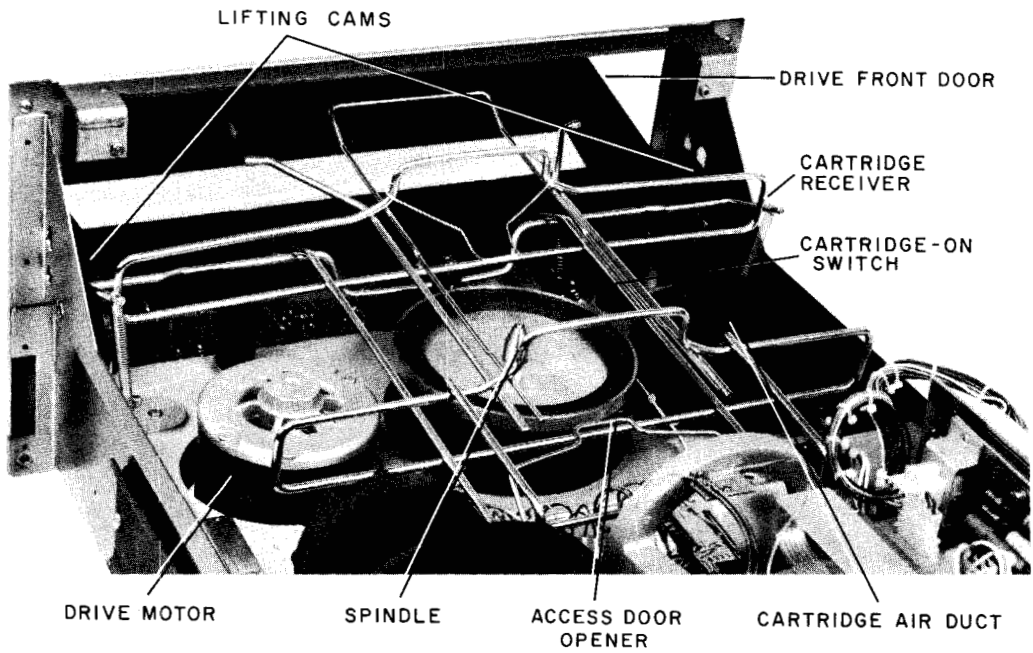

Figure 1-4 Linear Positioner

Any carriage movement is detected by the linear position transducer, which is located on the underside of the carriage. The transducer output is used with the control logic to determine the cylinder position of the heads, and in the servo logic to govern the speed of the carriage travel.

1.4.4 Cartridge Handling System

The cartridge handling system (Figure 1-5A) consists of a cartridge receiver, two receiver lifting cams, and an access door opener. During normal operation, the receiver supports the plastic cartridge case, allowing the recording disk to rotate freely on the spindle. The rotating spindle drives the disk by magnetic coupling at the disk hub.



a. Cartridge Removed

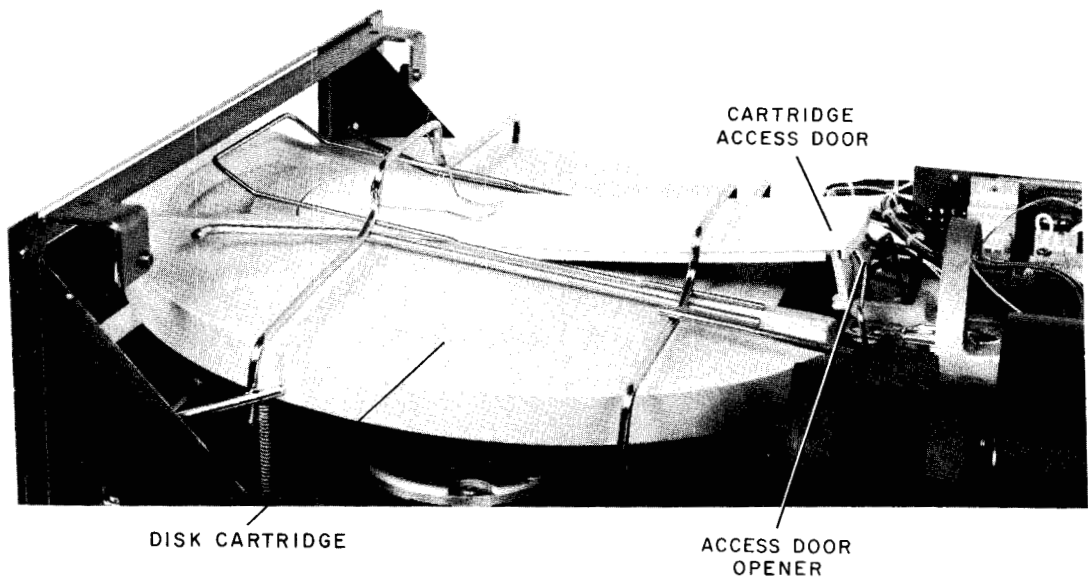

b. Cartridge Inserted

Figure 1-5 Cartridge Handling System

As the drive front door is closed, the cartridge is lowered to the operating position and the magnetic coupling again engages the disk hub. When the cartridge is in the operating position, the plastic case depresses the cartridge-on switch and removes the no-cartridge interlock condition.

1.4.5 Electronic Module

The electronic module (Figure 1-1), located in the right rear portion of the disk drive, holds eight printed circuit cards. Three of these cards contain the system logic and the read/write circuits. Two cards contain the position servo logic. One card is the cable connector that interfaces the electronics with the positioner and other chassis mounted components, while the remaining two cards contain the interface cables and terminators.

1.4.6 Air System

The air system (Figure 1-6) consists of the prefilter, blower, absolute filter, plenum chamber, and the cartridge air duct. As the blower rotates, unfiltered air is drawn through the prefilter, where it is purged of large dust particles. The prefiltered air is then circulated through the electronic module and into the plenum. From here, the air passes through the absolute filter (where minute contamination is removed), up the cartridge air duct, and into the disk cartridge. Cooling air from the absolute filter is also shunted, by the plenum, through the linear positioner. Exhaust air exits through the front grill of the drive.

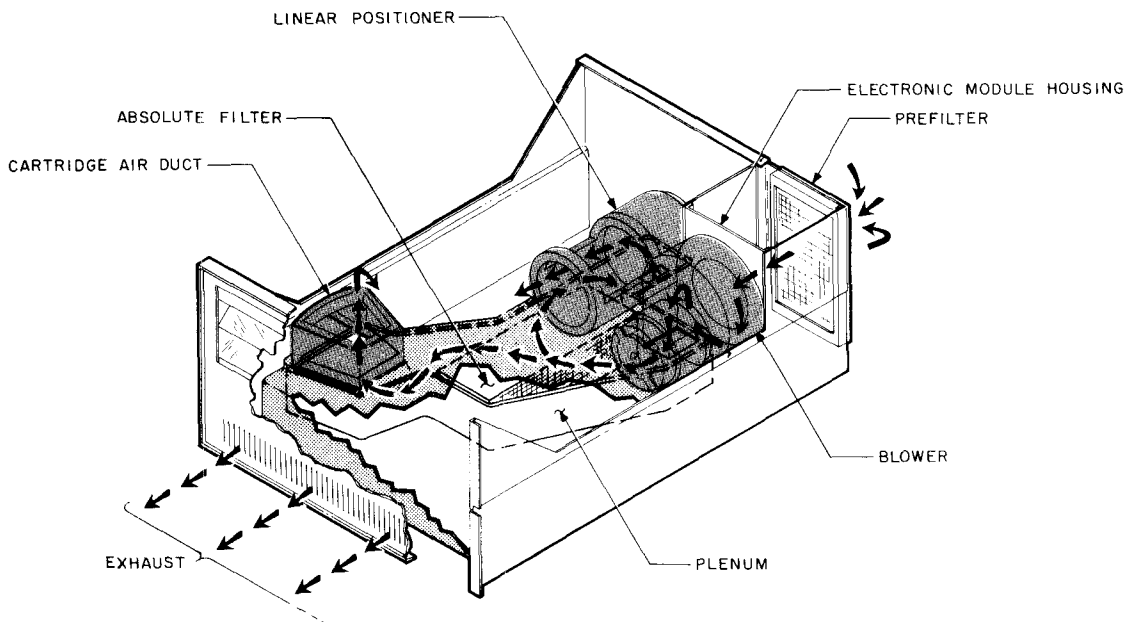

CP-0272

Figure 1-6 Air System

1.4.7 Power Supply

The power supply (Figure 1-1), located in the left rear portion of the disk drive, furnishes all the dc voltages for the drive. The power supply can operate with a 115 or 230V, 50 or 60 Hz line voltage input (Paragraph 4.3).

CHAPTER 2

INSTALLATION

2.1 UNPACKING AND INSPECTION

The RK05 Disk Drive can be shipped in a rack as an integral part of a system or in a separate container. If the drive is shipped in a rack, position the rack in the final installation location and unpack it as follows:

1. Remove the shipping brackets from the drive by removing the snap-on bezel beneath the lowest drive.
2. Remove the screws attaching the shipping bracket and latch molding to both sides of the drive.

CAUTION

Do not use the drive front door handle to pull the drive out from the rack.

3. Slide the drive out about 3 in. from the rack and pull the shipping brackets out from the sides of the drive. Attach the latch molding back onto the drive with the shipping bracket screws.
4. Slide the lowest drive out far enough to gain access to the shipping brackets on the drive directly above it and remove the screws from these two shipping brackets.
5. Repeat Steps 3 and 4 for each drive in the rack.
6. Remove the drive bottom covers and remove the three rubber shock-mount cushions which isolate the baseplate from the chassis.
7. Remove the top cover and the shipping bracket from the linear positioner.
8. Retain all packing material for possible return shipment and inspect the drive for damage. Report any damage to the carrier.

If the drive is shipped in a separate container, use care while unpacking it. Do not drop or subject the drive to unreasonable impact. Unpack the drive according to the packaging instructions shipped with each drive.

2.2 MECHANICAL INSTALLATION AND CHECKOUT

If the RK05 Disk Drive is to be installed in an existing rack, first install the chassis slides in the rack as illustrated in Figure 2-1, then mount the disk drive on the chassis slides as follows:

1. If the drive is to be mounted in a rack without sufficient weight to prevent tipping when the drive is fully extended, install cabinet stabilizers before mounting the drive.
2. Pull the chassis slides out until they lock in the extended position.
3. Slide the drive onto the chassis slides until it locks.
4. Remove the drive bottom covers and remove the three rubber cushions that isolate the baseplate from the chassis.

(continued on next page)

5. Remove the drive top cover and remove the shipping bracket from the linear positioner.
6. Inspect P2 and the spindle pulley to ensure that the drive is configured properly for the input power to be used (Paragraph 1.3).
7. Plug the BC11A interface cable into card position 7 or 8 of the electronic module. Ensure that an M930 terminator card (Dwg. No. RK05-0-2) is in the unused interface card position.
8. Fold the interface cable and route it through the slot just below the prefilter at the rear of the drive cabinet.
9. While holding the interface cable in position, replace the bottom cover.
10. Plug the power cord into the ac line receptacle.
11. Press the ON/OFF switch ON and ensure that power is properly applied to the drive.
12. Install a test cartridge on the spindle (Paragraph 2.3.1) and run the appropriate diagnostic tests to ensure proper electrical and mechanical drive operation.

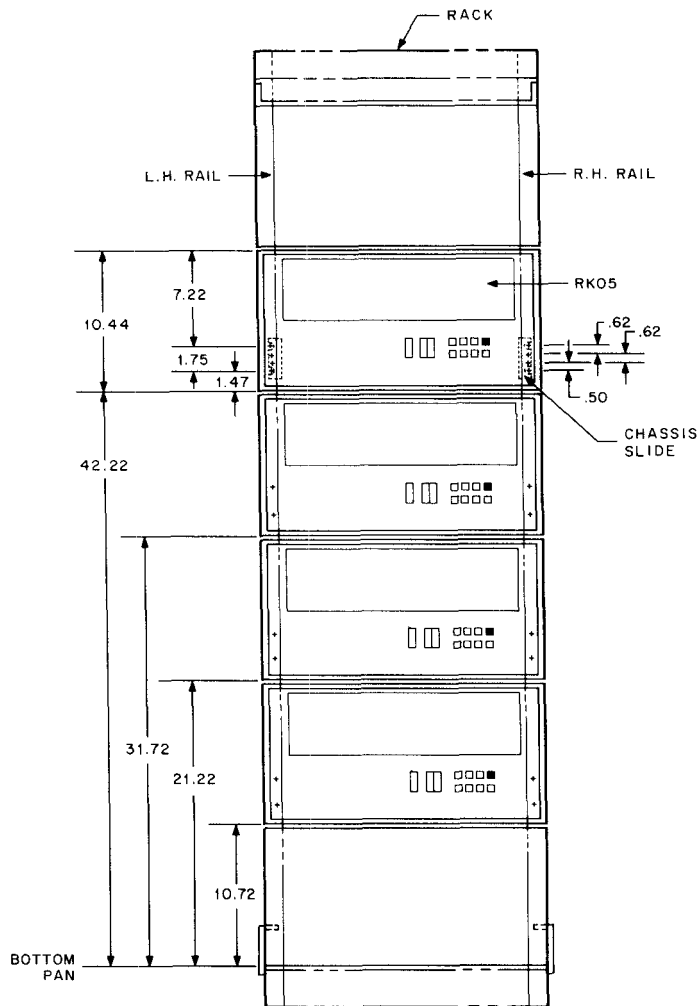

CP-0273

Figure 2-1 Chassis Slide Mounting

2.3 OPERATION

To obtain maximum performance and reliability from the RK05 Disk Drive, observe the following precautions and practices:

1. Do not expose the cartridge to excessive heat or dirt. Because the cartridge hub is slightly magnetic, do not expose it to metal chips, etc. To ensure correct seating of the hub on the spindle, periodically inspect and clean the cartridge hub.
2. Keep the drive front door closed to exclude unnecessary entry of atmospheric dust.
3. A sustained tinging or scratching sound may be caused by head-to-disk contact. If this occurs, immediately shut down the drive to avoid damage to the read/write heads. Examine the heads for oxide build-up and clean or replace them if necessary. Do not use the cartridge without first checking it for surface damage.
4. Cartridges can be stored flat or on edge. Several can be stacked on top of one another; however, avoid heavy top loading.
5. The disk cartridge is usually provided with a molded frame (on the front edge) that is designed to hold labels without the use of adhesives. It is better to replace a label than to alter one.

2.3.1 Disk Cartridge Installation and Removal

1. Place the front panel RUN/LOAD switch in the LOAD position and observe that the LOAD indicator lights.
2. Open the drive front door.

NOTE

As the door is opened, the cartridge receiver moves up into a slanted position for ease of cartridge insertion.

3. Fully insert a clean operable disk cartridge into the cartridge receiver.

CAUTION

Do not twist or force the cartridge into the receiver.

4. Close the drive front door and place the RUN/LOAD switch in the RUN position.
5. Allow about 8 sec for the drive to accelerate, then observe that the RDY indicator lights. The drive is now ready to perform seek, read, or write operations.
6. Remove the disk cartridge in the same way that it was installed. If another disk cartridge is not to be installed, close the drive front door to prevent entry of dust.

2.3.2 Normal Operating Procedures

To prevent excessive interface bus loading, all drives in a multi-drive system must have operating power applied even when the drive is not in use. In addition, unused drives should be left write-enabled, and with the RUN/LOAD switch in the LOAD position. If the drive power is controlled by a processor keyswitch, all drive ON/OFF switches may be left ON; however, set all RUN/LOAD switches to LOAD before removing system power. To prepare a system for normal operation, proceed as follows:

1. Set the ON/OFF switch on all drives to ON.
2. Set the RUN/LOAD switch on all drives to LOAD.

(continued on next page)

3. If applicable, turn the processor keyswitch on.

CAUTION

If the LOAD indicator is not lit or if power is not applied, the drive front door is locked. If this is the case, DO NOT ATTEMPT TO FORCE THE DRIVE FRONT DOOR OPEN.

4. Set the address select switch of the drive to be used to the desired address (Paragraph 4.2.4) and install the required disk cartridge (Paragraph 2.3.1).
5. Using the WT PROT switch, set the drive to write-enable (WT PROT indicator off).
6. Place the drive in the RUN mode and wait for the RDY indicator to light. If RDY does not light or the FAULT indicator lights, there is an abnormal condition in the drive. (Refer to Paragraph 5.5 for troubleshooting procedures.)

CHAPTER 3

INTERFACE

3.1 GENERAL

Interface connection of the RK05 Disk Drive is made with a BC11A Cable to card position 7 or 8 of the electronic module. These card positions are parallel-wired, so that up to four drives may be serially connected in a multi-drive, "party-line" configuration. That is, card position 7 or 8 of the first drive is connected to card position 7 or 8 of the following drive, etc. If there is only one drive in the system, an M930 Terminator Card must be installed in the unused interface card position. If there is more than one drive in the system, only the last drive of the "party-line" must have the M930 Terminator Card in the unused interface card position. The interface signal levels are determined by the M930 Terminator Card. An assertion or logic 1 is approximately +0.5 Vdc, while a negation or logic 0 is approximately +3.5 Vdc. Figure 3-1 illustrates, and the following paragraphs describe the function of each interface line.

3.2 INPUT INTERFACE LINES

3.2.1 Select (4 Lines)

These four lines and a four-position address select switch on the M7700 card, determine the drive address assignment and selection. In a particular drive, only one of these lines is internally connected (via the address select switch) to the drive control logic. In order to select a drive, the controller places a +0.5 Vdc level (logical 1) on the desired SELECT line. This line remains at logical 1 during the entire read, write, or control operation. When the drive is not selected, the SELECT line is at +3.5 Vdc (logical 0).

3.2.2 Cylinder Address (8 Lines)

These eight lines determine the cylinder position of the read/write heads. In order to move the heads to a desired cylinder, the controller places a corresponding 8-bit binary code on the lines (valid codes = 0 through 202). These lines are then gated by the STROBE signal, to position the heads at the selected cylinder. The binary code remains on the lines until either the ADDRESS ACCEPTED or ADDRESS INVALID signal is returned from the drive (Paragraph 3.3.3).

3.2.3 Strobe

This line transmits a signal that gates the CYLINDER ADDRESS or RESTORE lines. The controller places a 0.5 Vdc level (logical 1) on the STROBE line, only after the CYLINDER ADDRESS or RESTORE signals (Paragraph 3.2.8) are fully settled on their respective lines. Strobe remains at logical 1 until either the ADDRESS ACCEPTED or ADDRESS INVALID signal is returned from the drive.

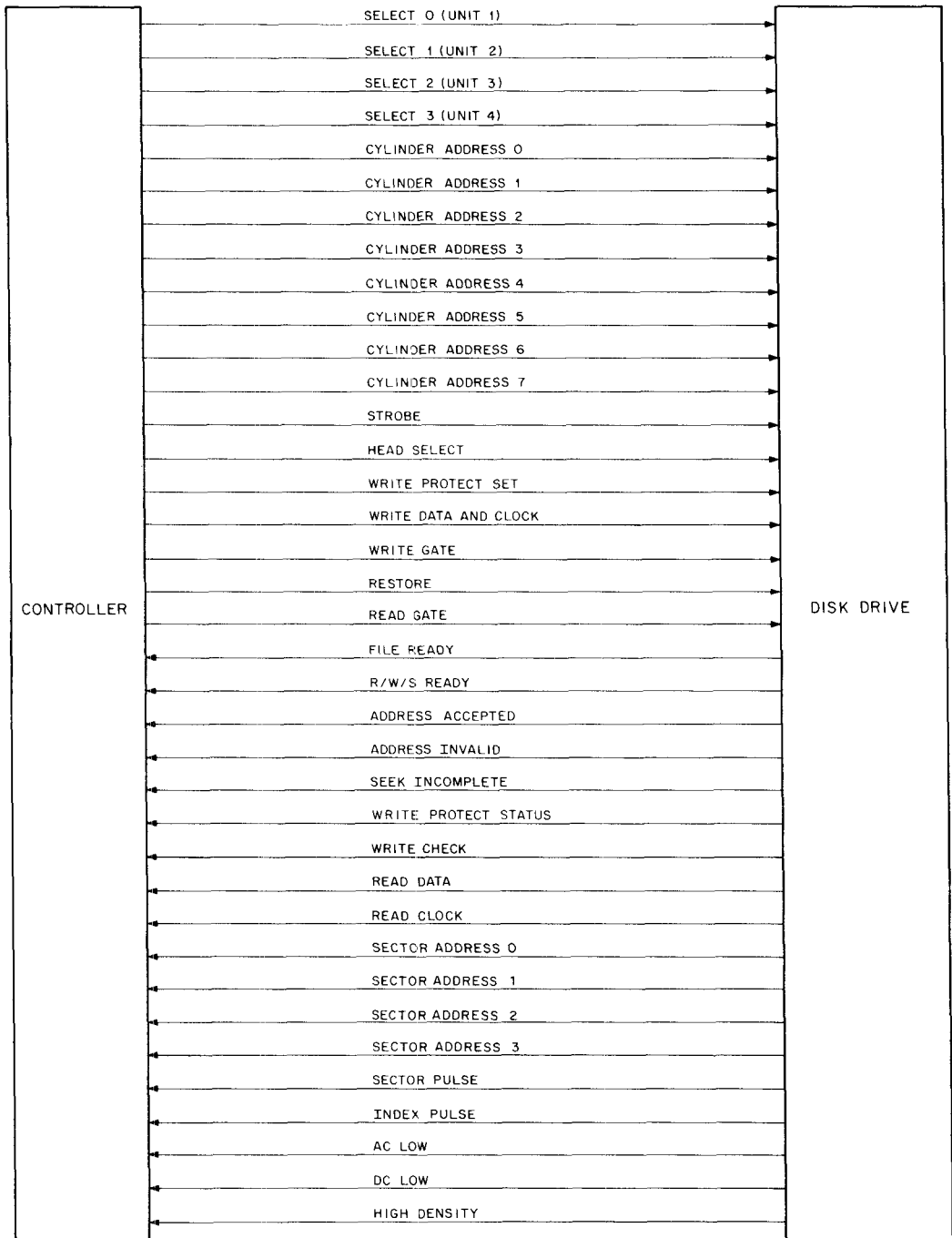

CP-0238

Figure 3-1 Controller-to-Disk Drive Interface Lines

3.2.4 Head Select

This line transmits a signal that determines which of the two read/write heads is to be selected. The controller places a +0.5 Vdc level (logical 1) on this line to select the upper head, and a +3.5 Vdc level (logical 0) to select the lower head. Either signal remains on the line throughout the entire read or write operation.

3.2.5 Write Protect Set

This line transmits a signal that disables the disk drive write amplifiers to prevent a write operation. The controller places a +0.5 Vdc level (logical 1) on this line to set the Write Protect flip-flop and inhibit the write capability of the drive. The Write Protect flip-flop is also set if the WT PROT indicator is off and the operator presses the WT PROT switch (Paragraph 1.4.1).

The Write Protect flip-flop is reset if the WT PROT indicator is on and the operator presses the WT PROT switch; or the operator sets the RUN/LOAD switch to LOAD and then back to RUN. When power is applied to the drive, the internal power start sequence also resets the Write Protect flip-flop. Thus, in the event of a power failure, with subsequent restoration, the drive will be write-enabled, regardless of the previous conditions.

3.2.6 Write Data and Clock

This line transmits multiplexed data and clock pulses to the disk drive.

3.2.7 Write Gate

This line transmits a signal to simultaneously turn on both the write and erase current in the selected write head. The controller places a +0.5 Vdc level (logical 1) on this line 1 μ s prior to transmitting the write data. This line remains at logical 1 throughout the data transmission time.

3.2.8 Restore (RTZ)

This line transmits a signal to position the read/write heads at cylinder zero. The controller places a +0.5 Vdc level (logical 1) on this line prior to issuing the STROBE signal. About 2 μ s after STROBE is issued, the drive returns an ADDRESS ACCEPTED signal, clears the Address Register, and moves the heads to track zero. The RESTORE line remains at logical 1 until ADDRESS ACCEPTED is received by the controller.

3.2.9 Read Gate

This line transmits a signal that allows data to be read from the disk drive. The controller places a +0.5 Vdc level (logical 1) on this line to enable the READ CLOCK and READ DATA output lines. This line remains at logical 1 throughout the entire read operation.

3.3 OUTPUT INTERFACE LINES

3.3.1 File Ready

This line transmits a +0.5 Vdc level (logical 1) to indicate the following conditions:

- a. Drive operating power is correct.
- b. A disk cartridge is properly loaded.
- c. The drive front door is closed.
- d. RUN/LOAD switch is in the RUN position.
- e. Spindle is rotating at the correct speed.
- f. Read/write heads are loaded.
- g. WRITE CHECK is false.

3.3.2 R/W/S Ready (Read, Write, or Seek Ready)

This line transmits a +0.5 Vdc level (logical 1) to indicate that the drive is in the File Ready condition (Paragraph 3.3.1) and is not performing a seek operation.

3.3.3 Address Accepted

This line transmits a 5- μ s pulse (logical 1) to indicate that the drive has accepted a Seek command with a valid address, and command execution has begun. This line goes to logical 1 about 2 μ s after receipt of the STROBE signal, even if there is no change from the present address.

3.3.4 Address Invalid

This line transmits a 5- μ s pulse (logical 1) to indicate that the drive has received a nonexecutable Seek command with a cylinder address greater than 202. In this case, the Seek command is suppressed in the drive, and the heads are not moved. Timing is the same as for ADDRESS ACCEPTED.

3.3.5 Seek Incomplete

This line transmits a +0.5 Vdc level (logical 1) to indicate that some malfunction in the drive did not allow the seek operation to be completed. This line remains low, until a Restore command is received, or the operator sets the RUN/LOAD switch to LOAD and then back to RUN.

3.3.6 Write Protect Status

This line transmits a +0.5 Vdc level (logical 1) to indicate that the drive is write-protected (write capability inhibited). When this line is at logical 1, the WT PROT indicator on the drive control panel lights (Paragraphs 1.4.1 and 3.2.5).

3.3.7 Write Check

This line transmits a +0.5 Vdc level (logical 1) to indicate the following conditions:

- a. erase or write current without a WRITE GATE or,
- b. head position transducer lamp inoperative

When WRITE CHECK is a logical 1, all external commands to the drive are suppressed and the FAULT indicator on the drive control panel lights. If the fault condition is temporary, the operator may press the WT PROT switch to turn off the FAULT indicator. This action causes the FAULT indicator to go out; however, the WT PROT indicator lights. The WT PROT switch must be pressed a second time to turn off the WT PROT indicator (Paragraphs 1.4.1 and 3.2.5).

3.3.8 Read Data

This line transmits read data only (100-ns pulses).

3.3.9 Read Clock

This line transmits read clock pulses only (100-ns pulses).

3.3.10 Sector Address (4 Lines)

These four lines indicate which sector is passing under the read/write heads. The sector address is a 4-bit binary code derived from the sector address counter.

3.3.11 Sector Pulse

This line transmits a 2- μ s pulse (logical 1) each time a sector slot passes the sector transducer. The index slot (unique slot) is suppressed in this line and is transmitted on a separate INDEX PULSE line.

3.3.12 Index Pulse

This line transmits a single 2- μ s pulse (logical 1) for each revolution of the disk. The INDEX PULSE occurs 600 μ s after the sector 11 pulse and is generated each time the index slot (unique slot) is detected by the sector transducer.

3.3.13 AC Low

This line transmits a +0.5 Vdc level (logical 1) when there is a loss (for more than 90 ms) of the 30 Vac within the drive. When AC LOW occurs, the drive finishes recording the current sector, then initiates a normal head-retract and unload cycle. If a total power loss occurs before the heads are completely retracted, the safety relay is de-energized, retracting the heads under battery power (emergency retract), and maintaining the AC LOW signal.

3.3.14 DC Low

This line transmits a +0.5 Vdc level (logical 1) when the ± 15 Vdc within the drive drops to 12 Vdc or below. When DC LOW is generated, the safety relay is de-energized, retracting the heads under battery power (emergency retract), and maintaining the DC LOW signal.

3.3.15 High Density

This line transmits a +0.5 Vdc level (indicating high density only) whenever the drive is selected.

CHAPTER 4

THEORY OF OPERATION

4.1 FUNCTIONAL DESCRIPTION

Figure 4-1 illustrates the major areas and associated signals of the RK05 Disk Drive. Together, they rotate the recording disk, align the heads at a specified cylinder, and perform the read and write functions.

Paragraphs 4.1.1 through 4.1.5 describe the major operations of the disk drive; Paragraphs 4.2.1 through 4.2.10 describe the detailed logical sequence of each major operation.

4.1.1 Start

During the start cycle, the control and interlock logic controls the spindle motor operation. In order to energize the spindle motor, the RUN/LOAD switch must be in the RUN position and the following interlock conditions present:

- a. operating power applied
- b. the drive front door closed
- c. a disk cartridge properly installed
- d. the read/write heads fully retracted (unloaded)

If the preceding interlock conditions are safe, the spindle motor is energized. After an 8-sec delay to allow the spindle to accelerate to operating speed, the control and interlock logic generates an internal LOAD HEADS signal which loads the read/write heads and positions them at cylinder zero (Paragraph 4.2.5.1). When the heads are loaded and positioned at cylinder zero, the RDY and ON CYL indicators light, and the READY interface line goes low.

Figure 4-2 illustrates the logical sequence during the start cycle. Refer to Paragraph 4.2.2 for a detailed logic description of the preceding events.

4.1.2 Stop

The three ways in which the disk drive can enter a stop cycle are:

- a. placing the RUN/LOAD switch to LOAD
- b. a loss of spindle speed
- c. a loss of operating voltage

If any of the preceding conditions occur, the control and interlock logic removes the internal LOAD HEADS signal and brings the READY interface line high. When LOAD HEADS is removed, the position control logic retracts the read/write heads. After the heads are fully retracted, the spindle motor is de-energized and the spindle coasts to a stop (about 30 sec). When the spindle has stopped rotating, the LOAD indicator lights, and the drive front door is unlocked.

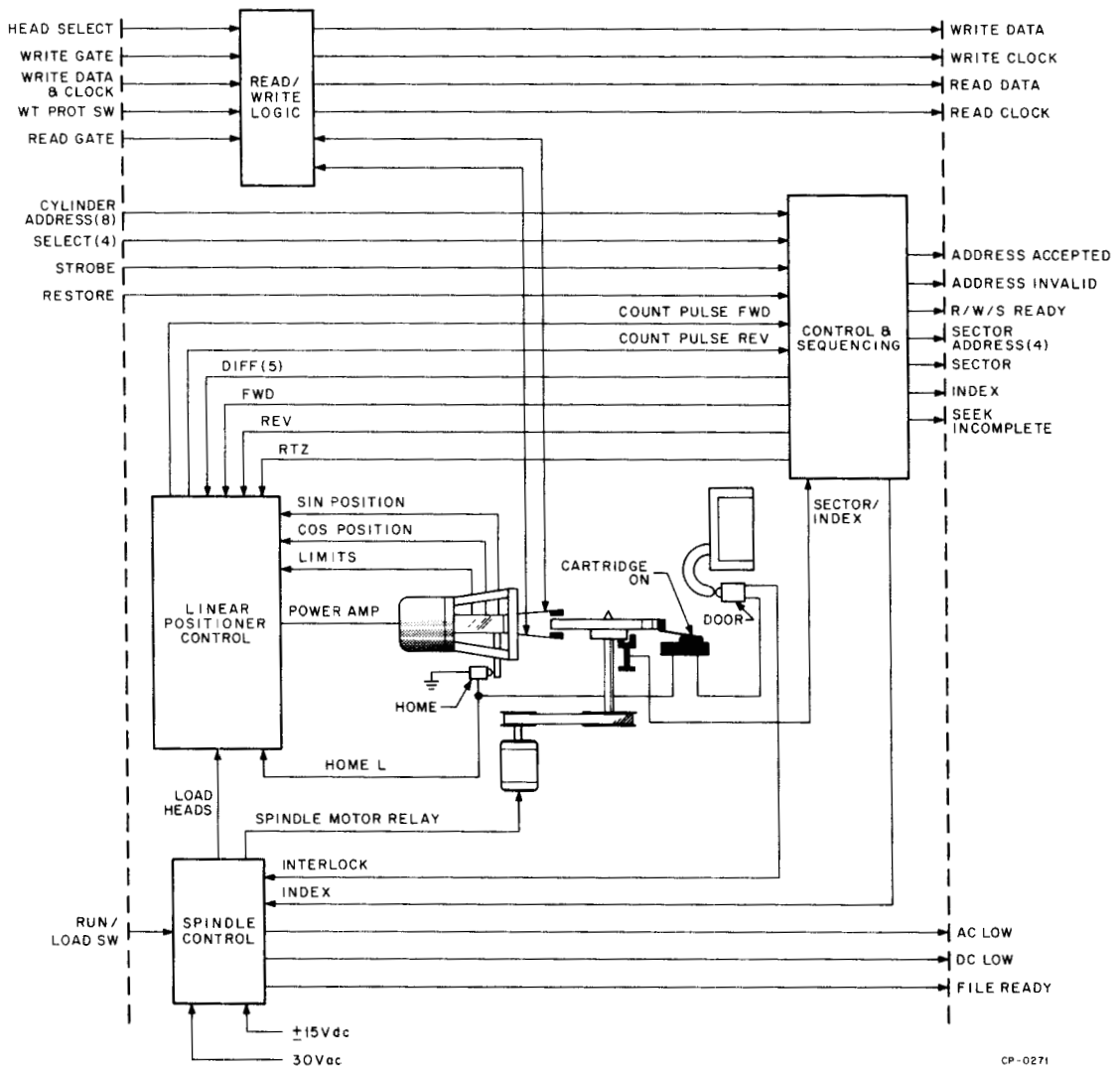

Figure 4-1 Functional Block Diagram

Figure 4-3 illustrates the logical sequence during the stop cycle. Refer to Paragraph 4.2.3 for a detailed logic description of the preceding events.

4.1.3 Track Addressing and Head Positioning

In order to move the read/write heads from a current location to a new location above the disk (a seek operation), a selected drive must first receive an 8-bit binary cylinder address from the controller. If the new address exceeds cylinder 202, the ADDRESS INVALID interface signal is generated and head motion is suppressed. If the new address does not exceed cylinder 202, the ADDRESS ACCEPTED interface signal is generated and the new address is compared to the current address. The comparison result (difference) is fed to a position servo system to move the heads.

As the heads pass each cylinder, output pulses from the optical positioner transducer trigger a difference register to control the velocity of head motion (Paragraph 4.2.6). As the heads approach the destination cylinder, the

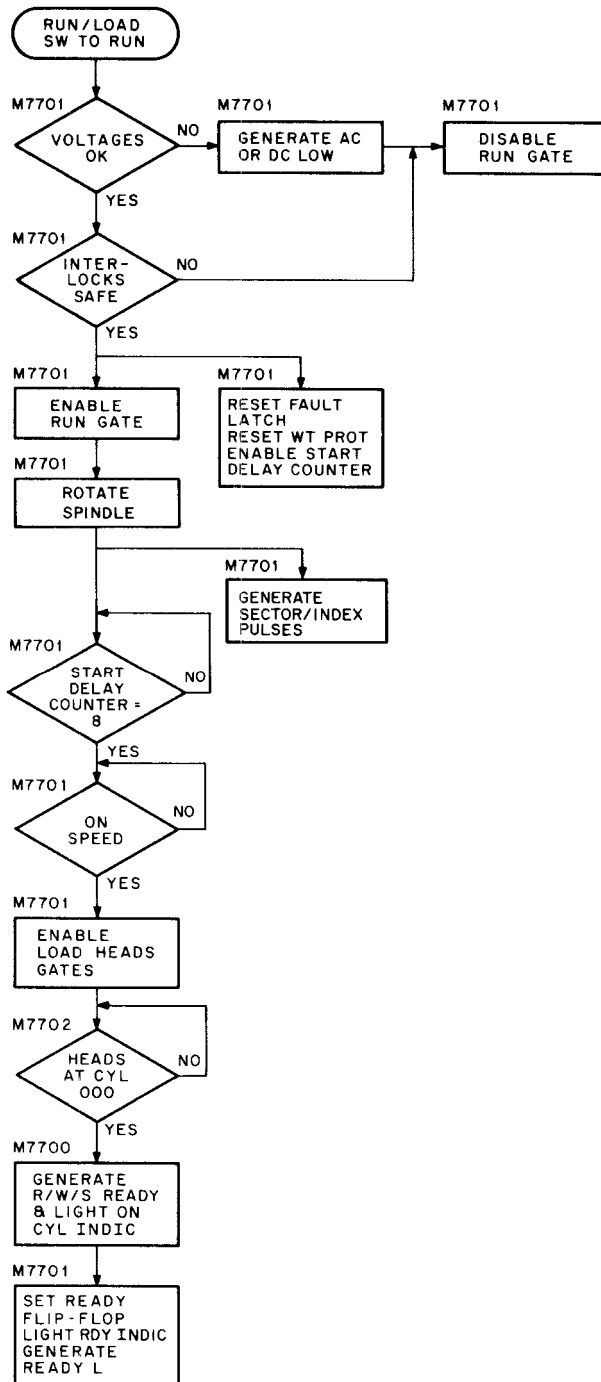

CP-0241

Figure 4-2 Start Flow Chart

head positioner decelerates, eventually stopping the heads at the designated cylinder. After a small delay to allow the heads to settle at the new location, the ON CYL indicator on the control panel lights and the R/W/S READY interface line goes low.

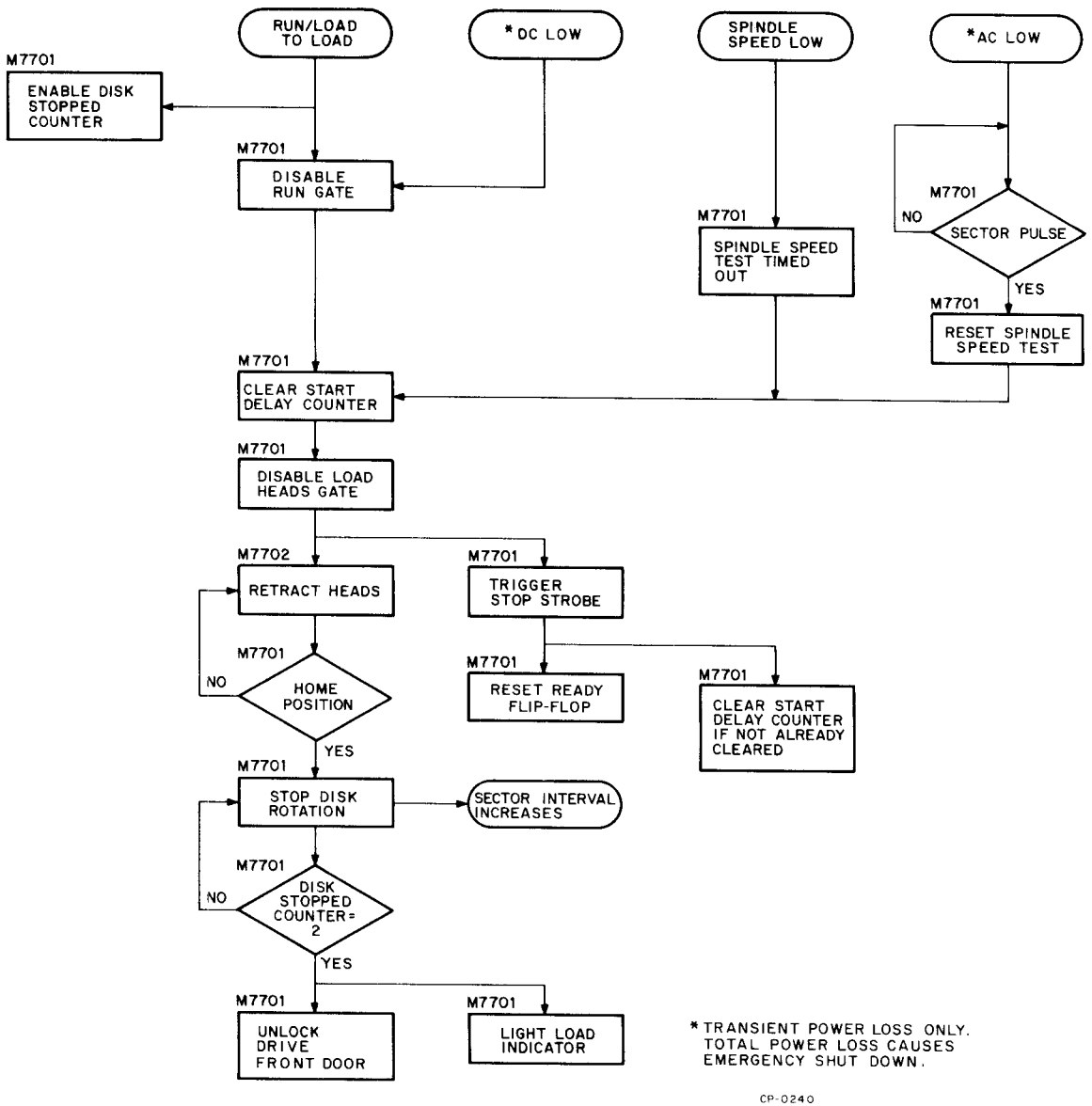

Figure 4-3 Stop Flow Chart

If, at any time during the seek operation, a return-to-zero (Restore) command is received or the heads reach the inner limit of the disk, the seek operation is immediately terminated and the heads are retracted to cylinder zero.

Figures 4-4 and 4-5 illustrate the logical sequence during a seek or return-to-zero operation. Refer to Paragraph 4.2.5 for a detailed logic description of the preceding events.

4.1.4 Read/Write Heads

There are two ramp-loaded read/write heads in the RK05 Disk Drive. One head functions on the top and the other on the bottom surface of the recording disk. The heads are mounted on suspension arms that rest, when the heads are unloaded, on a plastic cam block of the duckbill (Figure 4-6). Flat cantilever springs connect the

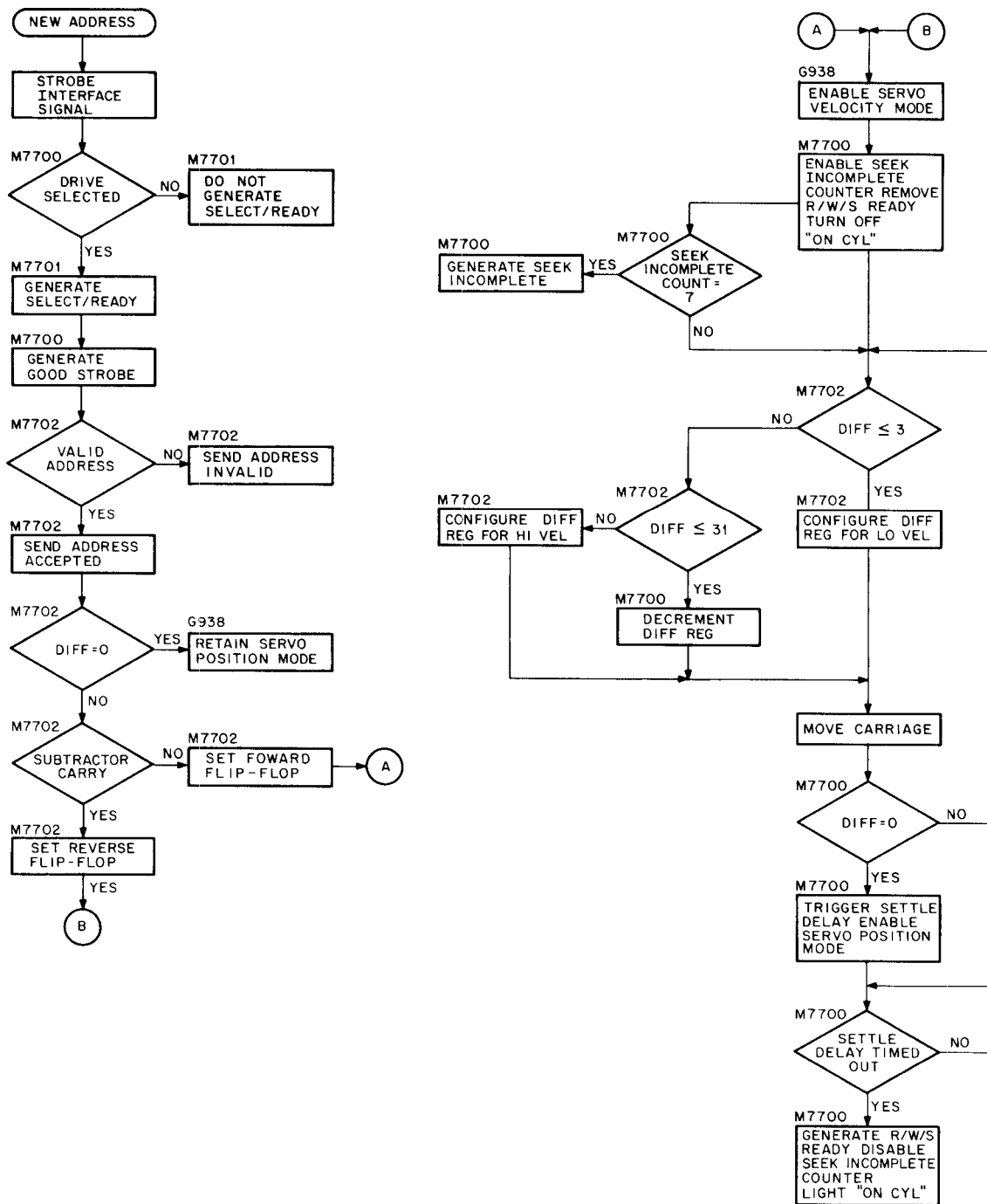

CP-0276

Figure 4-4 Seek Flow Chart

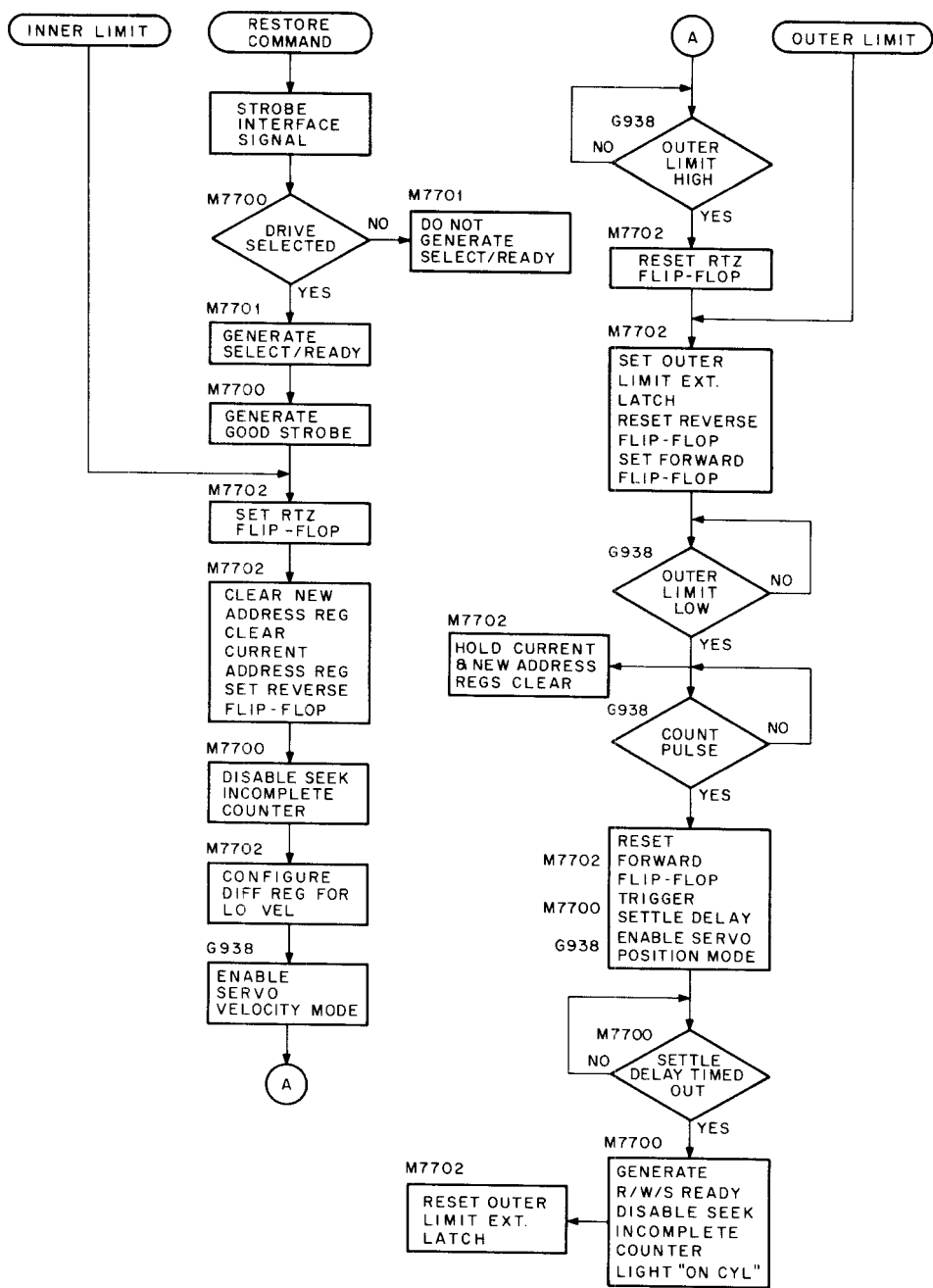

CP-0275

Figure 4-5 Return-to-Zero (Restore) Flow Chart

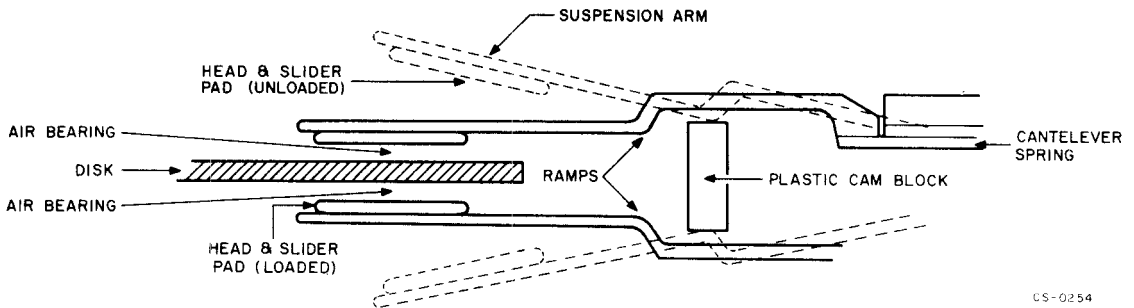

Figure 4-6 Head Loading

suspension arms to the head-support tail pieces. When the drive is placed in the RUN mode, the positioner moves the heads forward toward cylinder zero. When the entire head slider pad has passed the edge of the disk, a ramp on the suspension arm slides down the edge of the plastic cam block, thereby moving (loading) the heads close to the disk surface. When loaded, the heads “fly” 80 to 100 microinches from the disk surface. A film of air (air bearing) between the disk and the head acts as a force away from the disk, while the cantilever spring is a counterbalancing force towards the disk. Thus, as long as the disk rotation remains constant, the heads remain at a relatively constant distance away from the disk surface.

Each head is a 4-terminal magnetic device containing two coils. A center-tapped coil performs the read or write function, while the other series-connected coil performs the erase function. The head (Figure 4-7) is designed so that the erase coil is electrically connected to the center tap of the read/write coil and is energized (Figure 4-8) whenever a write operation occurs. This head configuration, called “straddle erase” erases any residue from a previous recording between the .006-in. wide tracks and thus eliminates track “crosstalk” or interference from a previous recording. During a write operation, current through the write coil automatically overwrites old data.

4.1.5 Recording Technique

The recording device (read/write head) is a coil-wound ferrite core with an air gap. As current flows through the coil, the induced flux magnetizes the surface of the disk passing under the gap. During a write operation, when the current direction in the coil is reversed, a flux reversal is recorded on the disk. During a read operation, the previously recorded flux pattern on the disk induces current in the head. Any change in flux on the recording surface produces a pulse.

The RK05 Disk Drive uses a double-frequency, nonreturn-to-zero (NRZ) method of magnetic recording. In this method, flux reversals (clock pulses) are recorded on the magnetic disk at regularly spaced intervals (Figure 4-9). The time period between these clock pulses is a bit cell, and data storage occurs within these cells. A flux reversal during a bit cell represents a logical 1, while the absence of a flux reversal during a bit cell represents a logical 0.

4.2 LOGICAL DESCRIPTION

4.2.1 Power On/Off Sequence

Placing the ON/OFF switch on the front control panel in the ON position applies ac power to J4 pin 2 (H743). This action lights the PWR indicator, turns on the blower, energizes the various voltage regulators, and activates the elapsed time indicator.

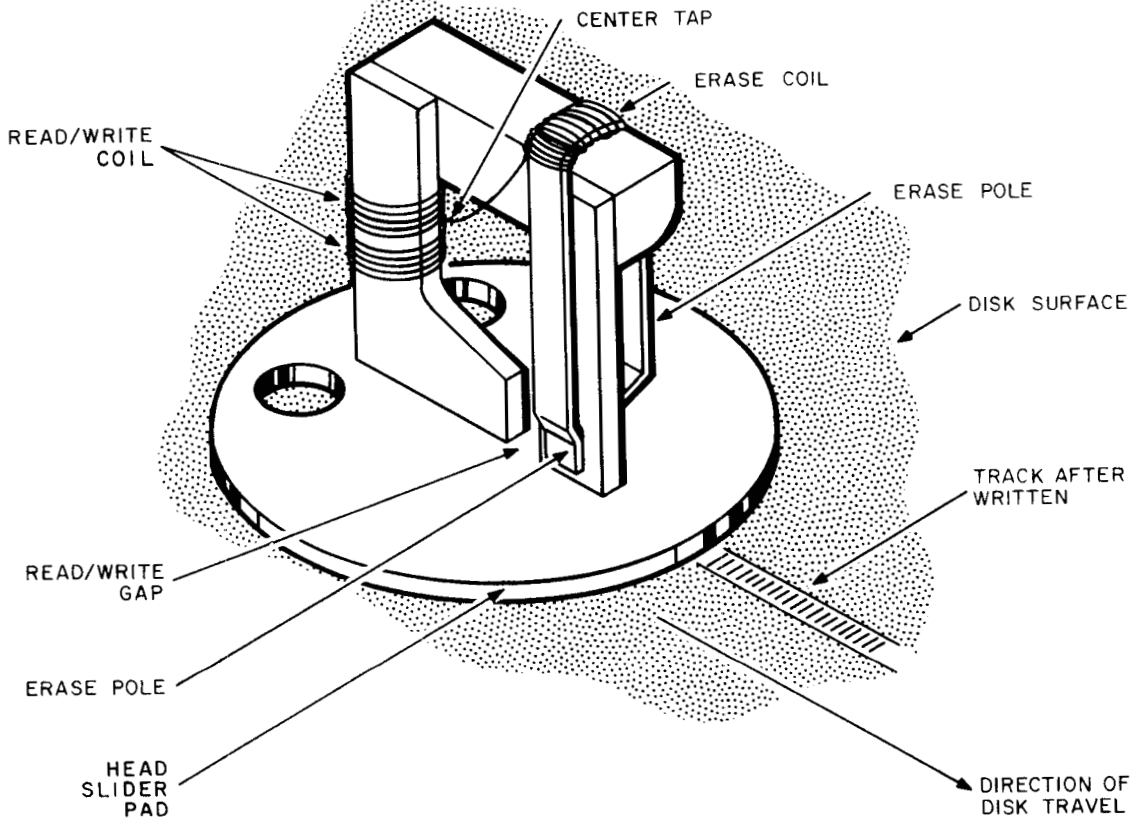

CP-0257

Figure 4-7 Read/Write Head

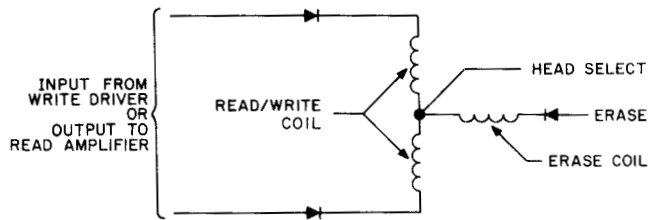

CP-0258

Figure 4-8 Simplified Read/Write Head Circuit

Placing the ON/OFF switch in the OFF position turns off the PWR indicator and removes all ac power from the drive. If ac power is removed when the read/write heads are not in the "home" position, the "home" micro-switch applies battery power to the linear motor, retracting the heads to the "home" position.

4.2.2 Start

Figure 4-10 is a block diagram that illustrates the logical elements used in a start/stop cycle; however, the description in the text that follows, relates directly to Logic Diagram M7701.

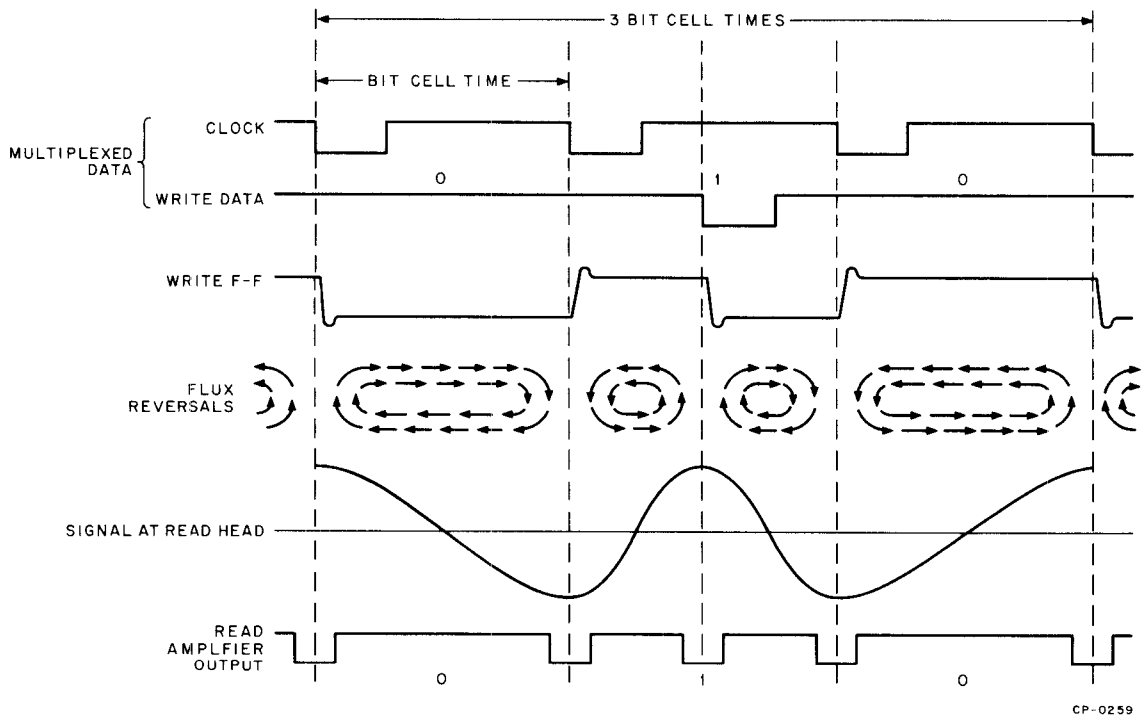

Figure 4-9 Double Frequency Pulse Relationship

Placing the RUN/LOAD switch on the front control panel in the RUN position sets the Run/Load latch (M7701) and enables pin 9 of the run gate. If a disk cartridge has been properly installed, the drive front door closed, and the read/write heads fully retracted; the INTERLOCK L signal is low, enabling pin 10 of the run gate. If the +15 and -15 Vdc are above 12 Vdc (Paragraph 4.2.3.4), the voltage test gate produces an output that enables pin 11 of the run gate.

When all three legs of the run gate are enabled, an output is produced that performs the following:

- a. sets the spindle motor latch
- b. enables the start-delay counter
- c. triggers the run-strobe one-shot, to reset the fault latch and Write Protect flip-flop

When the spindle motor latch sets, driver E5 conducts, energizing the spindle motor relay and initiating disk rotation. Simultaneously, the start-delay counter begins to count pulses (1 pulse per second) from the slow clock. When a count of 8 (8 sec) is reached, pin 12 of the counter goes low and is recirculated to prevent the counter from incrementing further. Pin 11 also goes high at this time, and is applied to the load-heads gate. If the spindle has accelerated to the correct operating speed (Paragraph 4.2.3.2), the second leg of the load-heads gate is enabled, thus producing the LOAD HEADS signal. The output from the load-heads gate also primes the data input of the Ready flip-flop.

When LOAD HEADS is produced, the read/write heads are moved to cylinder zero (Paragraph 4.2.5.1). Once the heads are positioned and settled at cylinder zero, the signal R/W/S READY is produced, which lights the ON CYL indicator (M7700). This signal also sets the Ready flip-flop, resulting in a READY interface signal, and lighting the RDY indicator on the control panel. The drive is now ready to perform a seek, read, or write operation.

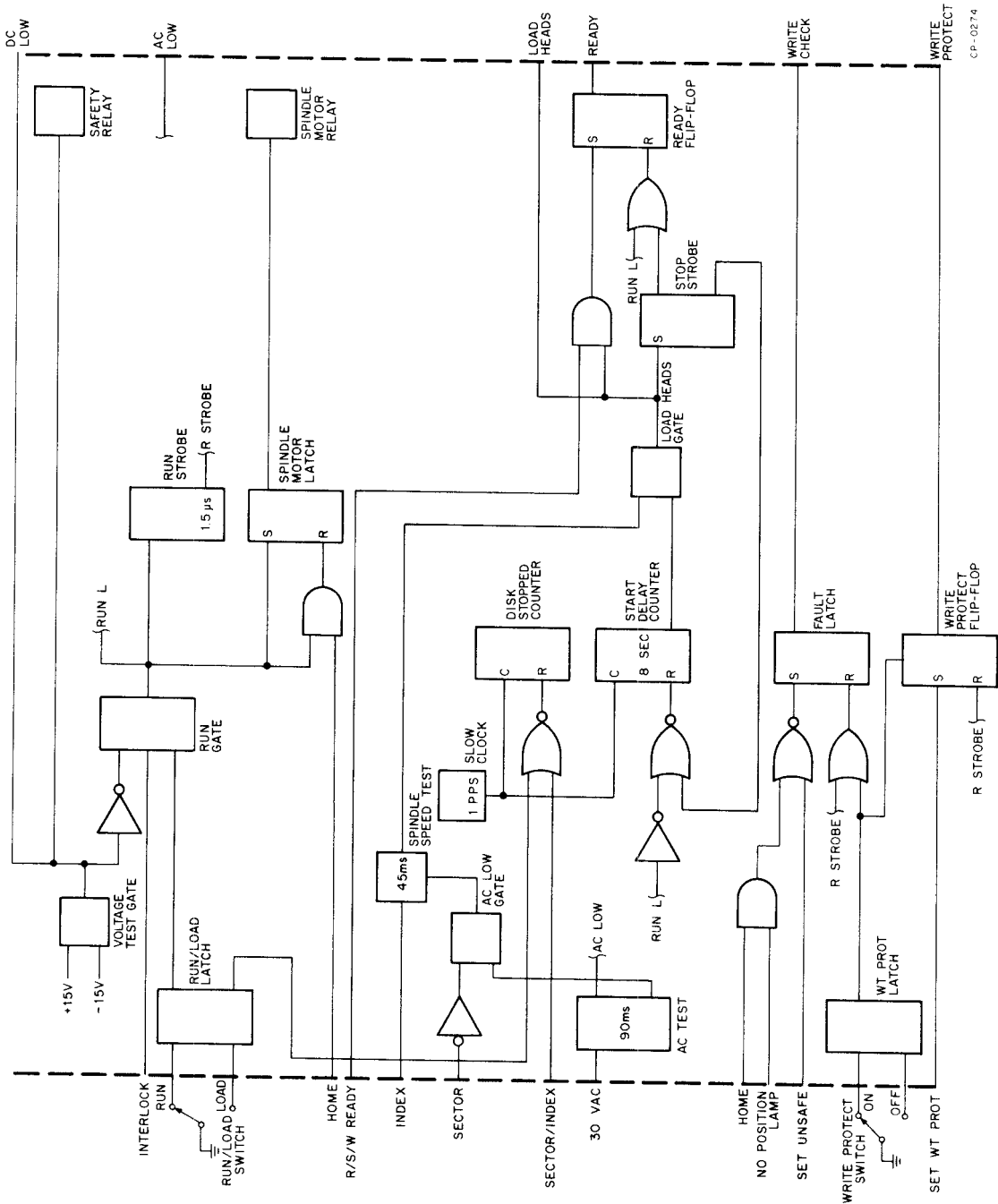

CP-0274

Figure 4-10 Control and Interlock Block Diagram

4.2.3 Stop

The following paragraphs describe the three ways that the disk drive can enter a stop cycle. Figure 4-10 is a block diagram that illustrates the logical elements used in a start/stop cycle; however, the description in the text that follows, relates directly to Logic Diagram M7701.

4.2.3.1 Normal Stop – Placing the RUN/LOAD switch on the front control panel in the LOAD position enables the disk-stopped counter and disables pin 9 of the run gate (M7701), causing RUN L to come high. The disk-stopped counter begins to increment; however it is reset by every SECTOR/INDEX pulse before reaching a count of 2. This practice keeps the door unlocking solenoid from being energized, and prevents the operator from opening the drive front door before the disk has come to a complete halt. RUN L high performs the following:

- a. Clears the start-delay counter, disabling pin 5 of the load-heads gate, thus removing the LOAD HEADS signal. Once cleared, the start-delay counter must again increment to eight before the LOAD HEADS signal can be generated. This practice allows the heads to fully retract (unload) before they can be loaded again.
- b. Triggers the stop-strobe one-shot, to reset the Ready flip-flop.

When the LOAD HEADS signal is removed, the position control logic retracts the read/write heads (Paragraph 4.2.5.3). When the heads are fully retracted (unloaded) the “home” microswitch closes, generating the HOME L signal. HOME L causes the spindle motor latch to reset, de-energizing the spindle motor, and allowing the spindle to coast to a stop. As the spindle decelerates, SECTOR/INDEX pulses occur at a slower rate. Approximately 30 sec after the disk-stopped counter is enabled, the disk stops rotating, SECTOR/INDEX pulses cease, and the disk-stopped counter is incremented by two pulses from the slow clock. With the counter at 2 (2 sec from the receipt of the last SECTOR/INDEX pulse), the high output from pin 12 is recirculated to prevent the counter from incrementing further, while the high output from pin 9 energizes the door unlocking solenoid, and lights the LOAD indicator on the control panel. The drive front door can now be opened and the cartridge removed.

4.2.3.2 Low Speed Stop – When the disk is rotating at normal speed (1500 rpm), INDEX pulses are generated every 40 ms and trigger the 45-ms spindle-speed test one-shot (M7701). The one-shot output is applied to an associated flip-flop. As long as the spindle rotation remains above an unsafe speed, successive INDEX pulses keep the flip-flop set, thus maintaining the LOAD HEADS signal. If the spindle speed drops below approximately 1200 rpm, the INDEX pulse rate increases beyond 45 ms. If this occurs, the spindle-speed test one-shot times out, and resets the associated flip-flop. With the flip-flop reset, the load-heads gate is disabled and the LOAD HEADS signal is removed, thus causing the position control logic to retract the read/write heads (Paragraph 4.2.5.3). When LOAD HEADS is removed, stop-strobe triggers, resetting the Ready flip-flop and clearing the start-delay counter. Once cleared the start-delay counter must again increment to eight before the LOAD HEADS signal can be generated. This practice allows the heads to fully retract (unload) before they can be loaded again.

The remainder of the low-speed stop cycle is the same as a normal stop (Paragraph 4.2.3.1).

4.2.3.3 AC Low Stop – During normal operation, the ac-test one-shot (M7701) is repeatedly triggered set by the presence of 30 Vac. If this voltage is removed for more than 90 ms (approximately five ac cycles), the ac-test one-shot times out. With the one-shot reset, the AC LOW interface signal is generated and pin 9 of the ac-low gate is enabled. Following the AC LOW signal, the drive continues to operate until the next SECTOR pulse occurs. At this time, pin 10 of the ac-low gate is enabled and an output is produced to reset the spindle-speed test one-shot. This practice allows a data transfer in progress to continue until the end of the sector before the interface signals are removed.

The remainder of the ac-low-stop cycle is the same as a low-speed stop (Paragraph 4.2.3.2). However, if a total power loss occurs before the heads are completely retracted, the safety relay (5409474) closes, retracting the heads under battery power (emergency retract), and maintaining the AC LOW interface signal.

4.2.3.4 DC Low Stop – If the +15 or - 15 Vdc drops below 12 Vdc, the voltage-test gate (M7701) is disabled. The voltage-test gate output immediately disables the run gate, de-energizes the safety relay to retract the heads under battery power, and generates the DC LOW interface signal.

4.2.4 Disk Drive Addressing

For greater flexibility in a multi-drive system, the disk drive address can be changed by changing the position of the address select switch on the M7700 card. Placing this switch in any one of the four positions, connects the input of gate E22 to the associated SELECT interface line. When the appropriate SELECT signal goes low, gate E22 is enabled and SELECT H comes high. If the drive is ready and there are no fault conditions, SELECT H is ANDed with the set output from the Ready flip-flop (M7701) and the reset output from the Fault latch to produce the signal SELECT/READY L. This signal allows the drive to perform the various control and read/write operations.

4.2.5 Seek

4.2.5.1 Load Heads Seek – Placing the RUN/LOAD switch in the RUN position generates the LOAD HEADS L signal (Paragraph 4.2.2). Because the read/write heads are in the “home” position, OUTER LIMIT H is high (M7702). This signal is ANDed at gate E2 pins 4 and 5, with the inverted LOAD HEADS L signal, to set the Forward and reset the Reverse flip-flops. OUTER LIMIT H also sets the outer-limit-extender latch to hold the new and current address registers at 0.

The reset outputs from the new address register and the set outputs from the current address register are applied to the subtractor. Using the reset outputs of the new address register effectively complements the new address. Thus, a 1's complement addition operation takes place in the subtractor.

Because the current address register and the new address register have both been cleared, the result of the 1's complement addition performed in the subtractor produces a low output signal (no-carry condition) at E26 pin 14. The binary 0 from the subtractor is inverted by the E23, E28 exclusive-OR circuits, causing E14 (≤ 3) pin 6 to go low. This signal configures the difference register to a low-velocity binary output.

NOTE

Low velocity is when all stages of the difference register are set. High velocity is when all stages are cleared.

When the Forward flip-flop sets, FWD H and MOVE L are generated, and gate E13 pin 1 is enabled. FWD H is sent to the servo logic, placing it in velocity mode and initiating forward head motion (Paragraph 4.2.6.1).

As the heads begin to move at low velocity toward cylinder zero, count pulses are generated by the position transducer (Paragraph 4.2.6). When the heads pass the outer limit of the recording disk, OUTER LIMIT H goes low, producing a low output at gate E13 pin 8. As the heads approach cylinder zero, COUNT PULSE REV H (first count pulse after OUTER LIMIT H goes low) enables E13 pin 2, resetting the Forward flip-flop, removing FWD H and MOVE L, and placing the servo logic in the detent mode (Paragraph 4.2.6.3).

MOVE L high triggers the 5-ms E19 positioner-settler-delay one-shot (M7700). When E19 times out, the E13 flip-flop resets; disabling the seek-incomplete counter, lighting the ON CYL indicator, and causing the R/W/S READY interface signal to go low. R/W/S READY H also comes high at this time, clearing the outer-limit-extender latch.

4.2.5.2 Forward Seek – In order to move the read/write heads closer to the disk spindle (forward seek), the controller places an 8-bit binary address on the CYLINDER ADDRESS interface lines, transmits a STROBE pulse, and simultaneously addresses the disk drive (Paragraph 4.2.4). SELECT/READY L is ANDed with STROBE (M7700) to trigger the 150-ns E19 strobe generator one-shot. When E19 times out, E18 triggers, generating the GOOD STROBE L pulse which clocks the cylinder address from the interface lines (M7702) into the new address register.

The reset outputs from the new address register are applied to the subtractor and the invalid address detector. Using the reset outputs of the new address register effectively complements the new address. Thus, a 1's complement addition operation takes place in the subtractor.

If the new address register output is greater than 202, gate E15 of the invalid address detector is enabled and the ADDRESS INVALID L signal is generated. If this is the case, ADDRESS ACCEPTED L remains high, inhibiting the difference register and preventing the Forward or Reverse flip-flops from setting.

If the new address register output is equal to or less than 202, gate E15 is disabled and ADDRESS INVALID L remains high. This signal is ANDed at gate E17 (M7700) with the set output of the E18 strobe generator one-shot to produce the ADDRESS ACCEPTED L signal.

Simultaneously, the complemented new address register output is added, in the subtractor, to the output of the current address register. If, after the addition process, there is a low output at E26 pin 14, a carry condition has not occurred, and the positioner must either move the heads forward (toward the disk spindle) or retain the heads at their current location. To determine this fact, the subtractor output is inverted only for a no-carry condition by the E23, E28 exclusive-OR circuits. If the heads are to move forward, the high output from E18 (not zero) is ANDed at E13, with the inverted carry output, and applied to the data input of the Forward flip-flop.

When ADDRESS ACCEPTED L goes low, the Forward flip-flop sets, generating MOVE L and FWD H. FWD H is sent to the servo logic, placing it in velocity mode and initiating forward head motion (Paragraph 4.2.6.1). MOVE L sets the E13 positioner-settle-delay flip-flop (M7700) to accomplish the following:

- a. enable the seek-incomplete counter
- b. remove the R/W/S READY interface signal
- c. turn off the ON CYL indicator

The seek-incomplete counter begins to count INDEX pulses (40 ms repetition rate). If the counter reaches a count of seven (seek-incomplete condition), pin 12 comes high to set the seek-incomplete latch and generate the SEEK INCOMPLETE interface signal. To continue normal operation if this occurs, the controller must issue a return-to-zero (Restore) command or the operator must set the RUN/LOAD switch to LOAD and then back to RUN.

If a seek-incomplete has not occurred, and the distance from the present to the destination cylinder is greater than 31, an output from E18 (>31) configures the difference register (M7702) to a high-velocity binary output. This binary output is sent to the servo logic, to move the heads forward at high velocity.

NOTE

High velocity is when all stages of the difference register are cleared. Low velocity is when all stages are set.

As the read/write heads move across each track, output pulses (COUNT PULSE FWD H) from the position transducer are applied to gates E13 and E17. As long as the Reverse flip-flop remains reset, gate E13 is enabled, and each COUNT PULSE FWD H keeps the Forward flip-flop set. Concurrently, every output from E17 pin 3, increments the current address register, and the previously described addition process is repeated in the subtractor.

When the heads are 31 cylinders from the destination cylinder, gate E18 (>31) is disabled, permitting the difference register to be decremented directly by the decoded output of the subtractor. When the heads are 3 cylinders from the destination cylinder, gate E14 (≤ 3) is enabled and configures the difference register for a low-velocity binary output. The current address register continues to decrement until the heads are within one-half cylinder of the destination cylinder. At this point, E18 (not zero) is disabled, the Forward flip-flop resets, and FWD H and MOVE L are removed.

FWD H low places the servo logic in the detent mode (Paragraph 4.2.6.3), while MOVE L high triggers the 5-ms E19 positioner-settle-delay one-shot (M7700). When E19 times out, the E13 flip-flop resets, disabling the seek-incomplete counter, lighting the ON CYL indicator, and causing the R/W/S READY interface signal to go low. The drive is now ready to perform a read, write, or another seek operation.

4.2.5.3 Reverse Seek – A reverse seek is similar to a forward seek (Paragraph 4.2.5.2); however, if the current and new addresses are not alike, the subtractor (M7702) addition operation always results in a carry condition (high output at E26 pin 14). Because of this fact, gate E18 (not zero) is not used during this operation. The high carry output sets the Reverse flip-flop to allow the current address register to decrement.

NOTE

Due to unique timing considerations during the reverse seek, inverted count pulses are used to decrement the current address register.

If, during the initial power-on cycle, the heads are not fully retracted (unloaded), the “home” microswitch at the rear of the positioner is not made and the HOME L signal is high. HOME L is ANDed with LOAD HEADS L (high because the RUN/LOAD switch is in the RUN position) at gate E6 to generate REV H and MOVE L. Simultaneously, LOAD HEADS L high is applied to gate E1 to configure the difference register to a low-velocity binary output, thereby retracting the heads, at low speed, to the “home” position. At this position, the carriage contacts the “home” microswitch, causing the HOME L signal to go low, removing REV H and MOVE L.

Normally, the heads would not be over the disk during the initial power-on cycle. The preceding operation guarantees that the positioner does not move forward until the drive is placed in the run mode.

4.2.5.4 Return-to-Zero (Restore) Seek – In order to return the read/write heads to cylinder zero, the controller generates a RESTORE L signal, transmits a STROBE pulse, and simultaneously addresses the disk drive (Paragraph 4.2.4). SELECT/READY L is ANDed with STROBE L (M7700) to trigger the 150-ns E19 strobe generator one-shot. When E19 times out, E18 triggers, generating the GOOD STROBE L pulse and enabling pin 12 of gate E21.

RESTORE H, ANDed at gate E21 with the set output of E18, resets the seek-incomplete latch to remove the SEEK INCOMPLETE interface signal. RESTORE H also sets the RTZ flip-flop (M7702) to accomplish the following:

- a. clear the new address register
- b. clear the current address register
- c. set the Reverse flip-flop
- d. produce the RTZ L signal

RTZ L is applied to gate E7, pin 9, which resets the seek-incomplete counter and prevents it from incrementing.

When the Reverse flip-flop sets, REV H and MOVE L are generated. REV H is sent to the servo logic, placing it in the velocity mode, and initiating reverse head motion (Paragraph 4.2.6.1). MOVE L sets the E13 positioner-settle-delay flip-flop (M7700) to accomplish the following:

- a. remove the R/W/S READY interface signal
- b. turn off the ON CYL indicator

Because the current address register and the new address register have both been cleared, the result of the 1's complement addition, performed in the subtractor, produces a low output signal (no-carry condition) at E26 pin 14. The binary 0 from the subtractor is inverted by the E23, E28 exclusive-OR circuits, causing E14 (≤ 3) pin 6 to go low. This signal configures the difference register to a low-velocity binary output.

As the heads retract at low velocity, they pass cylinder zero and arrive at the outer limit of the recording disk. At this point, OUTER LIMIT H comes high to accomplish the following:

- a. reset the RTZ flip-flop
- b. set the outer-limit-extender latch, which holds the new and current address registers at zero
- c. reset the Reverse and set the Forward flip-flops

When the Forward flip-flop sets, gate E13 pin 1 is enabled and the heads begin to return toward cylinder zero. At this point, OUTER LIMIT H goes low, producing a low output at gate E13 pin 8. The next output pulse (COUNT PULSE REV H) from the position transducer (Paragraph 4.2.6), enables pin 2 of E13, resetting the Forward flip-flop, and removing FWD H and MOVE L.

FWD H low places the servo logic in the detent mode (Paragraph 4.2.6.3), while MOVE L high triggers the 5-ms E19 positioner-settle-delay one-shot (M7700). When E19 times out, the E13 flip-flop resets, disabling the seek-incomplete counter, lighting the ON CYL indicator, and causing the R/W/S READY interface signal to go low. R/W/S READY H also comes high at this time, clearing the outer-limit-extender latch.

If, during normal operation, the read/write heads reach the inner limit of the recording disk, INNER LIMIT H (M7702) comes high. This signal sets the RTZ and Seek-Incomplete flip-flops and automatically initiates a return-to-zero seek.

4.2.6 Position Servo Logic

The position servo logic (G938) controls the carriage velocity during a seek operation (velocity mode), or electronically detents the heads at a fixed cylinder location when a seek operation is not being performed (detent mode). The two inputs to the servo logic are generated from the linear position transducer and the cylinder address and difference logic.

The position transducer (Figure 4-11), located on the underside of the carriage, is an optical device consisting of two parts. The fixed portion (reticle) of the transducer is constructed in a U shape and is attached to the carriage slide. One side of the U contains a lamp while the other side contains a stationary reticle with minute diagonal transparent slots, plus six photo sensors connected in pairs. The movable portion (scale) of the transducer contains a section of minute vertical transparent slots, and is attached to the movable carriage. As the scale moves in the middle of the U-shaped reticle, the vertical and diagonal slots allow varying amounts of light to shine onto the photo sensors. This action produces two sinewave output signals that occur 90 degrees out of phase. These signals (SIN POSITION and COS POSITION) are applied to the servo logic. Two dc signals (INNER LIMIT and OUTER LIMIT) are also generated by the transducer. As long as the scale travel remains within the slotted section (cylinder 0 through 202), neither one of these signals is produced; however, when the scale reaches the inner travel extremity ($>$ cylinder 202), the inner limit photo sensor is uncovered and the negative INNER LIMIT signal is produced. The positive OUTER LIMIT signal is produced in a similar manner at the outer travel extremity ($<$ cylinder 0). Both signals are used in the position control logic during a seek operation (Paragraph 4.2.5).

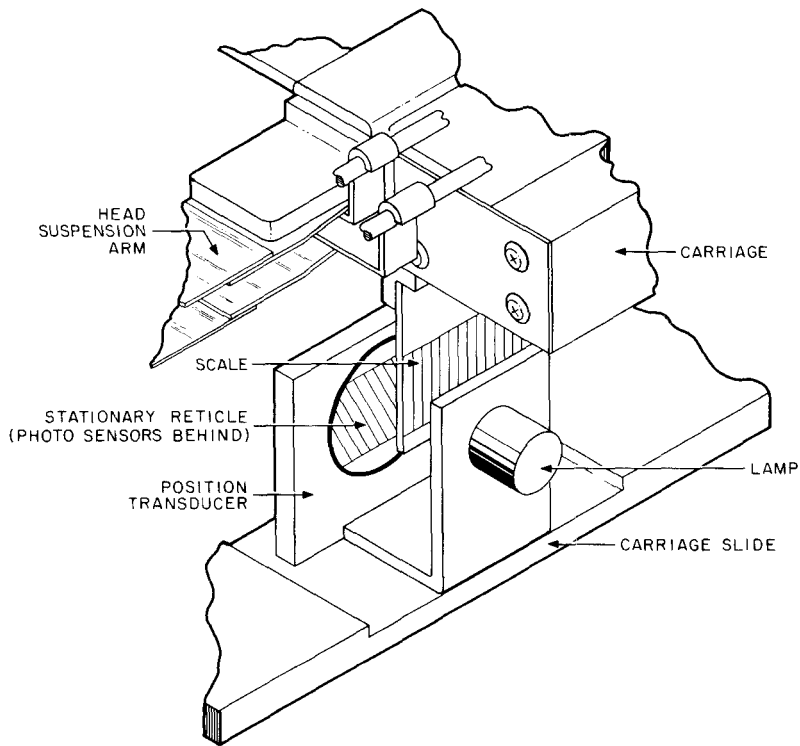

CP-0262

Figure 4-11 Linear Position Transducer

4.2.6.1 Velocity Mode – During a forward seek operation, FWD H is high (Paragraph 4.2.5.2). FWD H, applied to pin B-J2 (G938), causes transistor Q5 to conduct. With Q5 conducting, clamping diode D10 supplies 0V to the gates of FETs Q1 and Q3, causing them to conduct. As Q3 conducts, ground is applied to the junction of R22, R23, removing the SIN POSITION signal, and effectively releasing the electronic carriage detent.

Simultaneously, signals DIFF 1L through 16L from the difference register (Paragraph 4.2.5.2) are applied to the respective servo logic input pins. If the distance from the present to the destination cylinder is greater than 31 cylinders, DIFF 1L through 16L are all low. With an all low input, the output of “staircase generator” E12 pin 6 is maximum. This maximum output (approximately 5V) is fed through inverter E13, through the forward FET Q1, to amplifier E14 pin 2. With this input condition, a maximum +0.6V output of E15 pin 6 (limited by clamping diodes D15 and D16) is applied to pin 6 of the H604 module. The +0.6V input at pin 6 of H604 is applied through voltage divider R1, R2, and R14 to amplifier E1 pin 3.

NOTES

1. Resistor R14 is a calibration potentiometer that permits balancing of the voltage divider circuit.
2. Switch S1, when closed, applies ground to the input of amplifier E1, thus removing the voltage divider signal and permitting the carriage to be moved by hand.

The amplified output of E1 pin 6 is fed through preamplifier transistor Q1, through current driver Q3, to the armature of the linear motor, causing the carriage to accelerate forward at maximum velocity. (Transistors Q2 and Q4 apply a negative output to the linear motor for reverse motion.) As current flows through the armature, the

voltage drop across R13 in the return leg of the linear motor develops degenerative feed-back to amplifier E1, thus maintaining a constant 3A of current through the linear motor.

As the carriage moves forward across each track, two positive square-wave count pulse signals (COUNT PULSE FWD H and COUNT PULSE REV H), plus a velocity signal, are generated by the velocity synthesizer (Paragraph 4.2.6.2). The count pulse signals are applied to the cylinder address and difference logic to decrement the difference register, while the velocity signal is applied to amplifier E14 pin 2 to control the carriage speed. While the carriage is in motion, DIFF 1L through 16L remain low until the heads are 31 cylinders from the destination cylinder. At this point, the decrementing DIFF signals are applied to the “staircase generator”, reducing the generator output in discrete levels, and subsequently reducing the output of E14 pin 6. The four diode inputs (D1 through D4) to the “staircase generator” supply a varying reference voltage to ensure that the seek time during head positioning remains constant. This reference voltage automatically compensates for voltage changes due to age or deterioration of the transducer lamp and amplifier circuits.

As the E14 output lowers, the carriage decelerates until the distance to the destination cylinder is 3 cylinders. At this point, all inputs to the “staircase generator” go high, and the output at E12 pin 6 is minimum. This minimum output (approximately 0.5V) allows the carriage to travel the remaining distance to the destination cylinder at low velocity. One-half cylinder prior to the destination cylinder, FWD H goes low, turning off Q5 and applying -15V to the gate of FETs Q1 and Q3. With Q3 off, ground is removed from the junction of R22, R23, and the SIN POSITION signal again electronically detents the carriage at the destination cylinder.

During a reverse seek operation, REV H causes transistor Q6 to conduct, turning on FETs Q2 and Q4. With Q2 conducting, the “staircase generator” output is applied, without inversion, directly to amplifier E14. The preceding description of a forward seek then occurs for a reverse seek, except that the output of E14 pin 6 is negative, moving the carriage in reverse, and COUNT PULSE REV H occurs prior to COUNT PULSE FWD H.

4.2.6.2 Velocity Synthesizer – In a closed loop servo system, a degenerative feed-back control signal is required to prevent uncontrolled velocity within the system. In the RK05 Disk Drive, this control or tachometer signal is derived in the velocity synthesizer (G939).

As the carriage accelerates, the SIN POSITION and inverted COS POSITION signals from the position transducer are applied through amplifiers E6 and E10 to summing junction R35, R36. Simultaneously, the SIN POSITION and COS POSITION signals are applied through amplifiers E6 and inverter E11 to summing junction R38, R39. Amplifier outputs E6, E10 and inverter outputs E7, E11 are also applied through differentiator circuits R57–R70, C2–C5 to related FETs Q11–Q14. Thus, as the carriage velocity increases, the differentiator output amplitude increases in direct proportion to the velocity. The resultant signal from sum junction R35, R36 (Figure 4-12, Sum Junction R35, R36) leads the SIN POSITION signal by 45 degrees and, conversely, the resultant signal from junction R38, R39 (Figure 4-12, Sum Junction R38, R39) lags the SIN POSITION signal by 45 degrees. Both of these resultant signals are then fed to overdriven, zero crossover detectors E3 and E4, producing a square-wave transition for each zero crossing (Figure 4-12, Zero Crossover Dets). These square-wave signals are clipped by Zener diodes D21, D22, and then are applied directly, as well as through E1 inverters (Figure 4-12, Inverters), to gating circuit E5.

This unique gating scheme produces four separate square-wave signals (Figure 4-12, Gating Scheme) such that, collectively, there are four sampling periods during any one cycle of the SIN POSITION signal. Two of these square-wave signals (E5 pins 3 and 8) occur during each half cycle of the SIN POSITION signal and generate the COUNT PULSE FWD H and COUNT PULSE REV H signals respectively. Thus, for each cylinder of travel, the sinusoidal SIN POSITION signal is converted into two positive square-wave count pulse signals. In addition, the E5 square-wave signals are applied to transistors Q7–Q10, causing the corresponding FETs Q11–Q14 to alternately conduct. This action allows only the peak portions of the differentiated signals (Figure 4-12, Differentiators) to be applied

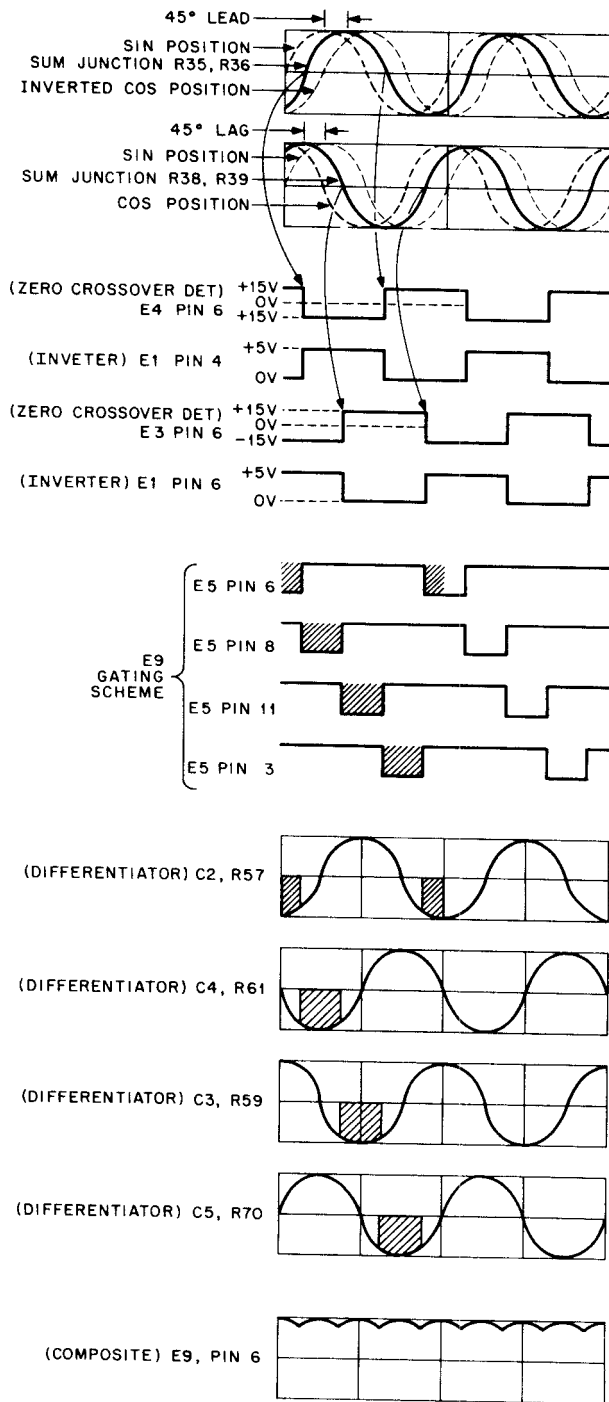

CP-0256

Figure 4-12 Velocity Synthesizer Timing

to inverter E9, producing a degenerative composite output (Figure 4-12, Composite) that is similar to full-wave rectification of both the SIN POSITION and COS POSITION input signals. This degenerative signal is then coupled to amplifier E14 pin 2 to control the output amplitude of the amplifier with respect to the carriage velocity. Thus, as the carriage accelerates, inverter E9 pin 6 output increases until the degenerative signal exactly balances the “staircase” input. At this point, further acceleration is inhibited and a constant carriage velocity is maintained.

4.2.6.3 Detent Mode – The detent mode of operation retains the read/write heads over a desired cylinder. When the carriage is stationary, a 0V SIN POSITION signal from the position transducer is applied to pin A-N1 (G938). This signal is then fed through amplifier E6, through resistors R23, R22, to amplifier E14 pin 2. With this input condition, a 0V output of E14 pin 6 is applied to pin 6 of the H604 module, and no carriage motion occurs. If the carriage deviates from the desired cylinder, a positive or negative signal (depending upon the direction of deviation) is coupled through R23, R22, to amplifier E14. The E14 pin 2 output then goes positive or negative, moving the carriage back to the desired cylinder. The preceding action is instantaneous; therefore, only a minute amount of carriage movement actually occurs.

4.2.7 Sector/Index Pulse Generation

In order to read or record data with specific formats (e.g., data blocks) as well as retrieve or store data at designated areas (sectors) on the disk, a timing scheme related to the rotational position of the disk is required. The SECTOR and INDEX pulses are used to accomplish this. These pulses are generated by slots in the recording disk hub that pass through a groove in the sector transducer. There are 12 equally spaced sector slots, designating the 12 sectors on the disk, and one uniquely spaced index slot, designating one complete revolution (start of sector 0). Because both the SECTOR and INDEX pulses are produced from a single transducer, logic on the M7700 card separates these two pulses and also encodes the sector address.

The sector transducer, located directly in front of the spindle, is an optical device that contains a light-emitting diode and a photo sensor. As the recording disk rotates, the slots pass between the light-emitting diode and the sensor, producing negative SECTOR/INDEX pulses (Figure 4-13). These pulses are applied to pin A-E1 (M7700) causing transistor Q1 to conduct and trigger the E2 sector timing one-shot.

The capacitive feed-back circuit from the emitter to the base of Q1 prevents noise spikes from triggering E2. The E2 output can be adjusted by varying R6, which varies the SECTOR pulse timing. This adjustment compensates for different sector transducer locations within various disk drives. Thus, when disk cartridges are interchanged, each data record is properly located with respect to the associated SECTOR pulse.

When E2 times out, the E6A sector/index pulse generator one-shot triggers. The set output of E6A is applied to gates E7, E11, and the 2-ms E6B index separator one-shot. At this point, gate E7 pins 4 and 5 are enabled and the SECTOR L signal is produced which increments the 4-stage sector address counter. If the drive is ready and has been addressed (Paragraph 4.2.4), SELECT/READY L accomplishes the following:

- a. enables gate E11 which causes the SECTOR PULSE interface line to go low
- b. enables gates E5 and E17, to produce the binary SECTOR ADDRESS interface signals

If the drive has not been addressed, the SECTOR L signal is still produced to increment the sector address counter; however, the SECTOR PULSE and SECTOR ADDRESS interface signals are not generated. The preceding events are repeated for every sector slot on the disk hub.

The occurrence of the last SECTOR pulse (sector 11) triggers the E6A SECTOR/INDEX pulse generator as before; however, 600 μ s later, the index slot on the disk hub causes E6A to trigger again. The set output of E6A is then ANDed at gate E7 pins 1 and 2 with the set output of E6B (still high from the previous triggering) to produce the

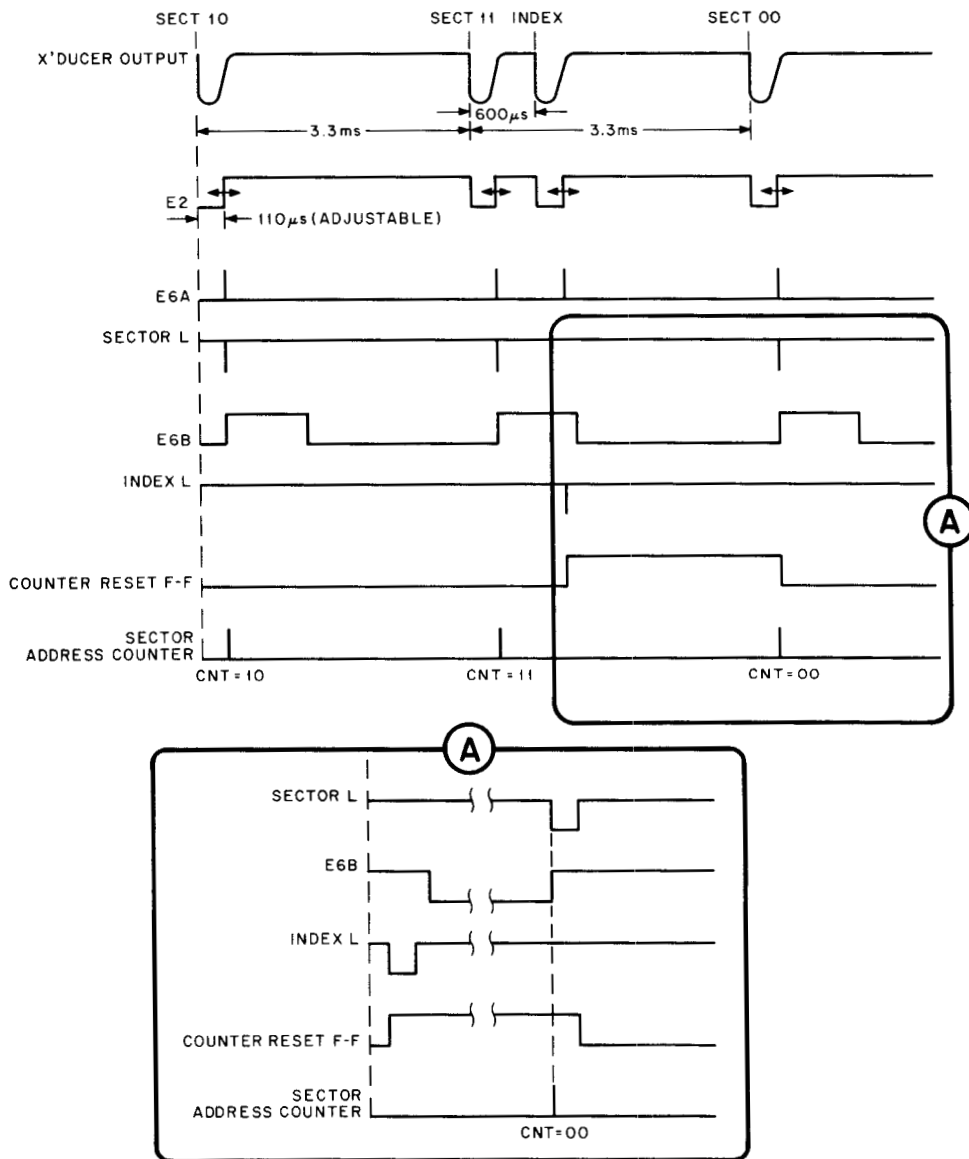

CP - 0261

Figure 4-13 Sector/Index Timing

INDEX PULSE L signal. INDEX PULSE L sets the Counter Reset flip-flop and also causes the INDEX PULSE interface line to go low. The set output from the Counter Reset flip-flop enables pin 2 of the sector address counter. (Pins 2 and 3 of the sector address counter are AND gate inputs.)

The leading edge of the next SECTOR pulse (sector 0) is inverted at E20 pin 12 to reset the sector address counter, while the trailing edge of the sector 0 pulse is applied to the clock input of the Counter Reset flip-flop, causing it to reset.

If the drive has not been addressed, the preceding events still occur; however, the respective interface signals are not generated.

4.2.8 Read Operation

To initiate a read operation, the controller:

- a. addresses a particular drive by causing one of the SELECT interface lines to go low (Paragraph 4.2.4)
- b. positions the read/write heads at the appropriate cylinder via the binary coded CYLINDER ADDRESS interface lines (Paragraph 4.2.5)
- c. selects either the upper or lower read/write head by causing the HEAD SELECT interface line to come high or go low (Paragraph 3.2.4)

If the lower read/write head is to be used, HEAD SELECT (G180-0-1) comes high. This signal is ANDed, at gate E6 pins 7 and 6, with UNSAFE L (high, if no fault condition exists) (Paragraph 4.2.10). This action applies a ground potential at pin 7 (center tap) of the lower head.

As flux reversals on the disk surface pass under the lower read head, induced current flows from pins 7 to 5 or 7 to 8 of the lower read coil. The direction of current flow depends upon the polarity of the flux reversal. These small read signals (approximately 5 mV) are transmitted through the head-select diode (D5 or D25), through the series-isolation diodes (D11, D13 or D12, D14), to differential read preamplifier E13 pins 1 and 14. The diode, resistor, and capacitive network between the read/write coils and the read preamplifier automatically isolates the preamplifier from the large write signals during a write operation; however, it allows the small read signals during a read operation to pass.

The amplified output of E13 pins 7 and 8 (approximately 300 mV) is transmitted through a low-pass filter network to differential read amplifier E14 pins 1 and 14. The filter network removes noise and high-frequency disturbance, but permits the power-frequency head signals to pass. The amplified output of E14 pins 7 and 8 (approximately 3.0V) (Figure 4-14, TP3 and 4) is applied to balanced delay circuits L6, C20, and C21. Here the signal is differentiated and converted into zero crossings (Figure 4-14, TP5 and 6). The complementary zero crossings are then applied to Schmitt trigger E11 pins 5 and 6, producing a square-wave output with a transition for each zero crossing (Figure 4-14), E11 pin 8). This square-wave output is transmitted through emitter follower Q5, through differentiator E27, R49, to Schmitt trigger E11 pins 12 and 13. The 100-ns pulse train output (Figure 4-14, TP2) of E11 pin 1 is applied to gate E4 pins 2 and 4.

At this point, data and clock pulses are separated from the pulse train. To simplify the following discussion, assume that flip-flop E3B remains set, keeping E10 pin 3 high. If the Data Separator flip-flop E3 is reset when the leading edge of the first pulse on the pulse train occurs, gate E4 pins 4 and 5 are enabled. Because the drive is selected (Paragraph 4.2.4), SELECT/READY L is ANDed at gate E2 pins 11 and 12 with the READ GATE interface signal, thus enabling gate E1 pin 6 and also generating the SELECTED READ GATE H signal. The low output from E4 pin 6 produces the READ CLOCK L interface signal, and is also applied to the inverter input of data window one-shot E10. This action triggers the one-shot to produce a low output at E10 pin 6 (Figure 4-14) that disables gate E4 pin 12. Integrator circuit R57, C30 allows the comparison of the data window frequency to an established reference voltage at amplifier E5 pins 2 and 3. The E5 output is then applied through D22 to the adjustable input of E10. This practice automatically varies the one-shot frequency to compensate for variances in the pulse train width, and thus maintains the correct data window to pulse train/time relationship.

When the trailing edge of the first pulse on the pulse train occurs (100 ns after the leading edge), E4 pin 6 comes high and sets the Data Separator flip-flop E3. Approximately 300 ns after E3 sets (slightly more than one-half bit cell), E10 times out and gate E4 pin 12 is enabled. If another pulse on the pulse train has not occurred by this time (data 0 bit), E4 pin 13 is high and the Data Separator flip-flop E3 resets. If another pulse on the pulse train has occurred (data 1 bit), the leading edge of this pulse enables gate E4 pin 2, generating the READ DATA L interface signal, as well as disabling E4 pin 13. The trailing edge of this data 1 pulse causes E4 pin 13 to come high 100 ns later and resets the Data Separator flip-flop E3.

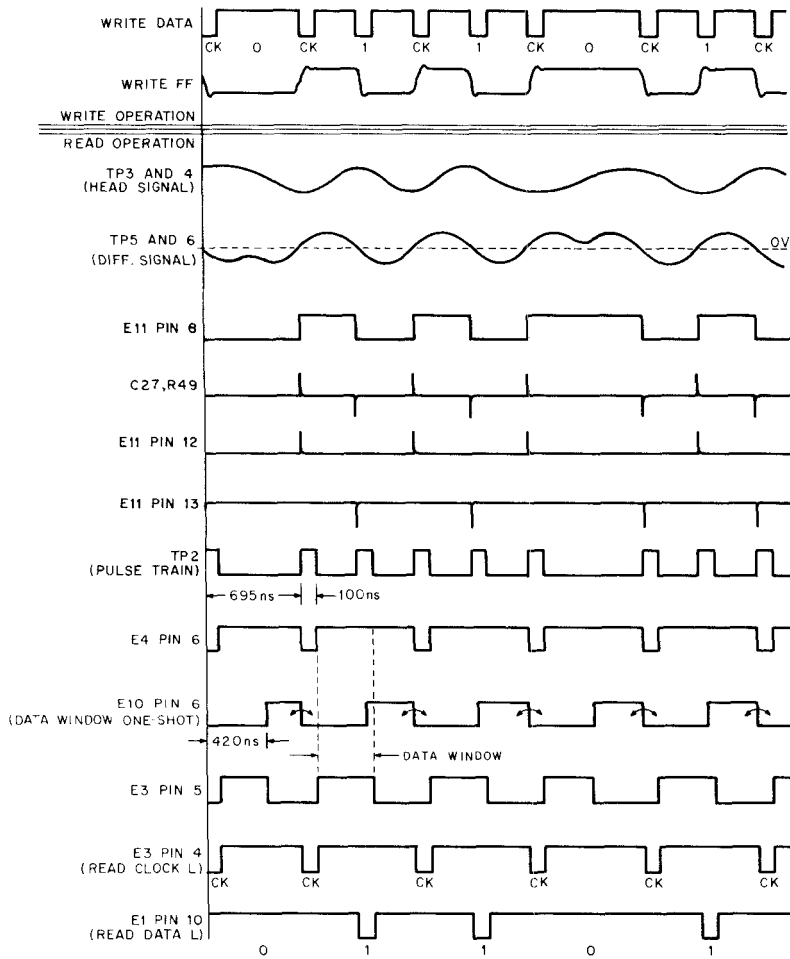

NOTE:
The illustrated wave forms represent the read operation time relationship only and do not necessarily depict the true wave form amplitude.

CP-0255

Figure 4-14 Read Timing

Generally, the E10 one-shot does not time out until after a complete data 1 pulse has occurred. Under these conditions, the E10 output resets the Data Window flip-flop. If E10 times out during the occurrence of a data 1 pulse, the Data Window flip-flop does not reset until the data 1 pulse expires. To accomplish this, an additional circuit is used to control the E10 timing. If the data bit is a 1, this pulse sets E3B and allows the following CLOCK pulse to trigger E10. As soon as E10 triggers, E3A is reset by the signal from E4 pin 8. If the data bit is a 0, E3A must first be triggered by the clock from E2 pin 3 before E10 can be triggered. Thus, the one-shot is slightly delayed, causing the trailing edge of the Data Window flip-flop E3A to be delayed a corresponding amount. This practice ensures that a partial data pulse does not occur at the interface.

4.2.9 Write Operation

To initiate a write operation, the controller:

- a. addresses a particular drive by causing one of the SELECT interface lines to go low (Paragraph 4.2.4)
- b. positions the read/write heads at the appropriate cylinder via the binary coded CYLINDER ADDRESS interface lines (Paragraph 4.2.5)
- c. selects either the upper or lower read/write head by causing the HEAD SELECT interface line to come high or go low (Paragraph 3.2.4)

If the lower read/write head is to be used, HEAD SELECT (G180-0-1) comes high. This signal is ANDed, at gate E6 pins 7 and 6, with UNSAFE L (high, if no fault condition exists) (Paragraph 4.2.10). This action applies a ground potential at pin 7 (center tap) of the lower head.

At this point, the controller transmits the WRITE GATE L signal. WRITE GATE L is ANDed, at gate E8 pins 9 and 10, with SELECT/READY L to generate the signal SELECTED WRITE GATE H. This signal enables pin 2 of both gates E7 and E9.

The multiplexed data to be recorded is then transmitted over the WRITE DATA AND CLOCK interface line. If the WT PROT switch is off (drive not write-protected), NO PROTECT L is low to accomplish the following:

- a. AND with R/W/S READY to enable gate E9
- b. AND at gate E8 pins 11 and 12, with the incoming data

With E9 enabled, Zener diode D2 conducts, applying +10V to pin 7 of complementary Write flip-flop E11, completing the base current return circuit for write drivers Q1 or Q2. In effect, regardless of the other input conditions, E9 must be enabled before write current can flow through the read/write heads.

NOTE

Flip-flop E11 operates between +10 and +15V, instead of ground and +5V.

When the WRITE DATA or CLOCK pulse goes low, gate E7 is enabled, complementing the Write flip-flop. The low reset output of the Write flip-flop (E11 pin 6 = +10V), applied to the base of transistor Q2 (write driver), causes it to conduct, thus allowing approximately 35 mA of current (adjustable with R13) to flow from pins 7 to 5 of the lower write coil. With Q2 conducting, a low voltage is applied to the base of transistor Q3 (erase current switch), causing it to conduct. When Q3 conducts, gate E9 pin 7 is enabled (Paragraph 4.2.10.1) and current flows from pins 7 to 6 of the lower erase coil.

When the WRITE DATA or CLOCK pulse goes low again, the Write flip-flop complements, causing transistor Q1 (write driver) to conduct and Q2 to cut-off. Approximately 35 mA of reverse current now flows from pins 7 to 8 of the lower write coil; however, the current direction in the lower erase coil remains constant. With each current reversal in the write coil, a flux reversal is recorded on the rotating disk surface.

4.2.10 Fault Detection

If the following two fault conditions are detected during normal operation, all external commands to the drive are suppressed and the FAULT indicator on the drive control panel lights. The fault conditions are:

1. erase or write current without a WRITE GATE
2. head position transducer lamp inoperative

4.2.10.1 Erase Current Fault – During a write operation, write driver Q1 or Q2 (G180-0-1), depending upon the input data polarity, is conducting. Either write driver output turns on Q3 (erase current switch) and enables pin 7 of gate E9. With the WRITE GATE L signal low, pin 6 of E9 is disabled and Q4 conducts, keeping SET UNSAFE L high.

If, for any reason (e.g., shorted transistor), the erase current switch should conduct without a WRITE GATE L signal present, gate E9 is enabled. This action turns off Q4 and causes the SET UNSAFE L signal to go low. SET UNSAFE L low accomplishes the following:

- a. sets the fault latch (M7701)
- b. generates the WRITE CHECK interface signal and lights the FAULT indicator (M7701)
- c. deselected both read/write heads (G180-0-1)

4.2.10.2 Positioner Lamp Fault – This fault condition can only be detected when the read/write heads are in the “home” position. If the positioner lamp fails at any other time, various other checks will disclose this fact (e.g., SEEK INCOMPLETE generated, or R/W/S READY never generated, etc.). Therefore, the positioner lamp check is accomplished on the initial power-on cycle, or, if the heads move back to the “home” position after having once been loaded.

If the lamp fails and the heads are in the “home” position, HOME H (M7701) is high; however, OUTER LIMIT H (heads at or beyond the outer portion of the disk) is low. This signal combination enables gate E7 and sets the fault latch. When the fault latch sets, the FAULT indicator lights and the WRITE CHECK interface signal is generated.

4.3 POWER SUPPLY DESCRIPTION

The RK05 Disk Drive power supply (H743) and associated electronic cards are located in the left rear portion of the disk drive. The power supply itself can be operated from a 115 or 230 Vac line voltage input and consists of a dual transformer, two bridge rectifiers, and three voltage regulators. For 115 Vac operation, two jumpers must be connected to P2 pins 1 and 2, and P2 pins 3 and 4. This configuration connects the dual primaries of transformer T1 in parallel. For 230 Vac operation, only one jumper must be connected to P2 pins 2 and 3. This configuration connects the dual primaries of transformer T1 in series, thus maintaining 115 Vac across each primary. With either configuration, the 115 Vac blower motor is connected across T1 pins 1 and 2, while the 115 Vac spindle motor is connected across T1 pins 3 and 4.

When the power supply is activated, the secondary output of T1 pins 7 and 8 is applied through full-wave bridge rectifier D2, across capacitor C2, to the input of both the +15V and +5V regulators. The other T1 secondary output is likewise applied through full-wave bridge rectifier D1, across capacitor C1, to the input of the -15V regulator. The regulator outputs are maintained within the following specified voltage limits:

- a. $+15 \pm 0.75$ Vdc
- b. -15 ± 0.75 Vdc
- c. $+5 \pm 0.15$ Vdc

All three regulators contain current-limiting circuitry and are further protected against short circuits by a permanent fuse. Only the +5 Vdc regulator (logic power) contains a nonadjustable crowbar circuit for automatic over-voltage protection.

CHAPTER 5

MAINTENANCE

5.1 RECOMMENDED TOOLS AND TEST EQUIPMENT

Table 5-1 lists the recommended tools and test equipment that are to be used with the standard tools for proper maintenance of the RK05 Disk Drive.

Table 5-1
Recommended Tools and Test Equipment

Equipment	Manufacturer and Model/Part No.
Multimeter	Triplet 310 or Simpson 360
Oscilloscope	Tektronix 453
Oscilloscope Probes	
Voltage	Tektronix P6010
Current	Tektronix P6019 clip-on with passive terminator
Wire Wrap Tool (24-gauge)	DEC H811
Unwrapping Tool (24-gauge)	DEC H812
Wire Wrap Tool (30-gauge)	DEC H811A
Unwrapping Tool (30-gauge)	DEC H812A
Module Extender Board	DEC H982
Head Cleaning Kit	
Tex Pads	29-19557
Wand	29-19558
Inspection Mirror	29-19663
Isopropyl Alcohol	29-19665
Q-Tips	90-08436
0.005-in. Blue Shim Stock	29-19664

5.2 PREVENTIVE MAINTENANCE

When the disk drive is operated in a normal office environment on a one shift basis, perform the preventive maintenance (PM) procedures as indicated in Table 5-2. An abnormally dirty environment or a high incidence of cartridge exchange may require more preventive maintenance than that indicated in the schedule. During the PM procedures, unless specifically indicated, do not alter any adjustments on drives that are performing satisfactorily.

**Table 5-2
Preventive Maintenance Schedule**

Frequency (hours)	Area	Action	Reference
500	Read/Write Heads	Clean – heavy operation (e.g., extensive cartridge exchange with frequent starts and stops. Frequent use of virgin cartridges).	Paragraph 5.2.2
1,000	Read/Write Heads	Clean – medium operation	Paragraph 5.2.2
1,500	Read/Write Heads	Clean – light operation (e.g., minimum cartridge exchange with infrequent starts and stops.	Paragraph 5.2.3
	Prefilter	Clean	Paragraph 5.2.3
	Spindle	Clean	Paragraph 5.2.3
		Check for bearing noise	Paragraph 5.2.3
3,000	Prefilter	Replace	Paragraph 5.2.5
	Absolute Filter	Replace	Paragraph 5.2.6
	Spindle Belt Tension	Check	Paragraph 5.2.4
6,000	Linear Positioner	Inspect flexstrip for cracks in copper leads. Check ease of forward and backward motion. Check for excessive lateral motion. Check velocity profile (64 cylinder seek waveform).	Paragraph 5.3.2.6
	Read/Write Heads	Check head alignment.	Paragraph 5.3.3.3
7,500	Spindle Ground	Check contact with ohmmeter	
15,000	Spindle Ground	Remove spindle and replace ground assembly.	Paragraph 5.3.4
	Spindle Drive Belt	Replace and clean pulleys.	Paragraph 5.3.6
	Blower	Remove and clean impeller.	Paragraph 5.3.7
30,000	Spindle	Replace	Paragraph 5.3.4
	Spindle Motor	Replace	Paragraph 5.3.5
	Blower Motor	Replace	Paragraph 5.3.7
	Linear Transducer	Clean scale, reticle, and lens with 91% isopropyl alcohol	

5.2.1 Elapsed Time Indicator

The elapsed time indicator (Figure 5-1), located on the rear of the disk drive, indicates the number of hours that the drive has been operating. When power is applied to the drive, a bubble indicator moves from left to right within a mercury column. The movable scale beneath the bubble is graduated in 200-hour increments and furnishes

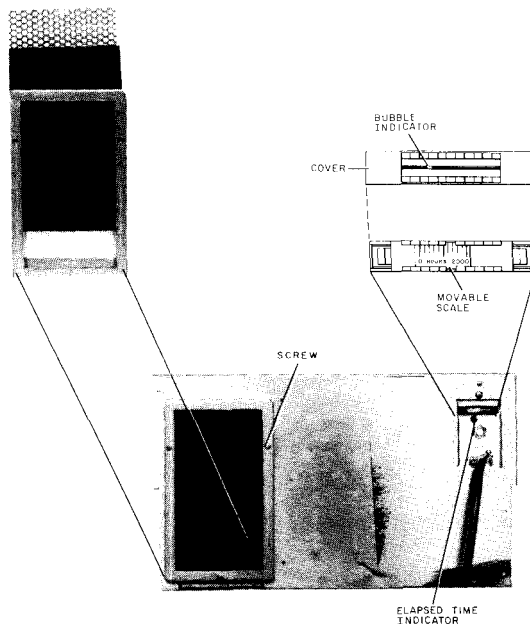

Figure 5-1 Prefilter Removal

a direct hour read-out. When performing the 1500-hour preventive maintenance procedures, record the data and the elapsed time indication in the maintenance log book and reset the indicator as follows:

1. Remove the top cover of the elapsed time indicator and rotate the cover so that the bubble is in the left portion of the cover.
2. Place the cover (back-side up) against the movable scale.
3. Using a pocket screwdriver, slide the movable scale until the zero reference mark is aligned with the bubble.
4. Turn the cover right-side up and recheck the zero reference alignment.
5. Snap the cover into place.

5.2.2 500-Hour PM Procedure

1. Remove the disk cartridge from the drive.
2. Press the ON/OFF switch to OFF and disconnect the ac line cord.
3. Inspect the read/write heads for excessive dirt or oxide. If necessary, clean the heads with the wand and tex pads supplied with the Head Cleaning Kit. If the cleaning kit is not available, the heads may be cleaned with a Q-tip soaked in 91% isopropyl alcohol. Dry the heads with a clean, dry Q-tip.
4. Restore the drive to normal operation.

5.2.3 1,500-Hour PM Procedure

1. Remove the disk cartridge from the drive.
2. Press the ON/OFF switch to OFF and disconnect the ac line cord.
3. Record the elapsed time indication in the maintenance log and reset the elapsed time indicator (Paragraph 5.2.1).

(continued on next page)

4. Inspect and clean the read/write heads if required (Paragraph 5.2.2, Step 3).
5. Vacuum the prefilter outer face (Figure 5-1). If there is excessive dirt on the prefilter, remove the filter (Paragraph 5.2.5) and clean it with a mild liquid detergent (e.g., Ivory) and warm water. Using the vacuum cleaner exhaust, air-dry the filter completely before installation.
6. Remove the flexible magnet from the spindle and clean the armature plate with a clean cloth moistened with 91% isopropyl alcohol. Using the sticky side of some masking tape, remove any metallic particles from the armature plate. Reinstall the flexible magnet.
7. Restore the drive to normal operation and check for excessive spindle bearing noise while the spindle is rotating. Replace the spindle (Paragraph 5.3.4) if excessive noise occurs.

5.2.4 3,000-Hour PM Procedure

1. Remove the disk cartridge from the drive.
2. Press the ON/OFF switch to OFF and disconnect the ac line cord.
3. Inspect and clean the read/write heads if required (Paragraph 5.2.2, Step 3).
4. Replace the prefilter (Paragraph 5.2.5).
5. Replace the absolute filter (Paragraph 5.2.6).
6. Check the spindle drive belt tension by squeezing the belt together and ensuring that, when the belt is released, the tension spring restores the motor mounting plate enough to keep tension on the belt. If not, replace the belt (Paragraph 5.3.6).
7. Restore the drive to normal operation.

5.2.5 Prefilter Removal and Replacement

1. Press the ON/OFF switch to OFF.
2. Open the rear door of the rack.
3. Remove the three screws attaching the prefilter retainer to the drive (Figure 5-1) and remove the filter.
4. Install a new filter in the retainer, ensuring that the screen is behind the filter as shown in Figure 5-1.
5. Position the retainer with the screen against the drive and secure it with the previously removed hardware.
6. Close the rear door and apply power.

5.2.6 Absolute Filter Removal and Replacement

1. Press the ON/OFF switch to OFF.
2. Open the rear door of the rack and disconnect the ac line cord.
3. Slide the drive out of the rack until it locks in the extended position.
4. Remove the bottom and plenum covers (Figure 5-2).
5. Remove the absolute filter.
6. Install a new filter with the arrow (air flow) pointing away from the blower outlet. Ensure that the filter is positioned between the two tabs and that the rubber seal is in the baseplate recess.
7. Replace the plenum and bottom covers.
8. Slide the drive into the rack and connect the ac line cord.
9. Close the rear door and apply power.

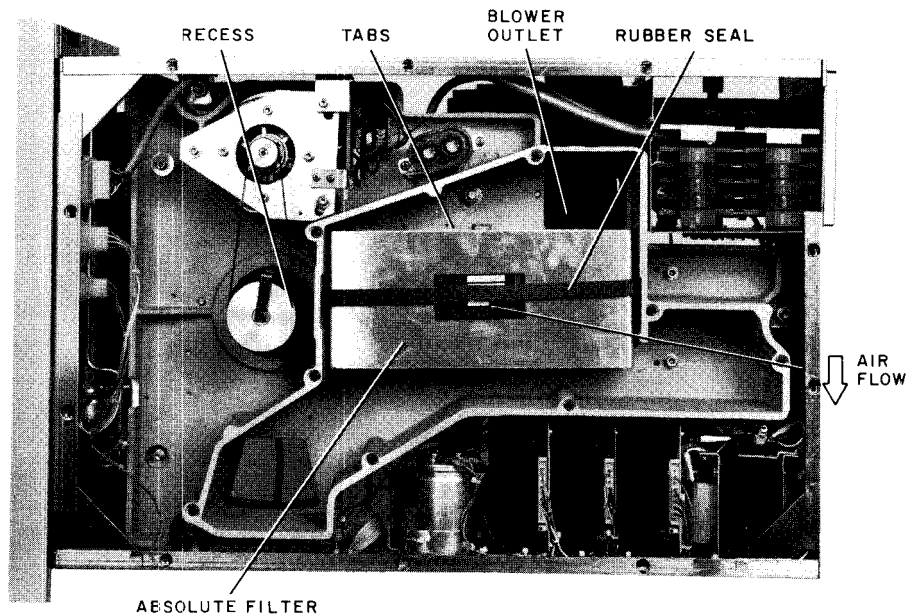

Figure 5-2 Absolute Filter Removal

5.3 CORRECTIVE MAINTENANCE

5.3.1 Linear Positioner

5.3.1.1 Positioner Removal

1. Remove the disk cartridge from the drive.
2. Press the ON/OFF switch to OFF.
3. Open the rear door of the rack and disconnect the ac line cord.
4. Slide the drive out of the rack until it locks in the extended position.
5. Remove the top, bottom, and plenum covers.
6. Unplug connector J5 (Figure 5-3) from the power supply chassis.
7. Remove the position transducer wires from TB1 pins 1 through 9 and TB2 pins 8 and 9.
8. Disconnect the head connectors from the electronic module.
9. Remove the absolute filter (Figure 5-2).
10. Remove the three screws, beneath the baseplate, attaching the positioner to the baseplate (Figure 5-4).
11. Carefully maneuver the positioner off the locating pins on top of the baseplate and lift the positioner straight up from the baseplate.

5.3.1.2 Positioner Replacement

1. Carefully place the positioner on the three locating pins on top of the baseplate (Figure 5-3). Ensure that the two front pins rest against the front surface of the motor housing and the third diamond shaped pin is in the centerhole of the mounting face.

(continued on next page)

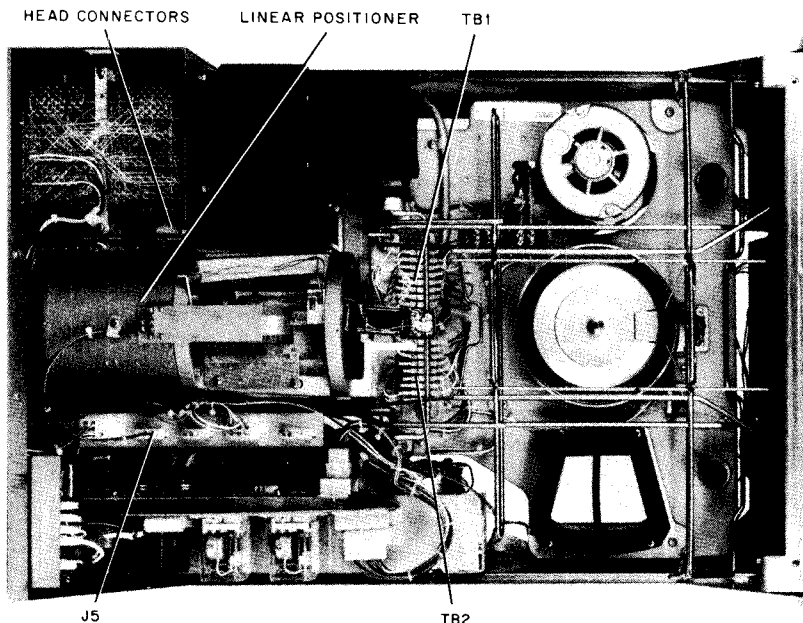

Figure 5-3 Top View with Cover Removed

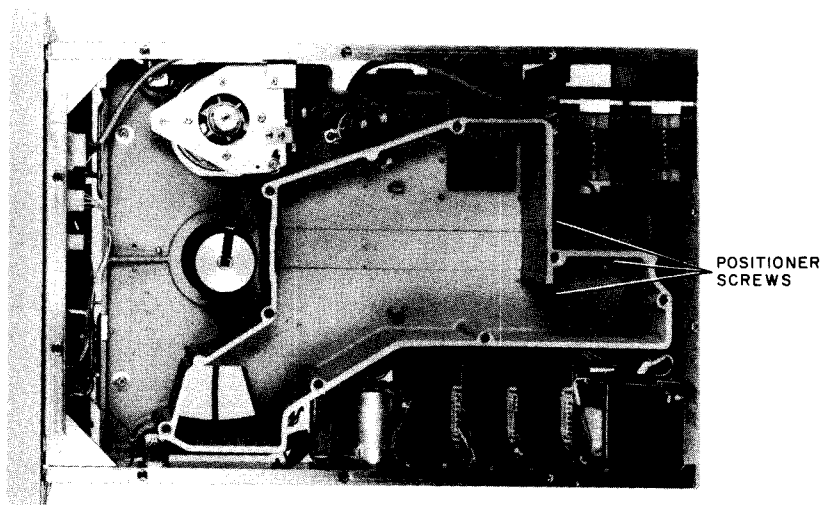

Figure 5-4 Bottom View with Covers Removed

2. Insert the three positioner holding screws (Figure 5-4) through the bottom of the baseplate and finger tighten the screws.
3. Ensure that the positioner is located securely against the front locating pins by tightening the holding screws while applying forward pressure to the rear of the positioner.
4. Check with a feeler gauge for less than .002-in. clearance between the front of the motor housing and the baseplate. If the clearance is not less than .002 in., loosen the positioner holding screws and repeat Step 3.

(continued on next page)

5. Connect the position transducer wires to TB1 and TB2 (Figure 5-3).

NOTE

Refer to the chassis wiring drawing for TB1 and TB2 connection color code.

6. Plug connector J5 into the power supply chassis.
7. Connect the head leads to the electronic module. Refer to the decal on the electronic module for the correct lead connections.
8. Install the absolute filter with the arrow (air flow) pointing away from the blower outlet (Figure 5-2). Ensure that the filter is positioned between the two tabs and that the rubber seal is in the baseplate recess.
9. Replace the plenum and bottom covers.
10. Connect the ac line cord and check the read/write head alignment (Paragraph 5.3.3.3).
11. Replace the top cover.
12. Close the rear door and apply power.
13. Install a test cartridge and exercise the drive.

5.3.2 Carriage

5.3.2.1 Carriage Removal

1. Remove the linear positioner (Paragraph 5.3.1.1).
2. Remove the read/write heads (Paragraph 5.3.3.1).
3. Remove the four flexstrip connector and flexstrip holddown screws (Figure 5-5). Do not disconnect the flexstrip coupling from the armature.
4. Remove the cable clamp screw from the top of the motor housing.
5. Remove the home switch and bracket from the carriage slide.
6. Remove the five screws securing the carriage slide to the motor housing.
7. Slowly pull the carriage and slide straight out from the motor housing.
8. Slide the carriage and armature out from the back of the carriage slide, ensuring that the transducer block does not contact the glass scale.

5.3.2.2 Carriage Replacement

1. Carefully insert the armature and carriage into the carriage slide, ensuring that the transducer block does not contact the glass scale.
2. Insert the armature and carriage slide into the motor housing, ensuring that the dowel pin on the housing goes into the "V" groove on the carriage slide.
3. Replace the five screws that secure the carriage slide to the motor housing (Figure 5-5).
4. Loop the flexstrip onto the top of the motor housing and replace the four flexstrip connector and holddown screws.
5. Replace the cable clamp.
6. Replace the home switch and bracket on the carriage slide.

(continued on next page)

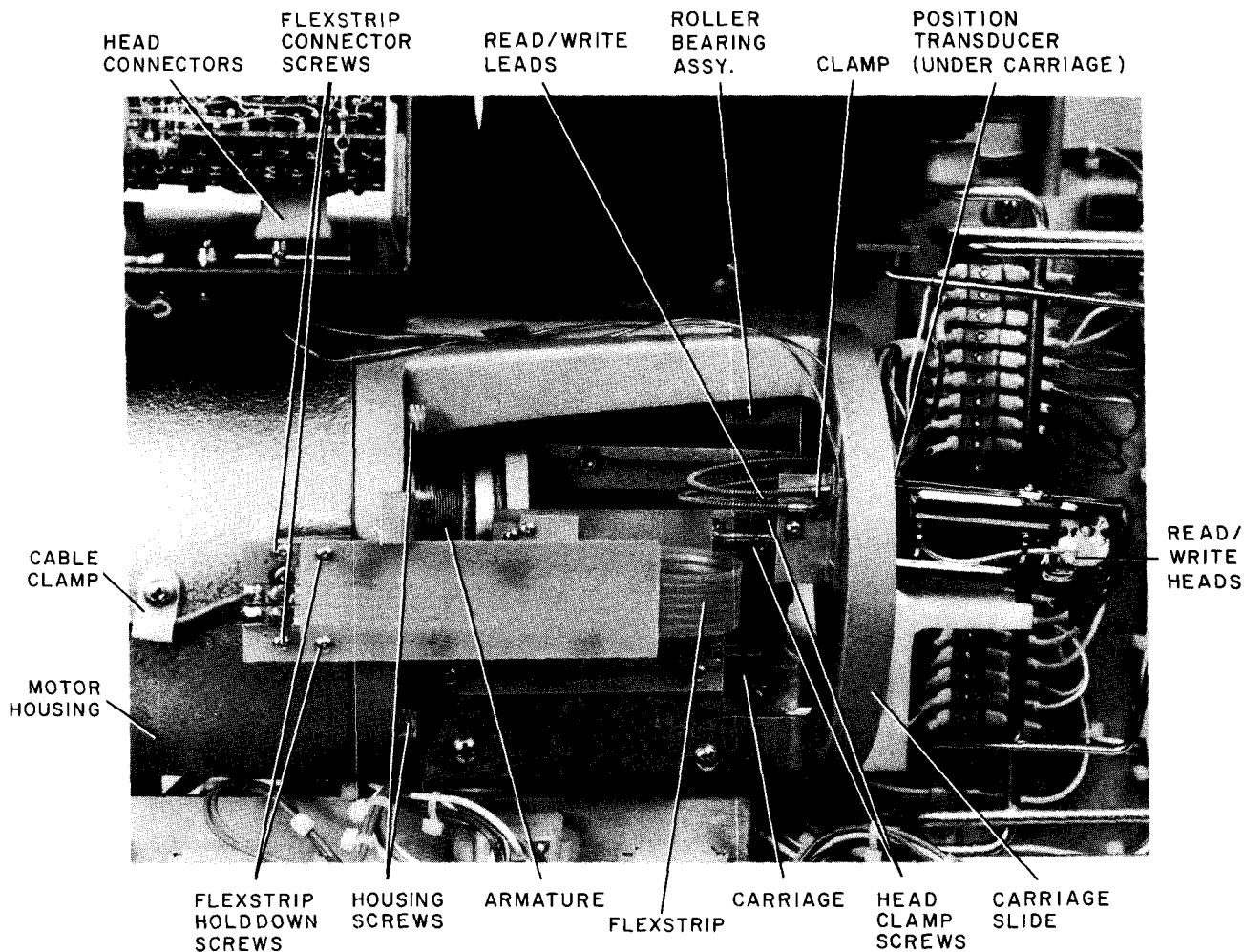

Figure 5-5 Carriage Removal

7. Stand the positioner up on the motor housing end, and adjust the home switch as follows:
 - a. Pull the carriage out from the motor housing until the switch actuator on the carriage is free from the switch.
 - b. Hold a steel scale across the machined face of the carriage slide and stand another scale on the machined face (near the head mounting holes) of the carriage.
 - c. Slowly move the carriage in towards the motor housing until the home switch "clicks". At this point, the vertical steel scale on the carriage face should indicate $2.050 \pm .020$ in. **IMPORTANT: THE SWITCH CHECK AND ADJUSTMENT MUST BE MADE ON THE BACKWARD "CLICK" OF THE HOME SWITCH AND NOT WHILE THE CARRIAGE IS MOVING FORWARD.**
 - d. If the switch adjustment is incorrect, bend the leaf actuator on the switch until the Step c. measurement is obtained.
8. Replace the read/write heads (Paragraph 5.3.3.2).
9. Check with a piece of blue plastic shim stock for .005-in. clearance between the transducer glass scale and the reticle. If the clearance is incorrect, loosen the transducer block mounting screws and reposition the block to obtain the correct clearance.

(continued on next page)

10. Replace the linear positioner (Paragraph 5.3.1.2).
11. Perform the servo system timing adjustment (Paragraph 5.3.2.6).
12. Check the read/write head alignment (Paragraph 5.3.3.3).

5.3.2.3 Carriage Bearing Assembly Removal

1. Remove the linear positioner (Paragraph 5.3.1.1).
2. Remove the carriage from the linear positioner (Paragraph 5.3.2.1).
3. Using a 3/8-in. nut driver, loosen the bearing shaft nut (Figure 5-6) one-half turn.
4. Hold the 3/8-in. bearing shaft nut and remove the retaining nut from the other end of the shaft.
5. Remove the bushing from the shaft and unscrew the bearing shaft.
6. Remove the bearing.

NOTE

Replace all four bearings at the same time.

5.3.2.4 Carriage Bearing Assembly Replacement

1. Insert the bearing into the bearing pocket. Ensure that the widest machined surface of the bearing (Figure 5-6 Insert) is towards the threaded hole in the pocket.
2. Insert the bearing shaft into the threaded pocket hole and through the center hole in the bearing.
3. Turn the 3/8-in. bearing shaft nut just a few turns to start the shaft threads into the pocket hole threads. Do not tighten the shaft at this time.
4. Insert the bushing on the other end of the shaft and replace the retaining nut.

NOTE

When performing Steps 5 and 6, do not allow the bearing assembly to touch the top or bottom of the carriage pocket.

5. Hold the 3/8-in. bearing shaft nut and tighten the retaining nut until the bushing moves the bearing close to the pocket top. Now tighten the 3/8-in. bearing shaft nut until the bearing moves close to the pocket bottom.
6. Continue alternate nut tightening as described in Step 5 until the bearing shaft and retaining nuts are secure.
7. Replace the carriage in the linear positioner (Paragraph 5.3.2.2).
8. Replace the linear positioner (Paragraph 5.3.1.2).
9. Check the read/write head alignment (Paragraph 5.3.3.3).

5.3.2.5 Transducer Block Removal and Replacement

1. Remove the linear positioner (Paragraph 5.3.1.1).
2. Remove the clamp attaching the position transducer leads to the carriage slide.
3. Remove the two screws attaching the transducer block to the carriage slide and carefully maneuver the transducer block out of the slide, ensuring that the block does not scratch the glass scale.
4. Install the new transducer block on the carriage slide with the previously removed hardware.

(continued on next page)

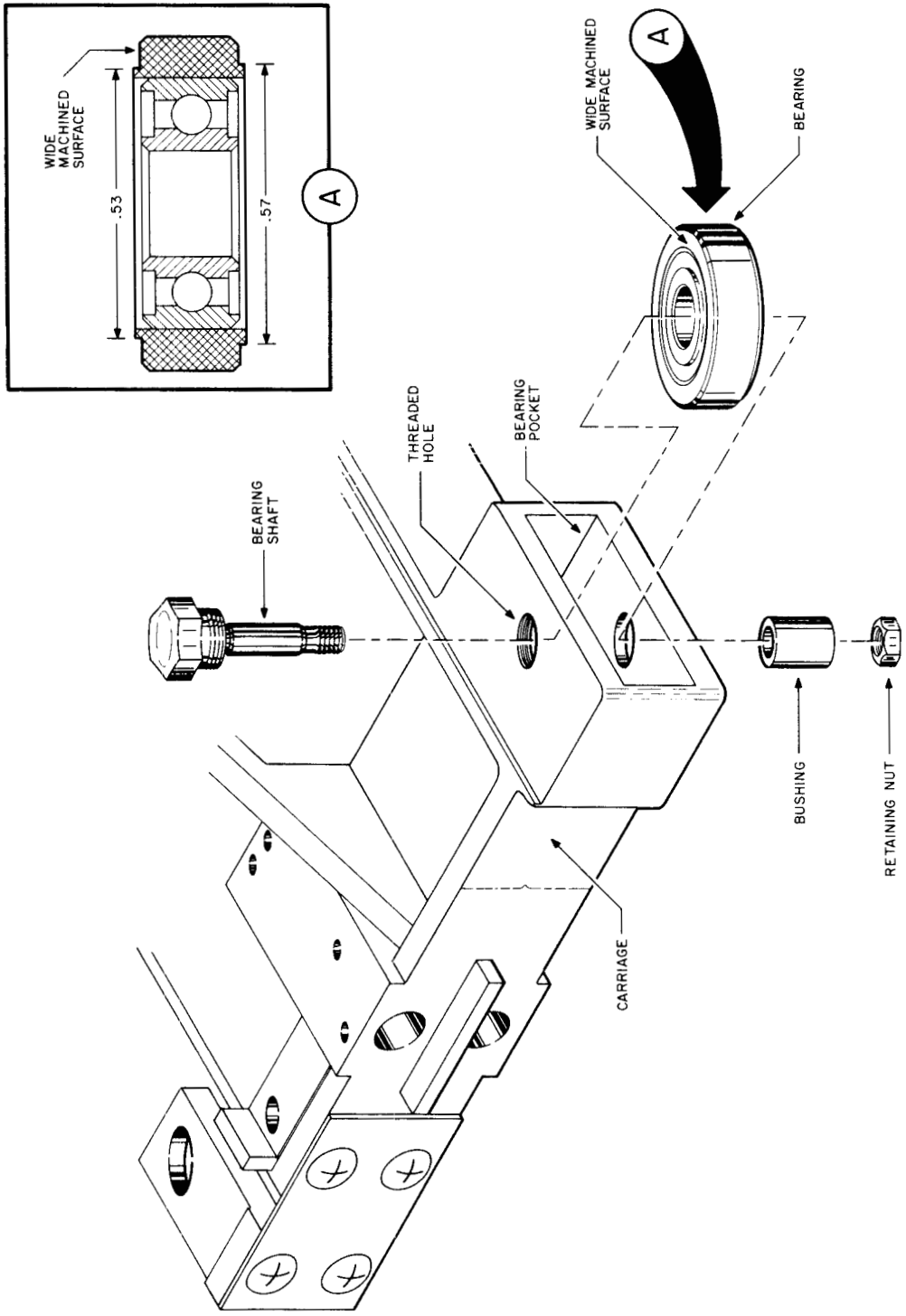

CP-0277

Figure 5-6 Carriage Bearing Assembly Removal

5. Replace the transducer leads in the clamp and attach the clamp to the carriage slide.
6. Check with a piece of blue plastic shim stock for .005-in. clearance between the transducer glass scale and the reticle. If the clearance is incorrect, loosen the transducer block mounting screws and reposition the block to obtain the correct clearance.
7. Replace the linear positioner (Paragraph 5.3.1.2) and perform the servo system timing adjustment (Paragraph 5.3.2.6).
8. Align the read/write heads (Paragraph 5.3.3.3).

5.3.2.6 Servo System Timing Adjustment

1. Place the computer program in HALT.
2. Remove both the top and bottom covers and install a cartridge on the spindle.
3. Remove the prefilter (Paragraph 5.2.5) to gain access to the servo adjustment potentiometers.
4. Set the oscilloscope controls as follows:
 - sweep time = 2 ms/div
 - vertical sensitivity = 2V/div
 - trigger = auto internal
5. Place the drive in the run mode, and monitor pin A5-S1 with the scope.
6. Turn off the positioner drive power (H604, S1-down) and, while moving the carriage by hand, adjust potentiometer CA (uppermost potentiometer) clockwise to obtain an approximate 10V peak-to-peak waveform (Figure 5-7A).
7. Continue moving the carriage and adjust potentiometer CO until the waveform is symmetrical (no offset) around the zero volt axis (Figure 5-7B).
8. Monitor pin A5-M1, move the carriage and adjust potentiometer SA clockwise to obtain an approximate 10V peak-to-peak waveform (Figure 5-7A).
9. Continue moving the carriage and adjust potentiometer SO until the waveform is symmetrical (no offset) around the zero volt axis (Figure 5-7B).
10. Monitor pin A5-J1, retract the carriage until the heads are unloaded, then adjust potentiometer LSA to obtain a +2.5 Vdc minimum level.
11. Move the carriage between cylinder 0 and cylinder 200, and adjust LSO for a 0 Vdc level.
12. Move the carriage fully forward to the inner position and check for a -2.5 Vdc minimum level. If necessary, adjust potentiometer LSA clockwise to obtain the correct voltage.
13. Repeat Steps 10 and 12, ensuring that neither the inner nor the unloaded positions go below the ± 2.5 Vdc minimum.
14. Move the carriage fully forward to the inner position, turn on the positioner drive power (H604, S1-up) and ensure that the heads restore (RTZ) to cylinder zero. If not, recheck Steps 5 through 13.
15. Change the scope trigger to external positive and the sweep time to 1 ms/div.
16. Perform an oscillating 0 to 2 cylinder seek as follows:
 - a. Determine which position the address select switch (S1) is in and connect a jumper from A8-T1 (ground) to one of the following corresponding pins:

$$S1 \left\{ \begin{array}{l} \text{pos 1} = \text{A8-J2} \\ \text{pos 2} = \text{A8-K2} \\ \text{pos 3} = \text{A8-L2} \\ \text{pos 4} = \text{A8-M2} \end{array} \right.$$

(continued on next page)

16. (cont)
- b. Connect a second jumper from A8-P2 to A8-D1.
 - c. Connect a third jumper from B8-H1 to B8-N2. The heads should now oscillate between cylinders 0 and 2.

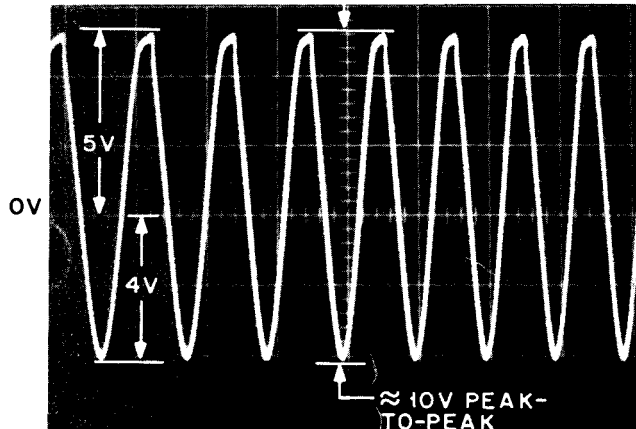

(A) Nonsymmetrical Sine-Cosine Amplitude Adjustment

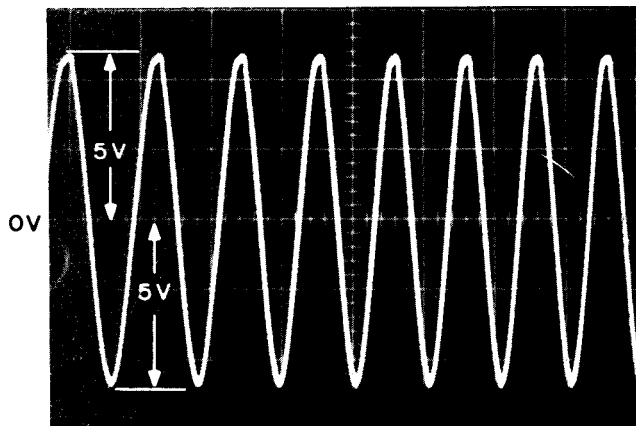

(B) Symmetrical Sine-Cosine Offset Adjustment

Figure 5-7 Sine-Cosine Adjustment Waveforms

17. Connect the scope trigger input to B5-J2.
18. Monitor pin A5-M1 and adjust potentiometer VA until the center cycle of the displayed sine wave (Figure 5-8) is 3.2 ms.
19. Change the scope sweep time to 5 ms/div, the vertical sensitivity to 50 mV/div, and perform an oscillating 0 to 64 cylinder seek as follows:
 - a. Remove the jumper connection at B8-N2 to stop the 0 to 2 oscillating seek.
 - b. Remove the jumper connection from A8-D1 and connect it to A8-E1.
 - c. Reconnect the B8-N2 jumper connection. The heads should now oscillate between cylinders 0 and 64.

(continued on next page)

20. Monitor pin A5-H1 and ensure that the displayed signal has a rise time of 14 ± 1 ms (Figure 5-9). If not, adjust the circular potentiometer on the H604 card to obtain the proper rise time.
21. Change the scope sweep time to 50 ms/div, the vertical sensitivity to 2V/div, and perform an oscillating 0 to 2 cylinder seek. (Step 16).
22. Adjust potentiometer VO until the signal position minimums are equal within $\pm 10\%$ of zero (Figure 5-10).
23. Remove all jumpers and restore the drive to normal operation.

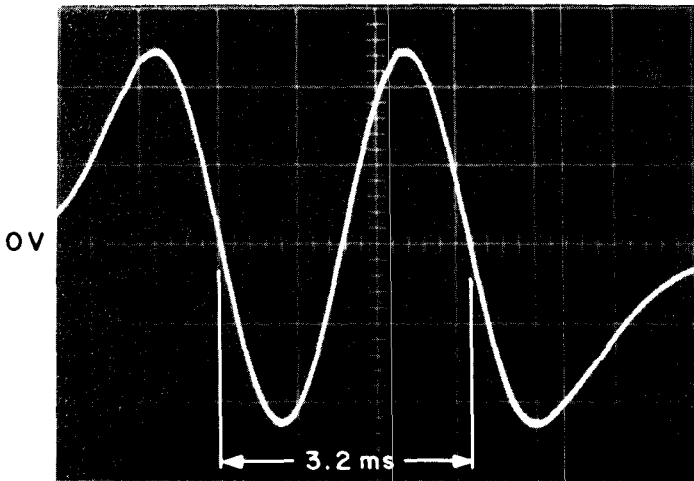

SWEEP TIME = 1 ms / DIV
 VERTICAL SENSITIVITY = 2V / DIV
 TRIGGER = EXTERNAL POSITIVE

Figure 5-8 2-Cylinder Seek Waveform

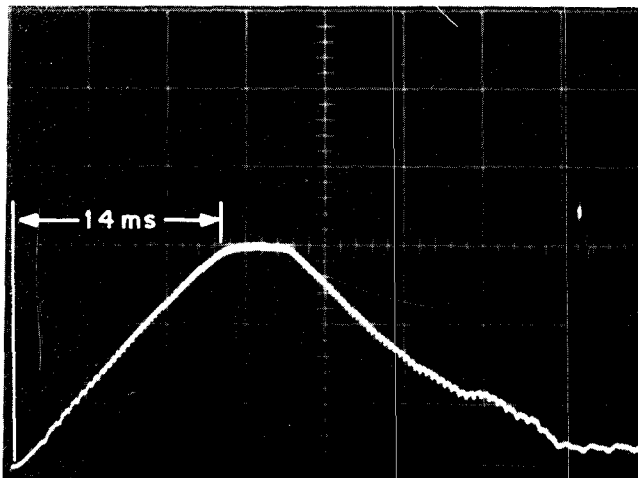

SWEEP TIME = 5 ms / DIV
 VERTICAL SENSITIVITY = 50mV / DIV
 TRIGGER = EXTERNAL POSITIVE

Figure 5-9 64-Cylinder Seek Waveform

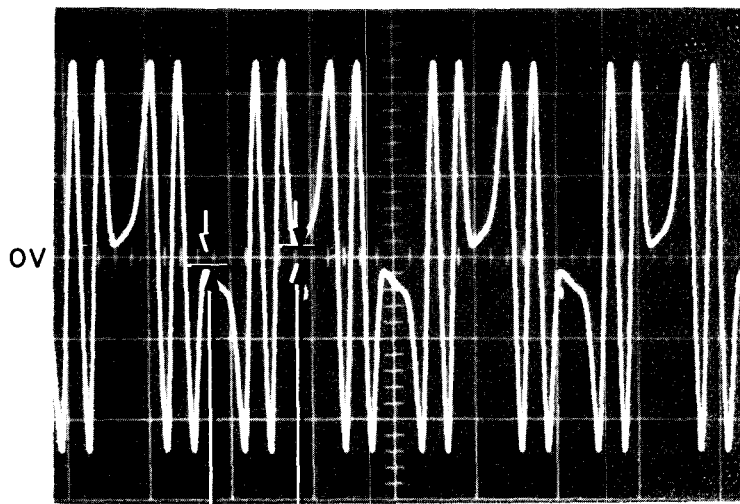

SWEEP TIME = 50ms/DIV
 VERTICAL SENSITIVITY = 2V/DIV
 TRIGGER = EXTERNAL POSITIVE

MINIMUMS EQUAL
 WITHIN $\pm 10\%$

Figure 5-10 Position Offset Adjustment Waveform

5.3.3 Read/Write Heads

5.3.3.1 Head Removal

1. Remove the disk cartridge from the drive.
2. Press the ON/OFF switch to OFF.
3. Open the rear door of the rack and disconnect the ac line cord.
4. Slide the drive out of the rack until it locks in the extended position.
5. Remove the top cover.
6. Disconnect the head connectors from the electronic module (Figure 5-5).
7. Unplug connector J5 from the power supply chassis (Figure 5-3).
8. Remove the two head clamp screws (Figure 5-11) and, with the carriage retracted to unload the heads, carefully remove the upper head.
9. Extend the carriage and remove the lower head.

5.3.3.2 Head Replacement

1. Extend the carriage and insert the lower head into the carriage.
2. Retract the carriage to the unloaded position and insert the upper head.
3. Replace the two head clamp screws (Figure 5-11).
4. Replace the read/write leads in the clamp on the carriage slide and connect the head leads to the electronic module. Refer to the decal on the electronic module for the correct lead connections.
5. Check the read/write head alignment (Paragraph 5.3.3.3).
6. Replace the top cover.
7. Slide the drive into the rack and connect the ac line cord.
8. Close the rear door and apply power.

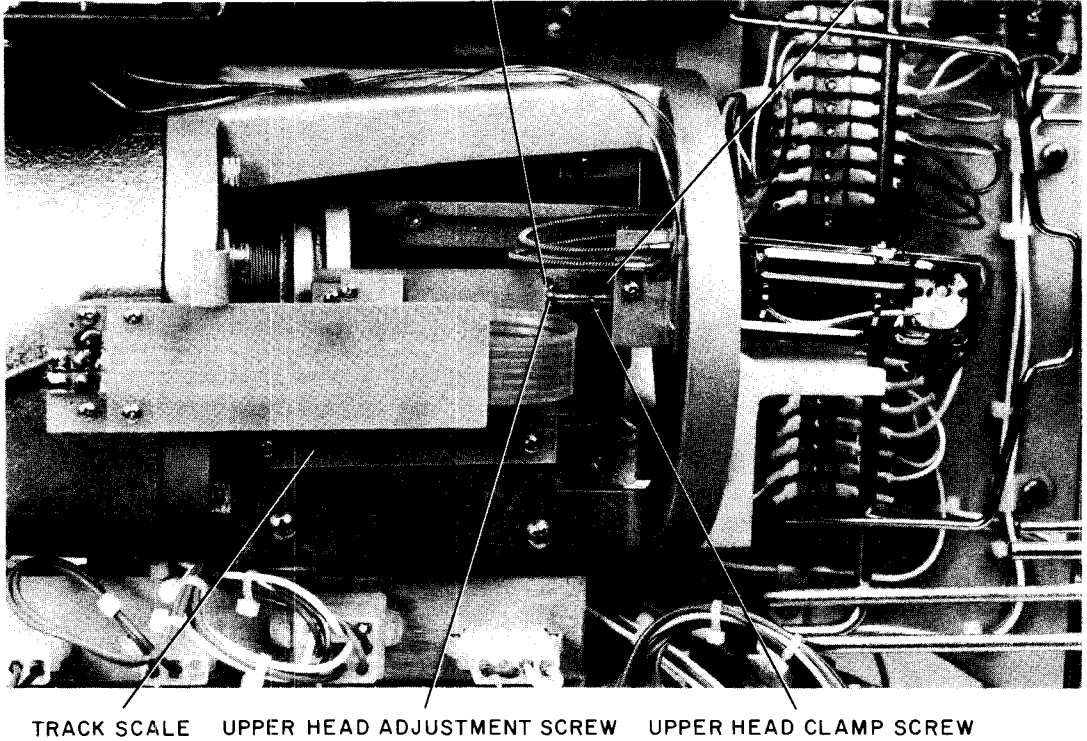

Figure 5-11 Read/Write Head Adjustments

5.3.3.3 Read/Write Head Alignment

1. Install a CE test cartridge on the spindle and operate the disk drive in the run mode for 15 min.

NOTE

The preceding step must be performed to allow the CE cartridge and the disk drive to obtain thermal stabilization.

2. Set the oscilloscope controls as follows:
 - sweep time = 5 ms/div
 - vertical sensitivity = 0.5V/div
 - trigger = external negative
3. Synchronize the scope on the leading edge of the INDEX L pulse at pin A2-R2 and monitor TP3 or TP4 of the G180 card.
4. Select either the lower or upper head by applying a logic high (lower head selected) or ground (upper head selected) to pin A8-M2 or A7-M2.
5. Turn off the positioner drive power (H604, S1-down) and move the carriage forward to the calibration track at cylinder 105. As the calibration track is approached, observe the scope display for a waveform as illustrated in Figure 5-12A. When the heads are at the calibration track, the waveform will appear as illustrated in Figure 5-12B. If the heads go beyond the calibration track, the waveform will appear as illustrated in Figure 5-12C.

6. Observe the positioner track scale and note the track indication when the correct calibration waveform (Figure 5-12B) is obtained.
7. If the correct waveform occurs and the track scale indicates less than 105, loosen the appropriate head clamp screw (Figure 5-11) and push the head in toward the positioner until the track scale indication is slightly greater than 105.
8. Lightly tighten the head clamp screw and ensure that the track indication is still slightly greater than 105 when the correct calibration waveform is displayed.
9. Position the heads at cylinder 105 and turn on the positioner drive power (H604, S1-up).
10. Turn the appropriate head adjusting screw (rear screw) clockwise until the signal minimums are equal within $\pm 10\%$ (Figure 5-12B).
11. Tighten the head clamp screw securely and recheck to ensure that the clamping action did not disturb the head adjustment.
12. Select the other head and repeat Steps 5 through 11.
13. Using the following jumper configuration, address cylinder 105 and confirm that the head alignment is correct:
 - a. Determine which position the address select switch (S1) is in and connect a jumper from A8-T1 (ground) to one of the following corresponding pins:

$$S1 \left\{ \begin{array}{l} \text{pos 1} = \text{A8-J2} \\ \text{pos 2} = \text{A8-K2} \\ \text{pos 3} = \text{A8-L2} \\ \text{pos 4} = \text{A8-M2} \end{array} \right.$$
 - b. Connect the following jumpers:
 - A8-P2 to A8-E1
 - A8-E1 to A8-J1
 - A8-J1 to A8-C1
 - A8-C1 to A8-K1
 - c. Connect a jumper from B8-H1 and momentarily contact B8-N2. Remove the B8-N2 contact as soon as the carriage starts to move.
14. When the carriage stops, monitor the scope and observe the track scale for the appropriate cylinder 105 indications.

5.3.3.4 Read/Write Data Separator (G180 Card) Adjustment

Adjustment of the data separator is not part of the normal maintenance and therefore is not recommended unless a G180 component that effects the data separator section has been replaced. If this occurs, set the width of the data window as follows:

1. Place the drive in the run mode and manually position the heads at any recorded cylinder. An all ZERO data recording is preferable; however, any recorded pattern is sufficient.
2. Set the oscilloscope controls as follows:
 - sweep time = 100 ns/div
 - vertical sensitivity = 1V/div
 - trigger = positive internal

A.
ONE TRACK PRIOR
TO CALIBRATION
TRACK

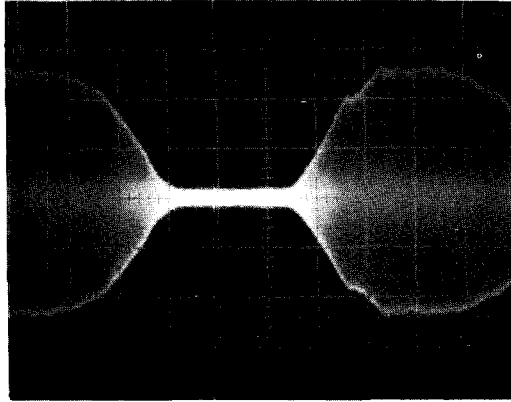

B.
CALIBRATION
TRACK

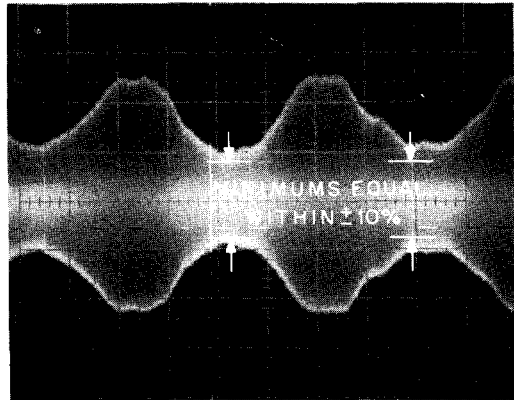

C.
ONE TRACK PAST
CALIBRATION
TRACK

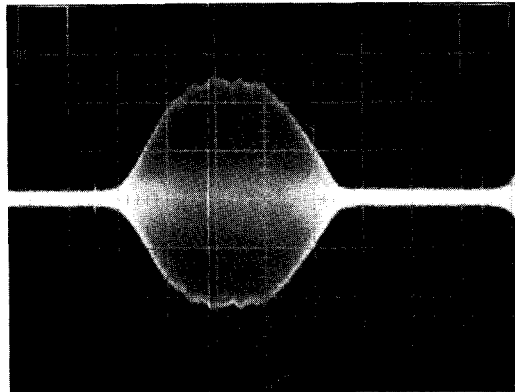

Figure 5-12 Read/Write Head Alignment Waveforms

3. Monitor TP1 on the G180 card. It should be possible to obtain solid scope synchronization at the sweep start. (Disregard the unsynchronized pulses that follow.)
4. Adjust potentiometer CL counterclockwise until no further increase in pulse width is observed.
5. Adjust potentiometer OL to obtain a 500-ns pulse width as measured from the start of the rise to the start of the fall.
6. Adjust potentiometer CL clockwise until the pulse width decreases to 420 ns as measured from the start of the rise to the start of the fall.

5.3.4 Spindle

5.3.4.1 Spindle Removal

1. Remove the disk cartridge from the drive.
2. Press the ON/OFF switch to OFF.
3. Open the rear door of the rack and disconnect the ac line cord.
4. Slide the drive out of the rack until it locks in the extended position.
5. Remove the top and bottom covers.
6. Remove the drive belt (Figure 5-13A) by first pushing the spindle motor mounting plate towards the spindle to relieve belt tension and then slipping the belt off the pulleys.

CAUTION

Do not remove the duckbill when performing Step 7, as this could allow read/write head damage when the cartridge receiver is raised.

7. Remove the tension springs from the cartridge receiver (Figure 5-13B) and raise the receiver as high as possible.
8. Remove the flexible magnet from the spindle armature to expose the access hole in the spindle plate.
9. Position the access hole over each of the spindle retaining screws and remove them.
10. Lift the spindle free from the drive baseplate.

5.3.4.2 Spindle Replacement

1. Raise the cartridge receiver as high as possible and install the spindle on the baseplate with the previously removed hardware.
2. Lower the cartridge receiver and attach the tension springs (Figure 5-13B).
3. Push the spindle motor mounting plate (Figure 5-13A) towards the spindle and slip the drive belt around the pulleys.
4. Connect the ac line cord and check the read/write head alignment (Paragraph 5.3.3.3).
5. Replace the top and bottom covers.
6. Slide the drive into the rack and close the rear door.

5.3.4.3 Sector Pulse Timing Adjustment

Before attempting the following measurements, check the oscilloscope probe compensation to ensure that the probe calibration is correct.

1. Install a CE test cartridge on the spindle and ensure that the read/write heads are aligned properly (Paragraph 5.3.3.3).
2. Set the oscilloscope controls as follows:
 - sweep time = 20 μ s/div
 - vertical sensitivity = 0.5V/div
 - trigger = external negative
3. Synchronize the scope on the leading edge of the INDEX L pulse at pin A2-R2 and monitor TP3 or TP4 of the G180 card.

(continued on next page)

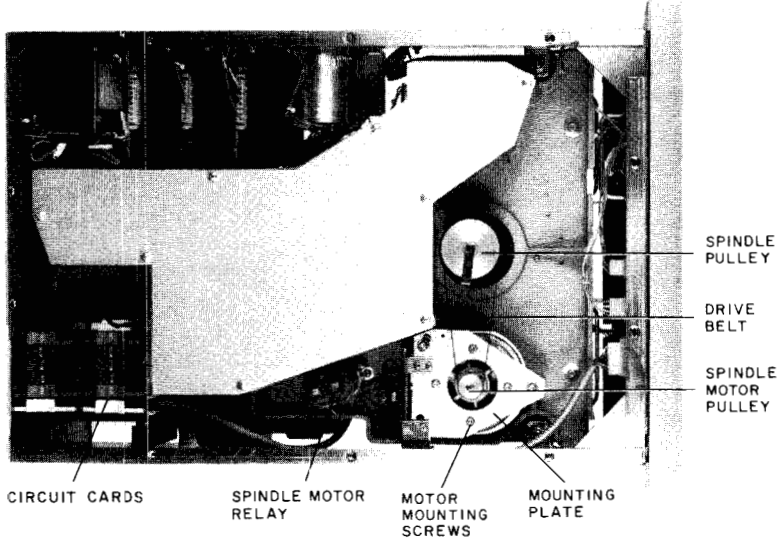

(A) Drive Belt

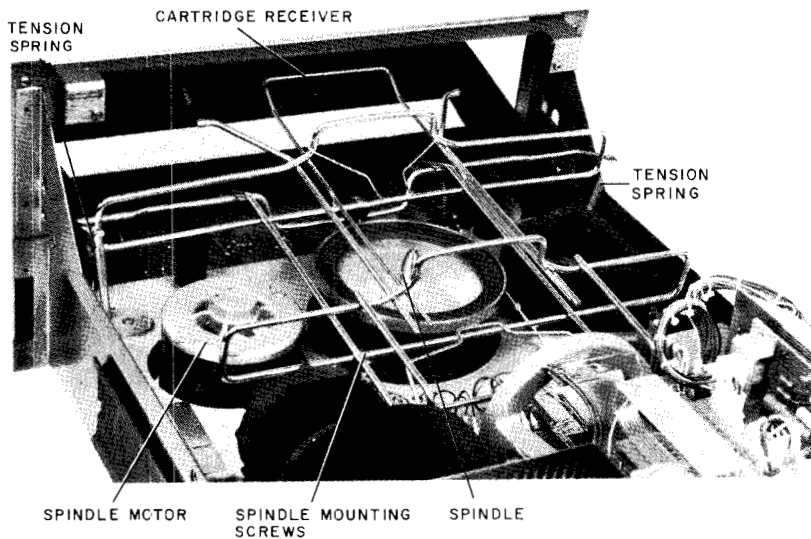

(B) Spindle

Figure 5-13 Spindle Replacement

4. Select either the lower or upper head by applying a logic high (lower head selected) or ground (upper head selected) to pin A8-M2 or A7-M2.
5. Position the heads at cylinder 100 and observe the scope display for a single pulse followed by a burst.
6. Expand the sweep time and adjust R6 on the M7700 card until the single pulse occurs 30 μ s after the start of the sweep (pulse delay).
7. Select the other head and observe the pulse delay. Readjust R6 as required until the average pulse delay for both upper and lower heads is 30 μ s.

(continued on next page)

8. If the correct pulse delay cannot be achieved, loosen the sector transducer mounting screws and move the transducer slightly to the right to decrease, or slightly to the left to increase the pulse delay time.
9. Tighten the sector transducer mounting screws and readjust R6 if necessary.

5.3.5 Spindle Drive Motor

5.3.5.1 Motor Removal

1. Remove the disk cartridge from the drive.
2. Press the ON/OFF switch to OFF.
3. Open the rear door of the rack and disconnect the ac line cord.
4. Slide the drive out of the rack until it locks in the extended position.
5. Remove the top and bottom covers.
6. Disconnect the spindle motor leads from TB4 (Figure 5-15) and from the spindle motor relay (Figure 5-13A).
7. Remove the drive belt by first pushing the spindle motor mounting plate towards the spindle to relieve belt tension and then slipping the belt off the pulleys.
8. Remove the four screws attaching the motor to the mounting plate and remove the motor through the top of the baseplate.

5.3.5.2 Motor Replacement

1. Insert the spindle motor through the top of the baseplate (Figure 5-13B) and attach the motor to the mounting plate with the previously removed hardware.
2. Push the spindle motor mounting plate (Figure 5-13A) towards the spindle and slip the drive belt around the pulleys.
3. Connect the spindle motor leads to TB4 (Figure 5-15) and to the spindle motor relay (Figure 5-13A).

NOTE

Refer to the chassis wiring drawing for TB4 and the spindle motor relay connection color code.

4. Replace the top and bottom covers.
5. Slide the drive into the rack and connect the ac line cord.
6. Close the rear door and apply power.

5.3.6 Drive Belt Removal and Replacement

1. Remove the disk cartridge from the drive.
2. Press the ON/OFF switch to OFF.
3. Open the rear door of the rack and disconnect the ac line cord.
4. Slide the drive out of the rack until it locks in the extended position.
5. Remove the bottom cover.
6. Push the spindle motor mounting plate (Figure 5-13A) towards the spindle to relieve belt tension and slip the belt off the pulleys.
7. Clean the spindle and drive motor pulleys with a clean cloth moistened with 91% isopropyl alcohol.

(continued on next page)

8. Install a new drive belt by pushing the spindle motor mounting plate towards the spindle and slipping the drive belt around the pulleys.
9. Replace the bottom cover.
10. Slide the drive into the rack and connect the ac line cord.
11. Close the rear door and apply power.

5.3.7 Blower Motor

5.3.7.1 Blower Removal

1. Remove the disk cartridge from the drive.
2. Press the ON/OFF switch to OFF.
3. Open the rear door of the rack and disconnect the ac line cord.
4. Slide the drive out of the rack until it locks in the extended position.
5. Remove the top and bottom covers.
6. Remove the prefilter (Figure 5-1) and disconnect the head connectors (Figure 5-3) from the electronic module.
7. Remove all circuit cards from the electronic module.
8. Remove the three screws attaching the blower collar (Figure 5-14) to the electronic module and pull the collar through the prefilter opening.
9. Disconnect the blower leads from TB4 (Figure 5-15).
10. Remove the four blower mounting screws and remove the blower and shroud from the baseplate.

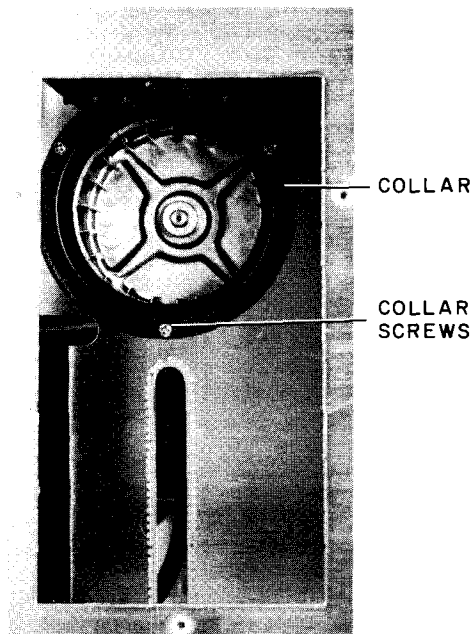

Figure 5-14 Blower Collar Removal

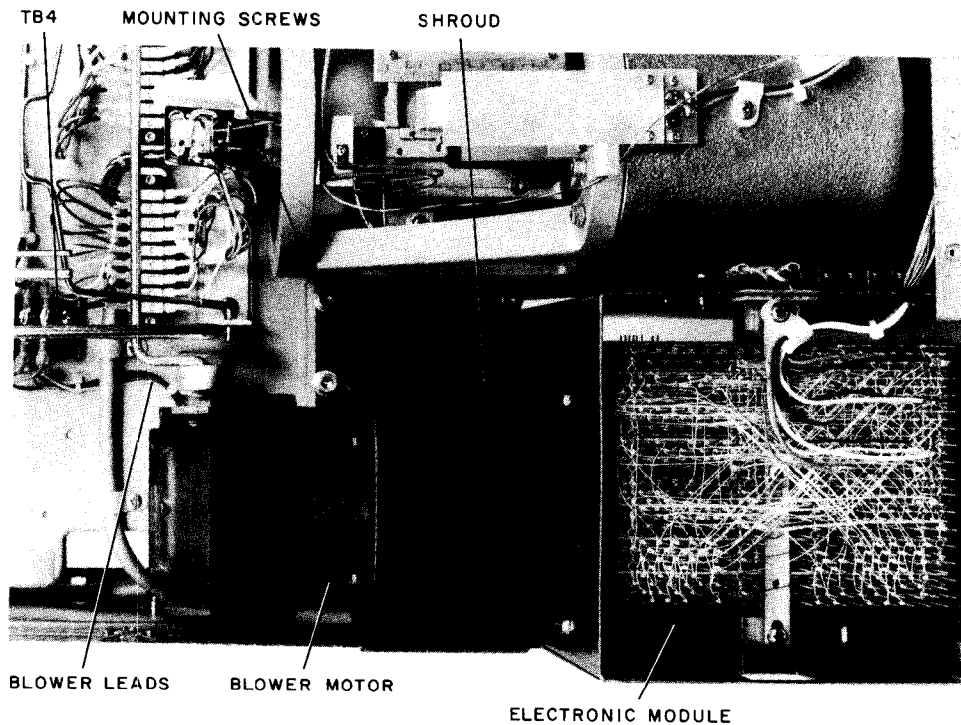

Figure 5-15 Blower Motor Removal

5.3.7.2 Blower Replacement

1. Secure the blower and shroud to the baseplate (Figure 5-15) with the previously removed hardware.
2. Connect the blower leads to TB4.
3. Insert the collar (Figure 5-14) through the prefilter opening and attach it with the previously removed hardware.
4. Replace the circuit cards in the electronic module.
5. Replace the prefilter (Paragraph 5.2.5).
6. Replace the top and bottom covers.
7. Slide the drive into the rack and connect the ac line cord.
8. Close the rear door and apply power.

5.4 SPARE PARTS LIST

For ease of parts identification and replacement, Table 5-3 lists and describes the recommended spare parts.

Table 5-3
Spare Parts List

Part Number	Description
D-UA-RK05-0-0	RK05 DISK DRIVE
A-PS-1210812	Belt, Spindle Drive
A-PS-1210807-1-0	Blower, Centrifugal
1009397	Capacitor, 5 MFD @ 370V (with clamp)
1010646	Capacitor, .015 MFD @ 50V, 2% polycarb
M983	Card, Cable Connector
M7701	Card, Control and Interlock
G938	Card, Head Position Servo Preamplifier
H604	Card, Head Position Servo Power Amplifier
M7700	Card, Index and Sector
5409547-0-0	Card, Motor Relay
G180	Card, Read/Write
M7702	Card, Track Address and Difference
A-PS-3010250-01	Cartridge, 12 Sector H.D.
19-10282	DIP, 8 Pin Mini-LM301
19-10298	DIP, 8 Pin Mini-72741
A-PS-1210803-0-0	Filter, Absolute Air
C-MD-7409254-0-0	Gasket, Airduct
A-PS-3010863-2B	Head, Lower Read/Write
A-PS-3010863-1B	Head, Upper Read/Write
1209169	Lamp, Indicator
A-PS-12110808-0-0	Motor, Spindle Induction
C-MD-7409253-0-0	Pad, Filter
5409698-0-1	Panel, Control
B-MD-7409418-2-0	Pulley, 50 Hz Motor
B-MD-7409418-1-0	Pulley, 60 Hz Motor
1210683	Relay, 10A General Purpose
1210800	Relay, Motor
C-SC-1210616-0-0	Spindle
1210839	Switch
1205375	Switch, Rocker
1205941	Switch, Rocker
1210043	Switch, 6 Pos. Rotary
A-PS-3010642-0-0	Transducer, Sector
15-09618	Transistor, FET-2N5245
1510171	Transistor, Medium Power – DEC44C3
15-10421	Transistor, Medium Power – D44C8
15-10414	Transistor, Medium Power – D45C6
15-03063	Transistor, Power – 2N3715
15-09581	Transistor, Power – 2N3791
7008702-0-0	LINEAR POSITIONER
1210838-1	Actuator, Switch (Licon)
C-IA-7409386-0-0	Bearing Assembly
D-SC-1210744-0-0	Duck Bill

(continued on next page)

Part Number	Description
17-00017	Flex Strip
A-PS-1210811-0-0	Set Screw
B-MD-7409368-0-0	Strap, Carriage Shipping
1210838-2	Switch, 16-404 (Licon)
A-PS-3010638-0-0	Transducer, Linear Position
A-PS-3010638-1-0	Block, Transducer
A-PS-3010638-2-0	Scale, Transducer Glass
H743-0-0	POWER SUPPLY
9008219	Amp 250 Tab 42117-1
1210641	Battery, 4 Cell
1010510	Capacitor, 6000 MFD @ 50V
1205293	Circuit Breaker, 5A (Wood)
9007917	Connector, Solderless
9007587	Faston, Tab
A-PS-1010585-0-0	Filter, Line
1210781	Indicator, Elapsed Time
1110051	Rectifier, MDA990-3
E-IA-5409484-0-0	Regulator, 15V
E-IA-5409503-0-0	Regulator, +5V
9007193	Terminal, No. 3000-541B (Arcless)
1610511	Transformer

5.5 TROUBLESHOOTING

(to be supplied)

READER'S COMMENTS

Your comments and suggestions will help us in our continuous effort to improve the quality and usefulness of our publications.

What is your general reaction to this manual? In your judgement is it complete, accurate, well organized, well written, etc.? Is it easy to use? _____

What features are most useful? _____

What faults do you find with the manual? _____

Does this manual satisfy the need you think it was intended to satisfy? _____

Does it satisfy *your* needs? _____ Why? _____

Would you please indicate any factual errors you have found. _____

Please describe your position. _____

Name _____ Organization _____

Street _____ Department _____

City _____ State _____ Zip or Country _____

**Digital Equipment Corporation
Maynard, Massachusetts**

