

**RK05/RK05J/RK05F
disk drive
maintenance manual**

EK-RK5JF-MM-001

Copyright © 1976 by Digital Equipment Corporation

The material in this manual is for informational purposes and is subject to change without notice.

Digital Equipment Corporation assumes no responsibility for any errors which may appear in this manual.

Printed in U.S.A.

This document was set on DIGITAL's DECset-8000 computerized typesetting system.

The following are trademarks of Digital Equipment Corporation, Maynard, Massachusetts:

DEC	DECtape	PDP
DECCOMM	DECUS	RSTS
DECsystem-10	DIGITAL	TYPESET-8
DECSYSTEM-20	MASSBUS	TYPESET-11
		UNIBUS

CONTENTS

		Page
CHAPTER 1	GENERAL INFORMATION	
1.1	INTRODUCTION	1-1
1.2	WARRANTY	1-1
1.3	SPECIFICATIONS	1-1
1.4	50/60 Hz POWER OPTION	1-4
1.5	MAJOR ASSEMBLIES AND SYSTEMS	1-4
1.5.1	Controls and Indicators	1-4
1.5.2	Spindle and Drive	1-4
1.5.3	Linear Positioner	1-10
1.5.4	Cartridge-Handling System	1-10
1.5.5	Logic Assembly	1-13
1.5.6	Air System	1-13
1.5.7	Power Supply	1-13
1.5.8	Read/Write Heads	1-13
CHAPTER 2	INSTALLATION	
2.1	UNPACKING AND INSPECTION	2-1
2.2	MECHANICAL INSTALLATION AND CHECKOUT	2-3
2.3	CARTRIDGE-HANDLING PRACTICES AND PRECAUTIONS	2-7
2.4	CARTRIDGE PACKING AND SHIPPING	2-8
2.5	NORMAL OPERATING PROCEDURES	2-8
2.5.1	RK05 and RK05-J Cartridge Loading	2-8
2.5.2	RK05 and RK05-J Cartridge Unloading	2-8
2.5.3	RK05-F Cartridge Installation	2-9
2.5.4	RK05-F Cartridge Removal	2-10
CHAPTER 3	INTERFACE	
3.1	GENERAL	3-1
3.2	INPUT INTERFACE LINES	3-1
3.2.1	RK11-D	3-1
3.2.2	Select (4 Lines)	3-1
3.2.3	Cylinder Address (8 Lines)	3-3
3.2.4	Strobe	3-3
3.2.5	Head Select	3-3
3.2.6	Write Protect Set	3-3
3.2.7	Write Data and Clock	3-3
3.2.8	Write Gate	3-3
3.2.9	Restore (RTZ)	3-3
3.2.10	Read Gate	3-4
3.3	OUTPUT INTERFACE LINES	3-4
3.3.1	File Ready (Drive Ready)	3-4
3.3.2	Read, Write, or Seek Ready/On Cylinder	3-4
3.3.3	Address Accepted	3-4
3.3.4	Address Invalid (Logic Address Interlock)	3-4

CONTENTS (Cont)

		Page
3.3.5	Seek Incomplete	3-4
3.3.6	Write Protect Status	3-4
3.3.7	Write Check	3-4
3.3.8	Read Data	3-5
3.3.9	Read Clock	3-5
3.3.10	Sector Address (4 Lines)	3-5
3.3.11	Sector Pulse	3-5
3.3.12	Index Pulse	3-5
3.3.13	AC LOW	3-5
3.3.14	DC LOW	3-5
3.3.15	High Density/RK05 L	3-5
CHAPTER 4	THEORY OF OPERATION	
4.1	FUNCTIONAL DESCRIPTION	4-1
4.1.1	Start	4-1
4.1.2	Stop	4-1
4.1.3	Track Addressing and Head Positioning	4-5
4.1.4	Recording Technique	4-5
4.2	LOGICAL DESCRIPTION	4-5
4.2.1	Power ON/OFF Sequence	4-5
4.2.2	Start	4-5
4.2.3	Stop	4-11
4.2.3.1	Normal Stop	4-11
4.2.3.2	Low Speed Stop	4-12
4.2.3.3	AC Low Stop	4-12
4.2.3.4	DC Low Stop	4-12
4.2.4	Disk Drive Addressing	4-12
4.2.4.1	RK11-D Address Selection	4-12
4.2.4.2	RK11-C or RK8/E Address Selection	4-12
4.2.5	Seek	4-13
4.2.5.1	Load Heads Seek	4-13
4.2.5.2	Forward Seek	4-13
4.2.5.3	Reverse Seek	4-15
4.2.5.4	Return-to-Zero (Restore) Seek	4-15
4.2.6	Sector/Index Pulse Generation	4-16
4.3	CARRIAGE POSITIONING	4-16
4.3.1	Positioner Servo Description	4-16
4.3.1.1	Velocity Mode	4-18
4.3.1.2	Detent Mode	4-19
4.3.2	Servo Circuit Description	4-19
4.3.2.1	Linear Positioner Transducer	4-19
4.3.2.2	Velocity Function Generator	4-19
4.3.2.3	Velocity Synthesizer	4-19

CONTENTS (Cont)

		Page
4.4	READ/WRITE	4-22
4.4.1	Read Operation	4-22
4.4.2	Write Operation	4-26
4.5	FAULT DETECTION	4-27
4.5.1	Current Fault	4-27
4.5.2	Positioner Lamp Fault	4-27
4.6	POWER SUPPLY DESCRIPTION	4-27
CHAPTER 5	MAINTENANCE	
5.1	CUSTOMER EQUIPMENT CARE	5-1
5.1.1	Weekly Care	5-1
5.1.2	Monthly Care	5-1
5.2	PREVENTIVE MAINTENANCE	5-1
5.3	CORRECTIVE MAINTENANCE	5-3
5.3.1	Linear Positioner	5-3
5.3.1.1	Positioner Removal	5-3
5.3.1.2	Positioner Replacement	5-4
5.3.2	Carriage	5-6
5.3.2.1	Carriage Removal	5-6
5.3.2.2	Carriage Replacement	5-7
5.3.2.3	Carriage Bearing Assembly Removal	5-8
5.3.2.4	Carriage Bearing Assembly Replacement	5-9
5.3.2.5	Transducer Block Removal and Replacement	5-9
5.3.2.6	Transducer Bulb Replacement	5-10
5.3.3	Read/Write Heads	5-10
5.3.3.1	Carriage Revisions	5-10
5.3.3.2	Head Removal	5-10
5.3.3.3	Head Replacement	5-10
5.3.4	Spindle	5-13
5.3.4.1	Spindle Removal	5-13
5.3.4.2	Spindle Replacement	5-14
5.3.4.3	Spindle Ground (Carbon Brush) Removal and Replacement	5-15
5.3.5	Spindle Drive Motor	5-15
5.3.5.1	Motor Removal	5-15
5.3.5.2	Motor Replacement	5-16
5.3.5.3	Drive Belt Removal and Replacement	5-17
5.3.6	Blower Motor	5-17
5.3.6.1	Blower Removal	5-17
5.3.6.2	Blower Replacement	5-19
5.3.7	Power Supply Removal	5-19
5.3.8	Cartridge Cleaning	5-19
5.3.8.1	Cartridge Cleaning Procedure	5-19
5.3.8.2	Adverse Disk Conditions	5-21
5.4	ALIGNMENT, CHECKS, AND ADJUSTMENTS	5-22
5.4.1	Alignment Cartridges	5-22

CONTENTS (Cont)

		Page
5.4.1.1	RK05K-AC Alignment Cartridge	5-22
5.4.1.2	2315 CE Test Cartridge Shim Installation	5-23
5.4.2	Servo System Timing Checks and Adjustments	5-25
5.4.2.1	Dynamic Off-Line Checks and Adjustments	5-26
5.4.2.2	Static Tests and Adjustments	5-34
5.4.3	Read/Write Data Separator (G180 Card) Adjustment	5-35
5.4.4	Read/Write Head Check and Alignment	5-36
5.4.4.1	RK05K-AC Alignment Cartridge	5-36
5.4.4.2	2315 CE Pack	5-44
5.4.5	Index/Sector Timing Adjustment	5-50
5.4.5.1	RK05K-AC Alignment Cartridge	5-50
5.4.5.2	2315 CE Pack	5-52
5.4.6	Cartridge Receiver Alignment	5-55
5.5	SPARE PARTS	5-59
5.6	TROUBLESHOOTING	5-60
5.6.1	Power Supply	5-60
5.6.2	Controls and Indicators	5-62
5.6.3	Mechanical Checks	5-62
5.6.4	Electronic Checks	5-64

ILLUSTRATIONS

Figure No.	Title	Page
1-1	Location of Major Assemblies and Systems (RK05)	1-5
1-2	Location of Major Assemblies and Systems (RK05-J)	1-6
1-3	Location of Major Assemblies and Systems (RK05-F)	1-7
1-4	Controls and Indicators	1-8
1-5	Spindle and Drive System	1-10
1-6	Linear Positioner (RK05/RK05-J/RK05-F)	1-11
1-7	RK05 Cartridge-Handling System	1-12
1-8	RK05-J Cartridge-Handling System	1-14
1-9	RK05-F Cartridge-Handling System	1-15
1-10	Air System	1-16
1-11	Head Loading	1-16
1-12	Relationship of Disk Head, Disk, and Contaminants	1-17
2-1	Shipping Bracket and Shipping Strap Locations	2-2
2-2	RK11-C or RK11-D Interface Cable Installation	2-3
2-3	Chassis Slide Mounting	2-4
2-4	RK8/E Interface Cable Installation	2-6
2-5	RK05-F Cartridge	2-9
2-6	RK05-F Cartridge Installed	2-10
3-1	Controller/RK05 Disk Drive Interface Lines and Pin Assignments	3-2
4-1	Functional Block Diagram	4-2

ILLUSTRATIONS (Cont)

Figure No.	Title	Page
4-2	Start Flowchart	4-3
4-3	Stop Flowchart	4-4
4-4	Seek Flowchart	4-6
4-5	Return-to-Zero (Restore) Flowchart	4-7
4-6	Read/Write Head	4-8
4-7	Simplified Read/Write Head Circuit	4-8
4-8	Double Frequency Pulse Relationship	4-9
4-9	Control and Interlock Block Diagram	4-10
4-10	Sector/Index Timing	4-17
4-11	Servo System Block Diagram	4-18
4-12	Linear Positioner Transducer	4-20
4-13	Simplified Positioner Servo Logic	4-21
4-14	Velocity Profile (RK05/RK05-J)	4-22
4-15	Simplified Data Separator Circuit	4-23
4-16	Read Waveforms	4-24
4-17	Internal Power Supply Connections	4-28
5-1	Prefilter	5-2
5-2	Absolute Filter Removal	5-5
5-3	Top View of RK05 with Cover Removed	5-6
5-4	Carriage Bearing Assembly Removal	5-8
5-5	Read/Write Head Carriage Revision	5-11
5-6	Read/Write Head Replacement	5-12
5-7	Spindle Replacement	5-14
5-8	Drive Belt	5-15
5-9	Carbon Brush Replacement	5-16
5-10	Blower Motor Removal	5-18
5-11	How to Read a Vernier	5-22
5-12	Negligible Runout	5-24
5-13	Considerable Runout	5-24
5-14	CE Test Cartridge Shim Installation	5-25
5-15	Sine Amplitude/Offset and Velocity Offset Waveform	5-29
5-16	Cosine Amplitude/Offset Waveform	5-30
5-17	Velocity Amplitude Waveform	5-31
5-18	Acceleration Waveform	5-32
5-19	Full Stroke Waveform	5-33
5-20	Full Stroke Position Waveform	5-33
5-21	Outer Limit Waveform	5-34
5-22	RK05K-AC Head Alignment Waveforms	5-37
5-23	Read/Write Head Adjustments	5-41
5-24	2315 CE Pack Head Alignment Waveforms	5-45
5-25	Index/Sector Waveform	5-52
5-26	Cartridge-to-Receiver Clearance	5-56
5-27	Cartridge Receiver Clearances	5-57
5-28	Cartridge Receiver, Newer Models (RK05/RK05-J)	5-58
5-29	Cartridge Receiver, RK05-F	5-58

ILLUSTRATIONS (Cont)

Figure No.	Title	Page
5-30	Troubleshooting Flowchart	5-61
5-31	Door Locking Bar Location	5-63
5-32	Cartridge Seating Elements	5-63

TABLES

Table No.	Title	Page
1-1	Performance Specifications	1-2
1-2	Controls and Indicators for the RK05, RK05-J, and RK05-F	1-8
5-1	Recommended Tools and Test Equipment	5-3
5-2	Positioner Transducer Wire Configuration	5-4
5-3	Servo System Checks	5-26
5-4	Servo System Adjustments	5-30

CHAPTER 1

GENERAL INFORMATION

1.1 INTRODUCTION

The RK05, RK05-J, and RK05-F Disk Drives, which comprise the RK05 family of disk drives, are self-contained, random-access, data storage devices that are especially well suited for small or medium-sized computer systems, data acquisition systems, terminals, and other storage applications. Operational power for all of these devices is provided by power supplies located within the drive cabinets. Drives in the RK05 family are available in four models, each of which operates on a different power line.

These compact, lightweight drives use high-density, single-disk, 12- or 16-sector cartridges as the storage medium. The cartridge used in the RK05 and RK05-J Disk Drives is removable; the cartridge used in the RK05-F is fixed. Two movable heads, one flying above the rotating disk surface and one below, can read or record up to 406 data tracks in the RK05 and RK05-J models, and up to 812 data tracks in the RK05-F. In all drives, the disks revolve at 1500 rpm. The double-frequency, nonreturn-to-zero (NRZ) recording method used in these drives can store up to 25 million bits of on-line data in the RK05 and RK05-J, and up to 50 million bits in the RK05-F. Data formatting is governed entirely by the operating system.

With the address select logic contained in each drive, up to eight RK05 or RK05-J Disk Drives (depending on the type of system) can be "daisy-chained" and operated from a single controller bus. The RK05-F is addressed as two logical RK05-Js. Combinations of RK05, RK05-J, and RK05-F Disk Drives are possible, as long as the RK05-F drives are addressed as "Drives 0/1," "Drives 2/3," "Drives 4/5," or "Drives 6/7." No other addressing number pairs may be used to address an RK05-F.

1.2 WARRANTY

"Removable media involve use, handling and maintenance which are beyond DEC's direct control. DEC disclaims responsibility for performance of the Equipment when operated with media not meeting DEC specifications or with media not maintained in accordance with procedures approved by DEC. DEC shall not be liable for damages to the Equipment or to media resulting from such operation."

1.3 SPECIFICATIONS

Table 1-1 lists the performance specifications for the RK05 family of disk drives. Where applicable, distinctions are made between RK05, RK05-J, and RK05-F Disk Drives and 12- and 16-sector cartridges.

Table 1-1 Performance Specifications

Characteristic	Specification
Storage Medium	
Type	Single disk magnetic cartridge (RK05, RK05J - removable; RK05F - nonremovable)
Disk Diameter	14 inches
Magnetic Heads	
Number	Two
Recording Density and Format	
Density	2200 bpi max.
Tracks (RK05 and RK05J)	406 (200 plus 3 spares on each side of the disk)
Tracks (RK05F)	812 (400 plus 6 spares on each side of the disk)
Cylinders (RK05 and RK05J)	203 (two tracks each)
Cylinders (RK05F)	406 (two tracks each)
Sectors (records)(RK05 and RK05J)	4872 (12 per revolution)
	6496 (16 per revolution)
Sectors (records)(RK05F)	9744 (12 per revolution)
	12996 (16 per revolution)
Bit Capacities (unformatted)*	
Per Disk (RK05 and RK05J)	25 million
Per Disk (RK05F)	50 million
Per Inch	2040 (max. at inner track)
Per Cylinder	115,200
Per Track	57,600
Per Sector	4,800/3,844
Access Times	
Disk Rotation	1500 ± 30 rpm
Average Latency	20 ms (half rotation) } RK05/RK05J
Head Positioning	-for adjacent tracks 0 ms
(including settling time)	-average 50 ms
	-for 200 track movement 85 ms
Bit Transfer*	
Transfer Code	Double frequency, NRZ recording
Transfer Rate	1.44M bits per seconds
Electrical Requirements	
Voltage	115/230 Vac @ 50/60 Hz ± .05 Hz
Power	250 VA
Starting Current	Power only: 1.8 A Start spindle: 10 A (for 2 seconds)

*Some RK11-D systems record at 1.54 bits/second which increases the bit density and capacity accordingly.

Table 1-1 Performance Specifications (Cont)

Characteristic	Specification
Model Designation	
RK05-AA, RK05J-AA, RK05F-AA, RK05F-FA	95 - 130 Vac @ 60 ± 0.5 Hz
RK05-AB, RK05J-AB, RK05F-AB, RK05F-FB	190 - 260 Vac @ 60 ± 0.5 Hz
RK05-BA, RK05J-BA, RK05F-AC, RK05F-FC	95 - 130 Vac @ 50 ± 0.5 Hz
RK05-BB, RK05J-BB, RK05F-AD, RK05F-FD	190 - 260 Vac @ 50 ± 0.5 Hz
Environment	
Ambient Temperature	50° - 110° F (10° - 43° C nominal)
Relative Humidity	8% - 80% (no condensation)
Barometric Pressure	10,000 ft (3,000 meters) max.
Temperature, Change Rate	10° F (6° C) per hr
Temperature, Interchangeable Range (RK05, RK05J)	30° F (17° C)
Dimensions and Weight	
Width	19 inches (48 cm)
Depth	26-1/2 inches (67 cm)
Height	10-1/2 inches (27 cm)
Weight	110 lb (50 kg)

1.4 50/60 Hz POWER OPTION

Disk drives in the RK05 family are available in the following four power model

RK05-AA RK05-J-AA RK05-F-AA	} 95 - 130 Vac @ 60 Hz
RK05-AB RK05-J-AB RK05-F-AB	} 190 - 260 Vac @ 60 Hz
RK05-BA RK05-J-BA RK05-F-BA	} 95 - 130 Vac @ 50 Hz
RK05-BB RK05-J-BB RK05-F-BB	} 190 - 260 Vac @ 50 Hz

Changing from 50 to 60 Hz operation requires a different spindle drive pulley, and the motor must be moved as described in Paragraph 5.3.5 of this manual. Changing from 115 V to 230 V operation requires that the power connector (P2) be reconfigured (Paragraph 4.6).

1.5 MAJOR ASSEMBLIES AND SYSTEMS

The drives in the RK05 family are composed of the following major assemblies and systems:

- Controls and Indicators
- Spindle and Drive System
- Linear Positioner
- Cartridge Handling System
- Logic Assembly
- Air System
- Power Supply
- Read/Write Heads

Figures 1-1, 1-2, and 1-3 illustrate the locations; subsequent paragraphs describe the functions of each of the major assemblies and systems.

1.5.1 Controls and Indicators

The controls and indicators (Figure 1-4) required for normal operation are located on the front of the drive cabinet. Table 1-2 describes the function of each control or indicator.

1.5.2 Spindle and Drive

The spindle and drive system (Figure 1-5) comprises the spindle, spindle drive motor, and the recording disk. A 50/60 Hz, split-phase ac motor transfers torque (via the drive belt) to the spindle drive pulley. Belt tension is maintained by a tension spring anchored to the baseplate.

The spindle speed is electronically tested by a circuit that measures the INDEX PULSE interval. When the interval increases to approximately 45 ms, indicating an unsafe speed, the drive is cycled down. If the RUN/LOAD switch is placed in the LOAD position, ac power is removed from the motor, and the spindle coasts to a halt.

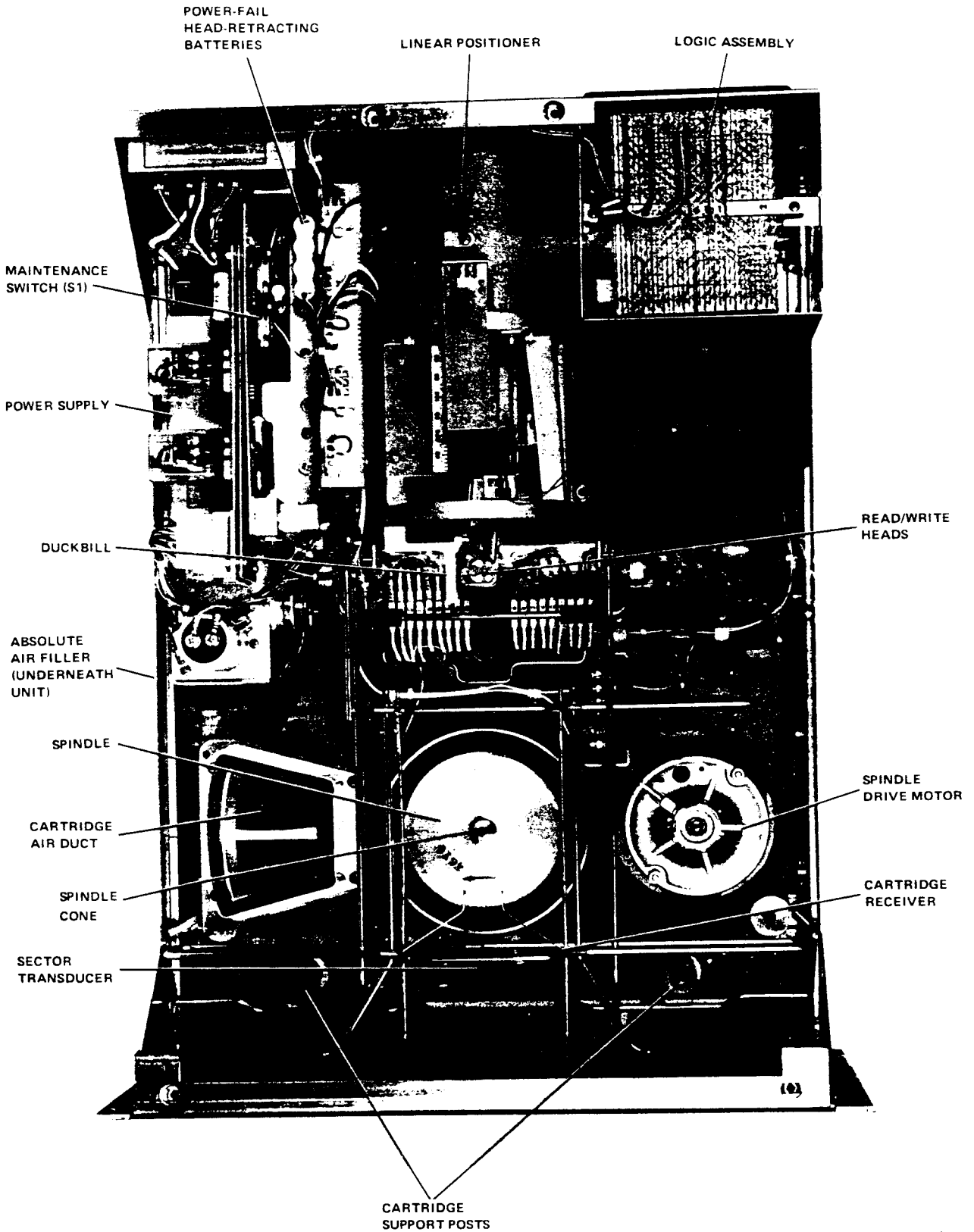
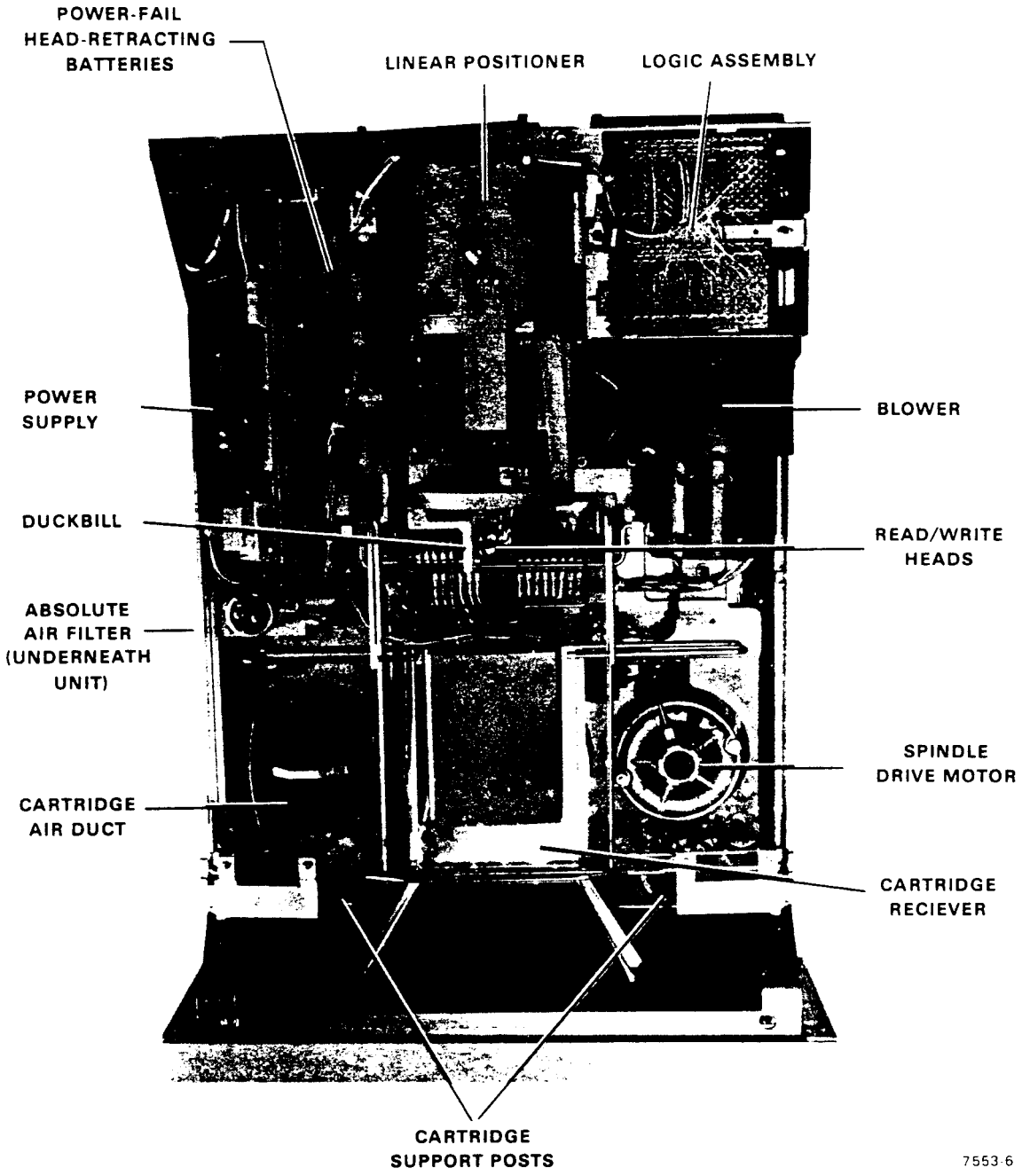

Figure 1-1 Location of Major Assemblies and Systems (RK05)



7553.6

Figure 1-2 Location of Major Assemblies and Systems (RK05-J)

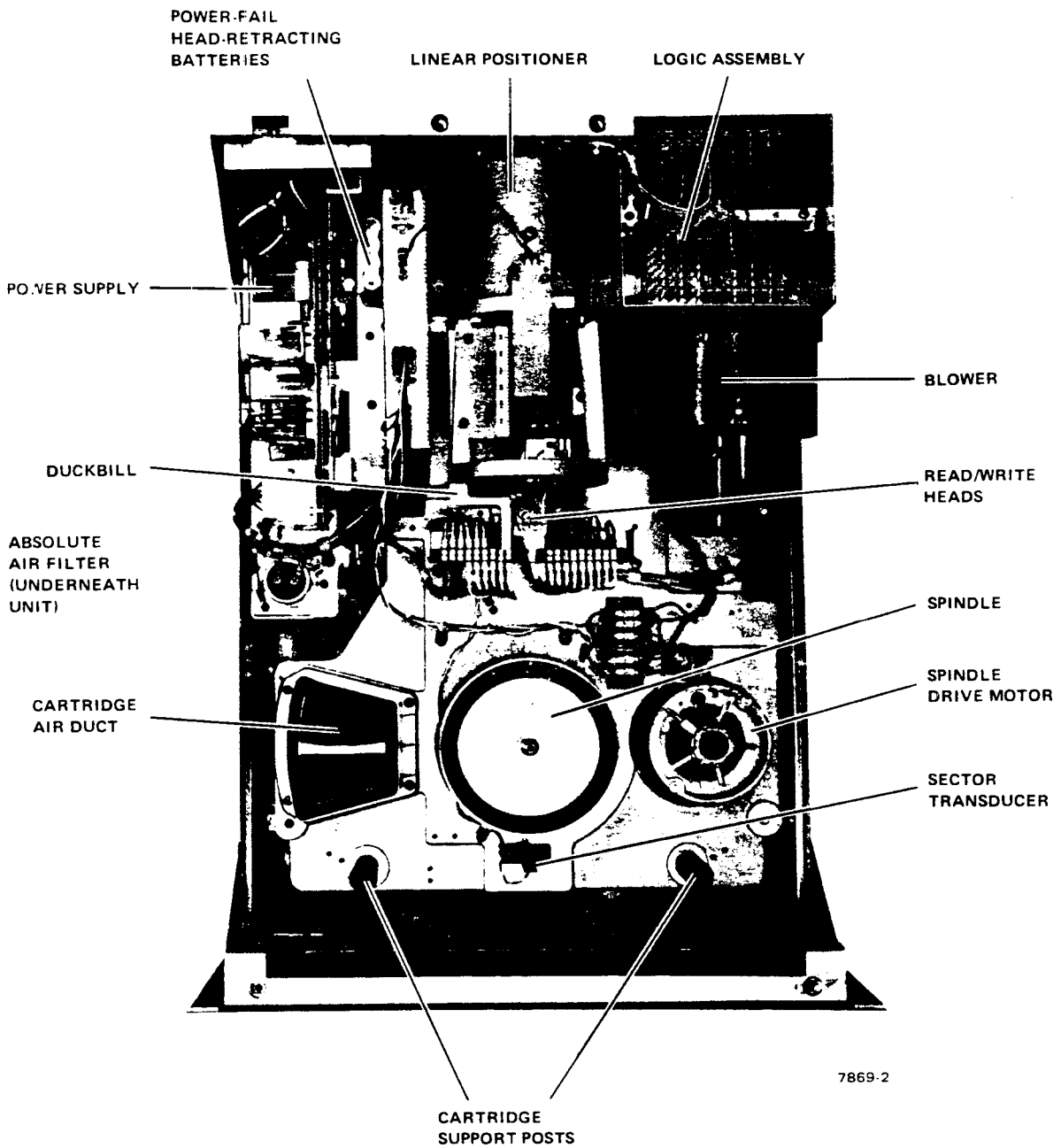

Figure 1-3 Location of Major Assemblies and Systems (RK05-F)

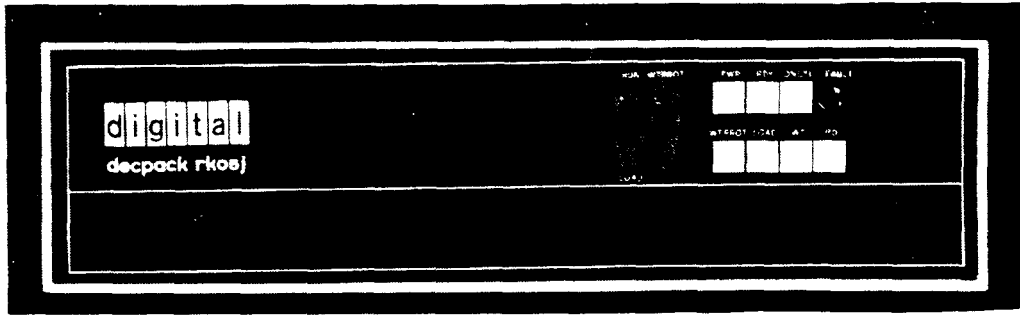

Figure 1-4 Controls and Indicators

Table 1-2 Controls and Indicators for the RK05, RK05-J, and RK05-F

Controls and Indicators	Description
RUN/LOAD (rocker switch)	<p>Placing this switch in the RUN position (provided that all interlocks are safe):</p> <ol style="list-style-type: none"> 1. locks the drive front door 2. accelerates the disk to operating speed 3. loads the read/write heads 4. lights the RDY indicator. <p>Placing this switch in the LOAD position:</p> <ol style="list-style-type: none"> 1. unloads the read/write heads 2. stops the disk rotation 3. unlocks the drive front door when the disk has stopped 4. lights the LOAD indicator.
WT PROT (rocker switch spring-loaded off)	<p style="text-align: center;">CAUTION</p> <p>Do not switch to the LOAD position during a write operation; this results in erroneous data being recorded.</p> <p>Placing this momentary contact switch in the WT PROT position lights the WT PROT indicator and prevents a write operation; it also turns off the FAULT indicator, if that is lit.</p> <p>Depressing this switch in the WT PROT position a second time turns off the WT PROT indicator and allows a write operation.</p>

Table 1-2 Controls and Indicators for the RK05, RK05-J, and RK05-F (Cont)

Controls and Indicators	Description
PWR (indicator)	Lights when operating power is present. Goes off when operating power is removed.
RDY (indicator)	<p>Lights when:</p> <ol style="list-style-type: none"> 1. the disk is rotating at the correct operating speed. 2. the heads are loaded. 3. no other conditions are present (all interlocks safe) to prevent a seek, read, or write operation. <p>Goes off when the RUN/LOAD switch is set to LOAD.</p>
ON CYL (indicator)	<p>Lights when:</p> <ol style="list-style-type: none"> 1. the drive is in the Ready condition. 2. a seek or restore operation is not being performed. 3. the read/write heads are positioned and settled. <p>Goes off during a seek or restore operation.</p>
FAULT (indicator)	<p>Lights when:</p> <ol style="list-style-type: none"> 1. erase or write current is present without a WRITE GATE. 2. the linear positioner transducer lamp is inoperative. <p>Goes off when the WT PROT switch is pressed, or when the drive is recycled through a RUN/LOAD sequence.</p>
WT PROT (indicator)	<p>Lights when:</p> <ol style="list-style-type: none"> 1. the WT PROT switch is pressed. 2. the operating system sends a Write Protect command. <p>Goes off when the WT PROT switch is pressed a second time, or when the drive is recycled through a RUN/LOAD sequence.</p>
LOAD (indicator)	Lights when the read/write heads are fully retracted and the spindle has stopped rotating.
WT (indicator)	Lights when a write operation occurs. Goes off when the write operation terminates.
RD (indicator)	Lights when a read operation occurs. Goes off when the read operation terminates.

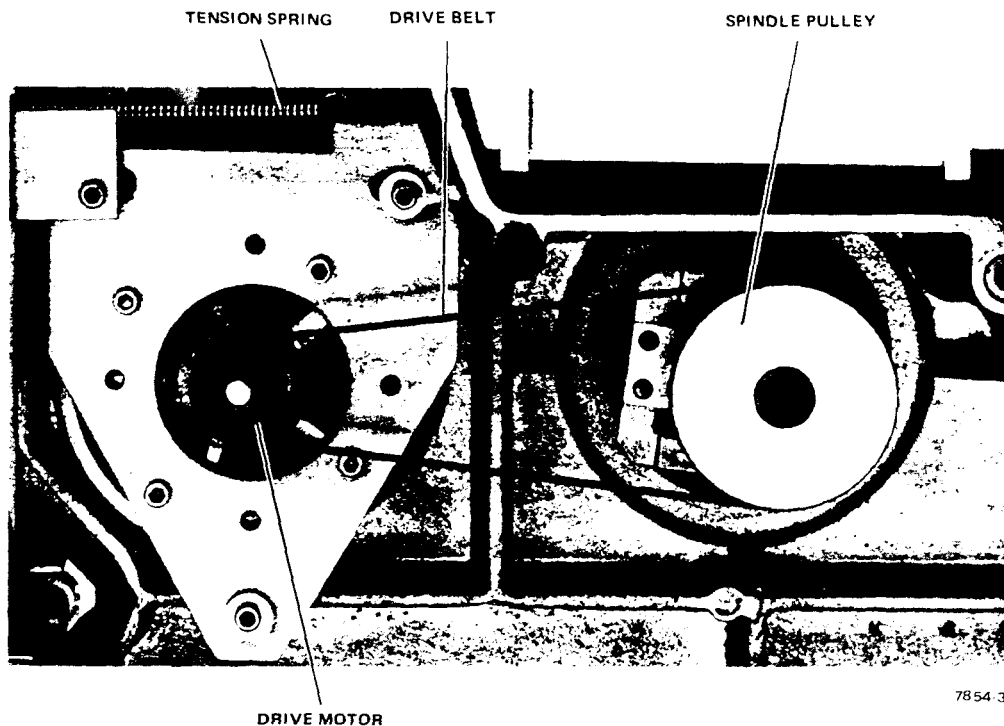

Figure 1-5 Spindle and Drive System

1.5.3 Linear Positioner

The linear positioner (Figures 1-1, 1-2, or 1-3) consists of the linear motor, the carriage, the read/write heads, and the linear positioner transducer. To move the read/write heads across the recording disk, dc current is applied to the bobbin-wound armature (Figure 1-6) of the linear motor. The resulting magnetic field reacts with a permanent magnet in the motor housing to either pull the armature into or force it out of the permanent magnetic field, depending upon the polarity of the current applied to the armature. This motion is transferred to the carriage, which is fastened to the armature. As a result, the read/write heads, which are attached to the carriage, move across the surface of the disk.

Any carriage movement is detected by the linear positioner transducer, which is located on the underside of the carriage. The transducer output is used with the control logic to determine the cylinder position of the heads, and in the servo logic to govern the speed of carriage travel.

1.5.4 Cartridge-Handling System

Cartridge handling differences exist among the RK05 family drives. The RK05 Disk Drive cartridge system (Figure 1-7a) consists of a cartridge receiver, two receiver lifting cams, an access door opener, a duckbill, and two cartridge-support posts. During normal operation, the plastic cartridge is located *only* by the duckbill and support posts. The cartridge merely *guides* the cartridge into position to be picked up by the duckbill and support posts, allowing the recording disk to rotate freely on the spindle. The rotating spindle drives the disk by magnetic coupling at the disk hub.

As the drive front door is opened, the lifting cams rotate to elevate the receiver to a slanted position, and the magnetic coupling at the disk hub is released. When the disk cartridge is inserted into the receiver (Figure 1-7b), the access door opener makes contact with and opens the access door in the rear of the top cover, permitting entry of the read/write heads.

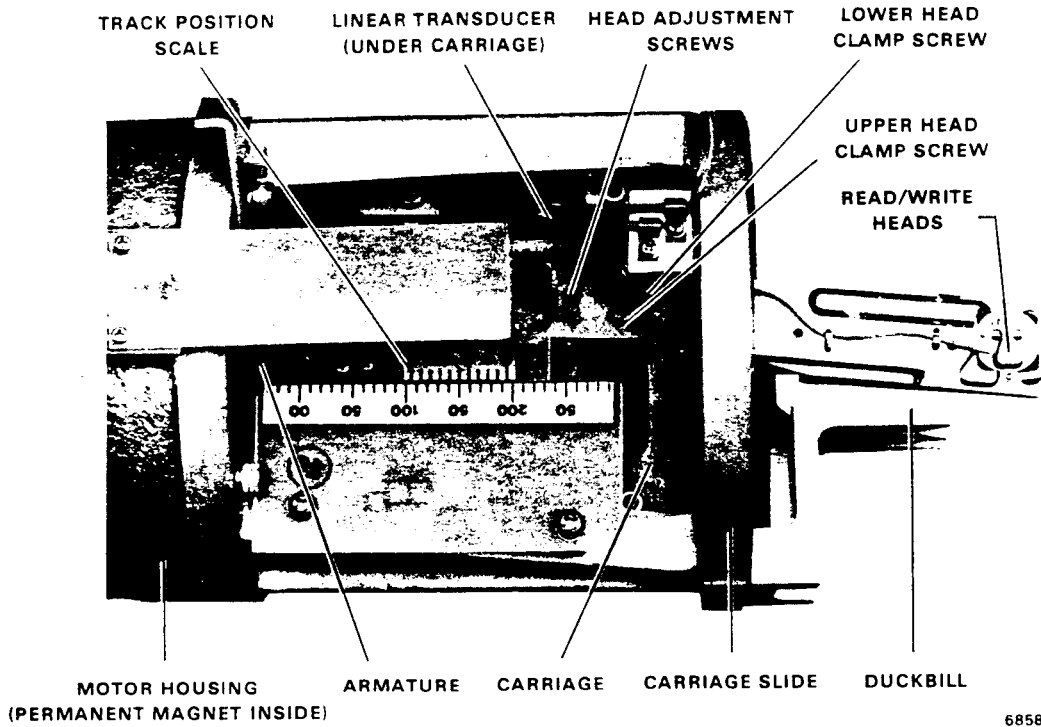

6858-b

(a) Older Style

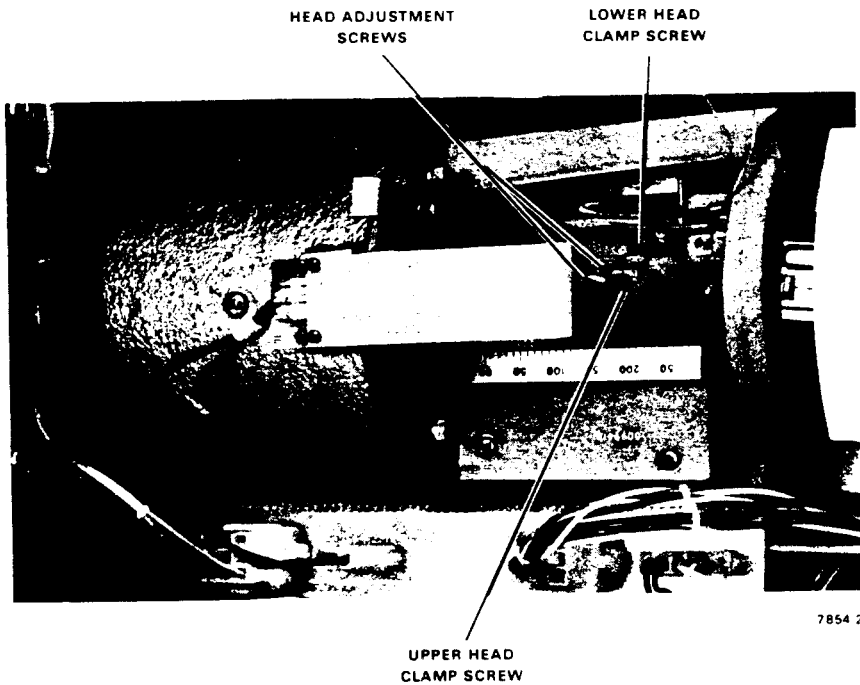

7854 2

(b) New Style

Figure 1-6 Linear Positioner (RK05/RK05-J/RK05-F)

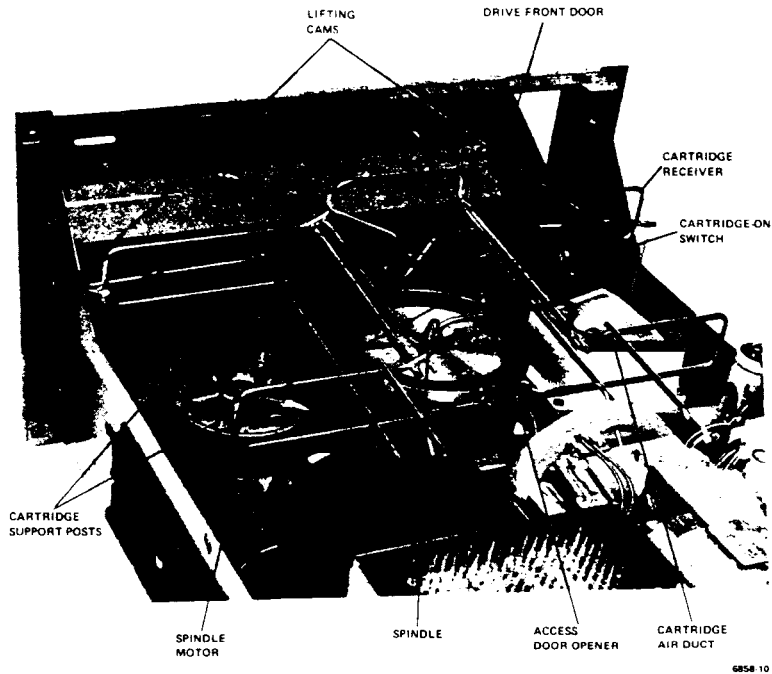

(a) Cartridge Removed

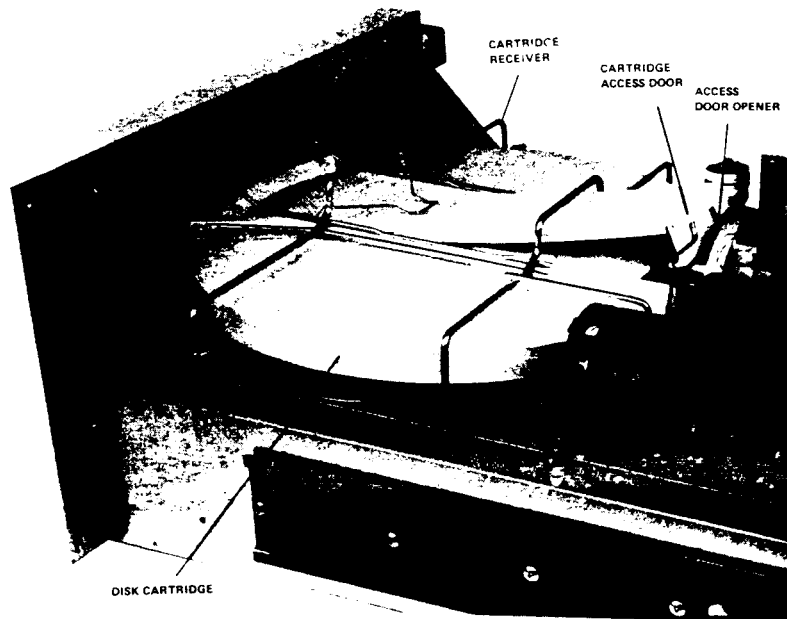

(b) Cartridge Inserted

Figure 1-7 RK05 Cartridge-Handling System

As the drive front door is closed, the cartridge is lowered to the operating position and the magnetic coupling again engages the disk hub. When the cartridge is in the operating position, the plastic case depresses the cartridge-on switch and removes the no-cartridge interlock condition. The cartridge receiver should *not* hold the cartridge tightly.

The RK05-J cartridge-handling system (Figure 1-8) is generally similar to that of the RK05, with the exception that two cartridge clamps have been added to provide a positive cartridge location force. As the drive front door is opened, the lifting cams rotate to elevate the cartridge receiver, and to lift the cartridge clamps away from the cartridge, thus freeing the cartridge for removal. As the door is closed, the receiver is lowered, and the cartridge clamps are simultaneously brought down on the upper surface of the cartridge to ensure proper cartridge seating on the cartridge support posts. In all other functional aspects, the RK05 and RK05-J cartridge-handling systems are similar.

Because the RK05-F has a fixed cartridge, its cartridge-locating system is considerably simpler, consisting of a duckbill, a door-opening wedge, two cartridge-support posts, two cartridge-retaining springs, and a cartridge-guide bracket. When the drive is prepared for initial operation at the customer's site, the retaining springs are attached (Figure 1-9b) to the front of the cartridge and the cartridge door-opening wedge is inserted. The cartridge is then guided through the front of the drive and into position on the duckbill by the cartridge-guide bracket and the cartridge-support posts, and secured with the cartridge-retaining springs (Figure 1-9b).

1.5.5 Logic Assembly

The logic assembly (Figures 1-1, 1-2, and 1-3), in the right-rear portion of the disk drive, holds eight printed circuit cards. Three of these cards contain the system logic and the read/write circuits. Two cards contain the positioner servo logic. One card is the cable connector that interfaces the electronics with the positioner and other chassis-mounted components. The remaining two cards contain the interface cables and terminators.

1.5.6 Air System

The air system (Figure 1-10) consists of the prefilter, blower, cooling duct, inlet port, absolute filter, outlet port, and air duct. As the blower rotates, unfiltered air is drawn through the prefilter, where it is purged of large particles. The prefiltered air is then drawn across the logic assembly and through the blower. Upon leaving the blower, approximately 30 percent of the air is channeled through the cooling duct and directed onto the power supply. The remaining air from the blower is fed via the inlet port into the absolute filter, where minute contamination is removed. The cleaned air is then taken to the disk cartridge air door via the filter outlet port and the air duct. After passing through the disk cartridge, the air circulates across the linear positioner and baseplate; it then exits the drive through exhaust louvers in the front panel and in the chassis side next to the power supply.

1.5.7 Power Supply

The power supply (Figures 1-1, 1-2, and 1-3), in the left-rear portion of the disk drive, furnishes all dc voltages for the drive. The power supply can operate with a 115 or 230 Vac, 50 or 60 Hz line voltage input (Paragraph 4.6).

1.5.8 Read/Write Heads

Disk drives in the RK05 family contain two ramp-loaded read/write heads. One head functions on the top surface of the recording disk, and the other one functions on the bottom surface. The heads are mounted on suspension arms that rest, when the heads are unloaded, on a plastic cam block of the duckbill (Figure 1-11). Flat cantilever springs connect the suspension arms to the head-support tailpieces. When the drive is placed in RUN mode, the positioner moves the heads forward toward cylinder zero. When the entire head slider pad has passed the edge of the disk, a ramp on the suspension arm slides down the edge of the plastic cam block, thereby moving (loading) the heads close to the disk surface. When loaded, the heads "fly" 80 to 100 microinches from the disk surface (Figure 1-12).

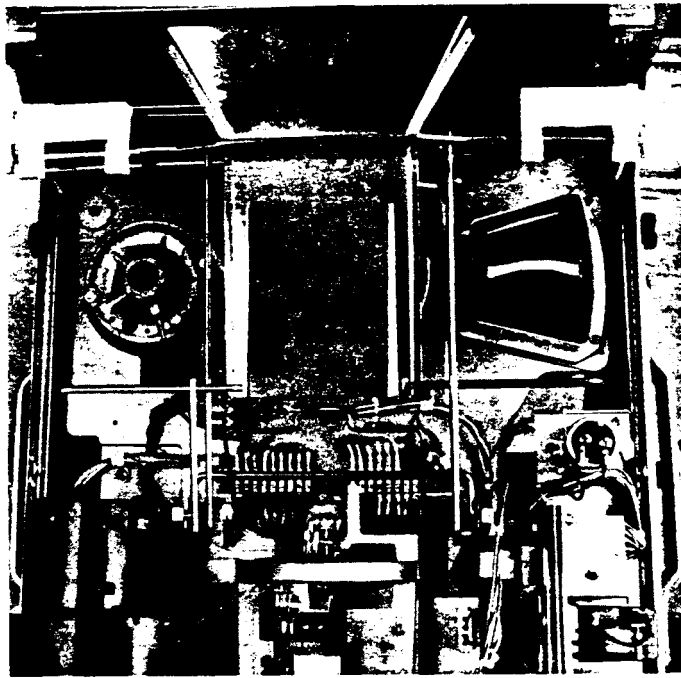

(a) Cartridge Removed

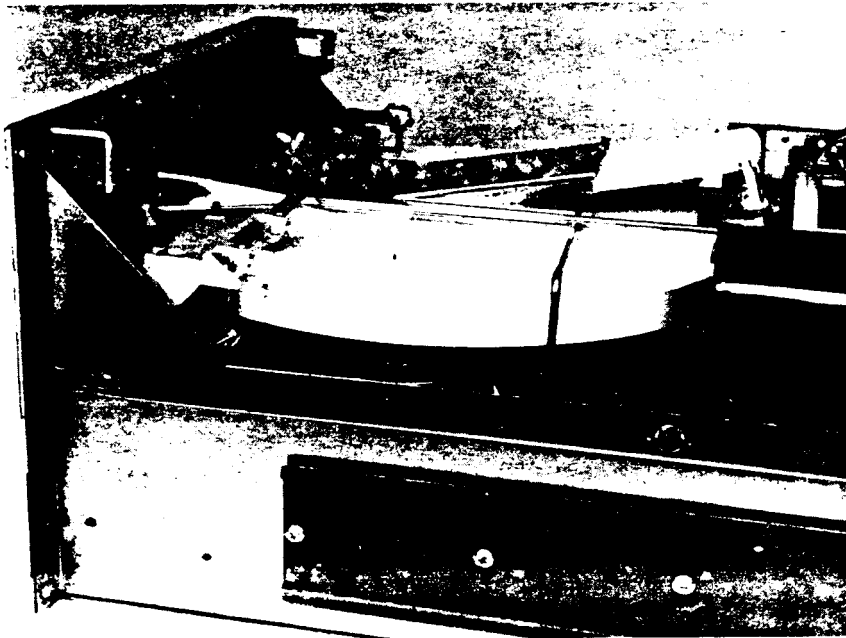

(b) Cartridge Inserted

Figure 1-8 RK05-J Cartridge-Handling System

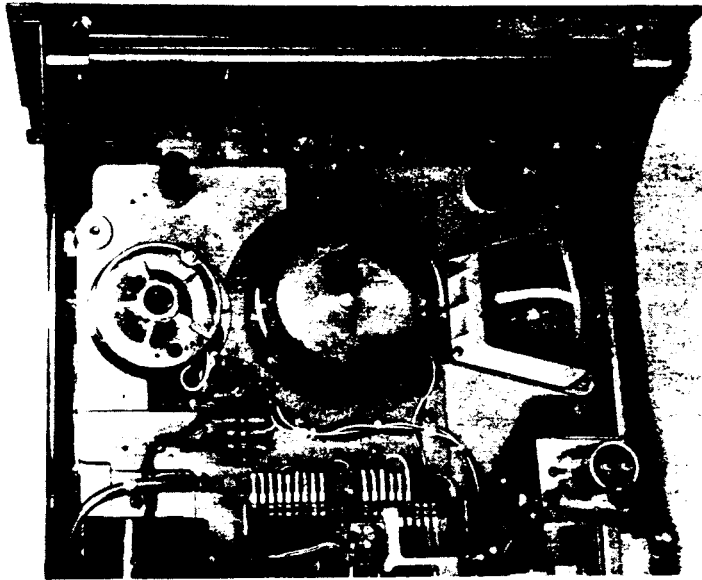

7854-6

(a) Cartridge Removed

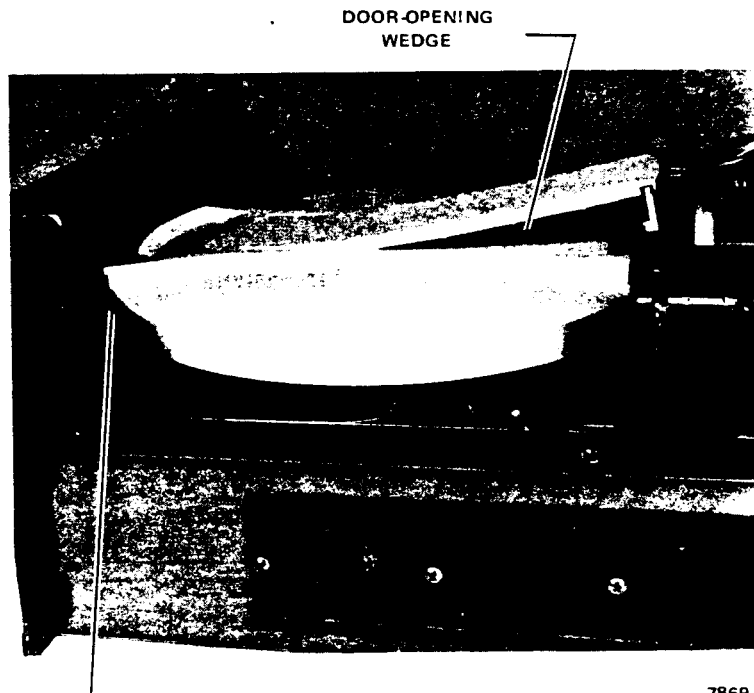

DOOR-OPENING
WEDGE

SPRINGS ATTACHED TO
FRONT OF CARTRIDGE
TO HOLD IN PLACE

7869-4

(b) Cartridge Inserted

Figure 1-9 RK05-F Cartridge-Handling System

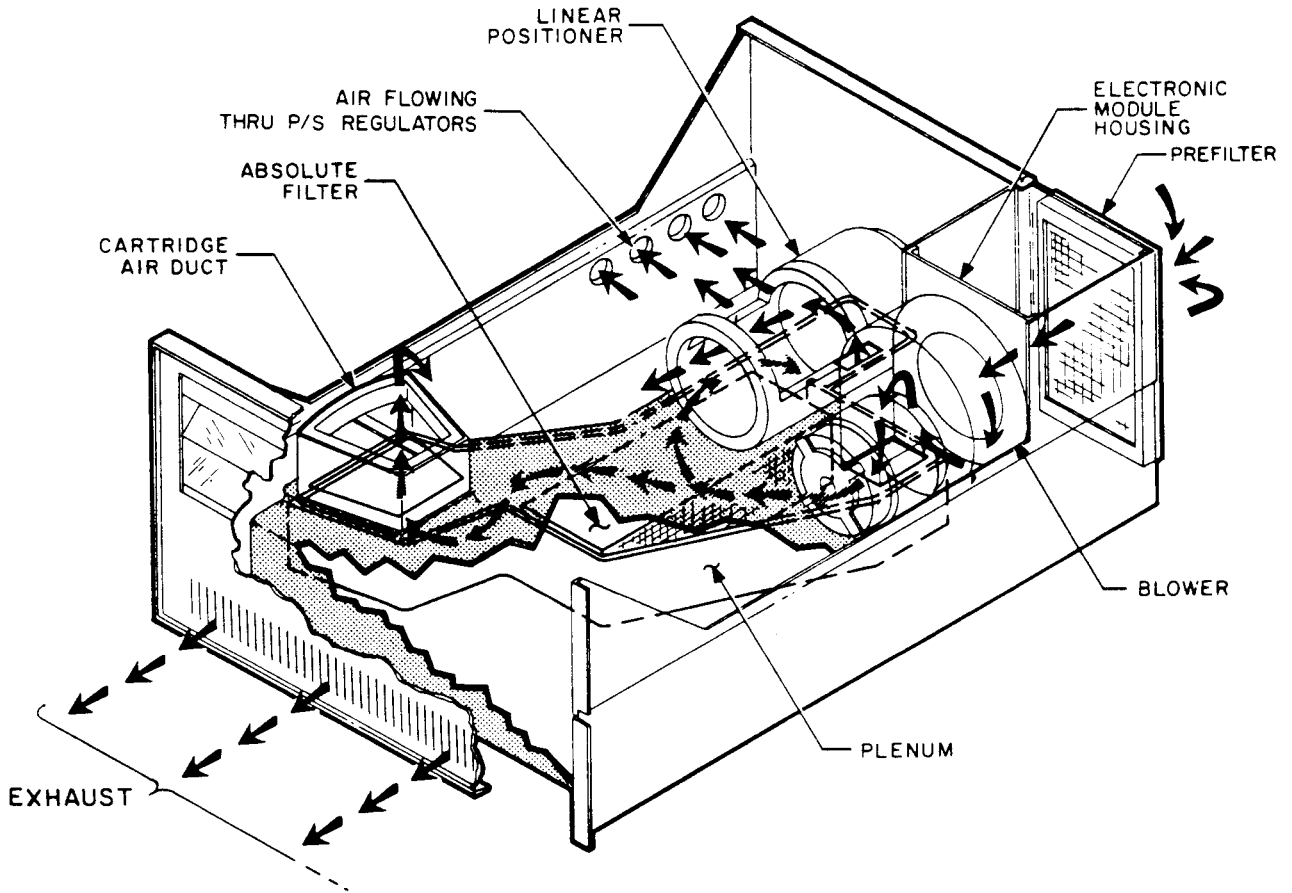

CP-0272

Figure 1-10 Air System

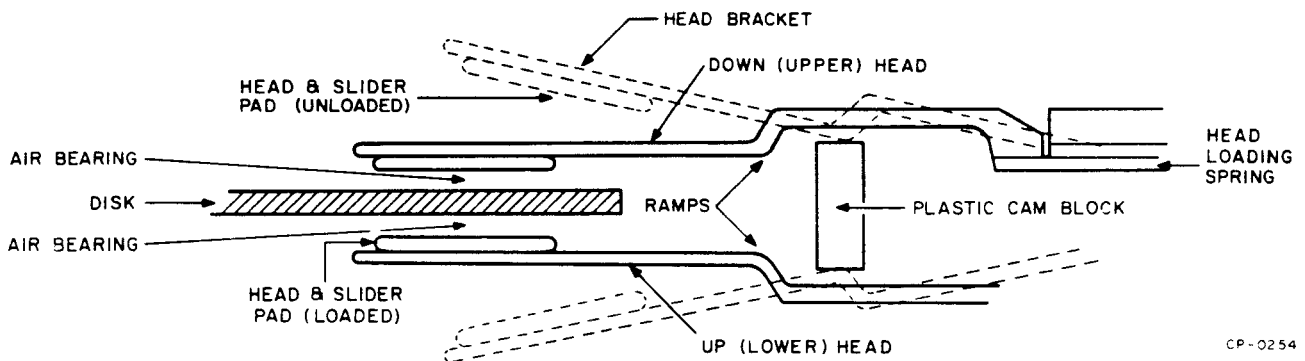

CP-0254

Figure 1-11 Head Loading

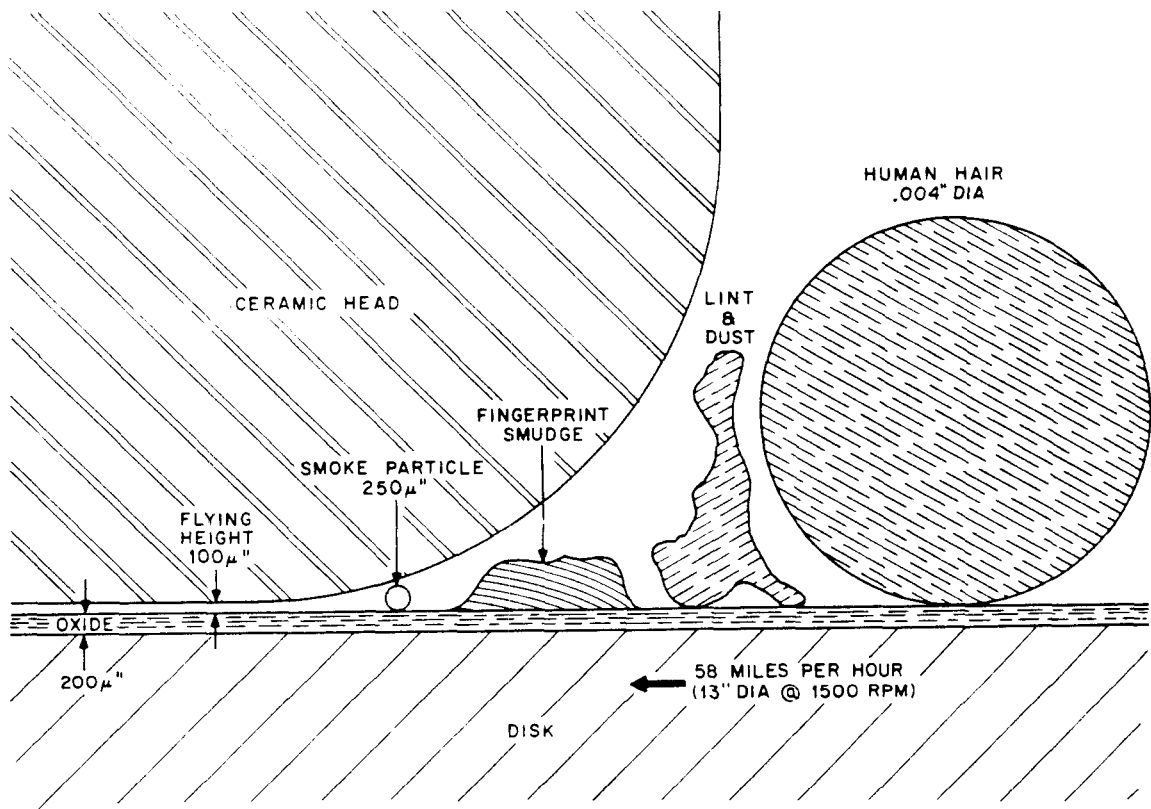

08-0884

Figure 1-12 Relationship of Disk Head, Disk, and Contaminants

A film of air (air bearing) between the disk and the head acts as a force away from the disk, while the cantilever spring is a counterbalancing force toward the disk. Thus, as long as the disk rotation remains constant, the heads remain at a relatively constant distance away from the disk surface.

The Down (upper) Head is so-called by convention throughout the computer industry because it faces down; the Up (lower) Head faces up. These designations were created to describe heads loaded onto a multisurface (10 or 20) cartridge.

The recording device (read/write head) is a coil-wound ferrite core with an air gap. As current flows through the coil, the induced flux magnetizes the surface of the disk passing under the gap. During a write operation, when the current direction in the coil is reversed, a flux reversal is recorded on the disk. During a read operation, the previously-recorded flux pattern on the disk induces current in the head. Any flux reversal on the recording surface produces a pulse.

CHAPTER 2 INSTALLATION

2.1 UNPACKING AND INSPECTION

An RK05, RK05-J, or RK05-F Disk Drive can be shipped in a rack as an integral part of a system or in a separate container. If the drive is shipped in a rack, the rack should be positioned in the final installation location and unpacked as follows:

1. Remove the cabinet shipping brackets from the drive by removing the snap-on bezel beneath the lowest drive.
2. Remove the screws attaching the shipping bracket and latch molding to both sides of the drive. The drive may now be extended on the chassis slides.

CAUTION

Do not use the front door handle of the RK05 or RK05-J to pull the drive out from the rack.

3. Slide the drive out about 3 inches from the rack and pull the shipping brackets out from the sides of the drive. Replace the latch molding and the shipping bracket screws.
4. Slide the lowest drive out far enough to gain access to the shipping brackets on the drive directly above it, and remove the screws from these two shipping brackets.
5. Repeat Steps 3 and 4 for each drive in the rack.
6. Remove the drive bottom cover and remove the screws that attach the three internal shipping brackets to the baseplate (Figure 2-1a). (A 3/16-inch Allen wrench is required.)

CAUTION

Do not operate drive with shipping brackets attached.

7. If drives in the RK05 family are "daisy-chained" with RK03 drives in a multidrive installation, arrange the RK05s consecutively at the controller end of the bus to avoid interruption of the AC LOW and DC LOW interface lines, which are not carried by the RK03s. If this arrangement is not possible, all RK05s that are separated on the bus by RK03s must be connected by separate cables between their J06 connections (Figure 2-2).
8. Remove the drive top cover and remove the mounting screw and shipping strap from the linear positioner (Figure 2-1b). Turn the shipping strap upward and replace it on the linear positioner, making sure that it is tightly secured.

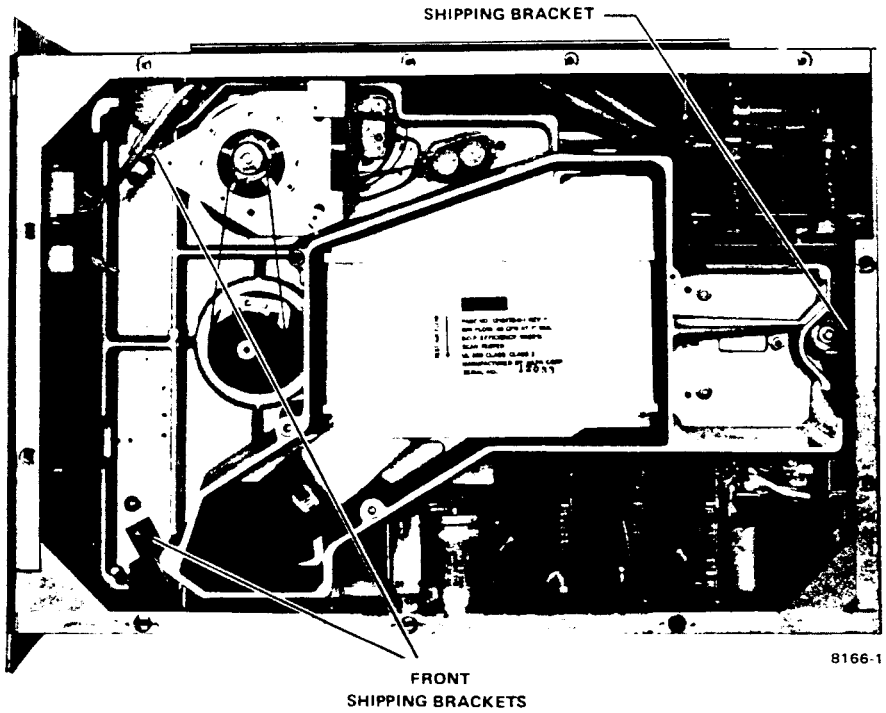

(a) Shipping Brackets

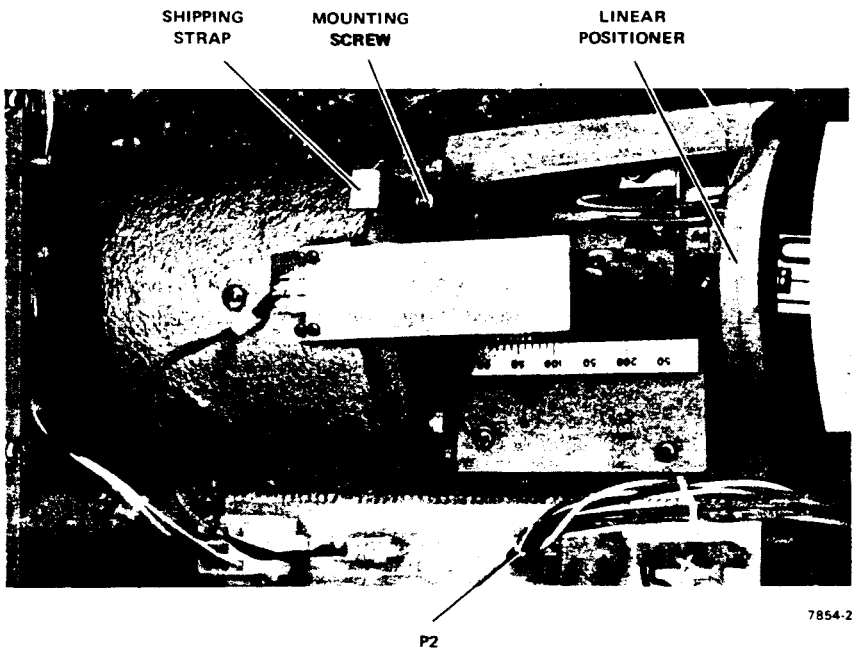

(b) Shipping Strap on Linear Positioner

Figure 2-1 Shipping Bracket and Shipping Strap Locations

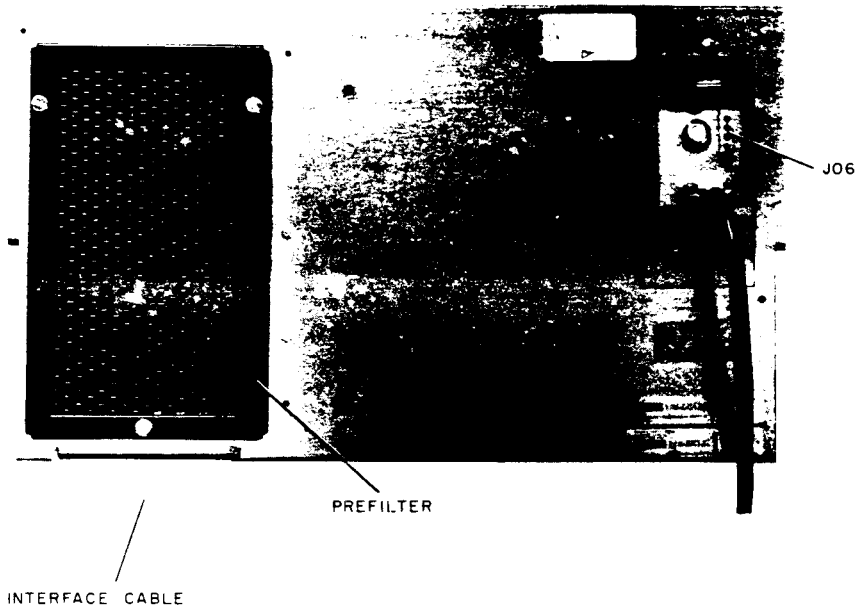

Figure 2-2 RK11-C or RK11-D Interface Cable Installation

9. Retain all packing material for possible reshipment. Inspect the drive for possible damage. Report any damage to the carrier and to Digital Equipment Corporation.
10. In the case of RK05 family drive relocation reshipment, replace the shipping brackets and shipping strap in the shipping position; repeat this unpacking and inspection procedure when the drive is reinstalled.

If the drive is shipped in a separate container, use care while unpacking it. Do not drop the drive or subject it to unreasonable impact.

2.2 MECHANICAL INSTALLATION AND CHECKOUT

If the RK05-type drive is to be installed in an existing rack, the chassis slides should first be installed in the rack (Figure 2-3). The disk drive should be mounted on the chassis slides as follows: (If necessary, refer to the RK05 Option Configuration Dwg. No. D-OC-RK05-0-15 for detailed mechanical specifications of a multidrive installation.)

1. Install cabinet stabilizers before mounting the drive, unless the weight of the rack is sufficient to prevent tipping when the drive is fully extended.
2. Pull the chassis slides out until they lock in the extended position.
3. Slide the drive onto the chassis slides until it locks.
4. Remove the drive bottom cover and remove the screws that attach the three internal shipping brackets to the baseplate (Figure 2-1a).

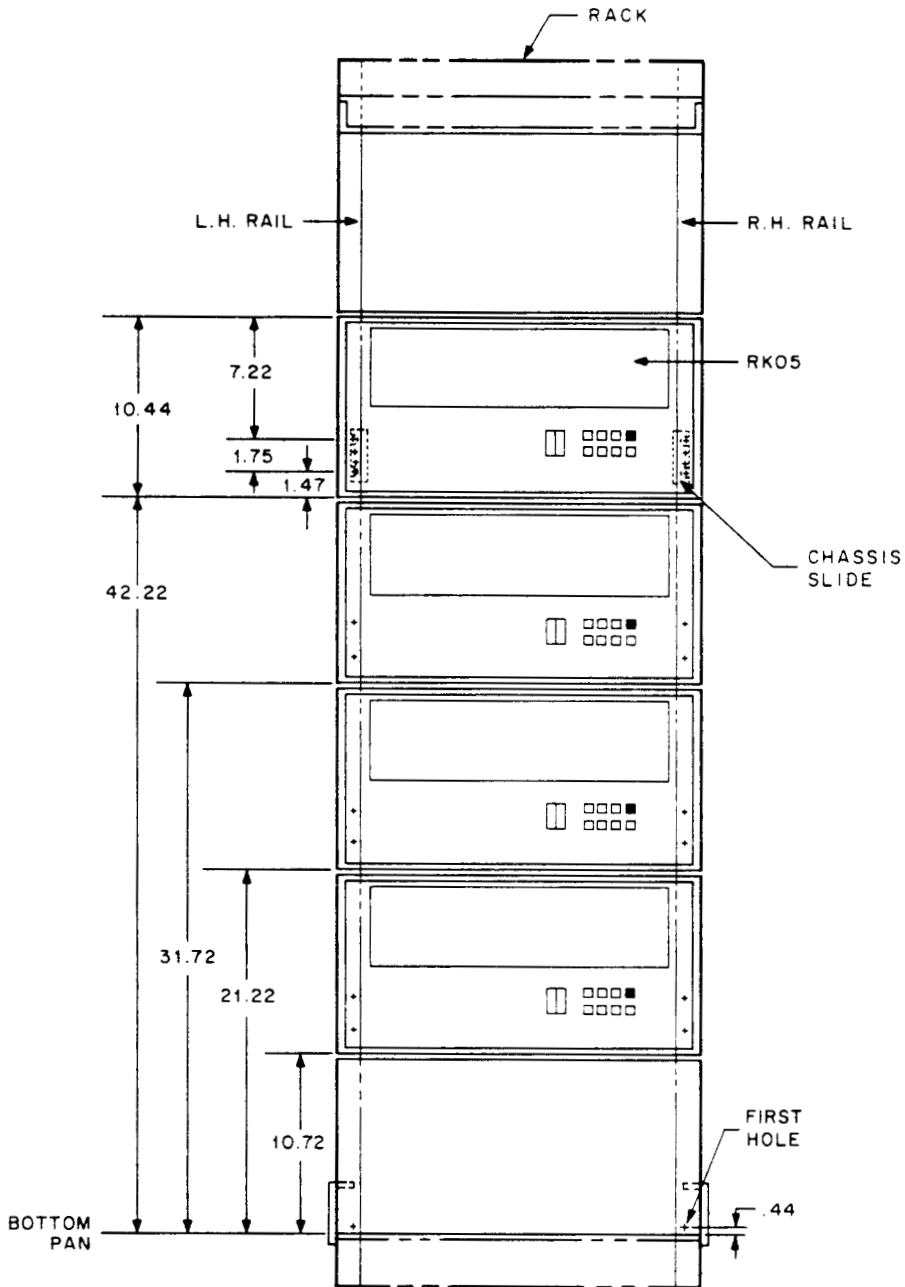

CP-0273

Figure 2-3 Chassis Slide Mounting

- Remove the drive top cover and remove the mounting screw and shipping strap from the linear positioner (Figure 2-1b). Turn the shipping strap upward and replace it on the linear positioner. Pull the heads forward as far as possible without going off the ramp (Figure 1-7) and confirm that the batteries (Figure 1-1) return the heads to the home position.

6. Inspect P2 (Figure 4-17) and the spindle pulley to ensure that the drive is configured properly for the input power to be used. If P2 contains two jumpers, the supply is configured for 115 Vac operation. If P2 contains only one jumper, the supply is configured for 230 Vac. The operating frequency is stamped on the spindle pulley.
7. Check the logic assembly to ensure that no pins are bent or broken; then plug the interface cable card into card position 7 or 8 of the logic assembly. If there is only one drive in the system, or if this is the last drive of the daisy-chain, ensure that an M930 terminator card (Dwg. No. RK05-0-2) is in the unused interface card position.
8. If RK05-type drives are daisy-chained with RK03 drives in a multidrive installation, arrange the RK05s consecutively at the controller end of the bus to avoid interruption of the AC LOW and DC LOW interface lines, which are not carried by the RK03s. If this arrangement is not possible, connect all RK05-type drives separated on the bus by RK03s by means of separate cables between their J06 connections (Figure 2-2).
9. If the drive is to be connected to other than an RK11-C or RK11-D controller, install the interface cables as follows:
 - a. Remove the prefilter and frame.
 - b. Route the interface cables through the prefilter opening and reinstall the filter and frame so that the cables fit into the slot on the side of the frame (Figure 2-4).
 - c. Route the cables over the prefilter and fold them as indicated in Figure 2-4.
 - d. Place the cable retaining bracket over the fold in the cables and fasten the bracket to the chassis.
10. If the drive is to be connected to an RK11-C or RK11-D controller, install the interface cables either as described in Step 9, above, (which is preferable) or as follows:
 - a. Fold the interface cables and route them through the slot just below the prefilter at the rear of the drive cabinet (Figure 2-4).
 - b. Hold the cables in position and replace the bottom cover.
11. To avoid random errors, confirm that the grounding strap is firmly in place between the base plate and the chassis, and that brushes are mounted securely and in the proper plane. Confirm that all connectors are securely in place.
12. Configure the M7700 or M7680 select switch to address a valid drive (Paragraph 3.2.2).
13. Plug the power cord into the switched ac line receptacle.
14. Turn the processor keyswitch ON to apply power to the drive.
15. Check that the spindle is clean, and that the heads are not bent or dirty.
16. Install a test cartridge on the spindle (Paragraph 5.4.1) and check the head alignment with a checking scope. Then run the appropriate diagnostic tests to ensure proper electrical and mechanical drive operation.

A = SINGLE FOLD
B = DOUBLE FOLD

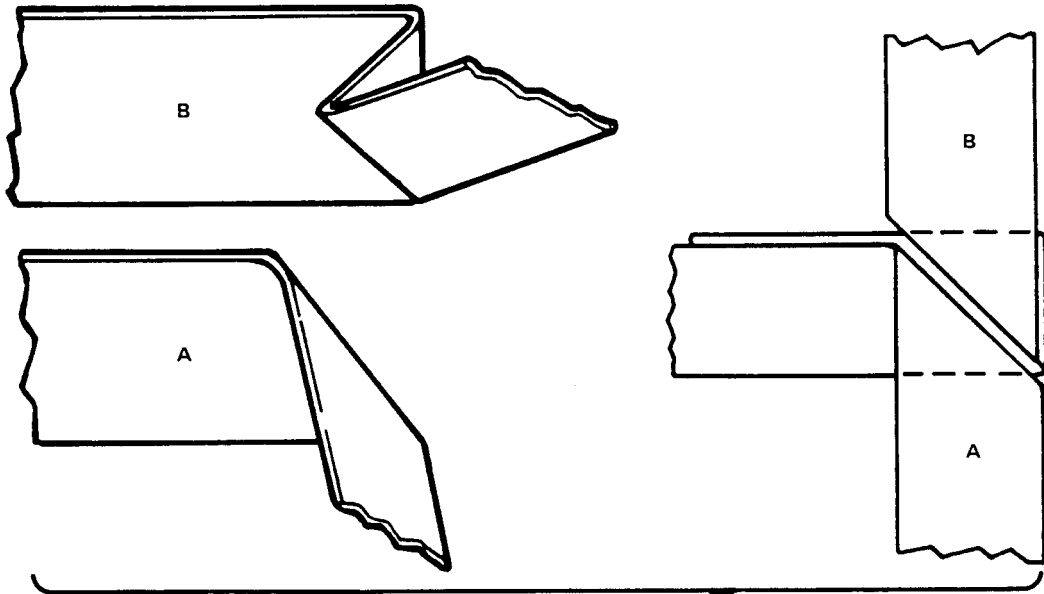

PREFILTER FRAME

INTERFACE CABLES

RETAINING BRACKET

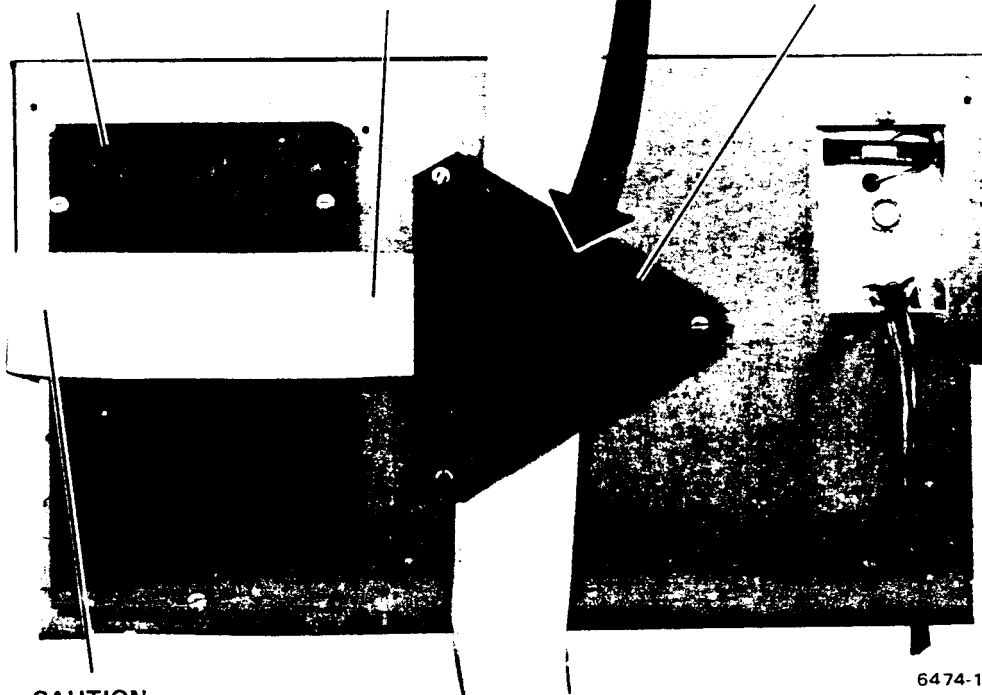

CAUTION
IF CABLE STICKS OUT TOO FAR
ON LEFT IT WILL BE DAMAGED
WHEN DRIVE IS PULLED OUT OR
PUSHED INTO CABINET

6474-12

Figure 2-4 RK8/E Interface Cable Installation

2.3 CARTRIDGE-HANDLING PRACTICES AND PRECAUTIONS

The following precautions and cartridge-handling practices must be observed with all RK05 and RK05-J cartridges, and with all RK05-F cartridges prior to their permanent installation into their RK05-F drives.

1. Store cartridges in a clean, dry area away from direct sunlight. Do not expose cartridges to heat. They may be stored on edge or stacked; however, stacks of more than 3 or 4 cartridges should be avoided. Do not place heavy items on the plastic cartridge cases. Do not store cartridges on top of computer cabinets or in places where dirt can be blown by fans into cartridge interiors.
2. Whenever a cartridge is not in a drive, enclose it in a plastic bag to exclude dust or dirt.
3. Professional cartridge cleaning is required every six months; however, disks should be cleaned whenever they are excessively dirty, or when a high transient error rate is encountered.
4. Place stiff cardboard or plastic labels only in the molded frame at the front edge of the disk cartridge without using any adhesives. Labels placed on any other part of the cartridge may interfere with the drive operation or introduce contamination into the drive or the interior of the cartridge.
5. Allow the temperature of the cartridge to become stabilized with the room temperature before using the cartridge. If cartridges are exposed to outside temperature extremes, or if the temperature differential between drive and cartridge exceeds 20° F, a two-hour stabilization period is necessary.
6. Although cartridges recorded on RK03s, RK05s, and RK05-Js are fully interchangeable, allow them to stabilize before new data is recorded on them. Data interchangeability between drives is only guaranteed if the temperature difference does not exceed 30° F (17° C), even though a specific drive/cartridge combination may operate over a temperature range of 50° to 110° F (10° to 43° C).
7. Keep the spindle hub clean and free from nicks and burrs to ensure reliable cartridge operation. Because the hub is slightly magnetic, do not expose it to metal chips that could adhere to the mounting surface. Periodically inspect the coupling hub on the bottom of the disk cartridge for dirt, metal chips, plastic chips in cone, etc.
8. A sustained tinging, scratching, or rumbling sound (*not* to be confused with spindle ground brushes) that is the result of head-to-disk contact may occur if the cartridge is not properly seated on the spindle, if excessive contamination has built up in the interior of the cartridge, or if the cartridge or the drive is defective. If this sound is heard, shut down the drive immediately to avoid damage to the read/write heads. Remove the disk cartridge and examine the heads for damage or excessive dirt. If necessary, clean or replace the heads. Do not reuse the cartridge without first checking it for surface damage.

CAUTION

NEVER CYCLE A BAD CARTRIDGE THROUGH AN INSTALLATION OF SEVERAL DRIVES. This practice can ruin all the read/write heads or contaminate all drives in a multidrive installation, which will in turn damage all other cartridges run in these drives.

9. Always keep the front door of the drive closed and keep all covers on to prevent unnecessary entry of atmospheric dirt or dust.

2.4 CARTRIDGE PACKING AND SHIPPING

Data recorded on disk cartridges may be degraded by exposure to any sort of small magnet brought into intimate contact with the disk surface. If cartridges are to be shipped in the cargo hold of an aircraft, precautions are necessary against possible exposure to magnetic sources. Because physical separation from the magnetic source is the best protection against accidental erasure of a cartridge, cartridges should be packed at least three inches within the box. This amount of separation should be adequate to protect against any magnetic sources likely to be encountered during transportation, making it generally unnecessary to ship cartridges in specially shielded boxes.

2.5 NORMAL OPERATING PROCEDURES

All drives in a multidrive system must have operating power applied even when the drive is not in use. In addition, unused drives should be left write-enabled, with the RUN/LOAD switch in the LOAD position.

**IMPORTANT
ON EARLIER MODEL RK05 DISK DRIVES
EQUIPPED WITH A POWER ON/OFF
SWITCH, DO NOT USE THE ON/OFF
SWITCH DURING SYSTEM OPERATION TO
REMOVE OPERATING POWER FROM AN
INDIVIDUAL DRIVE.**

Because the DC LOW interface signal is common to all drives in a multidrive system, a power loss in any one drive disables all the drives in the system. If the drive power is controlled by a processor keyswitch, all drive ON/OFF switches should be left ON; however, all RUN/LOAD switches should be set to LOAD before system power is removed.

2.5.1 RK05 and RK05-J Cartridge Loading

The procedure for cartridge loading is as follows:

1. Set the RUN LOAD switch on all drives to LOAD and observe that the LOAD indicator lights.

CAUTION

If the LOAD indicator is not lit, the drive front door is locked. In this case, do not attempt to force the front door open.

2. Open the front door of the drive and *gently* insert a clean, operable disk cartridge fully into the cartridge receiver. **DO NOT TWIST OR FORCE THE CARTRIDGE DURING INSERTION!**
3. Close the front door of the drive and set the RUN/LOAD switch to RUN.
4. Wait for the RDY and ON CYL indicators to light; the drive is now ready to perform seek, read, or write operations.

2.5.2 RK05 and RK05-J Cartridge Unloading

The procedure for cartridge unloading is as follows:

1. Set the RUN/LOAD switch to LOAD and observe that the RDY indicator goes out. After approximately 30 seconds, the LOAD indicator will light.
2. Open the drive front door and *gently* withdraw the disk cartridge.

3. If another cartridge is not loaded, close the drive front door to prevent unnecessary entry of atmospheric dirt or dust.
4. Store the cartridge in a clean plastic bag.

2.5.3 RK05-F Cartridge Installation

The procedure for installing cartridges in the RK05-F Disk Drive is as follows:

1. Remove power from the drive.
2. Remove the top and bottom covers and the front bezel.
3. Attach springs to the cartridge, using screws already in the cartridge (Figure 2-5). Point the hooks of the springs toward the cartridge access door. Restart screws by rotating them backward (counterclockwise) until the lead threads pass each other and the screw drops into the hole in the cartridge body with an audible click; the screws then should drive easily in the normal (clockwise) direction.

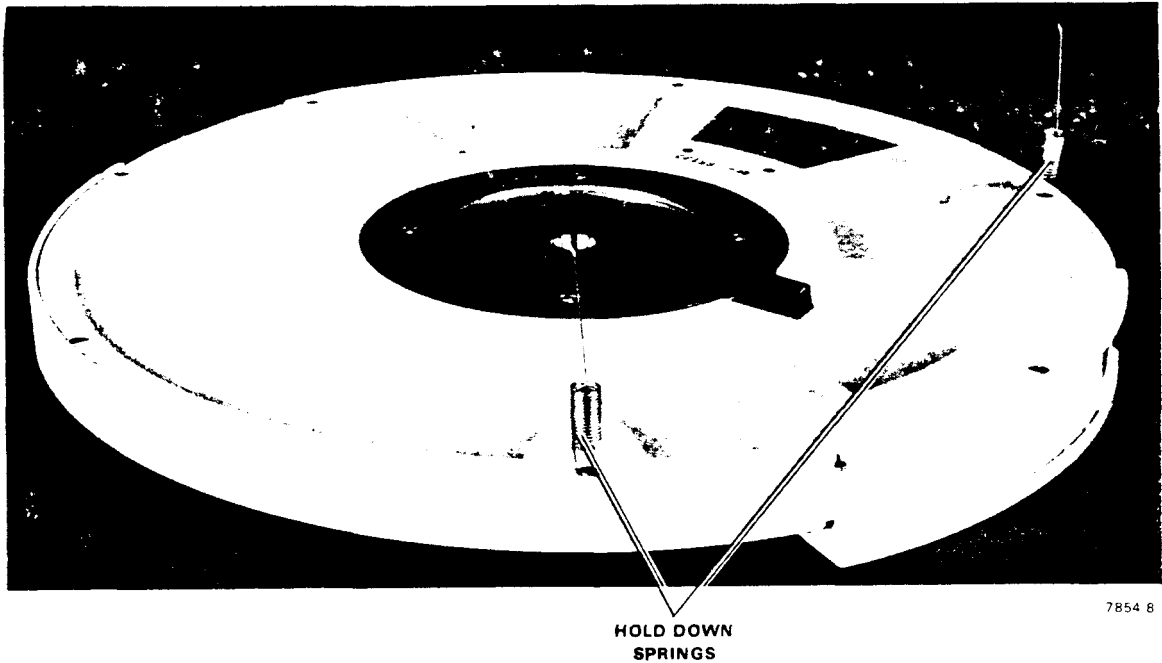

Figure 2-5 RK05-F Cartridge

4. Install plastic door-opening wedge. The circular slots in the wedge snap around the top of the retainer button, which is pulled up through the top of the cartridge when the access door is opened. Use the first slot if the serial number of the cartridge begins with A or B; use the second slot if the serial number begins with S.
5. Carefully guide the cartridge into position in the duckbill and over the cartridge-support posts. Hook the springs under the front lip of the base casting (Figure 2-6). Do not overstretch the springs when installing or removing cartridges.

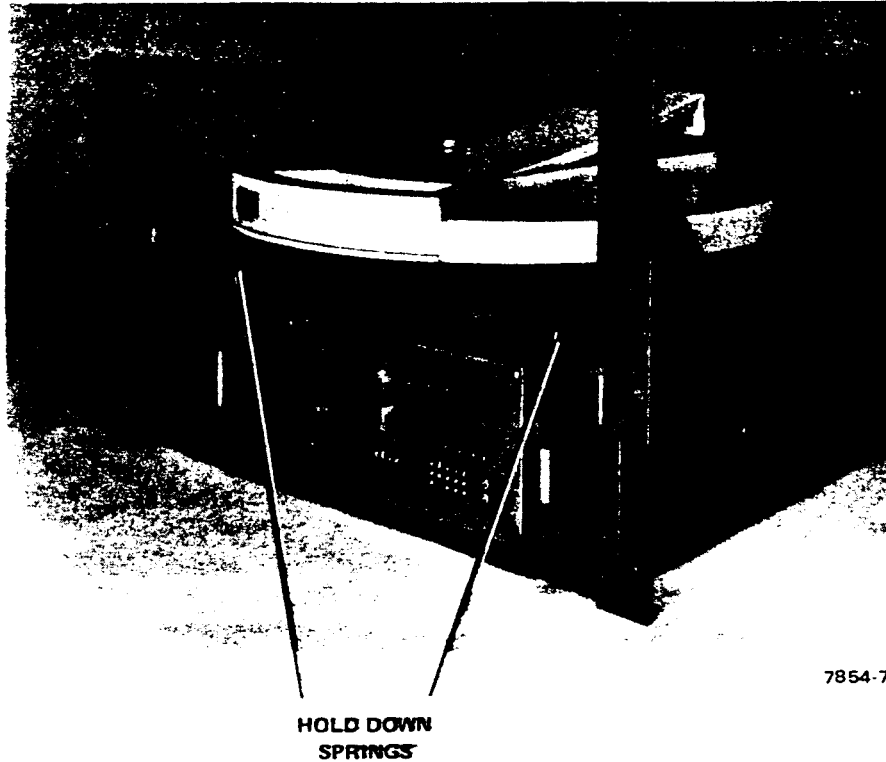

Figure 2-6 RK05-F Cartridge Installed

2.5.4 RK05-F Cartridge Removal

The procedure for removing cartridges from the RK05-F Disk Drive is as follows:

1. Remove power from the drive.
2. Remove the top and bottom covers and the front bezel.
3. Unhook the springs from the front lip of the base casting. (Do not overstretch the springs.) Using the cartridge handle, lift the cartridge straight upward. When the cartridge hub has separated from the magnetic spindle, remove the cartridge from the drive. Take care that the springs do not catch on anything during the removal process.
4. Remove the wedge, permitting the access door to close so that the interior is protected from dust.
5. Remove the springs from the cartridge before returning it to the box.

CHAPTER 3 INTERFACE

3.1 GENERAL

The flexibility achieved with the address select logic and the eight-position address select switch permits drives in the RK05 family to be connected to a variety of computer systems. In the RK11-C and RK8/E systems, up to four logical drives can be serially connected to a single bus; in the RK11-D system, up to eight logical drives can be serially connected. (Each RK05-F Disk Drive is equivalent to two logical drives contained in a single unit.)

Interface cable connection of the RK05 Disk Drive is made to card position 7 or 8 of the electronic module. These card positions are parallel-wired so that several drives may be daisy-chained in a multi-drive configuration; that is, card position 7 or 8 of the first drive is connected to card position 7 or 8 of the succeeding drive, etc. (By convention, card position 7 is used for input signals; card position 8 is used for output signals.) If there is only one drive in the system, an M930 terminator card must be installed in the unused interface card position; if there is more than one drive in the system, only the last drive on the bus must have the M930 terminator card in the unused interface card position. The interface signal levels are determined by the M930 terminator card. An assertion, or logic 1, is approximately +0.5 Vdc, and a negation, or logic 0, is approximately +3.5 Vdc.

Figure 3-1 illustrates and the following paragraphs describe the function of each interface line. The signals listed, being bus signals, operate according to negative logic; they are asserted low.

3.2 INPUT INTERFACE LINES

3.2.1 RK11-D

This line (BUS RK11-D L) transmits a signal that configures the address select logic to operate with a particular controller type. A logical 0 on this line indicates that the controller is not an RK11-D (thus, the controller is either an RK11-C or an RK8/E, both of which control only four drives on a single bus), while a logical 1 indicates that the controller is an RK11-D.

3.2.2 Select (4 Lines)

BUS SEL DR 0/A/E, 1/B/F, 2/C/H, and 3/D/J L operate in conjunction with the RK11-D interface line and an eight-position address select switch on the M7700/M7680 card to determine the drive address assignment and selection by one of the following two methods:

1. With a logical 0 on the RK11-D line, the M7700/M7680 selection circuit is configured to decode the four selection lines as a linear set. In a particular drive, only one of the four lines is internally connected (via positions 0 through 3 of the address select switch) to the drive control logic. To select a drive, the controller places a logical 1 on the desired select line. This line remains at logical 1 during the entire data transfer or control operation. (RK05-F drives can occupy positions 0 and 1 or 2 and 3, and can be selected by a logical 1 on either of the two positions.)

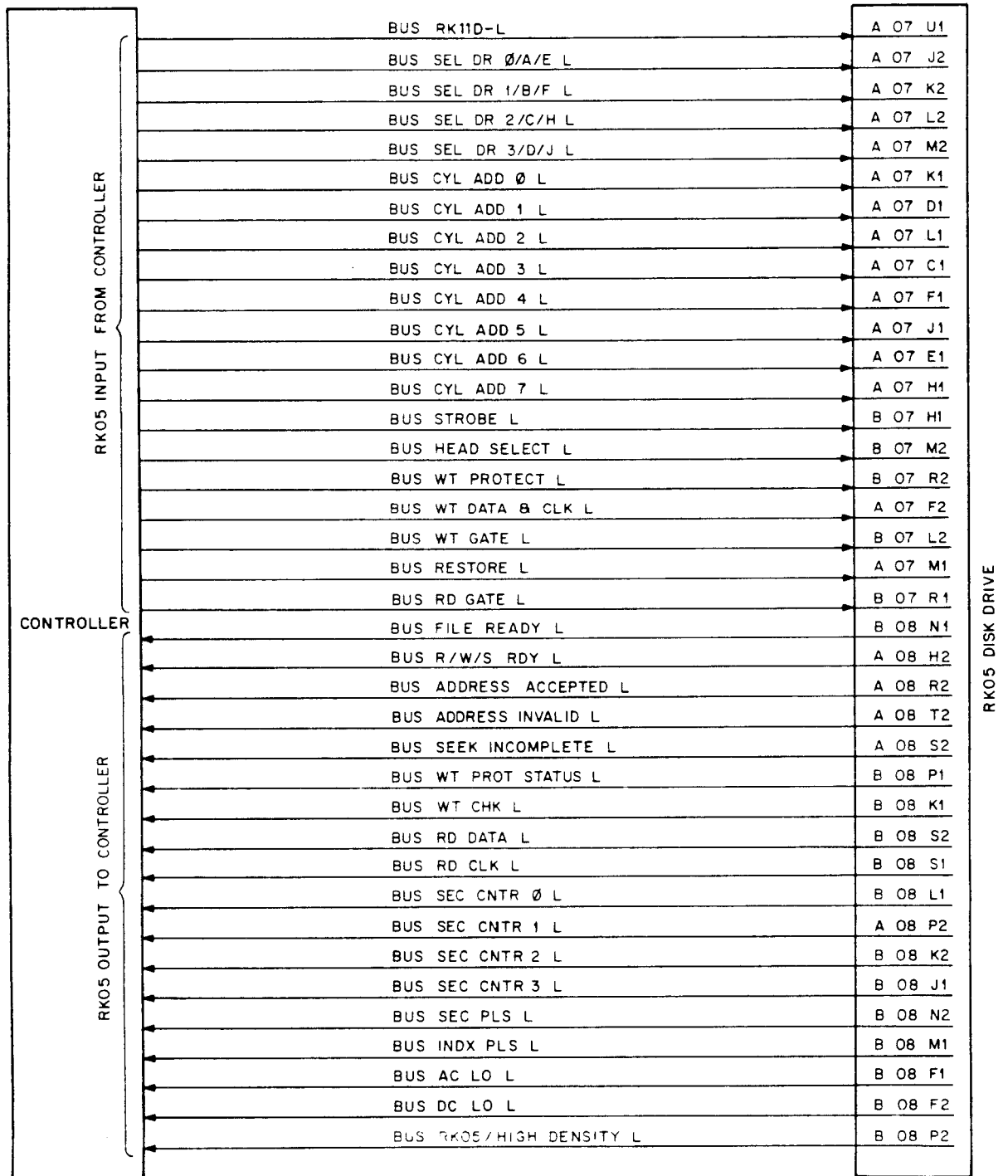

CP - 0841

Figure 3-1 Controller/RK05 Disk Drive Interface Lines and Pin Assignments

2. With a logical 1 on the RK11-D line, the M7700/M7680 selection circuit is configured to decode the four selection lines as a binary-encoded set. To select a drive, the controller places a 3-bit binary code, which corresponds to the drive address, on these select lines. This binary code is then translated by a three-line-to-eight-line decoder to activate only one of the eight address select switch positions. (RK05-F drives can occupy positions 0 and 1, 2 and 3, 4 and 5, or 6 and 7; selection of either of the positions occupied by a drive selects that drive.)

The M7680, which is completely downward-compatible with the RK05-J, differs from the M7700 only in that it generates an ODD DRIVE L signal by decoding the input select lines. This signal, which is completely internal to the drive, determines whether the outer (even) or inner (odd) half of the disk is used.

The RK05-J/RK05-F select switch, when in the "F," or closed position, wires drive select positions together by pairs (0/1, 2/3, 4/5, 6/7). The "J," or open position, maintains downward compatibility.

3.2.3 Cylinder Address (8 Lines)

BUS CYL ADD 0 L through BUS CYL ADD 7 L determine the cylinder position of the read/write heads. In order to move the heads to a desired cylinder, the controller places a corresponding 8-bit binary code on the lines (valid codes = 0 through 202₁₀). These lines are gated by the Strobe signal to position the heads at the selected cylinder. The binary code remains on the lines until either the Address Acknowledged or the Address Invalid signal is returned from the drive (Paragraph 3.3.3).

3.2.4 Strobe

BUS STROBE L transmits a signal that gates the Cylinder Address or Restore line. The controller places a logical 1 on the Strobe line only after the Cylinder Address or the Restore signals are fully settled on their respective lines. The Strobe line remains at logical 1 until either the Address Acknowledged or the Address Invalid signal is returned from the drive.

3.2.5 Head Select

BUS SEL UPPER HD L transmits a signal that determines which of the two read/write heads is to be selected. The controller places a logical 1 on this line to select the upper head, and a logical 0 to select the lower head. Either signal remains on the line throughout the entire read or write operation.

3.2.6 Write Protect Set

BUS WT PROTECT L transmits a signal that disables the drive write amplifiers to prevent a write operation. The controller places a logical 1 on this line to set the Write Protect flip-flop and inhibit the write capability of the drive. The Write Protect flip-flop is also set if the WR PROT indicator is off and the operator presses the WT PROT switch.

3.2.7 Write Data and Clock

BUS WT DATA & CLK L transmits multiplexed data and clock pulses to the disk drive.

3.2.8 Write Gate

BUS WT GATE L transmits a signal to simultaneously turn on both the write and erase current in the selected write head. The controller places a logical 1 on this line 1 μ s prior to transmitting the write data. This line remains at logical 1 throughout the data transmission time.

3.2.9 Restore (RTZ)

BUS RESTORE L transmits a signal to position the read/write heads at cylinder zero. The controller places a logical 1 on this line prior to issuing the Strobe (BUS STROBE L) signal. About 2 μ s after this signal is issued, the drive returns an Address Acknowledged signal, clears the address register, and moves the heads to cylinder zero. The Restore line remains at logical 1 until the Address Acknowledged signal is received by the controller.

3.2.10 Read Gate

BUS RD GATE L transmits a signal that allows data to be read from the drive. The controller places a logical 1 on this line to enable the Read Clock and Read Data output lines. This line remains at logical 1 throughout the entire read operation.

3.3 OUTPUT INTERFACE LINES

3.3.1 File Ready (Drive Ready)

BUS FILE RDY L transmits a logical 1 to indicate the following conditions:

1. Drive operating power is correct.
2. A disk cartridge is properly loaded.
3. The drive front door is closed.
4. RUN/LOAD switch is in the RUN position.
5. Spindle is rotating at the correct speed.
6. Read/write heads are loaded.
7. Write Check is false.

3.3.2 Read, Write, or Seek Ready/On Cylinder

BUS R/W/S RDY L transmits a logical 1 to indicate that the drive is in the File Ready condition and is not performing a seek operation.

3.3.3 Address Accepted

BUS ADDRESS ACCEPTED L transmits a 5- μ s negative pulse to indicate that the drive has accepted a Seek command with a valid address and the command execution has begun. The negative pulse is generated about 2 μ s after receipt of the Strobe signal, even if there is no change from the present address.

3.3.4 Address Invalid (Logic Address Interlock)

BUS LOG ADD INT L transmits a 5- μ s negative pulse to indicate that the drive has received a nonexecutable Seek command with a cylinder address greater than 202. For this case, the Seek command is suppressed in the drive and the heads are not moved. The pulse generation time is the same as for the Address Acknowledged signal.

3.3.5 Seek Incomplete

BUS SIN L transmits a logical 1 to indicate that some malfunction in the drive did not allow the seek operation to be completed. This line remains low until a Restore command is received or the operator sets the RUN/LOAD switch to LOAD and then back to RUN.

3.3.6 Write Protect Status

BUS WT PROT STATUS L transmits a logical 1 to indicate that the write capability of the drive is inhibited (write-protected). When this line is at logical 1, the WT PROT indicator on the drive control panel lights.

3.3.7 Write Check

BUS WT CHK L transmits a logical 1 to indicate the following conditions:

1. Erase or write current without a WRITE GATE.
2. Inoperative linear positioner transducer lamp.

When the Write Check signal is at a logical 1, all external commands to the drive are suppressed and the FAULT indicator on the drive control panel lights. If the fault condition is temporary, the operator may turn off the FAULT indicator by pressing the WT PROT switch. This action, however, causes the WT PROT indicator to light; the WT PROT switch must be pressed a second time to turn off the WT PROT indicator.

3.3.8 Read Data

BUS RD DATA transmits read data only (160-ns pulses).

3.3.9 Read Clock

BUS RD CLK L transmits read clock pulses only (160-ns pulses).

3.3.10 Sector Address (4 Lines)

BUS SEC CNTR 0 through 3 L indicate which sector is passing under the read/write heads. The sector address is a 4-bit binary code derived from the Sector Address counter.

3.3.11 Sector Pulse

BUS SEC PLS L transmits a 2- μ s negative pulse each time a sector slot passes the sector transducer. The index slot (unique slot) is suppressed in this line and is transmitted on a separate Index Pulse line.

3.3.12 Index Pulse

BUS INDX PLS L transmits a single 2- μ s negative pulse for each revolution of the disk. The Index Pulse occurs 600 μ s after the last sector pulse and is generated each time the index slot (unique slot) is detected by the sector transducer.

3.3.13 AC LOW

BUS AC LO L transmits a logical 1 when there is a loss (for more than 45 ms) of the 30 Vac within the drive. When AC LOW occurs, the drive finishes reading/writing the current sector, then initiates a normal head-retract and unload cycle. If a total power loss occurs before the heads are completely retracted, the safety relay is de-energized to retract the heads under battery power (emergency retract).

3.3.14 DC LOW

BUS DC LO L transmits a logical 1 when the ± 15 Vdc within the drive drops to 12 Vdc or below. When DC LOW is generated, the safety relay is de-energized to retract the heads under battery power (emergency retract). Since the RUN gate of each drive is connected to the DC LOW bus, a DC LOW signal from any one drive in a multidrive system disables all the drives in the system.

3.3.15 High Density/RK05 L

BUS RK05 L transmits a logical 1 (indicating high density only) whenever the drive is selected. (All RK05s are high density.)

CHAPTER 4

THEORY OF OPERATION

4.1 FUNCTIONAL DESCRIPTION

Figure 4-1 illustrates the major areas and associated signals of the RK05 Disk Drive. Together they rotate the recording disk, align the heads at a specified cylinder, and perform the read and write functions.

Paragraphs 4.1.1 through 4.1.5 describe the major operations of the disk drive; Paragraphs 4.2.1 through 4.5 describe the detailed logical sequence of each major operation.

4.1.1 Start

During the start cycle, the control and interlock logic controls the spindle motor operation. To energize the spindle motor, the RUN/LOAD switch must be in the RUN position and operating power must be applied. In the case of the RK05 and RK05-J, the drive front door must be closed and the disk cartridge must be properly installed.

If these interlock conditions are fulfilled, the spindle motor is energized. After an 8-second delay, to allow the spindle to accelerate to operating speed, the control and interlock logic generates an internal LOAD HEADS signal, which loads the read/write heads and positions them at cylinder zero (Paragraph 4.2.5.1). When the heads are loaded and positioned at cylinder zero, the RDY and ON CYL indicators light, and the BUS FILE RDY and R/W/S RDY/ON CYL interface lines go low.

Figure 4-2 illustrates the logical sequence during the start cycle. Paragraph 4.2.2 contains a detailed description of the preceding sequence.

4.1.2 Stop

The disk drive can enter a stop cycle in three ways:

1. Placing the RUN/LOAD switch to LOAD
2. Losing spindle speed
3. Losing operating power in any drive on the bus.

If any of the preceding conditions occur, the control and interlock logic removes the internal LOAD HEADS signal and brings the BUS FILE RDY interface line high. When LOAD HEADS is removed, the positioner control logic retracts the read/write heads. After the heads are fully retracted, the spindle motor is de-energized and the spindle coasts to a stop (about 30 seconds). When the spindle has stopped rotating, the LOAD indicator lights and, in the RK05 or RK05-J, the drive front door unlocks.

Figure 4-3 illustrates the logical sequence during the stop cycle. Paragraph 4.2.3 contains a detailed logic description of this sequence.

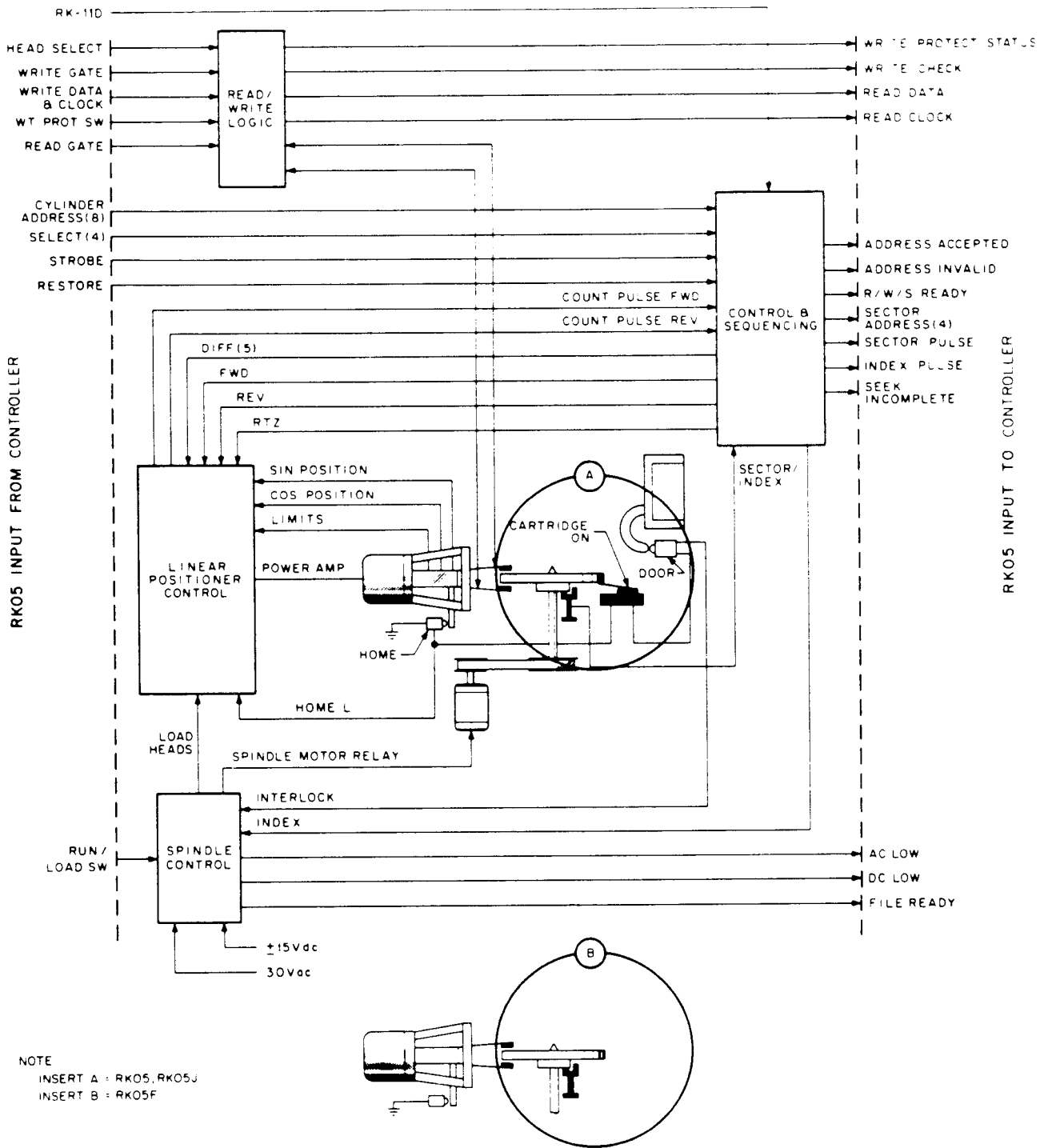
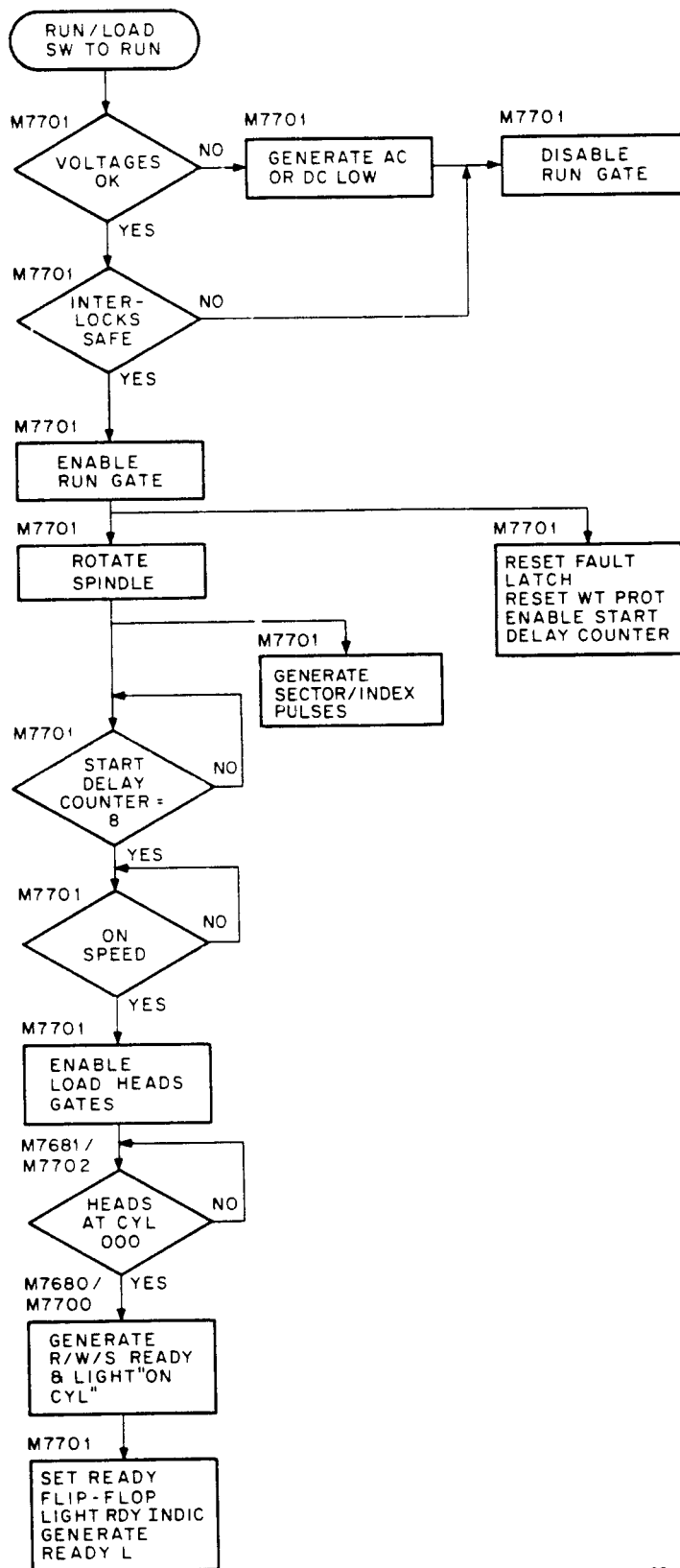
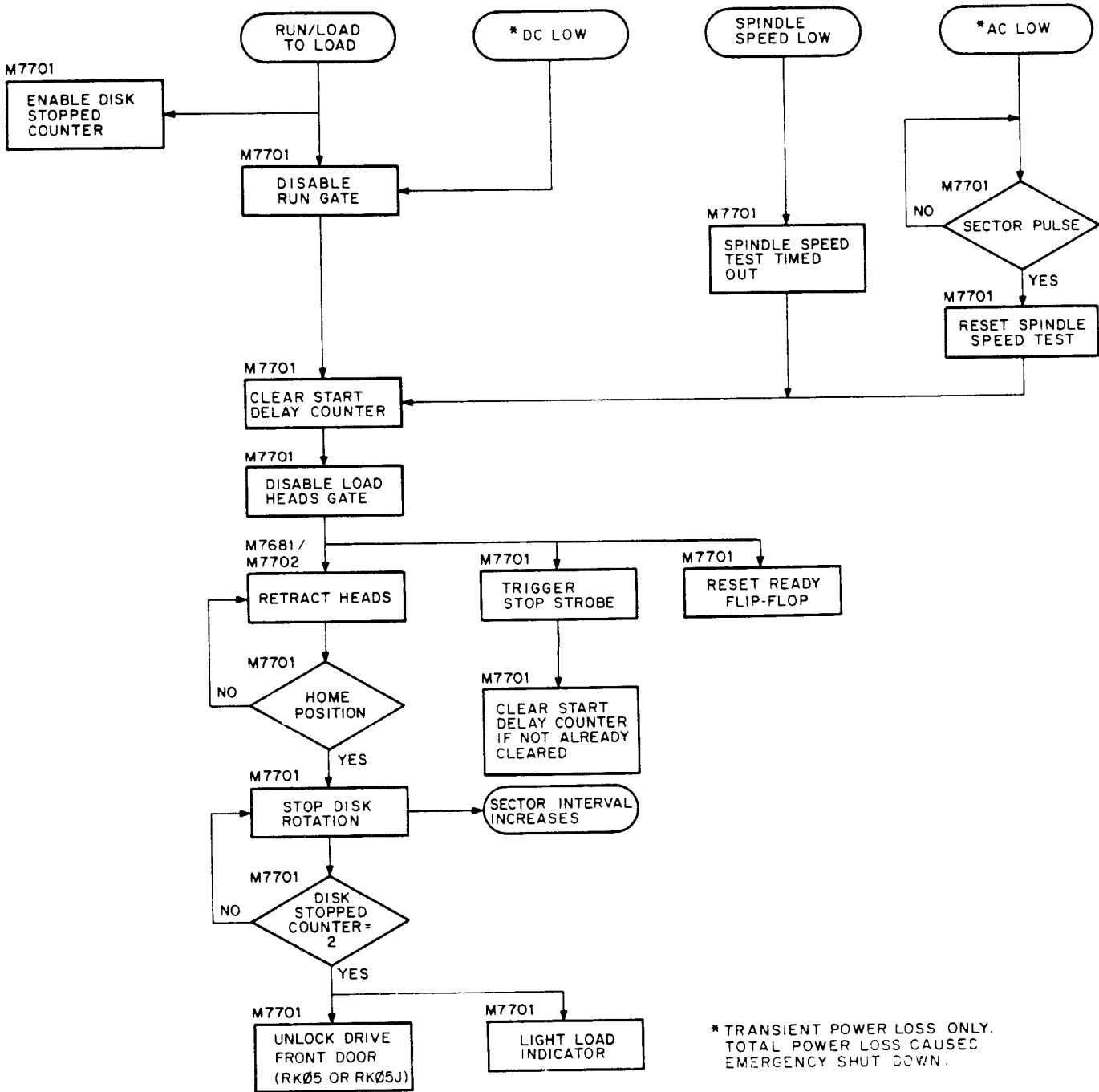

Figure 4-1 Functional Block Diagram



CP-0241

Figure 4-2 Start Flowchart



CP-0240

Figure 4-3 Stop Flowchart

4.1.3 Track Addressing and Head Positioning

To move the read/write heads from a current location to a new location above the disk (a seek operation), a selected drive must first receive an 8-bit binary cylinder address from the controller. If the new address exceeds cylinder 202, the BUS ADDRESS INVALID L (Logic Address Interlock) interface signal is generated and head motion is suppressed. If the new address does not exceed cylinder 202, the BUS ADDRESS ACCEPTED L interface signal is generated and the new address is compared to the current address. The comparison result (difference) is fed to a positioner servo system to move the heads.

As the heads pass each cylinder, output pulses from the linear positioner transducer trigger a Difference register to control the velocity of head motion (Paragraph 4.3). As the heads approach the destination cylinder, the head positioner decelerates, eventually stopping the heads at the designated cylinder. After a small delay, to allow the heads to settle at the new location, the ON CYL indicator on the control panel lights and the R/W/S READY interface line goes low.

If at any time during the seek operation a return-to-zero (Restore) command is received, or the heads reach the inner limit of the disk, the seek operation is immediately terminated and the heads are retracted to cylinder zero of the logical drive currently selected.

Figures 4-4 and 4-5 illustrate the logical sequence during a seek or return-to-zero operation. Paragraph 4.2.5 contains a detailed logic description of this sequence.

4.1.4 Recording Technique

Each head is a four-terminal, magnetic device containing two coils. A center-tapped coil performs the read or write function, while the other series-connected coil performs the erase function. The head (Figure 4-6) is designed so that the erase coil is electrically connected to the center tap of the read/write coil and is energized (Figure 4-7) whenever a write operation occurs. This head configuration, called "straddle erase," erases most of the residue from previous recording between the tracks and thus eliminates track "crosstalk" or interference from such recording. The RK05 and RK05-J data tracks are 0.007-inch wide with 0.003-inch erased separation bands. RK05-F data tracks are 0.004-inch wide with 0.001-inch erased separation bands. True center-to-center spacings are 0.010000-inch in the RK05 and RK05-J and 0.005053-inch in the RK05-F. During a write operation, current through the write coil automatically overwrites old data.

The RK05-type drives use a double-frequency, non-return-to-zero (NRZ) method of magnetic recording. In this method, flux reversals (clock pulses) are recorded on the magnetic disk at regularly-spaced intervals (Figure 4-8). The time period between these clock pulses is a bit cell, and data storage occurs within these cells. A flux reversal during a bit cell represents a logical 1; the absence of a flux reversal during a bit cell is a logical 0.

4.2 LOGICAL DESCRIPTION

4.2.1 Power ON/OFF Sequence

Application of ac power lights the PWR indicator, turns on the blower, and energizes the various voltage regulators. If ac power is removed when the read/write heads are not in the "home" position, the home microswitch applies battery power to the linear motor, retracting the heads to "home."

4.2.2 Start

Figure 4-9 is a block diagram illustrating the control and interlock aspects of the start/stop cycle. Although some logic elements are indicated, this figure is principally intended to simplify the actual gating and signal flow. If any gate-chasing or logic analysis is anticipated, refer to the M7701 circuit schematic.

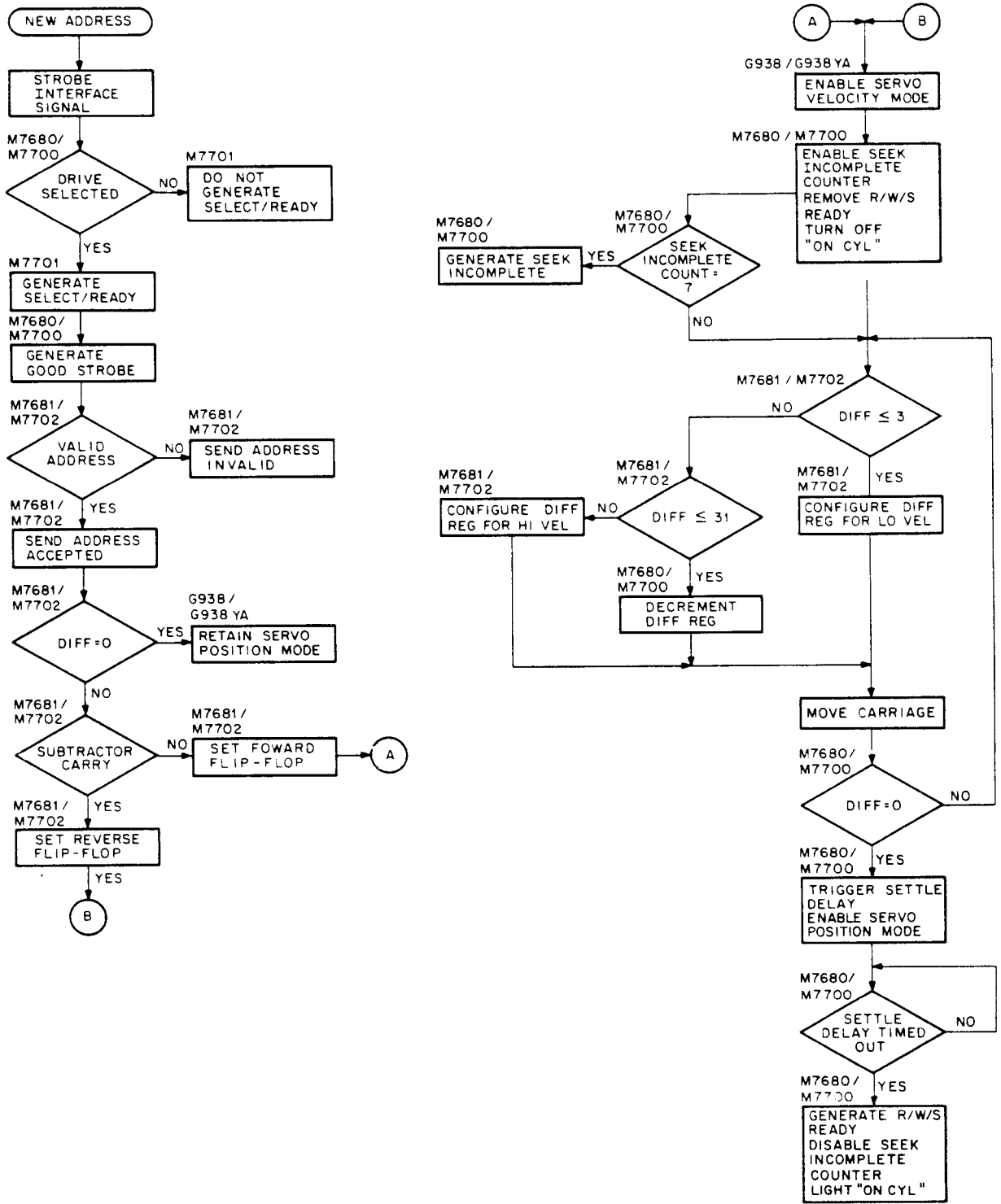

CP -0276

Figure 4-4 Seek Flowchart

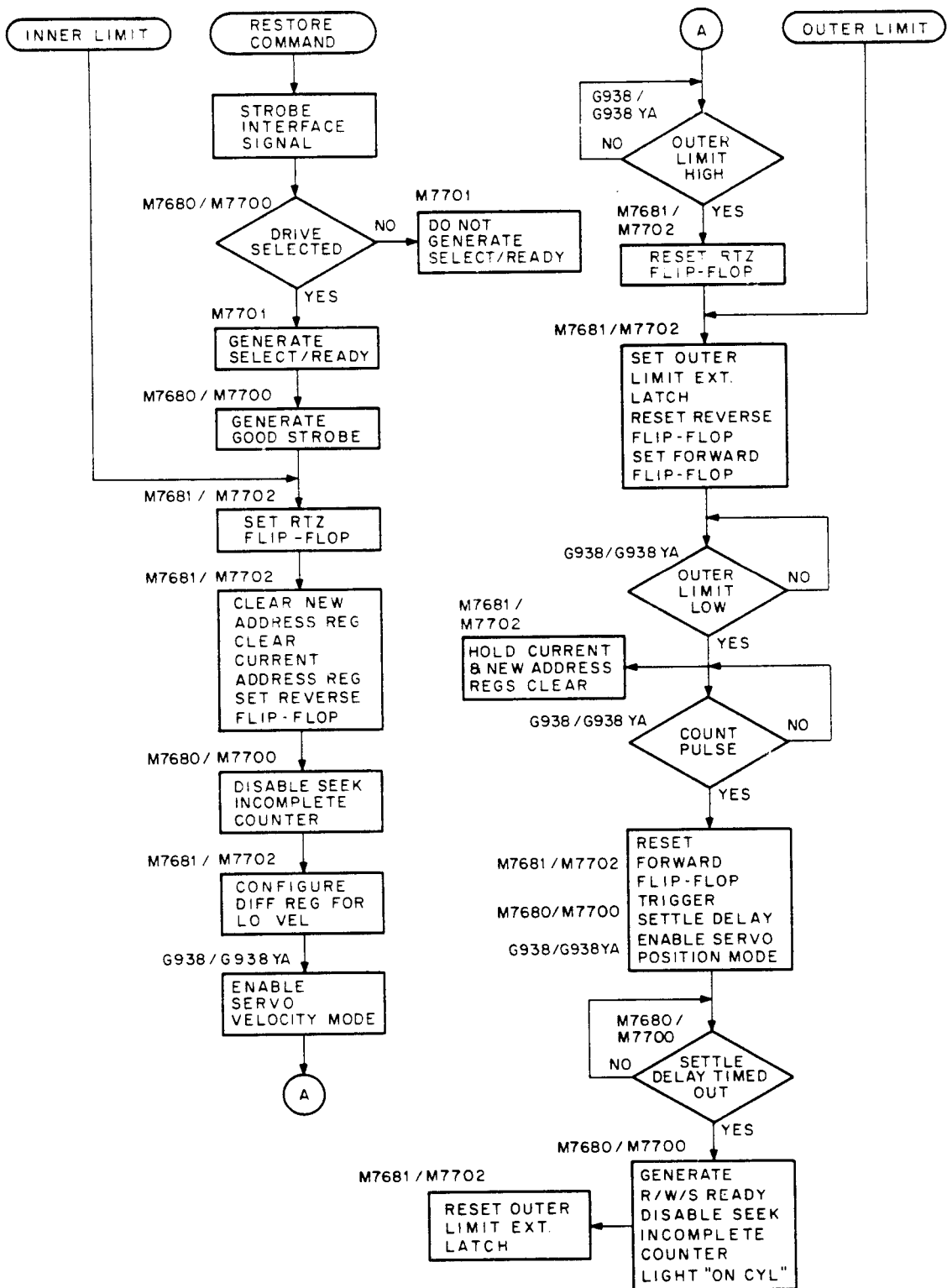

CP-0275

Figure 4-5 Return-to-Zero (Restore) Flowchart

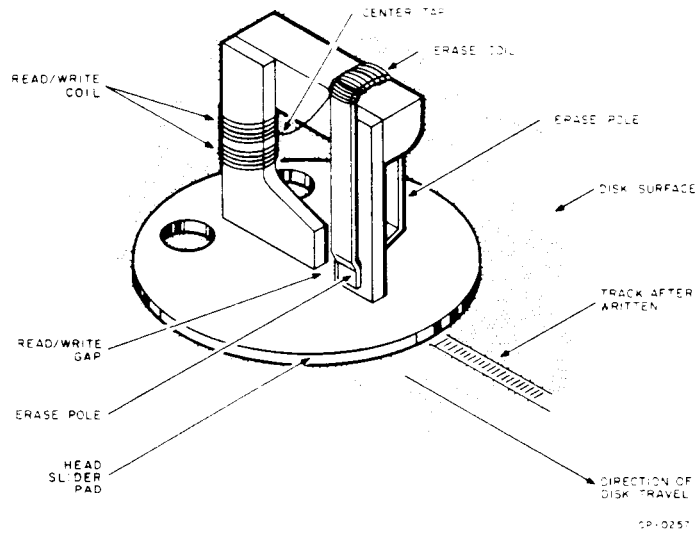

Figure 4-6 Read/Write Head

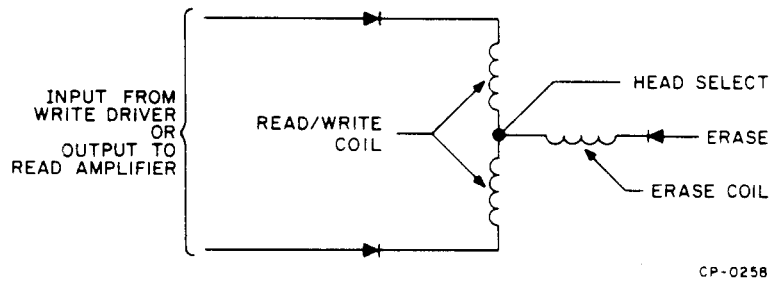
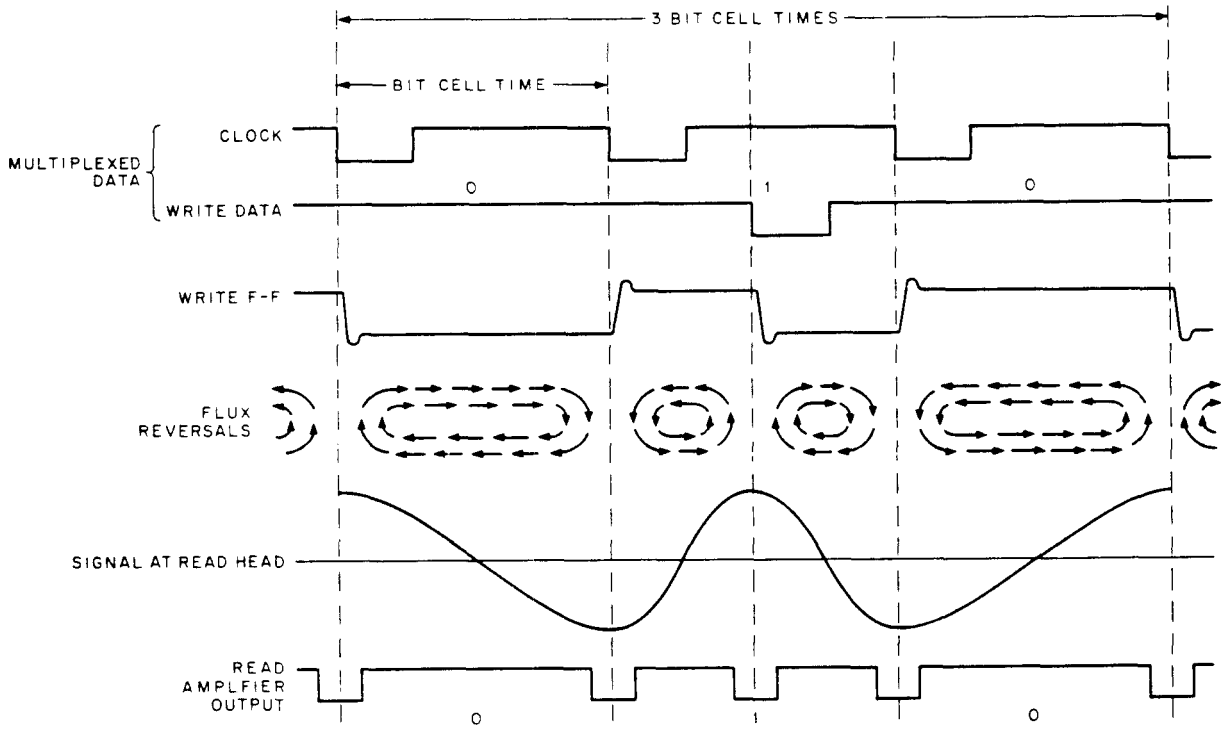

Figure 4-7 Simplified Read/Write Head Circuit



CP-0259

Figure 4-8 Double Frequency Pulse Relationship

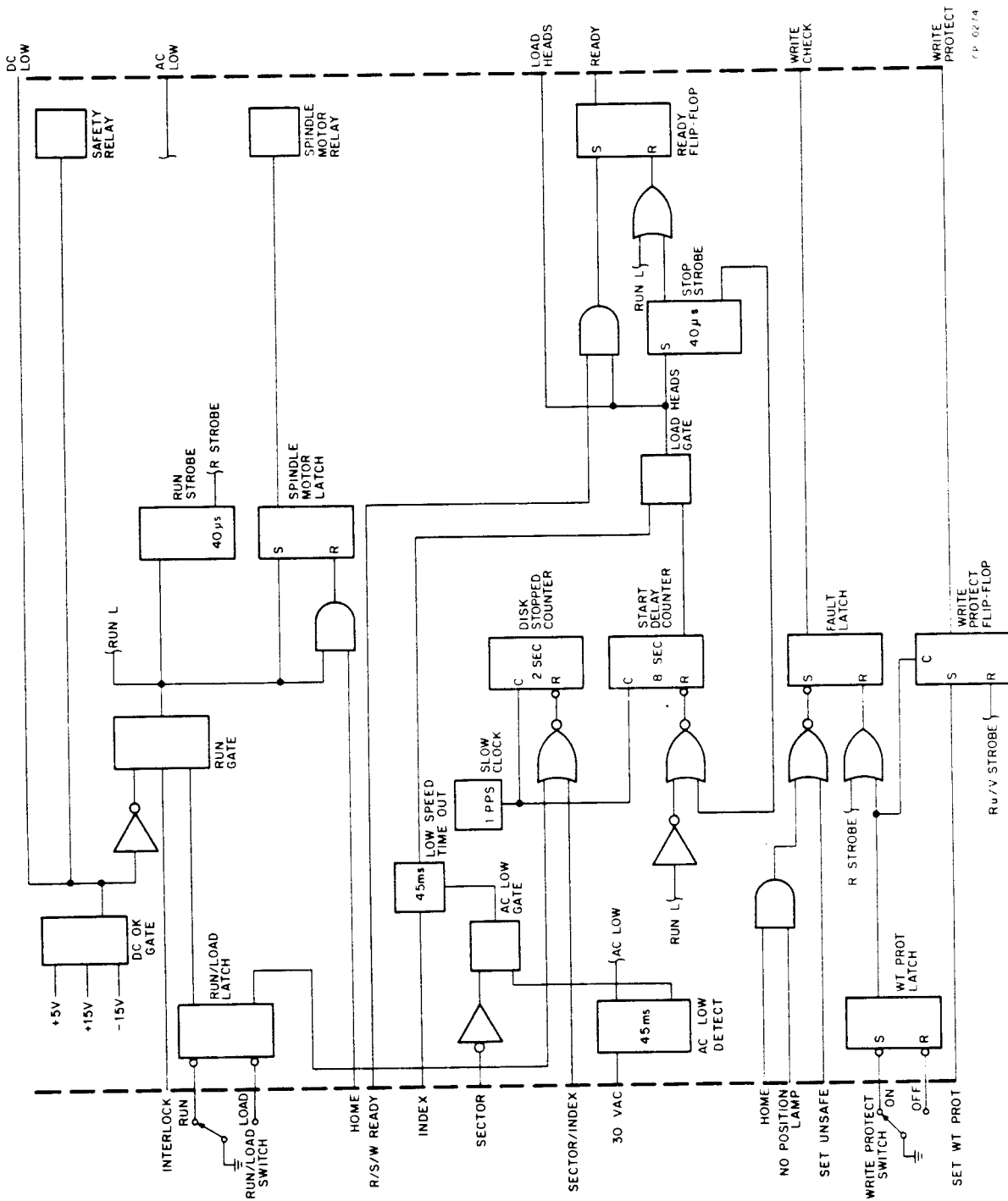

Figure 4-9 Control and Interlock Block Diagram

Placing the RUN/LOAD switch on the front control panel in the RUN position enables the Run gate, provided that the +15 and -15 Vdc are above 12 Vdc and the +5 Vdc is above 4.6 Vdc (Paragraph 4.2.3.4), and in the case of the RK05 and RK05-J, that a disk cartridge has been properly installed and the drive front door is closed and locked.

With the Run gate enabled, the spindle motor latch is set to energize the spindle motor relay and initiate disk rotation. At the same time, the Start Delay counter begins to count pulses (at a rate of one pulse per second) from the Slow Clock. When a count of eight (8 seconds) is reached, a feedback output from the counter prevents it from incrementing further. By this time, if the spindle has accelerated to the correct operational speed (Paragraph 4.2.3.2), the set output from the On Speed flip-flop is ANDed with the Start Delay counter output to enable the Load Heads gate and produce the LOAD HEADS signal. This signal enables the D input of the Ready flip-flop, and also allows the positioner to move the read/write heads to cylinder zero (Paragraph 4.2.5.1). Once the heads are positioned and settled at cylinder zero, the signal R/W/S READY is produced, lighting the ON CYL indicator (M7680/M7700) and clocking the Ready flip-flop set. When the Ready flip-flop sets, the BUS FILE RDY interface signal is produced and the RDY indicator on the control panel lights. The drive is then ready to perform a seek, read, or write operation.

4.2.3 Stop

The following paragraphs describe the ways that the disk drive can enter a stop cycle. Figure 4-9 illustrates some of the logic elements used in a start/stop cycle. These logic elements are located on the M7701 card.

4.2.3.1 Normal Stop - Placing the RUN/LOAD switch in the LOAD position enables the Disk Stopped counter and disables the Run gate, causing RUN L to come high. Once enabled, the Disk Stopped counter begins to increment; however, it is reset repetitively by every SECTOR/INDEX pulse before it reaches a count of two. This counter reset technique keeps the door unlocking solenoid de-energized in the case of the RK05 or RK05-J to prevent the operator from opening the drive front door before the disk has come to a complete halt.

RUN L high clears the Start Delay counter, disabling the Load Heads gate, thus removing the LOAD HEADS signal. Once cleared, the Start Delay counter must again increment to eight before the LOAD HEADS signal can be regenerated. This practice allows the heads to fully retract or unload before they can be loaded again. Removal of the LOAD HEADS signal resets the Ready flip-flop and also allows the positioner to retract the read/write heads (Paragraph 4.2.5.3). When the heads have fully retracted, the home microswitch closes to generate the HOME L signal. HOME L resets the Spindle Motor latch, de-energizing the spindle motor and allowing the spindle to coast to a stop.

As the spindle decelerates, SECTOR/INDEX pulses occur at a slower rate. Approximately 30 seconds after the Disk Stopped counter is enabled, the disk stops rotating, SECTOR/INDEX pulses cease, and the Disk Stopped counter is incremented by two pulses from the Slow Clock. When the counter reaches two (2 seconds from receipt of the last SECTOR/INDEX pulse), a feedback output from the counter prevents it from incrementing further, while the counter set output energizes the RK05 and RK05-J door-unlocking solenoid and lights the LOAD indicator on the control panel. The drive front door can now be opened and the cartridge removed.

4.2.3.2 Low Speed Stop – When the disk is rotating at normal speed (1500 rpm), INDEX pulses are generated every 40 ms to trigger the 41 – 49 ms Low Speed Time Out one-shot. The one-shot output is applied to an associated On Speed flip-flop. As long as the spindle rotation remains above an unsafe speed, successive INDEX pulses keep the On Speed flip-flop set, thus maintaining the LOAD HEADS signal. If the spindle speed drops below approximately 1200 rpm, the INDEX pulse interval increases beyond 50 ms. If this occurs, the Low Speed Time Out one-shot expires and resets the On Speed flip-flop. With the flip-flop reset, the LOAD HEADS signal is removed, causing the positioner to retract the read/write heads (Paragraph 4.2.5.3). When LOAD HEADS is removed, the 40 μ s Stop Strobe one-shot triggers, clearing the Start Delay counter. Once cleared, the Start Delay counter must again increment to eight before the LOAD HEADS signal can be regenerated. This practice allows the heads to fully retract (unload) before they can be loaded again.

The remainder of the low speed stop cycle is the same as a normal stop (Paragraph 4.2.3.1).

4.2.3.3 AC Low Stop – During normal operation, the 45-ms AC Low Detect one-shot is repeatedly triggered set by the presence of 30 Vac. If this voltage is removed for more than 45 ms, the AC Low Detect one-shot times out. With the one-shot reset, the AC LOW interface signal is generated. Following the AC LOW signal, the drive continues to operate until the next SECTOR pulse to reset the Low Speed Time Out one-shot. Thus, a data transfer in progress continues until the end of the sector before the interface signals are removed.

The remainder of the ac low stop cycle is the same as a low speed stop (Paragraph 4.2.3.2). However, if a total power loss occurs before the heads are completely retracted, the safety relay closes to retract the heads under battery power (emergency retract) and to maintain the AC LOW interface signal.

4.2.3.4 DC Low Stop – If the +15 or –15 Vdc drops below 12 Vdc, or if the +5 Vdc drops below +4.6 Vdc, the DC OK gate is disabled. The output from this gate immediately disables the Run gate, de-energizes the safety relay to retract the heads under battery power, and generates the BUS DC LOW interface signal.

4.2.4 Disk Drive Addressing

For greater flexibility in a multidrive system, a drive address assignment can be changed by changing the position of the Address Select Switch (S1) on the M7680/M7700 card. This switch operates in conjunction with the RK11-D interface line plus the address select decoding logic (M7680/M7700), as described in the following paragraphs.

4.2.4.1 RK11-D Address Selection – If the operating controller is an RK11-D, the interface signal BUS RK11-D L is present. This signal, applied through an inverter, enables a three-line-to-eight-line binary decoder and disables the linear input gates. Thus, when the binary-encoded (BUS SEL DR 0/A/E L through BUS SEL DR 2/C/H L) drive address is applied through the input gates to the binary decoder, the decoder translates the 3-bit binary code and activates one of the eight Address Select switch positions, or in the case of the RK05-F, one pair of positions. (The RK05-F side of the RK05-F/RK05-J select switch wires four pairs together; thus, selecting either position 0 or 1 selects both positions.) If the Address Select switch on the M7680/M7700 card has been set to this activated position, the signal SELECT H is produced. SELECT H, ANDed with the set output from the Ready flip-flop (M7701) and the reset output from the Fault latch, produces the signal SELECT/READY L. This signal allows the drive to perform the various control and read/write operations.

4.2.4.2 RK11-C or RK8/E Address Selection – If the operating controller is an RK11-C or RK8/E, the interface signal BUS RK11-D L is not present. Hence, the three-line-to-eight-line binary decoder is disabled and the linear input gates are enabled. This circuit configuration connects the BUS SEL DR lines, as a linear set, directly to positions 0 through 3 of the Address Select switch on the M7680/M7700 card. If that switch is set to one of the first four positions and the corresponding BUS SEL DR line is at a logical 1, the signal SELECT/READY L is produced, as described previously in

Paragraph 4.2.4.1, to select the drive associated with that line. In the case of the RK05-F, the drive may occupy positions 0 and 1 or 2 and 3; selection of either position occupied by a drive selects the drive.

4.2.5 Seek

4.2.5.1 Load Heads Seek – Placing the RUN/LOAD switch in the RUN position generates the signal LOAD HEADS L (Paragraph 4.2.2). Because the read/write heads are in the “home” position at this time, the signal OUTER LIMIT H (M7681/M7702) is present. This signal is ANDed with the inverted LOAD HEADS L signal to set the Forward and reset the Reverse flip-flops. In addition, OUTER LIMIT H sets the Outer Limit Extender latch to hold the New and Current Address registers at 0.

In the RK05 and RK05-J Disk Drives, the Q outputs from the New Address register and the Q outputs from the Current Address register are applied to the subtractor. Use of the Q outputs from the New Address register effectively complements the new address, allowing a 1’s complement addition to take place in the subtractor. During this addition, the second stage of the subtractor performs an end-around carry operation. Because the Current Address register and the New Address register are both cleared, the remainder from the 1’s complement addition is zero; thus, a no-carry condition is produced. The binary 0 from the subtractor is then applied, through exclusive OR circuits and the “> 3” decoding gate, to set the Difference register to a low-velocity binary output.

NOTE

Low velocity is when all stages of the Difference register are set. High velocity is when all stages are cleared.

When the Forward flip-flop sets, FWD H and MOVE L are generated. FWD H is applied to the servo logic to place it in the velocity mode (Paragraph 4.3.1.1) and initiate forward head motion.

As the heads begin to move at low velocity toward cylinder zero, count pulses are generated by the positioner transducer (Paragraph 4.3.1). When the heads pass the outer limit of the recording disk, OUTER LIMIT H goes low, applying a low to the D input of the Forward flip-flop. As the heads approach cylinder zero, COUNT PULSE REV H (first count pulse after OUTER LIMIT H goes low) resets the Forward flip-flop. This action removes FWD H and MOVE L, and places the servo logic in the detent mode (Paragraph 4.3.1.2).

MOVE L high triggers the 6-ms Positioner Settle Delay one-shot (M7680/M7700). When this one-shot times out, the R/W/S Ready flip-flop sets to disable the Seek Incomplete counter, light the ON CYL indicator, and generate the BUS R/W/S RDY L signal. BUS R/W/S RDY H resets the Outer Limit Extender latch.

4.2.5.2 Forward Seek – To move the read/write heads closer to the disk spindle (forward seek), the controller places an 8-bit binary address on the Cylinder Address interface lines (BUS CYL ADD 0 through 7), transmits a STROBE pulse, and simultaneously addresses the disk drive (Paragraph 4.2.4). Reception of the STROBE pulse (M7680/M7700) generates the GOOD STROBE L pulse to clock the cylinder address from the interface lines (M7681/M7702) into the New Address register.

The Q outputs from the New Address register are applied to both the subtractor and the Invalid Address Detector. Use of the Q outputs of the New Address register effectively complements the new address and thus allows a 1’s complement addition to take place in the subtractor. During this addition, the second stage of the subtractor performs an end-around carry operation.

If the New Address register output is greater than 202, the BUS ADDRESS INVALID signal is generated. If this is the case, the BUS ADDRESS ACCEPTED L signal remains high, keeping the Forward or Reverse flip-flops reset and preventing the Difference register from changing states.

If the New Address register output is equal to or less than 202, BUS ADDRESS INVALID L remains high. This signal is ANDed with the output of the Strobe Generator one-shot (M7680/M7700) to produce the BUS ADDRESS ACCEPTED L signal.

Simultaneously, the complemented New Address register output is added in the subtractor to the output of the Current Address register. If after this addition process a carry condition has not occurred, the positioner must either move the heads forward (toward the disk spindle) or retain the heads at their current location. To determine this fact, the subtractor carry output is inverted by the exclusive-OR circuits for only a no-carry condition. If the heads are to move forward, the high output from the "not zero" decoding gate is ANDed with the inverted carry output and applied to the D input of the Forward flip-flop.

When BUS ADDRESS ACCEPTED L goes low, the Forward flip-flop clocks, generating MOVE L and FWD H. FWD H is applied to the servo logic to place it in the velocity mode (Paragraph 4.3.1.1) and initiate forward head motion. MOVE L resets the R/W/S Ready flip-flop (M7680/M7700) to accomplish the following:

1. Enable the Seek Incomplete counter.
2. Remove the BUS R/W/S READY/ON CYL L interface signal.
3. Turn off the SEEK DONE/ON CYL indicator.

Once enabled, the Seek Incomplete counter begins to count INDEX pulses (40 ms repetition rate). If the counter reaches a count of seven (seek incomplete condition), the Seek Incomplete latch is set to generate the BUS SEEK INCOMPLETE L interface signal. If this occurs, the controller must issue a return-to-zero (Restore) command, or the operator must set the RUN/LOAD switch to LOAD and then back to RUN to continue normal operation.

If a seek incomplete has not occurred, and the distance from the present to the destination cylinder is greater than 31 for the RK05 or RK05-J, or 63 for the RK05-F, an output from the ≥ 32 (or ≥ 64 , if an RK05-F) decoding gate clears the Difference register (M7681/M7702) to a high-velocity binary output. This binary output is applied to the servo logic to move the heads forward at high velocity.

NOTE

High velocity is when all stages of the Difference register are cleared. Low velocity is when all stages are set.

As the read/write heads move across each track, output pulses (COUNT PULSE FWD H) derived from the positioner transducer are generated. As long as the Reverse flip-flop remains reset, each COUNT PULSE FWD H clocks the Forward flip-flop set and increments the Current Address register. Each time this register increments, the previously described addition process is repeated in the subtractor.

When the heads are 31 (RK05/RK05-J) or 63 (RK05-F) cylinders from the destination cylinder, the ≥ 32 or ≥ 64 decoding gate is disabled, permitting the Difference register to be decremented directly by the decoded output of the subtractor. When the heads are 3 (RK05/RK05-J) or 7 (RK05-F) cylinders from the destination cylinder, the ≤ 3 or ≤ 7 decoding gate is enabled to set the Difference register to a low-velocity binary output. The Current Address register continues to increment until the heads are within one-half cylinder of the destination cylinder. At this point, the "not zero" decoding gates is disabled and the Forward flip-flop is reset, thus removing FWD H and MOVE L.

FWD H low places the servo logic in the detent mode (Paragraph 4.3.1.2), while MOVE L high triggers the 6-ms Positioner Settle Delay one-shot (M7680/M7700). When this one-shot times out, the R/W/S Ready flip-flop sets to disable the Seek Incomplete counter, light the SEEK DONE/ON CYL indicator, and generate the BUS R/W/S READY/L interface signal. The drive is now ready to perform a read, write, or another seek operation.

4.2.5.3 Reverse Seek – A reverse seek is similar to a forward seek (Paragraph 4.2.5.2); however, if the current and new addresses are not alike, the subtractor (M7681/M7702) addition operation always results in a carry condition. Because of this fact, the “not zero” decoding gate is not used during this operation. The carry output from the subtractor sets the Reverse flip-flop to allow the Current Address register to decrement.

NOTE

Because of unique timing considerations during the reverse seek, inverted count pulses are used to decrement the Current Address register.

If during the initial power-on cycle, the heads are not fully retracted (unloaded), the “home” microswitch at the rear of the positioner is not depressed and the HOME L signal is high. HOME L is ANDed with LOAD HEADS L (high, because the RUN/LOAD switch is in the RUN position) to generate REV H and MOVE L. Simultaneously, LOAD HEADS L sets the Difference register to a low-velocity binary output, thereby retracting the heads at low speed to the home position. At this position, the carriage contacts the home microswitch, causing the HOME L signal to go low and thus remove REV H and MOVE L.

The heads would not normally be over the disk during the initial power-on cycle. Thus, this operation ensures that the positioner will not move forward until the drive is placed in the run mode.

4.2.5.4 Return-to-Zero (Restore) Seek – To return the read/write heads to cylinder zero, the controller generates a BUS RESTORE L signal, transmits a Strobe pulse, and addresses the disk drive (Paragraph 4.2.4). Reception of the Strobe pulse (M7680/M7700) generates the GOOD STROBE H pulse. This pulse, ANDed with BUS RESTORE H, resets the Seek Incomplete latch to remove the BUS SEEK INCOMPLETE L interface signal. BUS RESTORE H also sets the RTZ flip-flop (M7681/M7702) to accomplish the following:

1. Clear the New Address register.
2. Clear the Current Address register.
3. Set the Reverse flip-flop.
4. Produce the RTZ L signal.

RTZ L resets the Seek Incomplete counter and prevents it from incrementing.

When the Reverse flip-flop sets, REV H and MOVE L are generated. REV H is applied to the servo logic to place it in the velocity mode and initiate reverse head motion (Paragraph 4.3.1.1). MOVE L resets the R/W/S Ready flip-flop (M7680/M7700) to accomplish the following:

1. Reset the RTZ flip-flop.
2. Set the Outer Limit Extender latch, which holds the New and Current registers at zero.
3. Reset the Reverse and set the Forward flip-flops.

When the Forward flip-flop sets, the heads begin to return toward cylinder zero. Just before the heads reach cylinder zero, OUTER LIMIT H goes low. The next output pulse (COUNT PULSE REV H) from the positioner transducer (Paragraph 4.3.2.1) resets the Forward flip-flop and thus removes FWD H and MOVE L.

FWD H low places the servo logic in the detent mode (Paragraph 4.3.1.2), while MOVE L high triggers the 6-ms Positioner Settle Delay one-shot (M7680/M7700). When the one-shot times out, the R/W/S Ready flip-flop sets to disable the Seek Incomplete counter, light the ON CYL indicator, and generate the BUS R/W/S READY L interface signal. R/W/S READY H also comes high at this time to clear the Outer Limit Extender latch.

If, at any time during normal operation, the read/write heads reach the inner limit of the recording disk, INNER LIMIT H (M7681/M7702) goes high and sets the RTZ and Seek Incomplete flip-flops to initiate a return-to-zero seek automatically.

4.2.6 Sector/Index Pulse Generation

To read or record data with specific formats (e.g., data blocks) as well as to retrieve or store data at designated areas (sectors) on the disk, a timing scheme related to the rotational position of the disk is required. The SECTOR and INDEX pulses are used to accomplish this. These pulses are generated by slots in the recording disk hub that pass through a groove in the sector transducer. There are 12 equally spaced sector slots (16 slots for an RK8/E), which designate the 12 or 16 sectors on the disk. There is also one uniquely spaced index slot on the disk to indicate the last sector (one complete revolution). The sector transducer, located directly in front of the spindle, is an optical device that contains a light-emitting diode and a photosensor. As the recording disk rotates, the slots on the disk pass between the light-emitting diode and the sensor, producing negative SECTOR/INDEX pulses (Figure 4-10). Because both the SECTOR and INDEX pulses are produced from a single transducer, logic elements on the M7680/M7700 are used to separate these two pulses and to encode the sector address.

During disk rotation, SECTOR/INDEX pulses from the disk trigger the Sector Timing Delay one-shot. The pulse width of this one-shot can be adjusted to compensate for different sector transducer locations within various disk drives. Thus, when disk cartridges are interchanged, each data record is properly located with respect to the associated SECTOR pulse. The trailing edge from the Sector Timing one-shot triggers the Index/Sector one-shot to generate a 1- μ s INDEX/SECTOR L pulse. The trailing edge of this pulse in turn triggers the 1-ms Index Separator one-shot. The output signals from this one-shot are applied to decoding gates to separate the SECTOR pulses from the INDEX pulse. If another slot has not passed the transducer, the SECTOR L signal is produced and the 4-stage Sector Address counter is incremented. This sequence of events is repeated for every sector on the disk hub.

The occurrence of the last SECTOR pulse triggers the Index/Sector one-shot as before; however, 600 μ s later the INDEX pulse from the disk hub retriggers this one-shot. The set output from this one-shot is then ANDed with the set output from the Index Separator one-shot (still high from the previous triggering) to generate the INDEX PULSE L signal and to set the Counter Reset flip-flop. The leading edge of the next SECTOR pulse (sector 00) clears the Sector Address counter, and the trailing edge of this pulse resets the Counter Reset flip-flop. Thus, for every revolution of the disk, the counter is cleared to maintain the correct counter-to-disk relationship.

4.3 CARRIAGE POSITIONING

4.3.1 Positioner Servo Description

The positioner servo system (G938/G938YA) controls the carriage movement. There are two control loops within this system. A velocity loop controls the carriage velocity during a seek operation (velocity mode) and a position loop electronically detents the heads at a fixed cylinder location when a seek operation is not being performed (detent mode). During the velocity mode, velocity and direction commands are obtained from the cylinder address and difference logic (Paragraph 4.2.5). During the detent mode, velocity and position feedback signals are derived from the linear positioner transducer (Paragraph 4.3.2.1).

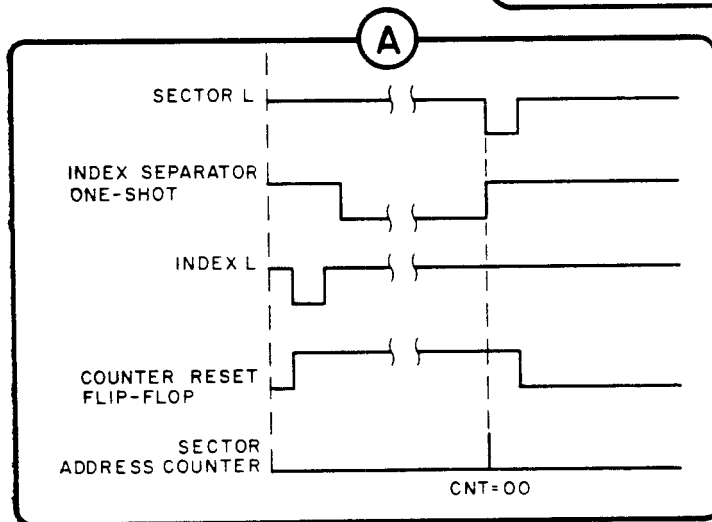
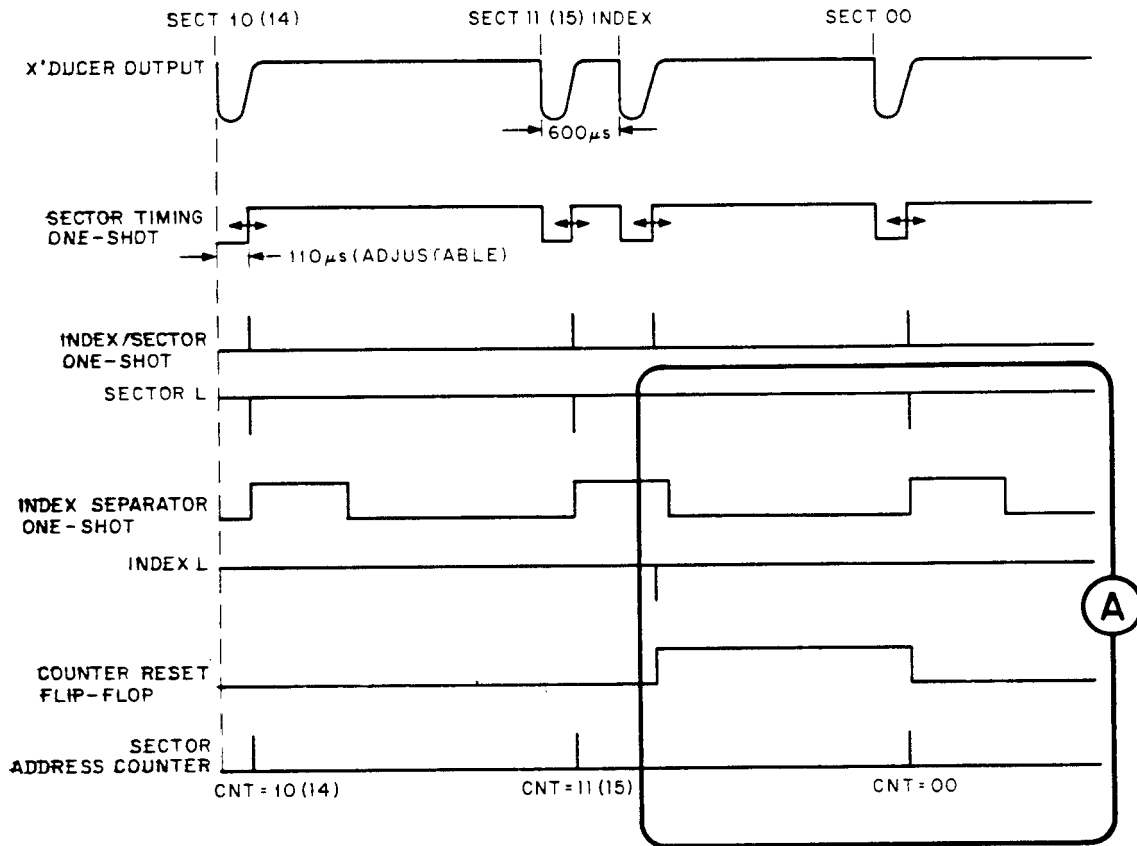

NOTE: THE NUMBERS IN PARENTHESIS ARE FOR AN RKB/E SYSTEM.

CP-0261

Figure 4-10 Sector/Index Timing

The servo system (Figure 4-11) is composed of the following functional areas.

- A linear positioner transducer that produces two sinusoidal signals. During the velocity mode, these signals are used to control the rate of carriage movement. During the detent mode, only one of these signals is used to electronically detent the carriage. In addition, the transducer also generates two limit signals that indicate the extremities of carriage travel.
- A velocity function generator that converts the digital difference signal into corresponding analog velocity commands.
- A velocity synthesizer that generates a feedback control signal from the transducer output.

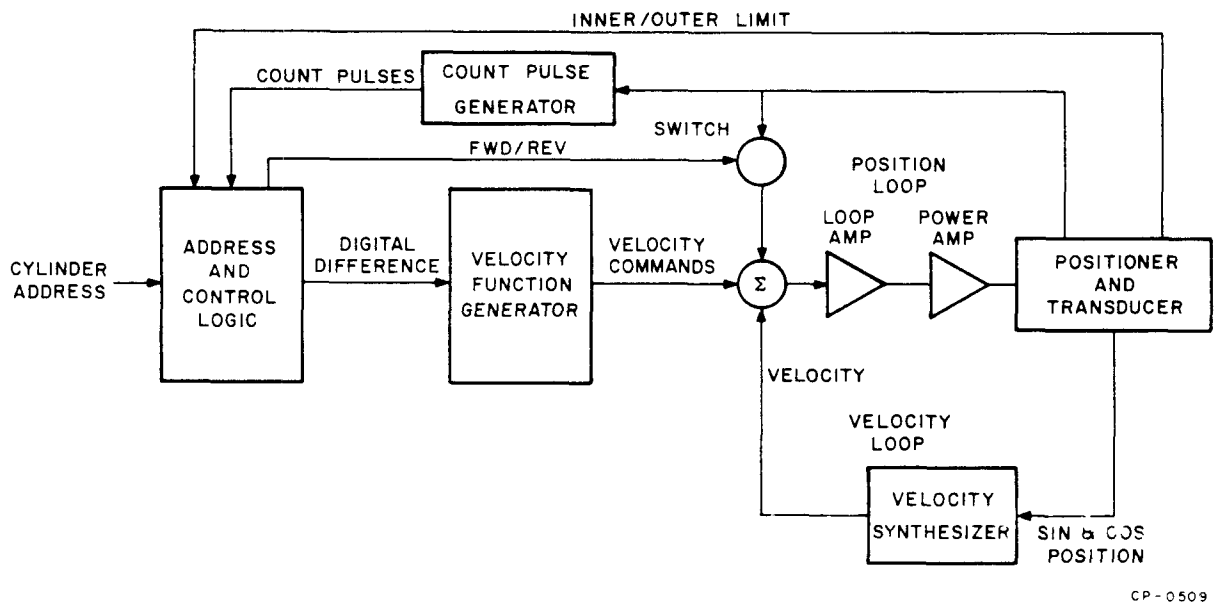

Figure 4-11 Servo System Block Diagram

4.3.1.1 Velocity Mode – During a seek operation, the cylinder address and difference logic computes the digital difference between the present cylinder address and the destination cylinder (Paragraph 4.2.5). This digital difference is then converted, by the D/A velocity function generator of the analog, to an analog velocity command. The amplitude of the analog signal depends upon the distance to the destination cylinder. If the distance is greater than 31 cylinders (or 63 cylinders, in the case of an RK05-F), a maximum velocity command is produced and applied to the velocity control loop. As the carriage accelerates, a feedback velocity signal is generated by the velocity synthesizer. When a speed of 35 ips is attained, this feedback signal inhibits further acceleration and maintains a constant 35 ips carriage speed until the heads are 31 (or 63) cylinders from the destination cylinder. From this point, the carriage decelerates at a controlled rate that is governed by the decrementing digital difference applied to the function generator.

When the heads are 3 cylinders (7 cylinders in the case of an RK05-F) away from the destination cylinder, the velocity generator produces a fixed low-velocity command that continues to move the carriage at low velocity (about 3 ips) until the heads are approximately one-half cylinder from the destination cylinder. At this point, the low velocity command is removed; however, the velocity signal remains to damp the carriage movement and prevent overshoot. Once the destination cylinder is reached, the position loop electronically detents the carriage.

4.3.1.2 Detent Mode – The detent mode of operation electronically retains the read/write heads at a desired cylinder with a force greater than 2000 pounds per inch. During this operational mode, the velocity command from the function generator is zero, allowing the small velocity feedback signal to produce a stable position loop. If the heads tend to deviate from the desired cylinder, an error correction signal (SIN POSITION), which is opposite in polarity from the direction of deviation, is generated by the positioner transducer. This error signal is then directly applied through the loop amplifiers to move the carriage back to the desired cylinder.

4.3.2 Servo Circuit Description

4.3.2.1 Linear Positioner Transducer – The positioner transducer (Figure 4-12), located on the underside of the carriage, is an optical device that consists of two parts. The stationary portion (reticle) of the transducer is constructed in a U shape and is attached to the carriage slide. One side of the U contains a lamp; the other side contains a stationary reticle with minute diagonal transparent slots, plus six photosensors located behind the slots. The movable portion (scale) of the transducer contains a similar section of minute vertical transparent slots and is attached to the movable carriage. As the scale moves in the middle of the U-shaped reticle, the vertical and diagonal slots allow varying light patterns to shine onto the photosensors. This action produces two sine wave output signals that occur 90 degrees out of phase. These signals (SIN POSITION and COS POSITION) are used to control the movement of the carriage.

Two dc signals (INNER LIMIT and OUTER LIMIT) are also generated by the transducer. As long as the scale travel remains within the slotted section (cylinder 0 through 202), neither one of these signals is produced; however, when the scale reaches the inner travel extremity ($>$ cylinder 202 for RK05, RK05-J, and the odd drives of RK05-F), the inner limit photosensor is uncovered and the negative INNER LIMIT signal is produced. The positive OUTER LIMIT signal is produced in a similar manner at the outer travel extremity ($<$ cylinder 0 for RK05, RK05-J, and the even drive of RK05-F).

4.3.2.2 Velocity Function Generator – The velocity function generator (Figure 4-13) is a 5-bit D/A converter. The generator logic elements are located on the G938/G938YA card. The 5-bit digital input to this logic component is derived from the five low-order difference bits from the cylinder address and difference logic. During a seek operation, these five bits represent the distance from the present cylinder address to the destination cylinder (Paragraph 4.2.5). If this distance is greater than 31 in the RK05/RK05-J or 63 in the RK05-F, all 5 input bits are low, producing a maximum amplitude output signal (velocity command). If the travel distance is less than or equal to 3 for the RK05/RK05-J or 7 for the RK05-F, all 5 inputs are high, producing a minimum velocity command. For differences between 4 and 30 for the RK05/RK05-J or between 8 and 62 for the RK05-F, the velocity command is proportional to the 5-bit binary representation. The velocity command is connected by Field Effect Transistors (FETS) to the summing node of the loop amplifier. To initiate carriage motion, the FWD or REV signal turns on the appropriate FET, thereby applying the velocity and direction command to the loop amplifier.

4.3.2.3 Velocity Synthesizer – In a closed-loop servo system, a speed-sensing feedback control signal is required to prevent uncontrolled velocity within the system. In the drives that comprise the RK05 family, this control or tachometer signal is electronically derived in the velocity synthesizer. These elements are located on the G938/G938YA card.

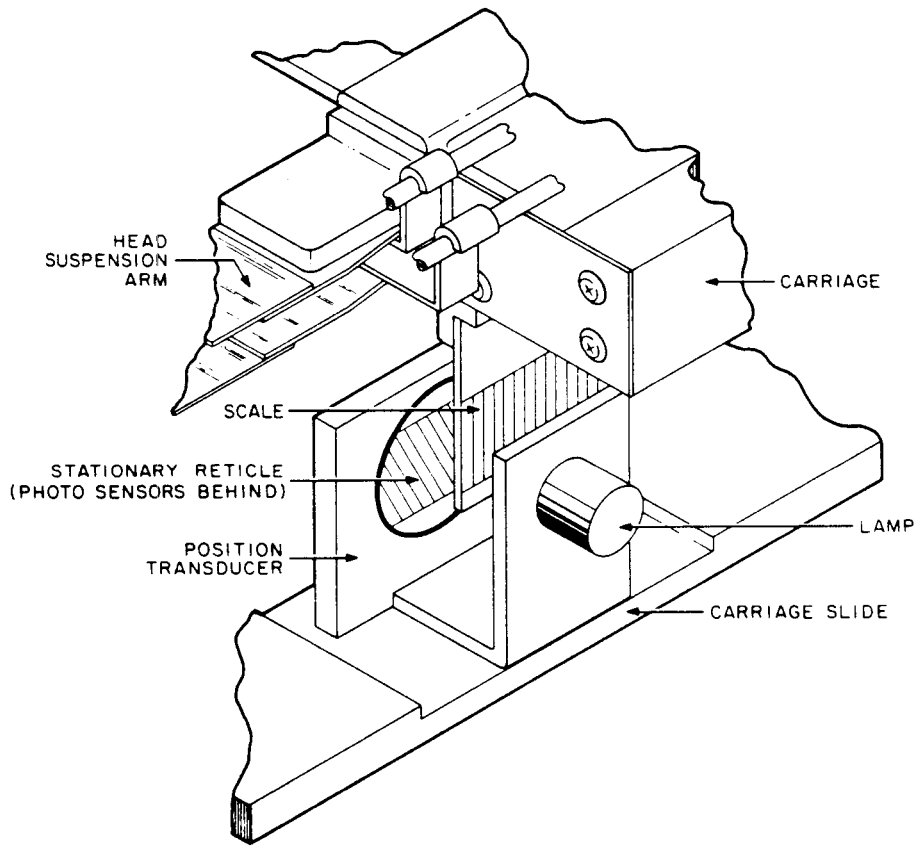

CP-0262

Figure 4-12 Linear Positioner Transducer

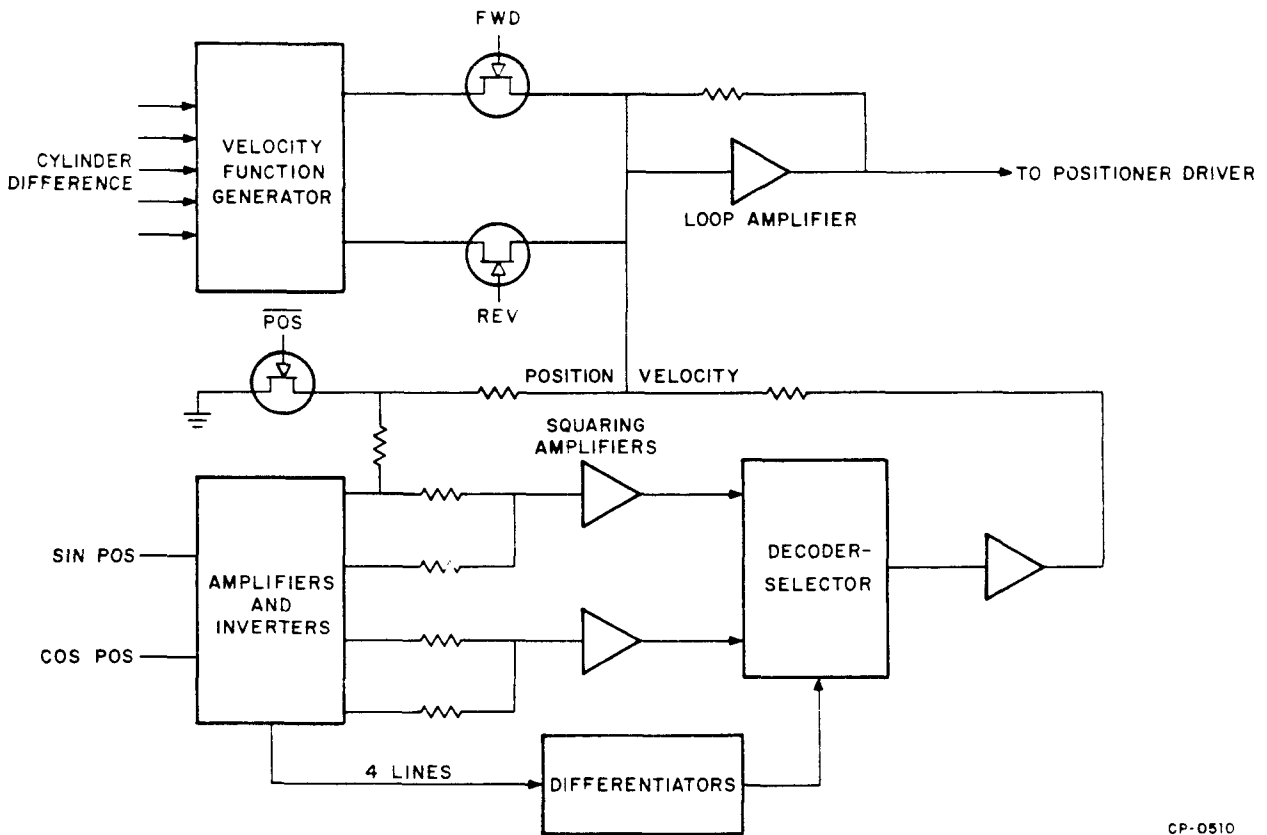

CP-0510

Figure 4-13 Simplified Positioner Servo Logic

During a seek operation, the SIN POSITION and COS POSITION signals from the positioner transducer are applied to amplifiers and unity gain inverters to provide four phases of position signal at the input of the synthesizer. The inverter/amplifier outputs are also applied to four differentiator networks. Appropriate pairs of amplifier/inverter outputs are applied to the summing junctions of two squaring amplifiers. The resultant square wave signals are displaced 90 degrees from each other and when these signals are gated together in the decoder/selector, they produce four separate selection signals of 90-degree duration. Each selection signal is centered around the peak of the corresponding differentiated signal. The derivative signals are then selectively summed in an operational amplifier to produce the velocity feedback signal. This signal is then applied, through a gain-setting resistor, to the summing node of the loop amplifier. Here, the velocity command from the velocity function generator is summed with the velocity feedback signal to produce a velocity profile signal (Figure 4-14 reflects the velocity profile for the RK05/RK05-J). Thus, for a 202-cylinder seek (full carriage stroke in the RK05/RK05-J), a maximum velocity profile is produced. The dotted lines in Figure 4-14 represent the initial portions of shorter seeks; however, the terminating portion of all seeks remains the same.

During the detent mode of operation, the POS signal turns on an FET that applies the SIN POSITION signal directly to the summing node of the loop amplifiers. This circuit configuration retains the heads at the desired cylinder location.

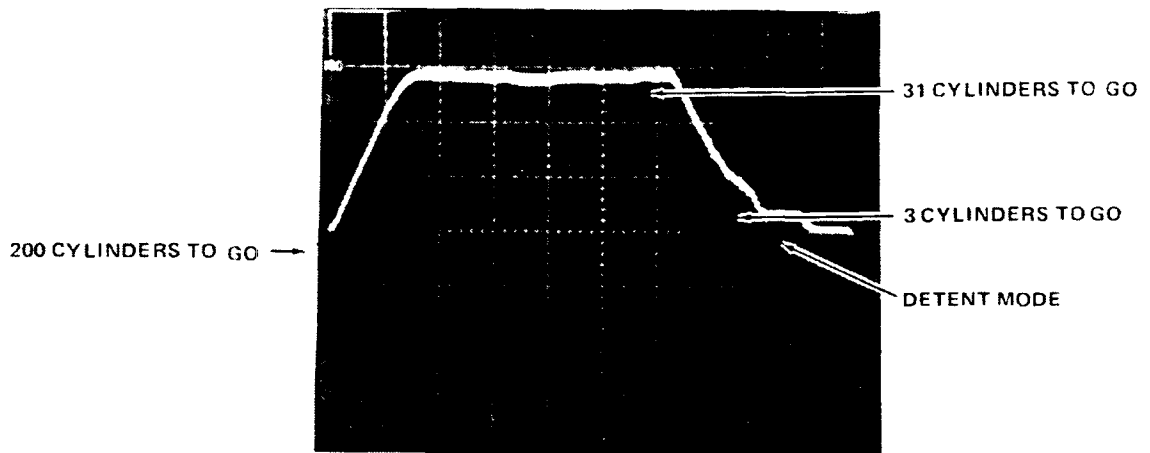

Figure 4-14 Velocity Profile (RK05/RK05-J)

4.4 READ/WRITE

All the circuit elements required for head selection, level changing, and waveform shaping during a read/write operation are on the G180 card, which is located in the first position of the electronic module. The read/write head connectors are directly attached, through an opening in the side of the electronic module, to connector pins on this card.

4.4.1 Read Operation

During a read operation, the selected read/write head detects flux reversals from a recorded data track on the rotating disk. Each flux reversal generates a small voltage peak, whose polarity corresponds to the direction of the flux reversal. The read waveform is then amplified, filtered to remove high-frequency noise components, and applied to wave-shaping circuits. These circuits convert each voltage peak to 160-ns logic level pulses and apply this pulse train to the data separator circuits (Figure 4-15). In the separator, the individual data and clock pulses are separated according to the double-frequency recording scheme (Paragraph 4.1.4). The data separator also contains frequency tracking and peak-shift compensating circuits.

Figure 4-16 shows the time relationship and the waveforms for a read operation. The letters in parentheses () in the following text correspond to the lettered waveforms in the figure.

To initiate a read operation, the controller:

1. Addresses a particular drive (Paragraph 4.2.4).
2. Positions the read/write heads at the appropriate cylinder (Paragraph 4.2.5).
3. Selects either the upper or lower read/write head (Paragraph 3.2.5).

For example, if the lower read/write head is to be used, the signal HD SELECT (G180-0-1) is high. This signal is ANDed with UNSAFE L (high, if no fault condition exists, Paragraph 4.5) to apply a ground potential to the center tap of the lower head.

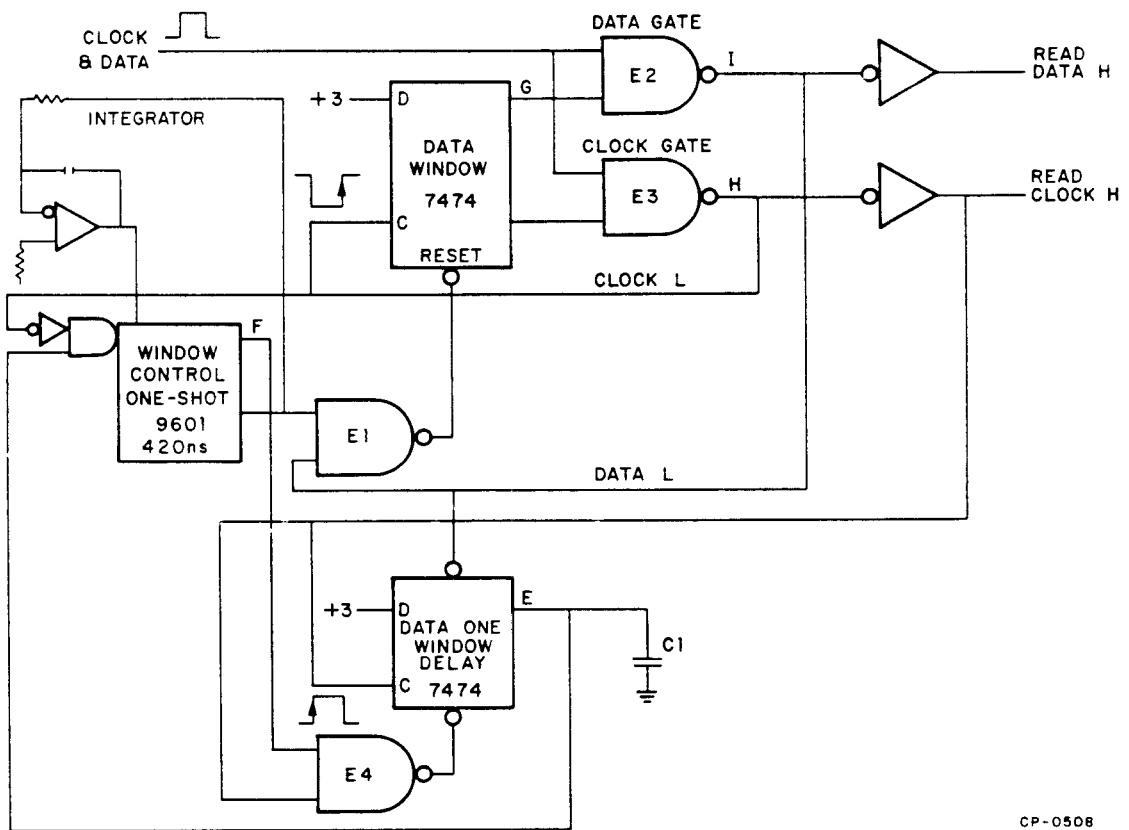

CP-0508

Figure 4-15 Simplified Data Separator Circuit

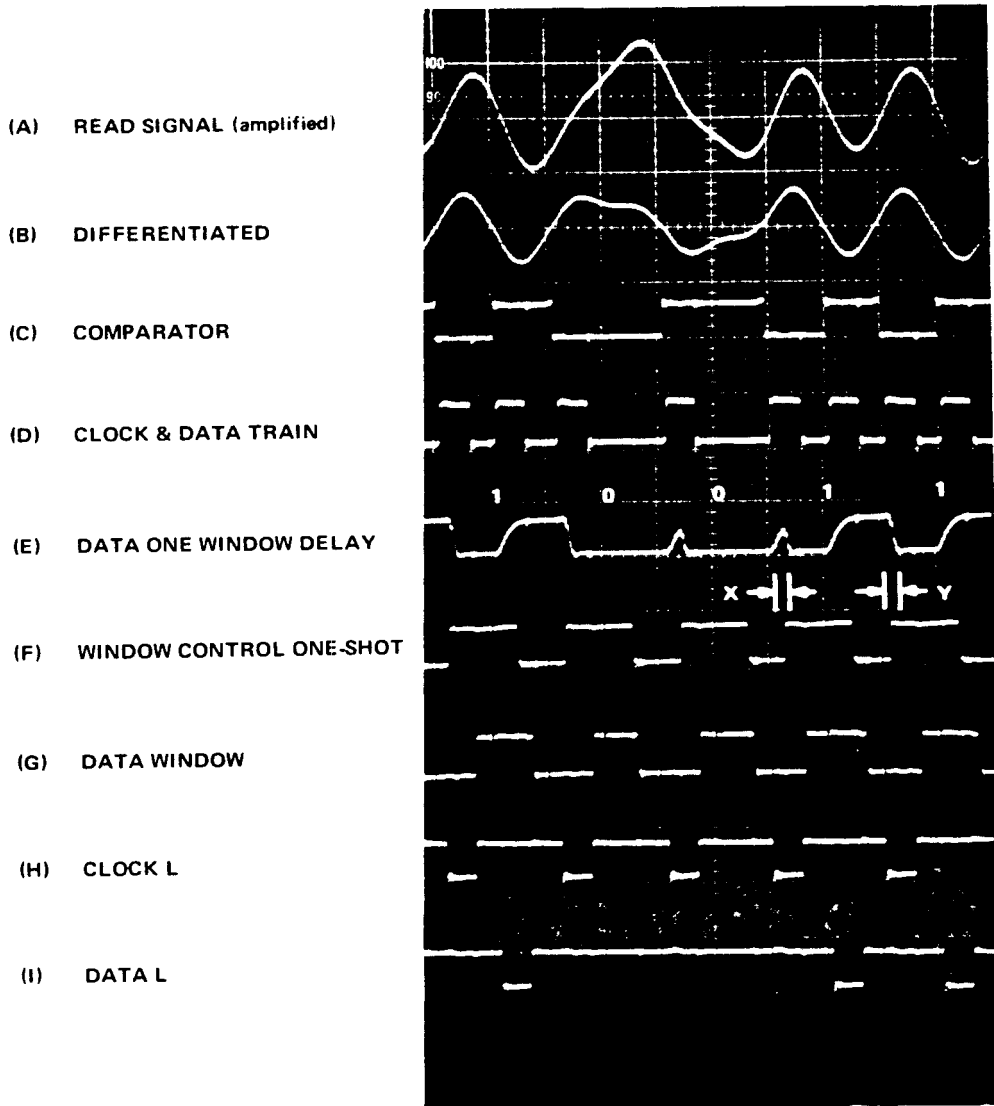

X = DELAY FOLLOWING ZERO
 Y = NO DELAY FOLLOWING ONE

Figure 4-16 Read Waveforms

As flux reversals on the disk surface pass under the lower read head, induced current flows through the lower head coil. The direction of this current flow depends upon the polarity of the flux reversal. These small read signals (approximately 5 mV) are then transmitted through the head-select diodes, through the series-isolation diodes, to a differential read preamplifier. The diode, resistor, and capacitive network between the read/write coils and the read preamplifier automatically isolates the preamplifier from the large write signals that occur during a write operation; however, this isolation circuit allows the small read signals that occur during a read operation to pass.

The amplified output from the preamplifier (approximately 300 mV) is then transmitted through a low-pass filter network to the read amplifier. The filter network removes noise and high-frequency disturbance but permits the lower frequency read signals to pass. The approximate 3.0 V read amplifier output (A) is applied to a balanced delay circuit where the signal is differentiated (B) and the signal peaks converted into zero crossings. The complementary zero crossings are then applied to a pair of high-gain differential comparators that convert the differentiated signal into square waves. Each square wave signal (C) triggers a corresponding one-shot, the outputs of which are combined to produce a composite 150-ns pulse train (D).

At this point, data and clock pulses are separated from the pulse train. Figure 4-15 is a simplified diagram of the data separation circuit. For a basic understanding of the following description; assume that the Data One Window Delay flip-flop remains set, keeping the input gate of the Window Control one-shot enabled.

If the Data Window flip-flop is in the reset state (G) when the leading edge of the first pulse on the pulse train occurs, the clock gate (E3) is enabled to produce the BUS RD CLK L signal (H) and to trigger the Window Control one-shot (F). The reset output from this one-shot is applied to an integrator circuit. After integration, the average voltage output is then applied to the adjustable input of the one-shot. Thus, if data frequency variations occur, this circuit configuration automatically varies the one-shot pulse width and thus maintains a constant duty cycle.

Triggering the Window Control one-shot also removes the reset input of the Data Window flip-flop so that the trailing edge of the first clock pulse will clock the Data Window flip-flop set. Approximately 290 ns after this sets (slightly more than one-half bit cell), the Window Control one-shot will time out. If another pulse occurs on the pulse train (data 1 bit) before the time out, it will be enabled in the Data Gate (E2) to produce BUS RD DATA L (I), which will also keep the Data Window reset gate (E1) disabled for the duration of the data pulse so that the Data Window flip-flop will not be reset during the data pulse by the one-shot time out.

If another pulse did not occur (data 0 bit), the Data Window flip-flop will be reset by the one-shot time out via the Data Window reset gate.

In some bit sequences (e.g., a data 1 following a data 0), it is desirable to delay the resetting of the Data Window slightly longer than the normal one-shot time out. A magnetic recording phenomenon known as peak shift can cause the data 1 bit to lie beyond the cell center. A delaying circuit is provided so that whenever a data 0 bit occurs, reset of the following Data Window flip-flop is delayed, regardless of what the following data bit may be.

To accomplish this, a Data One Window Delay flip-flop set output is used to enable the Window Control one-shot.

The occurrence of a data 1 pulse direct-sets the Data One Window Delay flip-flop. The set output (E) then provides an enable signal to the Window Control one-shot so that the next clock pulse triggers the one-shot without delay. If a data bit is 0, the Data One Window Delay is not set until the leading edge of the following clock pulse. The set output rise is slowed by capacitor C1. This slow rise, gated with BUS RD CLK L, prevents the immediate firing of the one-shot, thus delaying the Data Window flip-flop reset. The one-shot firing also resets the Data One Window Delay via its reset gate (E4). This allows the Data One Window Delay flip-flop to be set by a possible data 1 pulse.

4.4.2 Write Operation

During a write operation, multiplexed write data and clock pulses are applied to the complementary Write Encode flip-flop. If the Write Gate signal is present and one of the read/write heads has been selected, current flows through the erase coil as well as through one-half of the center-tapped write coil. Each pulse on the multiplexed input complements the Write Encode flip-flop and transfers current flow to the opposite half of the write coil; however, current flow through the erase coil remains constant throughout the write operation.

To initiate a write operation, the controller:

1. Addresses a particular drive (Paragraph 4.2.4).
2. Positions the read/write heads at the appropriate cylinder (Paragraph 4.2.5).
3. Selects either the upper or lower read/write head (Paragraph 3.2.5).

For example, if the lower read/write head is to be used, HD SELECT (G180-0-1) is high. This signal is ANDed with UNSAFE L (high, if no fault condition exists, Paragraph 4.5) to apply a ground potential to the center tap of the lower head.

At this point, the controller transmits the BUS WT GATE L signal, which is ANDed with SELECT/READY L to generate the signal SELECTED WRITE GATE H. The multiplexed data to be recorded is then transmitted over the BUS WT DATA & CLK L interface line. If the WT PROT switch is off (drive not write-protected), the signal NO PROTECT L accomplishes the following:

1. ANDs with BUS R/W/S READY/ON CYL L to complete the base current return circuit for the write drivers (Q1 and Q2).
2. ANDs with BUS WT DATA & CLK L to apply the data train to the complementary Write Encode flip-flop.

NOTE

The Write Encode flip-flop operates between +10 V and +15 V instead of the usual ground and +5 V levels.

When the BUS WRITE DATA & CLOCK pulse goes low, the Write Encode flip-flop sets, applying the +10 V reset output to the base of write driver Q2, causing it to conduct. With Q2 conducting, approximately 32 mA of current (adjustable with R13) flows through the upper portion of the lower write coil. In addition, a low voltage is applied to the base of the Erase Current Switch (Q3), causing it to conduct. When Q3 conducts, one leg of the Unsafe gate is enabled (Paragraph 4.5.1) and erase current flows through the lower erase coil.

When the BUS WRITE DATA & CLOCK pulse goes low again, the Write Encode flip-flop resets, causing write driver Q1 to conduct and Q2 to cut off. This circuit configuration transfers the current path to the lower portion of the lower write coil; however, the current direction in the erase coil remains constant. Thus, with each current transfer in the head coil, a flux reversal is recorded on the rotating disk surface.

4.5 FAULT DETECTION

If during normal operation the following three fault conditions are detected, all external commands to the drive are suppressed and the FAULT indicator on the drive control panel lights. The fault conditions are:

1. Erase or write current without a BUS WT GATE L signal.
2. Linear positioner transducer lamp inoperative.
3. Any or all of +15, -15, or +5 Vdc low (dc low).

4.5.1 Current Fault

During a write operation, write driver Q1 or Q2 (G180-0-1), depending upon the polarity of the input data, is conducting. The low voltage output from either write driver turns on Erase Current Switch Q3 to enable one leg of the Unsafe gate. If BUS WT GATE L is present, the second leg of this gate is disabled; thus, Q4 conducts to keep the signal SET UNSAFE L high.

If for any reason (e.g., shorted transistor), the Erase Current Switch should conduct without a BUS WT GATE L signal present, the Unsafe gate is enabled. This action turns off Q4 to generate SET UNSAFE L, which accomplishes the following:

1. Sets the Fault latch (M7701).
2. Generates the BUS WT CHK L signal and lights the FAULT indicator (M7701).
3. Deselects both read/write heads (G180-0-1).

4.5.2 Positioner Lamp Fault

This fault condition can only be detected when the read/write heads are in the home position. If the positioner lamp fails at any other time, various other checks will disclose this fact (e.g., BUS SIN L generated or BUS R/W/S READY L never generated, etc.). Therefore, the positioner lamp check is accomplished during the initial power-on cycle, or if the heads drift back to the home position after having once been loaded.

If the lamp fails and the heads are in the home position, HOME H (M7701) is present; however, OUTER LIMIT H (heads are at or beyond the outer portion of the disk) is low. This signal combination sets the Fault latch to light the FAULT indicator and generate the BUS WT CLK L signal.

4.6 POWER SUPPLY DESCRIPTION (Figure 4-17)

The RK05 Disk Drive power supply (H743) and associated electronic cards are located in the left-rear portion of the disk drive. The power supply itself can be operated from a 115 or 230 Vac line voltage input, and consists of a dual transformer, two bridge rectifiers, and three voltage regulators. For 115 Vac operation, jumpers between P2 pins 1 and 2 and P2 pins 3 and 4 connect the dual primaries of transformer T1 in parallel. For 230 Vac operation, one jumper between P2 pins 2 and 3 connects the dual primaries of transformer T1 in series, thus maintaining 115 Vac across each primary. In either configuration, the 115 Vac blower motor is connected across T1 pins 1 and 2, while the 115 Vac spindle motor is connected across T1 pins 3 and 4.

When the power supply is activated, the secondary output of T1 pins 7 and 8 is applied through full-wave bridge rectifier D2, across capacitor C2, to the input of both the +15 V and +5 V regulators. The other T1 secondary output is likewise applied through full-wave bridge rectifier D1, across capacitor C1, to the input of the -15 V regulator. The regulator outputs are maintained within the following specified voltage limits, measured to center value of the peak-to-peak ripple from ground:

- | | |
|-----------------------|--|
| 1. +15 \pm 0.75 Vdc | } 200 mV peak-to-peak maximum ripple on any of the regulators,
and 250 mV peak-to-peak maximum ripple on dc voltage pins
of the logic assembly |
| 2. -15 \pm 0.75 Vdc | |
| 3. +5 \pm 0.15 Vdc | |

All three regulators contain current-limiting circuitry and are further protected against short circuits by a permanent fuse. Only the +5 Vdc regulator (logic power) contains a nonadjustable Zener diode for automatic overvoltage protection.

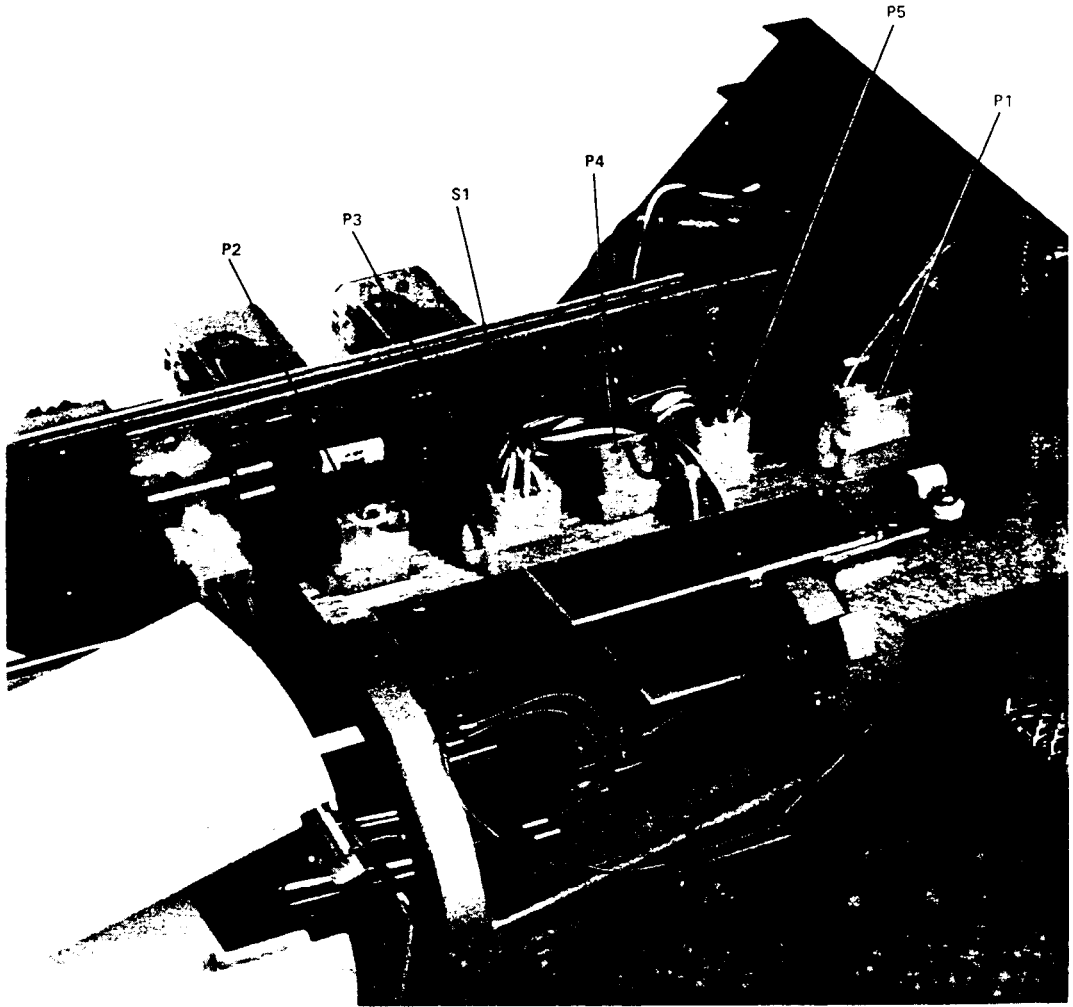

6858-3

Figure 4-17 Internal Power Supply Connections

CHAPTER 5 MAINTENANCE

5.1 CUSTOMER EQUIPMENT CARE

Because the cartridge is not a sealed unit and is extremely vulnerable to dirt, care must be taken to keep the cartridge and the interior of the drive clean. Smoke particles, fingerprint smudges, or dust specks can cause head crashes and catastrophic destruction of the heads and disk surfaces, as Figure 1-12 shows. For this reason, there are practices and procedures that the customer can follow which should contribute to the performance and longevity of the RK05.

5.1.1 Weekly Care

Every week (or more frequently, depending upon activity) the customer should:

1. Clean the front window of the drive, using a lint-free wipe or cloth moistened with glass cleaner.
2. Remove any accumulated dust buildup from the front panel, using a dry, lint-free wipe or cloth.

5.1.2 Monthly Care

Every month (or more frequently, depending upon activity) the customer should:

1. Inspect the interior of disk cartridges for visible dirt or damage.
2. Check that cartridge doors close properly.
3. Check that cartridge air vent door rivets are not broken.
4. Check that retainer buttons on the bottom of cartridges are not being chewed up; this could cause plastic shavings to fall into cartridges.
5. Remove any dust or dirt from the exterior of cartridges, using a lint-free wipe or cloth dampened with water.
6. Vacuum the outer face of the prefilter (Figure 5-1). If there is excessive dirt on the prefilter, remove the filter and clean it with a mild liquid detergent and warm water. Using the exhaust of the vacuum cleaner, air-dry the filter completely before reinstalling it.

5.2 PREVENTIVE MAINTENANCE

Information regarding preventive maintenance of the RK05/RK05-J/RK05-F Disk Drives is contained in the following publications:

RK05/RK05-J Disk Drive Preventive Maintenance Procedures (EK-RK05J-PM-001)
RK05-F Disk Drive Preventive Maintenance Procedures (EK-RK05F-PM-001)

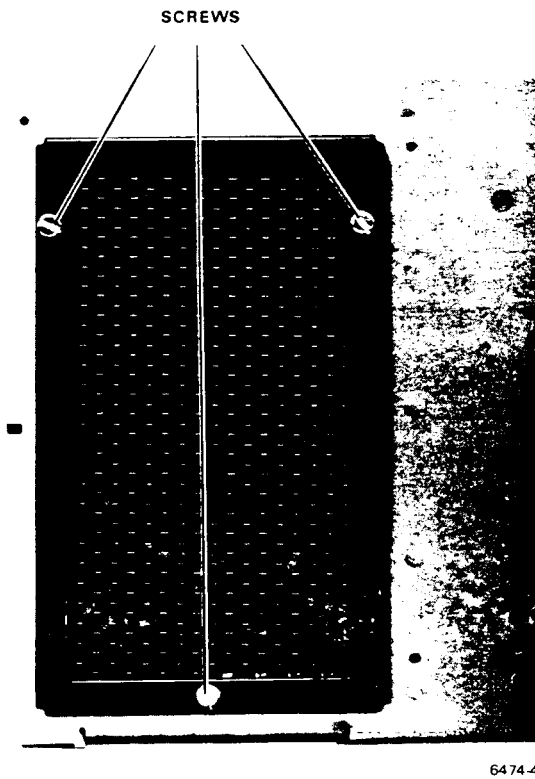

Figure 5-1 Prefilter

Table 5-1 lists the recommended tools and test equipment to be used with standard tools for proper maintenance of the RK05/RK05-J/RK05-F Disk Drive. During the PM procedures, do not alter any adjustments on drives that are performing within specifications, unless specifically indicated.

Table 5-1 Recommended Tools and Test Equipment

Equipment	Manufacturer and Model/Part No.
Multimeter	Triplet 310, or Simpson 360
Oscilloscope	Tektronix 453, or equivalent
Oscilloscope probes, voltage	Tektronix P6010
Screwdriver, Phillips, small	Vaco P-1, or equivalent
Wire wrap tool (30-gauge)	DEC H811A
Unwrapping tool (30-gauge)	DEC H812A
Module Extender Board*	DEC H982
Wrench set (10-piece)	29-13519
Torque wrench assembly, 55 oz-inch (for old head clamping screws)	29-20994
Torque wrench tip, 55 oz-inch	29-20995
Torque wrench assembly, 125 oz-inch (for new head clamping screws)	29-22521
Torque wrench tip, 3/32 inch Allen	29-22522
Extension bar, 6-inch	29-20907
Hex-head wrench, 3/16-inch	29-20908
Head-cleaning kit includes Tex pads (29-19557) and wand (29-19558)	22-00007
Inspection mirror	29-19663
Isopropyl alcohol, one pint (91%)	29-19665
Alignment cartridge	RK05-AC
Spring hook, teletypewriter	29-12528

*Not to be used for G180 module.

5.3 CORRECTIVE MAINTENANCE

5.3.1 Linear Positioner

5.3.1.1 Positioner Removal

NOTE

Before removing wires, check that they conform to the configuration indicated on the wire replacement chart (Table 5-2).

CAUTION

Bumping of the positioner on the baseplate or locating pins may raise burrs that will severely mislocate the positioner upon reinstallation.

Table 5-2 Positioner Transducer Wire Configuration

● Green/White	● Blue	
● White/Black	● Yellow	
● Green/Black	● Green	
● Blue/White	● Orange	
● Blue	● Gray	
● Blue/Black	● Brown	
● Black/White	● Red	
● Orange/White	● White	} Reference – +5 Vdc to linear encoder lamp
● Black	● White	

1. Remove the disk cartridge from the drive.
2. Open the rear door of the rack and unplug the drive ac line cord.
3. Slide the drive out of the rack until it locks in the extended position.
4. Remove the top and bottom covers.
5. Remove the read/write heads as described in Paragraph 5.3.3.2.
6. Install the linear motor (positioner) shipping bracket.
7. Disconnect P5 (Figure 4-17) from the power supply chassis.
8. Remove the positioner transducer wires from TB1 pins 1 through 9, and from TB2 pins 8 and 9. Note the order, to aid in replacement.
9. Disconnect the head connectors from the electronic module (G180).
10. Remove the three screws beneath the baseplate that attach the positioner to the baseplate (Figure 5-2).
11. Carefully maneuver the positioner off the locating pins on top of the baseplate, and lift the positioner straight up from the baseplate.

5.3.1.2 Positioner Replacement

1. Carefully place the positioner on the three locating pins on top of the baseplate. Ensure that the two front pins rest against the front surface of the motor housing and the third diamond-shaped pin is in the center hole of the mounting face.
2. Insert the three positioner holding screws (Figure 5-2) through the bottom of the baseplate and finger-tighten the screws.
3. Ensure that the positioner is located securely against the front locating pins by tightening the holding screws with a torque wrench (set to 65 pound-inches) while applying forward pressure to the rear of the positioner.

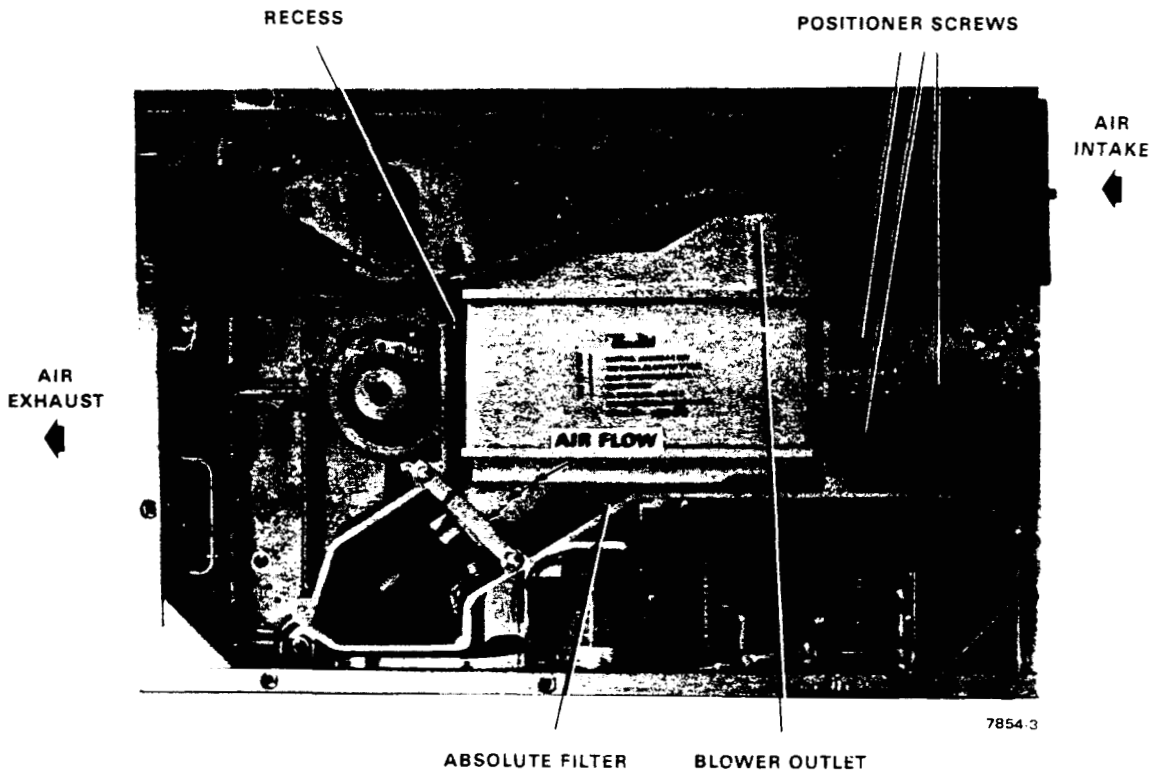

Figure 5-2 Absolute Filter Removal

4. With a feeler gauge, ensure that clearance between the front of the linear motor housing and the two front pins is less than 0.002 inch. If not, loosen the positioner holding screws and repeat Step 3, above.
5. Connect the positioner transducer wires to TB1 and TB2 (Figure 5-3).

NOTE

Refer to the chassis wiring diagram for TB1 and TB2 connection color code.

6. Remove the linear motor (positioner) shipping bracket.
7. Plug P5 (Figure 4-17) into the power supply chassis.
8. Replace the read/write heads as described in Paragraph 5.3.3.3.
9. Connect the head leads to the electronic module (G180). (Refer to the pin number decal on the logic assembly and to schematic CS-G180 for plug locations.)
10. Connect the ac line cord and check read/write head alignment (Paragraph 5.4.5).
11. Replace the bottom covers, and then replace the top cover.

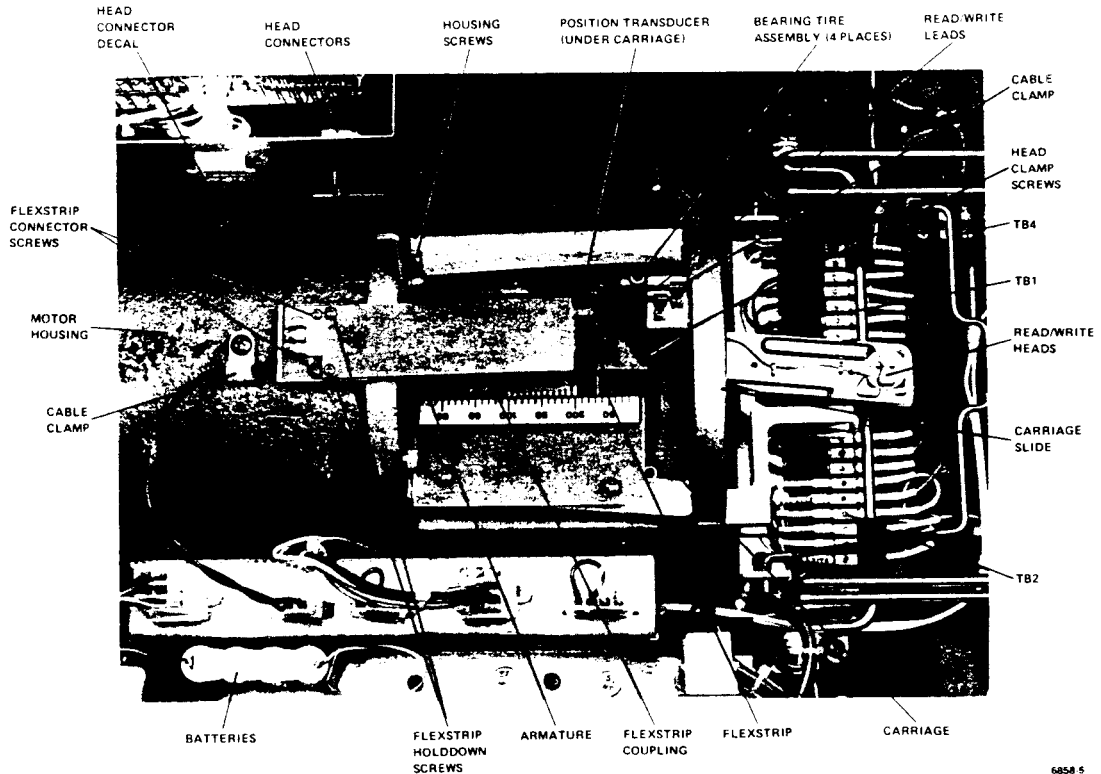

Figure 5-3 Top View of RK05 with Cover Removed

12. Close the rear door, install a test cartridge, and exercise the drive.

NOTE

The top head should connect to the pins farthest from the logic block.

5.3.2 Carriage

5.3.2.1 Carriage Removal

1. Remove the linear positioner (Paragraph 5.3.1.1).
2. Remove the read/write heads (Paragraph 5.3.3.2).
3. Remove the four flexstrip connector and flexstrip hold-down screws (Figure 5-3). Do not disconnect the flexstrip coupling from the armature.
4. Remove the cable clamp screw from the top of the motor housing.
5. Remove the home switch and bracket from the carriage slide.
6. Remove the five screws securing the carriage slide to the motor housing.
7. Slowly pull the carriage and slide straight out from the motor housing.

8. Slide the carriage and armature out from the back of the carriage slide, ensuring that the transducer block does not contact the glass scale.

5.3.2.2 Carriage Replacement

1. Carefully insert the armature and carriage into the motor housing, ensuring that the dowel pin on the housing goes into the V-groove on the carriage slide.
2. Replace the five screws that secure the carriage slide to the motor housing (Figure 5-3).
3. Loop the flexstrip onto the top of the motor housing and replace the four flexstrip connector and hold-down screws.
4. Replace the cable clamp.
5. Replace the home switch and bracket on the carriage slide.
6. Stand the positioner up on the motor housing end; adjust the home switch as follows:
 - a. Pull the carriage out from the motor housing until the switch actuator on the carriage is free from the switch.
 - b. Hold a steel scale across the machined face of the carriage slide and stand another scale on the machined face (near the head mounting holes) of the carriage.
 - c. Slowly move the carriage in toward the motor housing until the home switch clicks. At this point, the vertical steel scale on the carriage face should indicate 2.050 ± 0.020 inches.

NOTE

The switch check and adjustment must be made on the backward click of the home switch, NOT while the carriage is moving forward.

- d. If the switch adjustment is incorrect, bend the leaf actuator on the switch until the measurement from Step c, above, is attained.
7. Replace the read/write heads (Paragraph 5.3.3.3).
 8. With a piece of blue plastic shim stock, check for 0.005-inch clearance between the transducer glass scale and reticle. If the clearance is incorrect, loosen the transducer block mounting screws and position the block to obtain the correct clearance.

NOTE

Do not lose the front-to-back position obtained in Step 6. Reference lines may be drawn on the slide before the block is loosened.

9. Replace the linear positioner (Paragraph 5.3.1.2).
10. Perform the servo system timing adjustment (Paragraph 5.4.2).
11. Check the read/write head alignment (Paragraph 5.4.5).

5.3.2.4 Carriage Bearing Assembly Replacement

1. Examine the bearing (P/N 12-11475) for a groove running around the outer diameter of the tire. If the groove is absent (Figure 5-4a), insert the bearing into the bearing pocket with the widest machined surface of the bearing toward the threaded hole in the pocket. If the groove is present (Figure 5-4b), insert the bearing into the bearing pocket with the groove nearest the threaded hole.
2. Insert the bearing shaft into the threaded pocket hole and through the center hole in the bearing.
3. Turn the 3/8-inch bearing shaft nut just a few turns to start the shaft threads into the pocket hold threads. Do not tighten the shaft at this time.
4. Insert the bushing on the other end of the shaft and replace the retaining nut.

NOTE

When performing Steps 5 and 6, do not allow the bearing assembly to touch the top or bottom of the carriage pocket.

5. Hold the 3/8-inch bearing shaft nut and tighten the retaining nut until the bushing moves the bearing close to the pocket top. Then tighten the 3/8-inch bearing shaft nut until the bearing moves close to the pocket bottom.
6. Continue alternate nut tightening as described in Step 5, above, until the bearing shaft and retaining nuts are secure.
7. Replace the carriage in the linear positioner (Paragraph 5.3.2.2).
8. Replace the linear positioner (Paragraph 5.3.1.2).
9. Check the read/write head alignment (Paragraph 5.4.5).

5.3.2.5 Transducer Block Removal and Replacement

1. Remove the linear positioner (Paragraph 5.3.1.1).
2. Remove the clamp attaching the positioner transducer leads to the carriage slide.
3. Remove the two screws attaching the transducer block to the carriage slide and carefully maneuver the transducer block out of the slide, ensuring that the block does not scratch the glass scale.
4. Install the new transducer block on the carriage slide with the previously removed hardware.
5. Replace the transducer leads in the clamp and attach the clamp to the carriage slide.
6. With a piece of blue plastic shim stock, ensure that the clearance between the transducer glass scale and the reticle is 0.005 inch. If the clearance is incorrect, loosen the transducer block mounting screws and reposition the block to obtain the correct clearance.
7. Replace the linear positioner (Paragraph 5.3.1.2) and perform the servo system timing adjustment (Paragraph 5.4.2).
8. Align the read/write heads (Paragraph 5.4.5).

5.3.2.3 Carriage Bearing Assembly Removal

1. Remove the linear positioner (Paragraph 5.3.1.1).
2. Remove the carriage from the linear positioner (Paragraph 5.3.2.1).
3. Using a 3/8-inch nut driver, loosen the bearing shaft nut (Figure 5-4) one-half turn.
4. Hold the 3/8-inch bearing shaft nut and remove the retaining nut from the other end of the shaft.
5. Remove the bushing from the shaft and unscrew the bearing shaft.
6. Remove the bearing.

NOTE

Replace all four bearings at the same time.

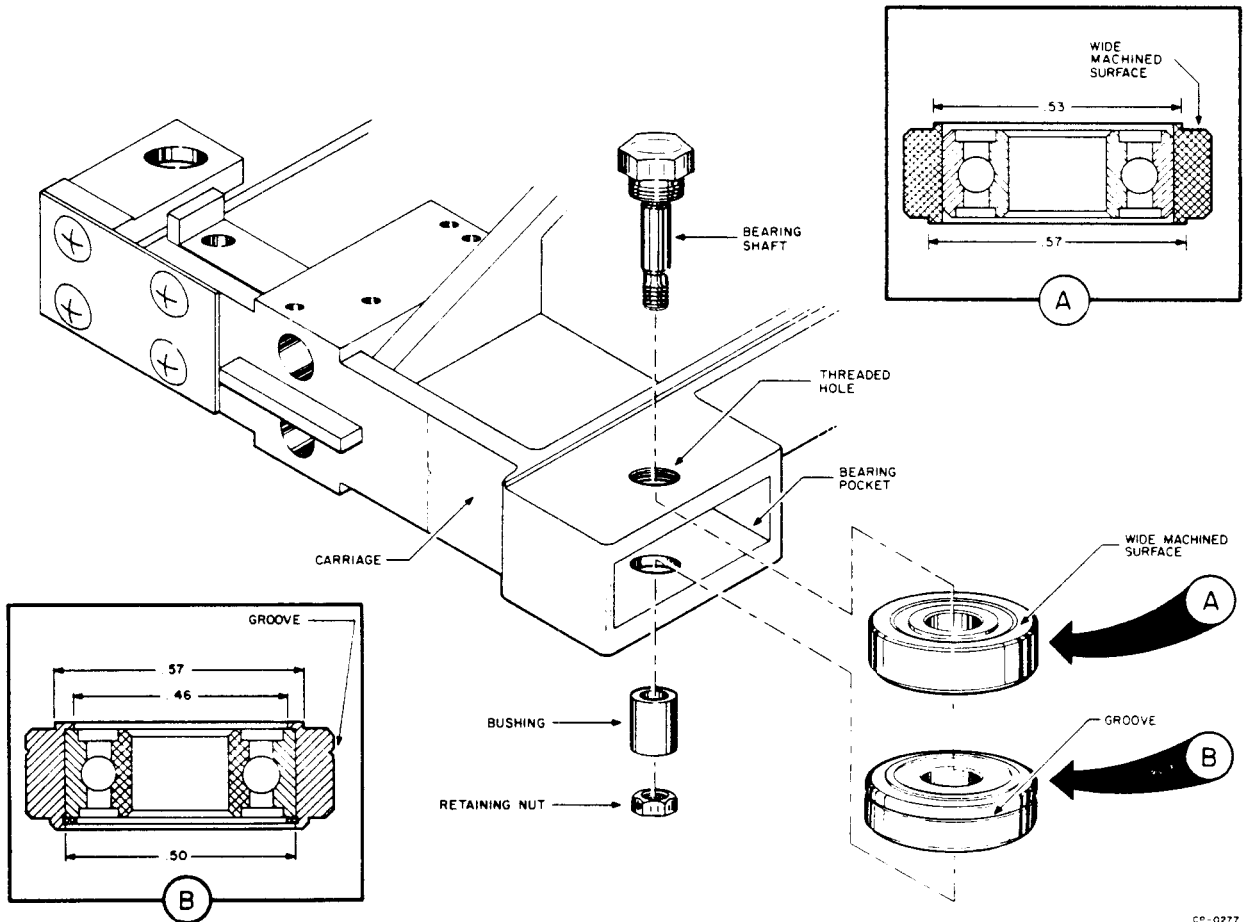

CP-0277

Figure 5-4 Carriage Bearing Assembly Removal

5.3.2.6 Transducer Bulb Replacement – Burned-out transducer bulbs may be replaced without disassembly of the transducer block from the positioner by using lamp assembly 30-10636-03 and clamp assembly 70-12691-0-0.

5.3.3 Read/Write Heads

5.3.3.1 Carriage Revisions – Older carriages employ conical-tipped head-clamping screws that bear on the facets on the side of the support arm. These set screws are to be driven with a hex screw bit (29-20995) mounted in a torque wrench set at 55 ounce-inches of torque (Figure 5-5a).

Newer carriages employ brass-tipped clamping screws that bear on the solid diameter of the support arm. These set screws are to be set with a hex screw bit (29-22522) mounted in a torque wrench set at 128 ounce-inches of torque (Figure 5-5b).

5.3.3.2 Head Removal

1. Remove the disk cartridge from the drive.
2. Open the rear door of the rack and unplug the drive ac line cord.
3. Slide the drive out of the rack until it locks in the extended position.
4. Remove the top cover.
5. Disconnect the head connectors (Figure 5-3) from the electronic module.
6. Disconnect P5 (Figure 4-17) from the power supply chassis.
7. Remove the head clamp and head adjusting screws.
8. Retract the carriage to unload the heads and carefully remove the upper head (Figure 5-6a).
9. Extend the carriage and remove the lower head (Figure 5-6b).

5.3.3.3 Head Replacement

1. Extend the carriage and insert the lower head tailpiece into the carriage (Figure 5-6b).
2. Retract the carriage to the home position so that the lower head is supported by the lifting block on the duckbill.
3. To install the upper head, it is necessary to straighten the head from its natural position. Carefully install the upper head as follows:
 - a. Insert the end of the tailpiece slightly into the carriage hole (Figure 5-6a).

CAUTION

Exercise extreme care while performing Step b, below. If the yield point of the spring is exceeded during the straightening process, the loading force on the head will change.

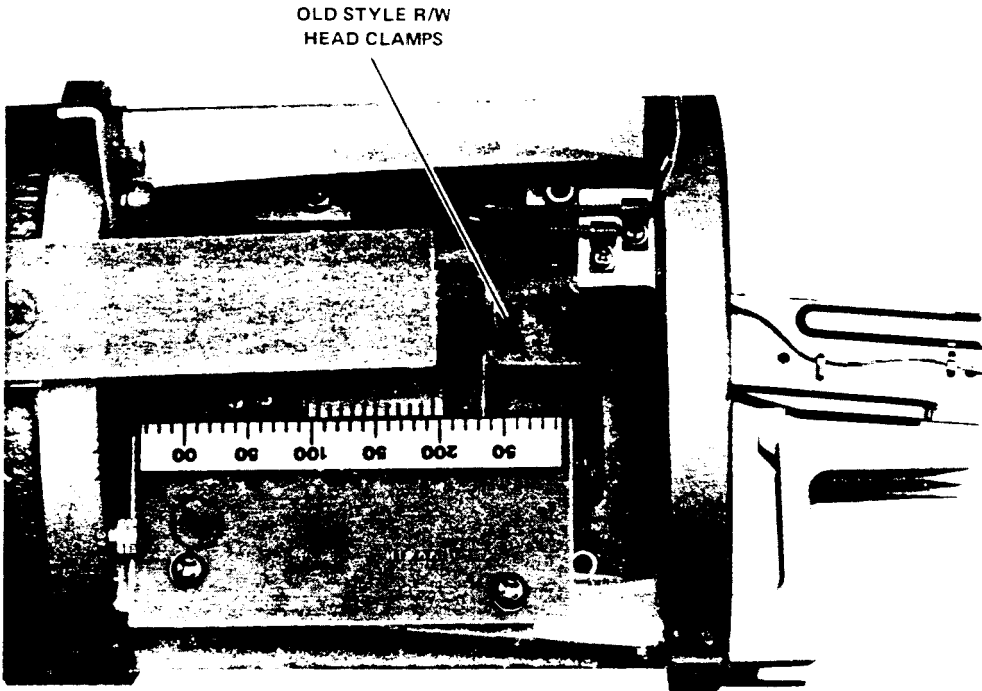

6858-5

(a) Older Style Carriage

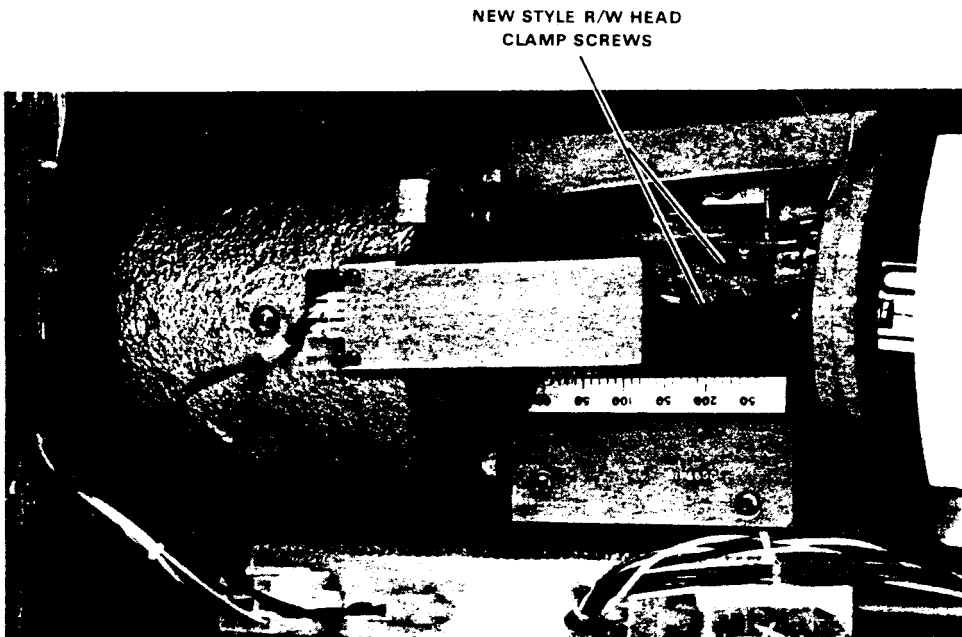

7854-2

(b) Newer Style Carriage (RK05-F Shown - No Cartridge Receiver)

Figure 5-5 Read/Write Head Carriage Revision

CARRIAGE (HELD RETRACTED)

P5



UPPER HEAD
TAIL PIECE

CLAMP SCREW
HOLES

ADJUSTING
SCREW HOLES

CLAMP



LOWER HEAD

LOWER HEAD
TAIL PIECE

CARRIAGE
HELD EXTENDED

(b) Lower Head Removal and Installation

Figure 5-6 Read/Write Head Replacement

- b. Simultaneously press down at the front of the tailpiece and lift the front of the suspension spring while pushing the head backward. This process tends to straighten the head suspension spring for easier insertion into the carriage hole. Do not over-bend the suspension spring, and avoid touching the ceramic surfaces of the head pads during installation.
4. Replace the head clamp and adjusting screws (Figure 5-6a) and using the appropriate torque wrench (Paragraph 5.3.3.1), tighten the clamp screws with the heads located approximately 0.030-inch from the fully-seated position.
5. Replace the read/write head cables in the clamp on the carriage slide and connect the head connectors to the electronic module. Refer to the decal on the chassis for the correct lead connections.
6. Plug P5 into the power supply chassis.
7. Check the read/write head alignment (Paragraph 5.4.5).
8. Perform the index/sector timing adjustment (Paragraph 5.4.4).
9. Replace the top cover.
10. Close the rear door.

5.3.4 Spindle

5.3.4.1 Spindle Removal

CAUTION

Any bumping of the spindle on the baseplate may raise burrs that will severely mislocate the spindle upon reinstallation.

1. Remove the disk cartridge from the drive.
2. Open the rear door of the rack and unplug the drive ac line cord.
3. Slide the drive out of the rack until it locks in the extended position.
4. Remove the top and bottom covers.
5. If a cartridge receiver is present, remove the tension springs from the cartridge receiver (Figure 5-7) and raise the receiver as high as possible.
6. Remove the flexible magnet from the spindle armature to expose the access hole in the spindle plate.
7. Position the access hole over each of the spindle retaining screws and remove them. Do not apply any force to the spindle armature plate (0.000150-inch runout).
8. Lift the spindle free from the drive baseplate.

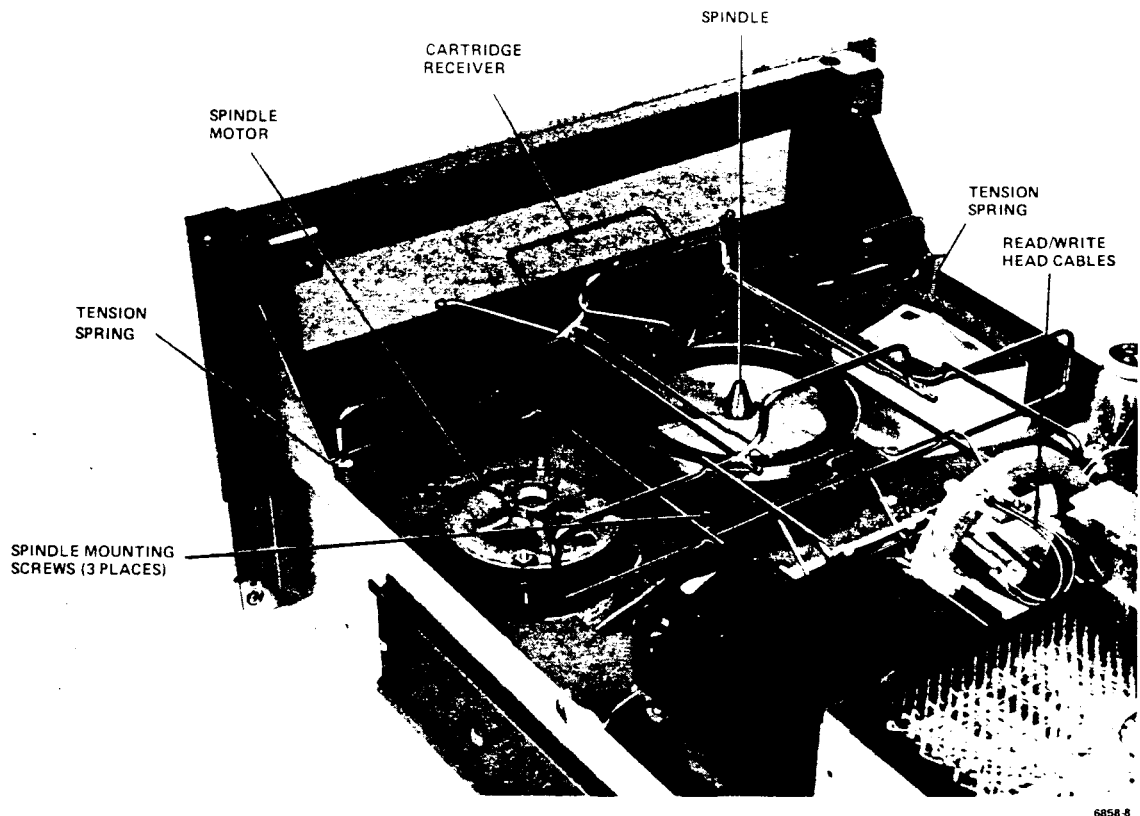

Figure 5-7 Spindle Replacement

5.3.4.2 Spindle Replacement

1. If a cartridge receiver is present, raise the cartridge receiver as high as possible and install the spindle on the baseplate with the previously removed hardware. Avoid damaging either the baseplate mounting surfaces or the spindle flange; this could cause the spindle to seat as much as several thousandths of an inch out of its proper position.
2. Lower the cartridge receiver and attach the tension spring (Figure 5-7).
3. Push the spindle motor mounting plate (Figure 5-8) toward the spindle and slip the drive belt around the pulleys.
4. Connect the ac line cord and check the read/write head alignment (Paragraph 5.4.5).
5. Replace the top and bottom covers.
6. Slide the drive into the rack and close the rear door.

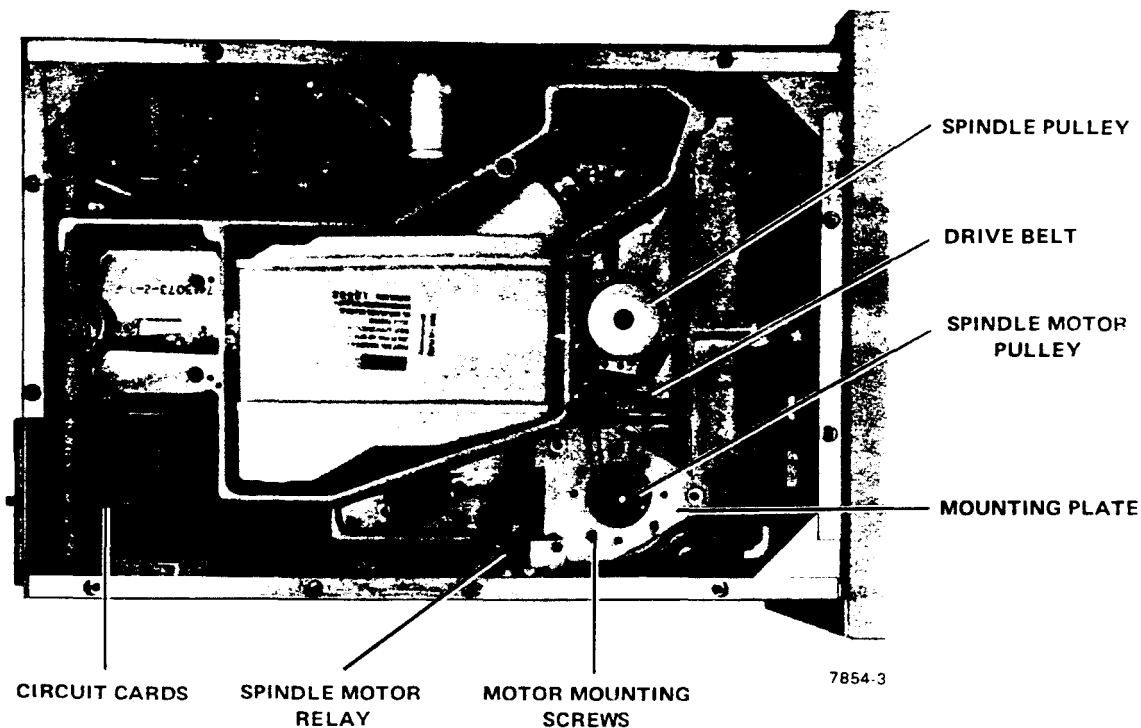

Figure 5-8 Drive Belt

5.3.4.3 Spindle Ground (Carbon Brush) Removal and Replacement

1. Open the rear door of the rack and unplug the drive ac line cord.
2. Slide the drive out of the rack until it locks in the extended position.
3. Remove the bottom covers and remove the two screws that attach the carbon brush assembly to the spindle (Figure 5-9).
4. Mount the new brush assembly on the spindle and ensure that the curved brushes are centered on the spindle hub and that the brush assembly is not cocked or twisted. Full contact between the curved surfaces of the brushes and shaft is necessary to prevent brushes from squealing.
5. Tighten the brush assembly mounting screws and replace the bottom covers.
6. Slide the drive into the rack, reconnect the ac line cord, and close the rear door.

5.3.5 Spindle Drive Motor

5.3.5.1 Motor Removal

1. Remove the disk cartridge from the drive.
2. Open the rear door of the rack and unplug the drive ac line cord.

FOR 50 Hz OPERATION
MOVE MOTOR MOUNTING
SCREWS TO THESE HOLES (4)

CARBON BRUSH ASSEMBLY
MOUNTING SCREWS

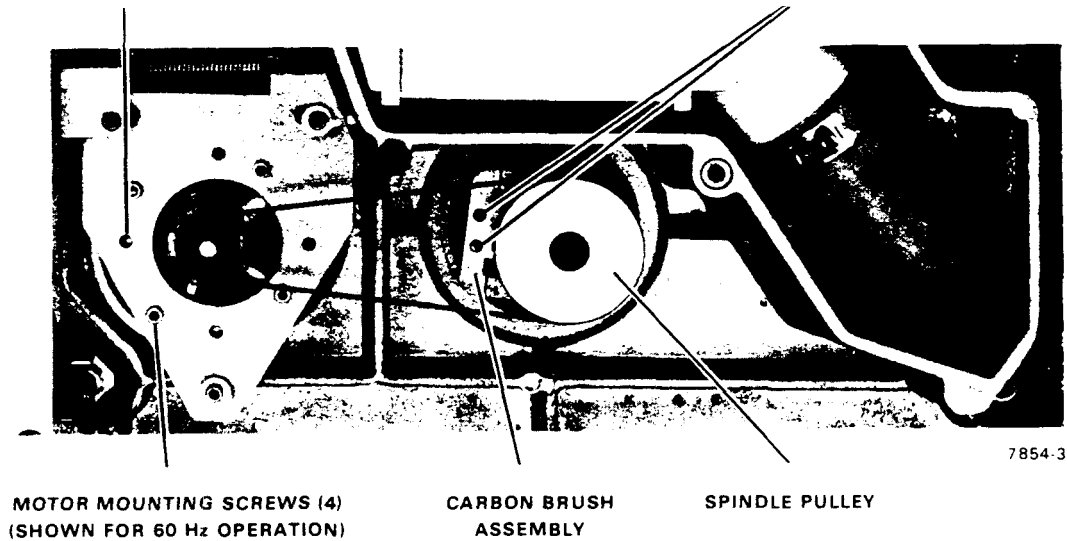

Figure 5-9 Carbon Brush Replacement

3. Slide the drive out of the rack until it locks in the extended position.
4. Remove the top and bottom covers.
5. Disconnect the spindle motor leads from TB4 (Figure 5-3) and from the spindle motor relay (Figure 5-8).
6. Remove the drive belt (Figure 5-8) by pushing the spindle motor mounting plate toward the spindle to relieve belt tension, and then slipping the belt off the pulleys.

NOTE

The spindle motor mounting plate contains two sets of holes, one for 50-Hz operation, the other for 60-Hz operation. Before performing Step 7, below, note which set of holes is being used, to ensure correct replacement of the motor (Figure 5-9).

7. Remove the four screws attaching the motor to the mounting plate and remove the motor through the top of the baseplate.

5.3.5.2 Motor Replacement

1. Insert the spindle motor through the top of the baseplate (Figure 5-7) and attach the motor to the mounting plate with the previously removed hardware.
2. Push the spindle motor mounting plate toward the spindle and slip the drive belt around the pulleys.

3. Connect the spindle motor leads to TB4 (Figure 5-3) and to the spindle motor relay (Figure 5-8a). Refer to the chassis wiring drawing for TB4 and the spindle motor relay connection color code.
4. Check the read/write head alignment (Paragraph 5.4.5).
5. Replace the top and bottom covers.
6. Slide the drive into the rack and connect the ac line cord.
7. Close the rear door.

5.3.5.3 Drive Belt Removal and Replacement

1. Remove the disk cartridge from the drive.
2. Open the rear door of the rack and unplug the drive ac line cord.
3. Slide the drive out of the rack until it locks in the extended position.
4. Remove the bottom cover.
5. Push the spindle motor mounting plate (Figure 5-8a) toward the spindle to relieve belt tension, and then slip the belt off the pulleys.
6. Clean the spindle and drive motor pulleys with a clean cloth moistened with 91% isopropyl alcohol.
7. Install a new drive belt by pushing the spindle motor mounting plate toward the spindle and slipping the drive belt around the pulleys. *Do not stretch the belt!*
8. Replace the bottom cover.
9. Slide the drive into the rack and connect the ac line cord.
10. Close the rear door.

5.3.6 Blower Motor

5.3.6.1 Blower Removal (Figure 5-10)

1. Remove the disk cartridge from the drive.
2. Open the rear door of the rack and unplug the drive ac line cord.
3. Slide the drive out of the rack until it locks in the extended position.
4. Remove the top and bottom covers.
5. Disconnect the blower leads from TB4 (Figure 5-3).
6. Remove the four blower mounting screws and carefully remove the blower and shroud from the baseplate. **Be careful not to damage the foam seal while removing the blower.**

BLOWER LEADS

BLOWER MOTOR MOUNTING SCREWS (4)



SHROUD

FOAM SEAL

6858-4

Figure 5-10 Blower Motor Removal

5.3.6.2 Blower Replacement

1. Secure the blower and shroud to the baseplate with the previously removed hardware.
2. Connect the blower leads to TB4.
3. Replace the top and bottom covers.
4. Slide the drive into the rack and connect the ac line cord.
5. Close the rear door.

5.3.7 Power Supply Removal

Close tolerances between the power supply package, the baseplate assembly, and the chassis may make it necessary to remove the frontmost (+15 Vdc) regulator before removing the RK05 power supply and assembly. The procedure is as follows:

1. Loosen the two captive screws that hold the frontmost regulator in place.
2. Remove that regulator.
3. There should now be enough room to remove the power supply.

5.3.8 Cartridge Cleaning

Professional cartridge cleaning is recommended wherever practicable. However, it may occasionally become necessary for qualified DEC Field Service personnel to clean cartridges in a troubleshooting or emergency maintenance situation. Application of this procedure by unqualified personnel will void warranty on that cartridge and on any drive in which that cartridge is operated.

5.3.8.1 Cartridge Cleaning Procedure

1. Lay the cartridge bottom up on a clean, hard surface, such as a cleared desktop or table. In this position the cartridge will tend to be somewhat unstable and may require support.
2. Remove the screws that hold the cartridge top and bottom plastics together, using only enough downward force on the screwdriver to hold it in the screwhead. Excessive force can strip the threads of the plastic.
3. Pick up the disk by the hub, being careful not to hit the access door with the edge of the disk when lifting it out of the cartridge.

CAUTION

Do not loosen the four screws in the hub holding the clamping ring and filter ring to the disk; this would permit the disk (and data) to move in relation to the centering cone of the hub, which would cause the data to become unrecoverable.

4. Inspect the oxide surface of the disk for the following:
 - a. "Comet tail" scratches – ding marks with tapering scratches caused by particles embedded in the disk and then knocked out.

- b. "Full circle" scratches – scratches caused by particles that remain stuck to the heads. This condition requires that the heads be cleaned.
- c. Single spot marks, dings, or scratches, with no associated circular scratches – usually the result of dimples or bumps on the disk, or of the air inlet door being pushed into the surface of the disk.
- d. Black (burned) or dark brown streaks of oxide.
- e. Fingerprints.

NOTE

A large number of small, shiny streaks all over a well-used disk is evidence of normal head/disk interference.

- 5. Inspect the hub for the following:
 - a. Bent, nicked, or dirty sector slots in the sector ring.
 - b. Bent, nicked, or dirty mating cone or mating ring-plate.
- 6. Inspect the top plastic for the following:
 - a. Broken clear plastic seal on the access door.
 - b. Retaining button that retracts when the access door is opened.
 - c. Worn retaining button in center of the top.
 - d. Properly closing access door.
 - e. Signs of rubbing by the disk.
 - f. Spring load on the retaining button.
- 7. Inspect the bottom plastic for the following:
 - a. Broken rivets on the air inlet door.
 - b. Signs of rubbing by the disk.
 - c. Fingerprints on the air inlet door.
- 8. Lay the disk on a spread-out Kimwipe on a desk or tabletop. Press down on the hub with one hand to prevent the disk from tipping. With the other hand, wipe the surface of the disk with a Texpad or Kimwipe soaked in 91% isopropyl alcohol. Wipe with small circular motions around the circumference of the disk.

CAUTION

Use only 91% isopropyl alcohol for this purpose. Water, trichloroethylene, and other solvents will attack the epoxy binder of the oxide.

9. Wipe the disk dry with a dry Kimwipe *before* the alcohol evaporates. If the alcohol is permitted to evaporate by itself, residue spots on the oxide will result. If it is necessary to rub an individual shiny spot or streak on the oxide, it should be done very gently; the surface of the disk could be bent by pressing down too hard.
10. Turn the disk over, holding it by the hub only. Do not handle the disk by its edges; this results in the deposit of finger oils that could be transferred to the oxide surface by further wiping.

CAUTION

Dry lint may be blown off gently by mouth. Do not spit on the disk. Do not use ordinary plant air, which may contain an unacceptable level of water or oil; canned air, however, is generally acceptable.

11. Wipe off the inside and outside of both the top and bottom plastics, taking care not to leave any lint. Remove any portions of the clear plastic door seal that may break off during use of the cartridge.
12. Reassemble the cartridge. Locate the original threads in the top plastic screw holes by rotating the screw *backward* one or two revolutions before driving it. Use a minimum of downward force on the screwdriver to avoid damaging the plastic threads and creating plastic chips inside the cartridge.

5.3.8.2 Adverse Disk Conditions – The disk will probably cause damage to the heads if used in the following conditions:

1. The center retaining button shows signs of rubbing on the hub cone of the disk. This creates particles inside the cartridge during operation and allows the disk to rattle around inside the cartridge during handling.
2. The air inlet door is loose, or has broken rivets.
3. There are signs of disk rubbing on the insides of the cartridge.
4. The disk has nonremovable scratches or dings which stick up above the smooth oxide surface.
5. The disk causes continual tinging sounds after the usual single short ting that accompanies loading.
6. The disk continually deposits oxide on the heads.

CAUTION

If known good disks deposit oxide on the heads, the heads themselves may be at fault.

7. The disk has a hard and locatable error.

Cartridges displaying the above conditions can probably be used once more, if necessary, to recover critical data, but should be refurbished immediately thereafter, lest the heads crash and get destroyed.

Disks have been known to transfer data reliably despite having aluminum exposed through the oxide; conversely, disks have been known to crash heads despite having no visible scratches. The ultimate test of an acceptable disk must be whether it transfers data reliably while leaving the heads clean.

5.4 ALIGNMENT, CHECKS, AND ADJUSTMENTS

5.4.1 Alignment Cartridges

5.4.1.1 RK05K-AC Alignment Cartridge – This Digital Equipment Corporation alignment cartridge is preferred for RK05 and RK05-J alignment procedures. It provides three tracks (principal track 105, plus spare tracks 85 and 125) of constant frequency data and alternate sectors recorded at displacements of +0.0025 and -0.0025 inches, respectively, from the ideal track locations. Figure 5-11 shows how to read the vernier when locating the desired track.

To determine the vernier scale reading:

1. Take the whole number value of the nearest positioner track scale marking to the *right* of the vernier scale triangle (▲).
2. Take the value of the vernier scale marking that aligns perfectly with a positioner track scale marking.
3. Add these two values to find the vernier reading.

In Figure 5-11, the nearest positioner track scale marking to the right of the triangle is 100; the vernier scale value that aligns perfectly with a positioner track scale marking is 5. Therefore, the vernier is set to Track 105 ($100 + 5$).

When a head is aligned to specifications, the readback signal shows equal amplitudes for both sectors (shown when the oscilloscope displays only two sectors, and triggered by the SECTOR signal). The degree of amplitude inequality in alternating sectors indicates the departure from exact alignment.

Sector timing data is included on all three tracks to indicate head gap location relative to sector pulse detection. This data is represented by a single pulse (70 μ s nominal) triggered by the INDEX pulse 10 μ s prior to the onset of head alignment data.

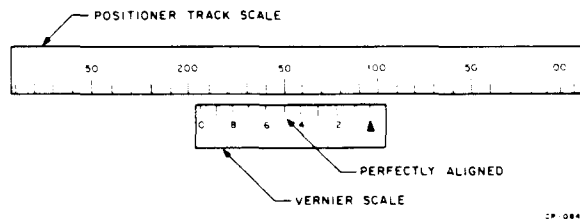

Figure 5-11 How to Read a Vernier

The RK05K-AC alignment cartridge also indicates the degree of runout on the spindle. When the oscilloscope is triggered on INDEX and a complete revolution of the disk is displayed, the head may appear to be aligned at some sector locations and misaligned at others. This condition indicates the degree of wobble of the spindle. Figure 5-12 shows a display with negligible runout; Figure 5-13 shows a spindle with considerable runout. The amount of wobble can be determined by the amplitude differences occurring in any adjacent pair of sector boundaries using the same equations used for head alignment.

NOTE

If the condition shown in Figure 5-13 exists, ensure that the mating of spindle and disk is clean. Improper mating can cause such runout.

Specifications for the RK05K-AC alignment cartridge when used with the RK05 and RK05-J are as follows:

Alignment and Sector Timing Tracks – primary track – 105; backup tracks – 85, 125, (use only if track 105 is unusable)

Recorded Frequency – nominal 720 kHz

Number of Sectors – 12

Alignment Accuracy, track 105 – ± 200 microinches

Sector Timing – single pulse $70 \pm 12 \mu s$ following INDEX pulse.

The RK05-AC alignment cartridge can be adapted for use by the RK05-F Disk Drive. To select the odd drive, ground A08K2 or A08M2. Only RK05-J track 105 may be used as an alignment track for the RK05-F. (This is because the 0.005053-inch center-to-center spacing of the RK05-F tracks will not divide evenly into the 0.010-inch center-to-center spacing of the RK05 and RK05-J tracks.)

RK05-J Tracks	RK05-F Tracks
85	
105	Odd drive 5
125	

5.4.1.2 2315 CE Test Cartridge Shim Installation – (To be used *only* when an RK05-AC alignment cartridge is not available.) Before a 2315 test cartridge can be used for any RK05 alignment procedure, a 0.005-inch shim must be installed in the disk hub. Because the 2315 cartridge is recorded at low density and the RK05 uses a high-density cartridge, this shim is required to accentuate the wobble of the low-density cartridge and allow it to be used for high-density alignments. To install the shim properly, trim a piece of 0.005-inch shim stock, as indicated in Figure 5-14, and attach it to the disk hub as follows:

1. Locate sector 00 by holding the cartridge upside down and observing the sector slots in the metal lip of the disk hub. Rotate the disk clockwise inside the plastic case until two slots close together are located (sector 11 and index slots). Continue to rotate the disk clockwise, stopping at the next slot (sector 00).
2. Position the shim 180 degrees from the sector 00 slot. Ensure that the narrow portion of the shim is in the spindle cavity and that the shim does not reach the bottom of the cavity.
3. Tape the shim in position.

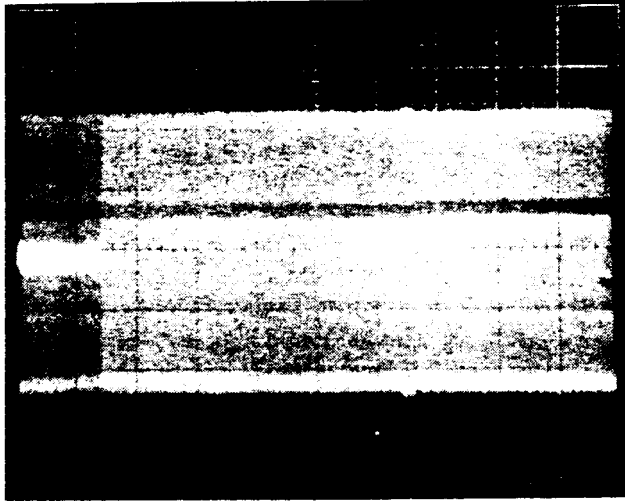
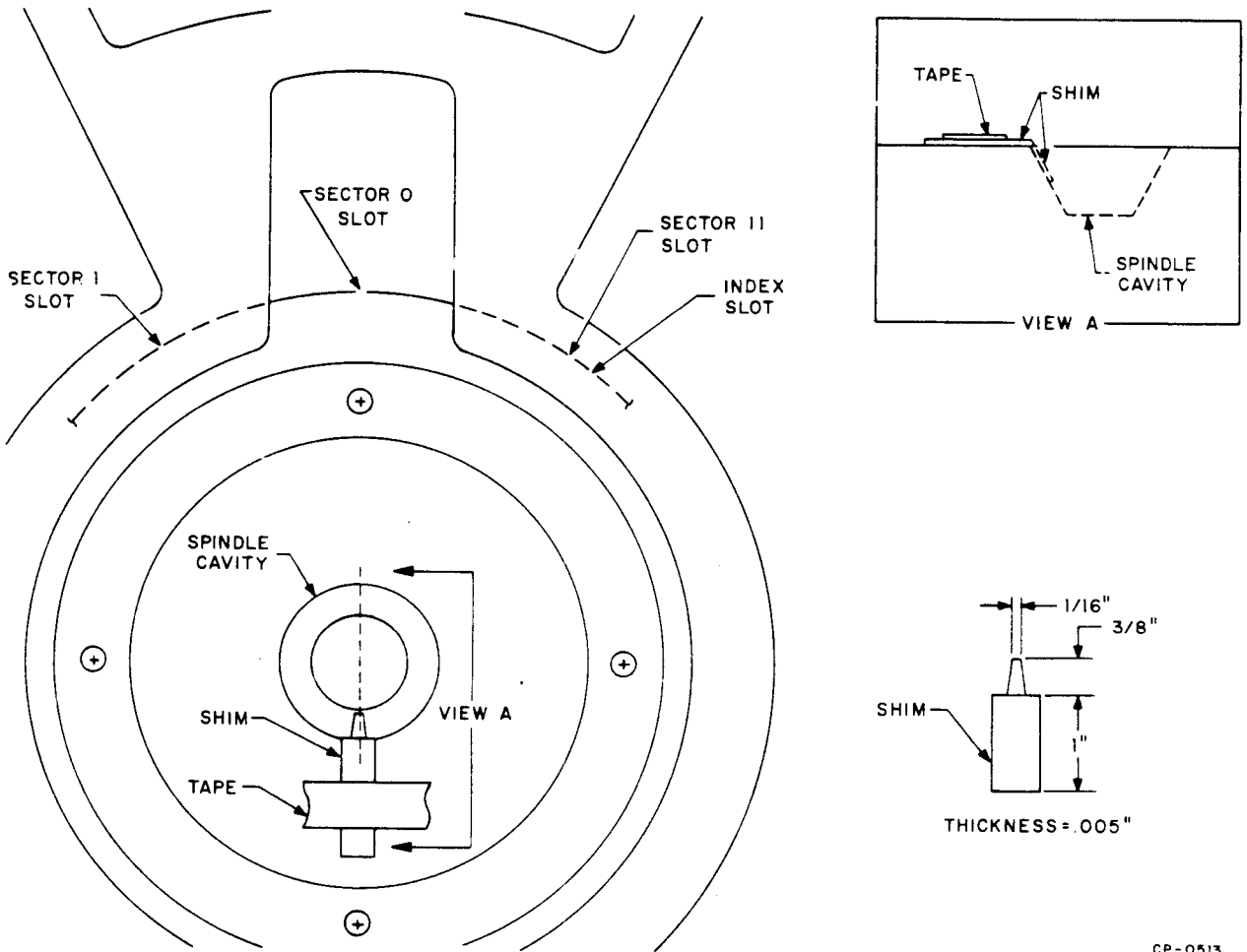

Figure 5-12 Negligible Runout



Figure 5-13 Considerable Runout



CP-0513

Figure 5-14 CE Test Cartridge Shim Installation

5.4.2 Servo System Timing Checks and Adjustments

The servo system timing adjustments are precisely set at the factory and should *not* be routinely adjusted or fine tuned as part of any PM procedure. If a positioner malfunction is suspected, all waveforms related to each phase of servo operation should be examined; based on these, the possible trouble should be diagnosed before any servo adjustments are attempted. Because some of the servo check tolerances differ from the adjustment tolerances, reference should be made to the check tolerances in Table 5-3 before adjustments are attempted.

NOTE

Settings within the tolerances listed in Table 5-3 should NOT be adjusted.

Table 5-3 Servo System Checks

Checks	Drive Configuration	Test Point	Tolerance	Reference
Sine Amplitude/Offset	4 cyl osc seek	A05M1	10 ± 1 V p-p, ground symmetrical within ±10%	Fig. 5-15
Velocity Offset	4 cyl osc seek	A05M1	ground symmetrical within ±10%	Fig. 5-15
Cosine Amplitude	4 cyl osc seek	A05S1	10 ± 1 V p-p, ground symmetrical within ±10%	Fig. 5-16
Velocity Amplitude (RK05/RK05-J) (RK05-F)	2 cyl osc seek	A05M1	center pulse duration = 3.2 ± 0.05 ms = 2.3 ± 0.1 ms	Fig. 5-17
Acceleration (RK05/RK05-J) (RK05-F)	64 cyl osc seek 128 cyl osc seek	A05H1	14 ms ± 1 ms rise time 13 ms ± 1 ms rise time	Fig. 5-18
Full Stroke Profile (RK05/RK05-J) (logical disk) (RK05-F)	202 cyl osc seek	A05H1	<90 ms waveform duration with plateau at trailing edge. <70 ms waveform	Fig. 5-19
Full Stroke Position (logical disk)	202 cyl osc seek	A05M1	equal beginning and end amplitudes within 5%. <1 V overshoot	Fig. 5-20
Outer Limit	rep RTZ	A05J1	3 to 3.5 V amplitude <0.3 V plateau	Fig. 5-21

For most malfunction cases, the positioner system will operate enough to allow dynamic measurements. However, if the positioner either does not operate or operates very erratically, the static checks and adjustments described in Paragraph 5.4.2.2 should be performed.

If servo system parts are field-installed, settings must be readjusted according to Table 5-3.

5.4.2.1 Dynamic Off-Line Checks and Adjustments – If on-line diagnostics or an RK05 Exerciser are not available to exercise the positioner, the RK05 should be disconnected from the interface bus and operated off-line.

In this mode, SECTOR pulses are jumpered to simulate STROBE pulses, and a SECTOR ADDRESS line is jumpered to provide changing inputs to selected CYLINDER ADDRESS lines. These jumper installations permit oscillating seeks between cylinder 00 and any selected cylinder to be performed.

The procedure for operating the drive off-line is as follows:

1. Unplug the drive ac line cord to remove power.
2. Install an M930 terminator card in position 7 or 8 of the electronic module.
3. Set the address select switch on the M7680/M7700 card (position 2) to the first switch position.
4. Select the drive by connecting a jumper from A08T1 (ground) to A08J2 (switch position 1).
5. Reconnect the ac line cord to apply power to the drive and cycle the drive up to operating status.
6. Perform an off-line oscillating seek with the jumpers as follows:

It is also possible to perform the following adjustments using the RK05-TA Exerciser or simple test programs. For additional information, refer to the RK05 Exerciser Maintenance Manual, (DEC-00-HZRKA-A-D).

- a. Connect a jumper from B08H1 (STROBE) to B08N2 (BUS SECTOR PULSE).
- b. Determine the seek length by connecting A08P2 (SECTOR ADDRESS) to the desired points indicated in the following table.

Seek Length	Jumper Connections
2	A08D1
4	A08L1
64	A08E1
100	A08E1, A08J1, A08L1
105	A08E1, A08J1, A08C1, A08K1
128	A08H1
202	A08H1, A08E1, A08C1, A08D1
Restore (RTZ)*	A08M1 (RESTORE) to A07T1 (or any available ground) B08H1 (STROBE) to B08M1 (INDEX)

*Connect only the points listed in the table.

7. Unless otherwise indicated, set the oscilloscope controls (Tektronix 453 or equivalent) as follows:

vertical

mode = channel 1
sensitivity = 2 V/div
trigger = channel 1
coupling = dc

sweep

A sweep time = 10 ms/div
trigger = normal

trigger

source = externals*
coupling = ac
slope = +

*Connect the scope external trigger input to B05J2 (FWD H).

8. To avoid excessive scope control changes and to keep the probe test point changes to a minimum, perform the following checks and adjustments in the listed sequence.

Sine Amplitude (SA) and Offset (SO)

- a. Perform a 4-cylinder oscillating seek (Step 6).
- b. Observe A05M1 (SIN POSITION) for a scope display similar to that shown in Figure 5-15a. The waveform amplitude must be 10 ± 1 V peak-to-peak and symmetrical about ground.
- c. If necessary, adjust SA (Table 5-4) for the correct amplitude and SO for the ground symmetry.

Velocity Offset (VO)

- a. Perform a 4-cylinder oscillating seek (Step 6).
- b. Observe that the voltage minimums at A05M1 (SIN POSITION) are symmetrical about ground (Figures 5-15a and 5-15b). A small amount of ripple at the minimum voltage levels is normal. To estimate the degree of symmetry, use the average value of the ripple as the voltage minimum.
- c. If necessary, adjust VO (Table 5-4) for the required symmetry.

Cosine Amplitude (CA) and Offset (CO)

- a. Perform a 4-cylinder oscillating seek (Step 6).
- b. Observe A05S1 (COS POSITION) for a scope display as shown in Figure 5-16. The waveform amplitude must be 10 ± 1 V peak-to-peak, and symmetrical about ground.
- c. If necessary, adjust CA (Table 5-4) for the correct amplitude and CO for the ground symmetry.

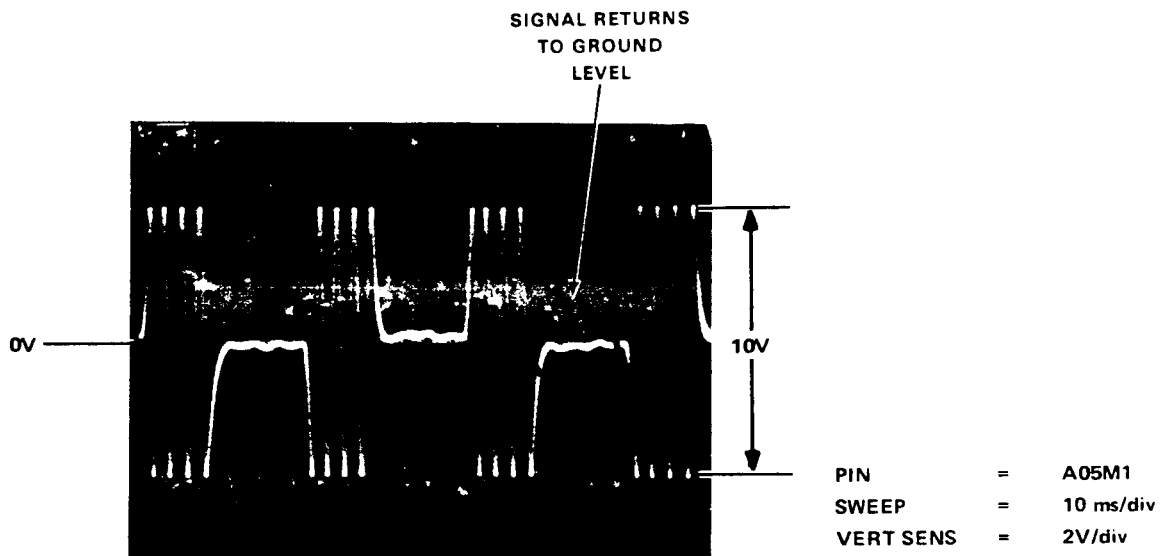

(a) Correct Waveform (Symmetrical Signal)

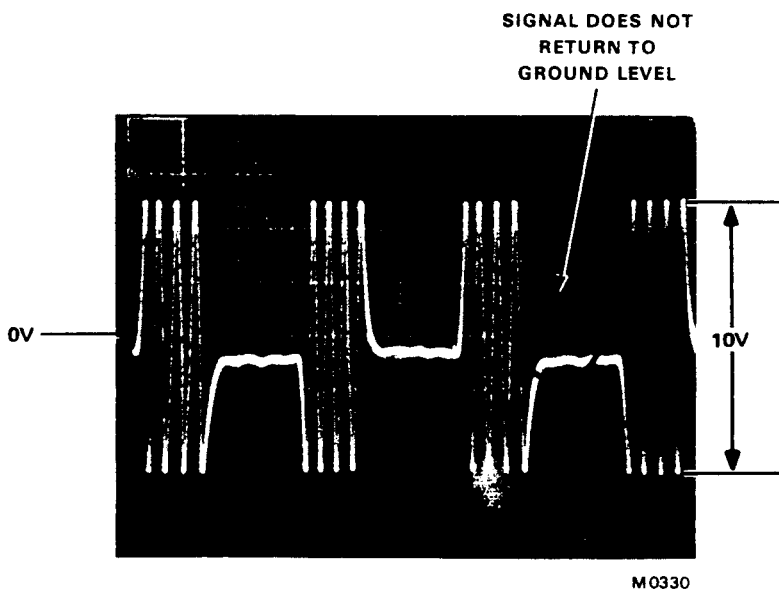

(b) Incorrect Waveform (Signal not Symmetrical about Ground)

Figure 5-15 Sine Amplitude/Offset and Velocity Offset Waveform

Table 5-4 Servo System Adjustments

Potentiometer*	Function
CA (Cosine Amplitude)	Sets amplitude of COS POSITION signal.
CO (Cosine Offset)	Adjusts COS POSITION symmetry about ground.
SA (Sine Amplitude)	Sets amplitude of SIN POSITION signal.
SO (Sine Offset)	Adjusts SIN POSITION symmetry about ground.
LSA (Limit Signal Amplitude)	Simultaneously adjusts amplitude of both Limit signals before digitizing.
LSO (Limit Signal Offset)	Sets zero level of Limit signal with positioner in normal recording area of disk.
VA (Velocity Adjustment)	Calibrates velocity generator.
VO (Velocity Offset)	Adjusts velocity generator output at zero velocity. (Provides offset control to position loop.)
CURRENT (on H604)	Sets maximum positioner current (determines acceleration).

*Potentiometers are located on the G938/G938YA card (position 5) of the logic assembly; access is obtained by removing the prefilter. They are listed in the table according to their physical orientation; CA is the topmost potentiometer as viewed from the rear of the drive with the prefilter removed.

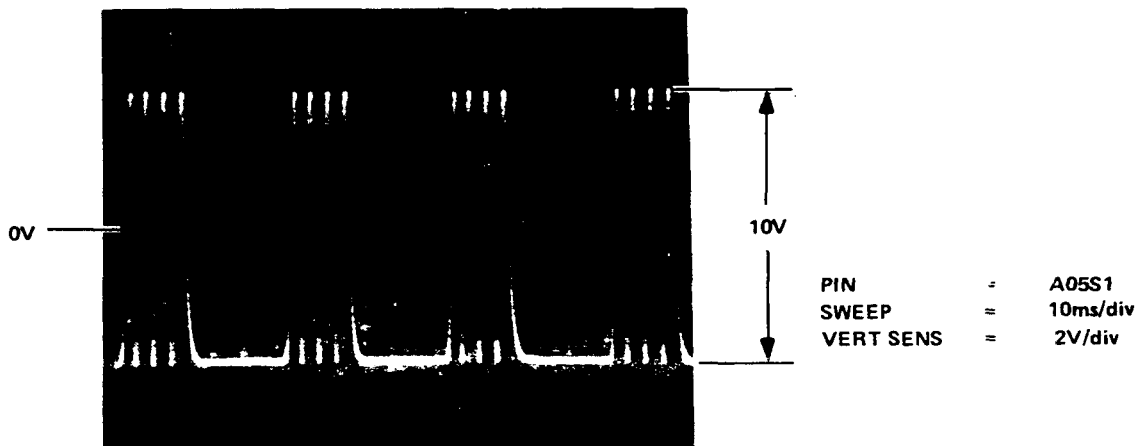

Figure 5-16 Cosine Amplitude/Offset Waveform

Velocity Amplitude (VA)

- a. Perform a 2-cylinder oscillating seek (Step 6).
- b. Set the scope sweep time to 1 ms/div.
- c. Observe A05M1 for a scope display as illustrated in Figure 5-17. The duration of the center cycle must equal 3.2 ± 0.05 ms (2.3 ± 0.1 ms for the RK05-F).
- d. If necessary, adjust VA (Table 5-4) for the correct time.

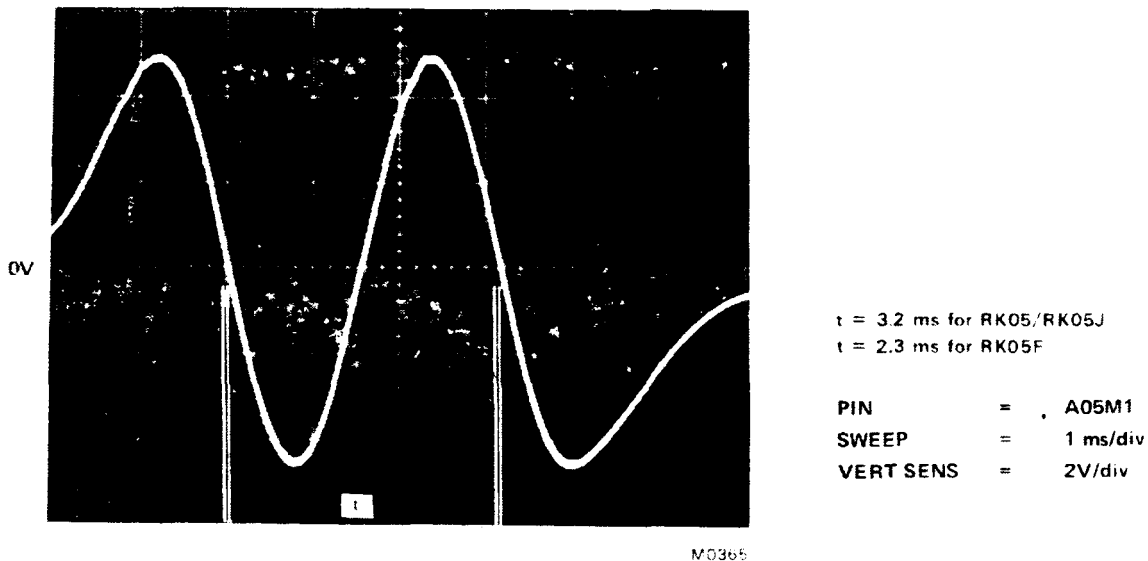

Figure 5-17 Velocity Amplitude Waveform

Acceleration (Positioner Current)

- a. Perform a 64-cylinder oscillating seek (Step 6) (128-cylinder for RK05-F).
- b. Set the scope sweep time to 5 ms/div and the vertical sensitivity to 0.5 V/div.
- c. Observe A05H1 (VELOCITY) for a velocity profile as shown in Figure 5-18.
- d. If necessary, adjust R15 (on H604) for a rise time of $14 \text{ ms} \pm 1 \text{ ms}$ ($13 \pm 1 \text{ ms}$ for RK05-F).

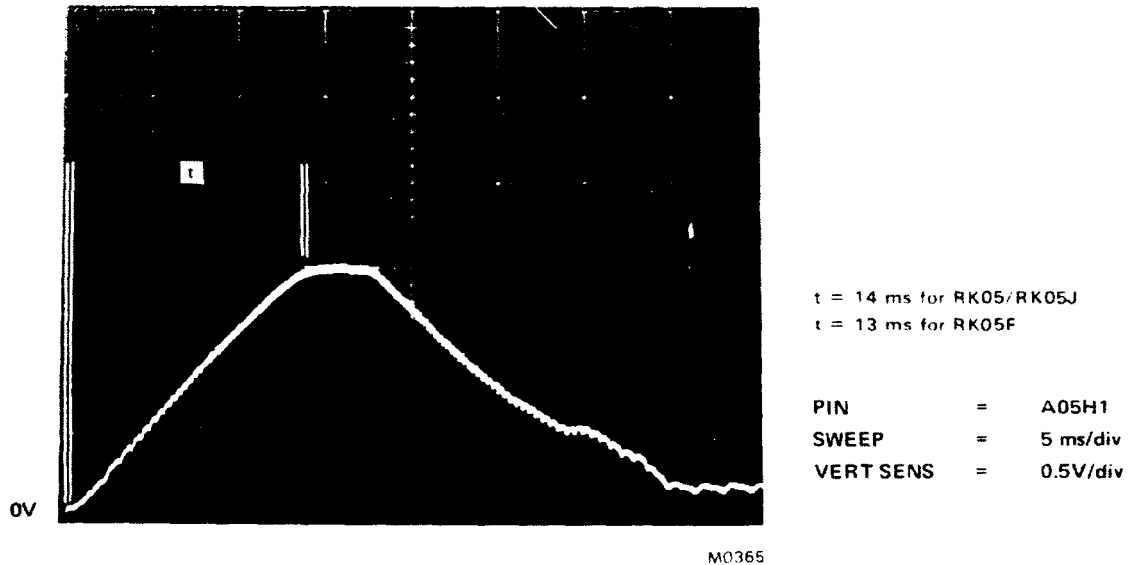

Figure 5-18 Acceleration Waveform

Full Stroke Profile

- a. Perform a 202-cylinder oscillating seek (Step 6).
- b. Set the scope sweep time to 10 ms/div and the vertical sensitivity to 0.5 V/div.
- c. Observe A05H1 (VELOCITY) for a scope display as illustrated in Figure 5-19. The 0 V level of the profile must be reached in less than 90 ms from the start of the seek (70 ms for RK05-F).

In addition, there must be a definite plateau (constant voltage level) at the end of the seek. If this is not the case, recheck the VA and the Acceleration (Positioner Current). Adjust the appropriate potentiometer (Table 5-4) as required to obtain the correct waveform.

Full Stroke Position Waveform

- a. Maintain the same configuration as for the Full Stroke Profile.
- b. Set the scope vertical sensitivity to 2 V/div and observe A05M1 (SIN POSITION) for a scope display as illustrated in Figure 5-20. The waveform amplitudes at the start and end of the seek must be equal within 5%, and the overshoot at the end of the seek must not exceed 1 V. If overshoot is excessive, recheck the VA and the Acceleration (Positioner Current).

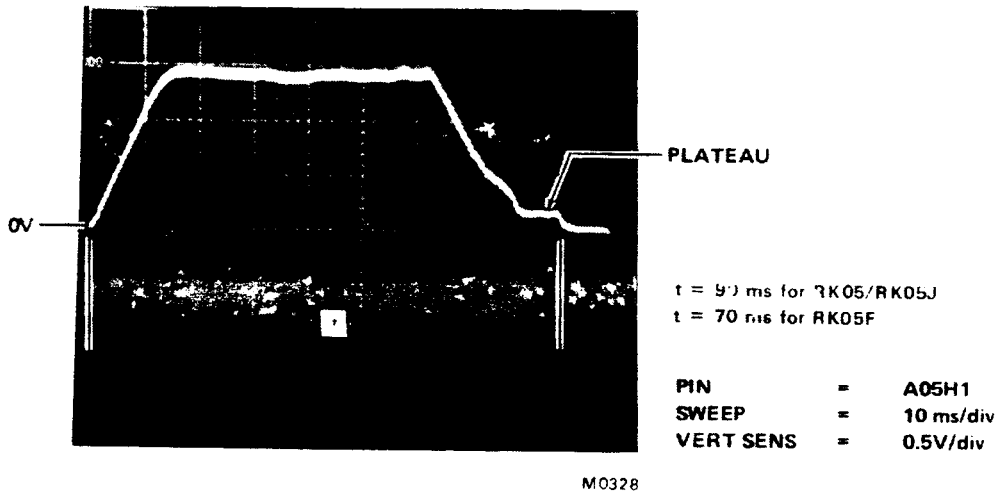

Figure 5-19 Full Stroke Waveform

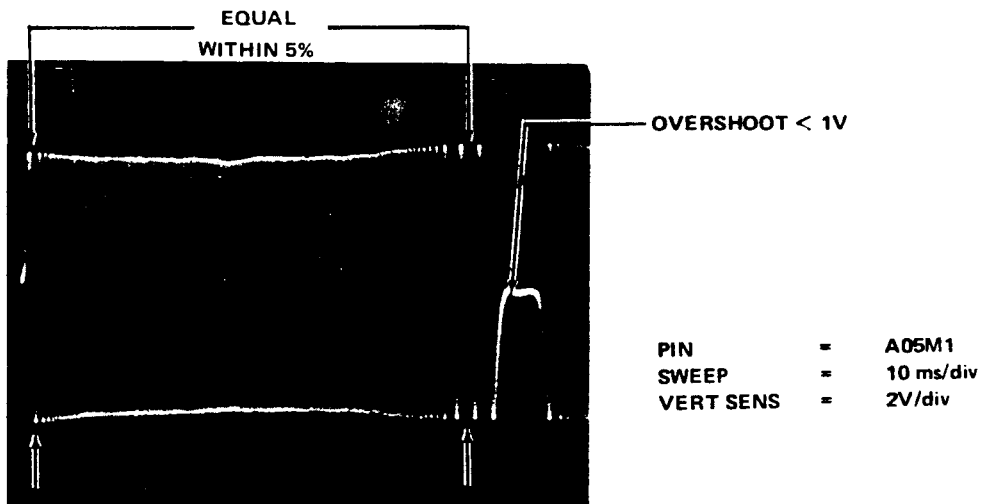

Figure 5-20 Full Stroke Position Waveform

Outer Limit (Dynamic Test)

- a. Perform a repetitive restore operation (Step 6).
- b. Trigger the scope from B05K2 (REV H).
- c. Set the scope vertical sensitivity to 1 V/div and observe A05J1 (LIMIT) for a scope display as illustrated in Figure 5-21. The waveform peak amplitude must be 3 to 3.5 V with a minimum level of 0 V. In addition, the voltage plateau immediately following the trailing edge must not exceed 0.3 V. If not, perform the static limit adjustment procedure (Paragraph 5.4.2.2).
- d. Disconnect the B08H1 (STROBE) jumper to halt the repetitive restore.
- e. Check the INNER LIMIT signal by physically moving the positioner to the inner limit (toward the spindle). If the INNER LIMIT signal is operative, a restore operation will be initiated. If this is not the case, perform the static limit adjustment procedure (Paragraph 5.4.2.2).

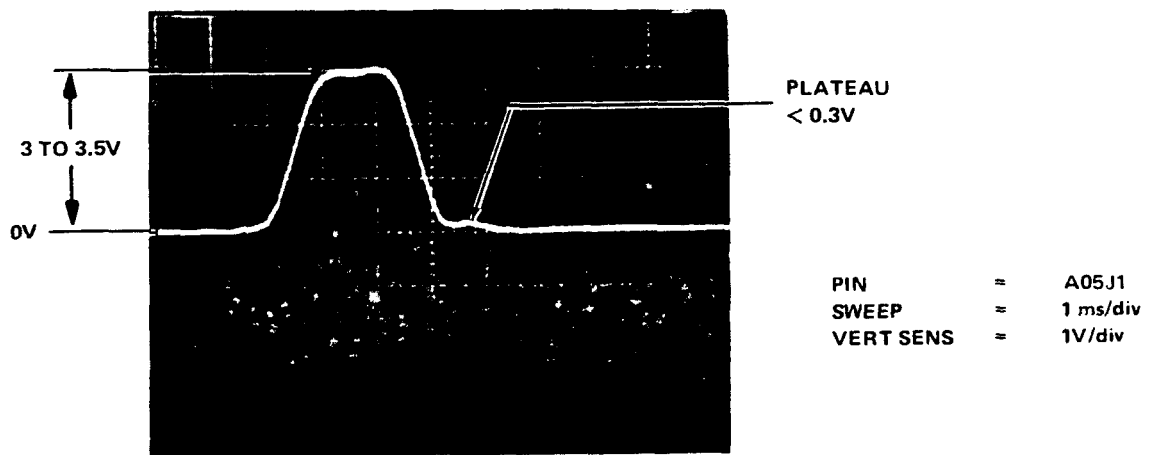

Figure 5-21 Outer Limit Waveform

5.4.2.2 Static Tests and Adjustments – The following procedure should be performed when the positioner or a major servo system component has been replaced. This procedure should also be followed as a diagnostic aid when the positioner system is inoperative or unstable in operation.

To make the required adjustments, remove the disk cartridge from the drive and physically move the positioner carriage back and forth while observing the selected signal. Use the automatic scope sweep and do not attempt to sync the sweep to the observed signal. With a little practice, the most convenient sweep speed setting and the type of positioner motion required will quickly be discovered.

To make static adjustments, the following procedure should be followed:

1. Do not install a disk cartridge in the drive.
2. Place a finger on the positioner carriage assembly and then place switch S1 (Figure 4-17) in the down or OFF position. (This precaution prevents any possible carriage motion caused by transient switch noise.)
3. Make the following checks and adjustments.

Sine Amplitude (SA) and Offset (SO)

- a. Set the scope vertical sensitivity to 2 V/div and adjust the ground reference to the center of the scope screen.
- b. Observe A05M1 (SIN POSITION) while manually moving the positioner back and forth. Adjust SA (Table 5-4) for a $10\text{ V} \pm 1\text{ V}$ peak-to-peak signal amplitude.
- c. Adjust SO until the signal is symmetrical about ground.

Cosine Amplitude (CA) and Offset (CO)

Observe A05S1 and adjust CA and CO (Table 5-4) in the same manner as that used in the Sine Amplitude and Offset procedure, above.

Limit Signal Amplitude (LSA) and Offset (LSO)

- a. Set the scope vertical sensitivity to 1 V/div and adjust the ground reference to the center of the scope screen.
- b. Observe A05J1 with the positioner stationary at approximately the center of travel. Adjust LSO (Table 5-4) for a ground signal at the center of the scope screen.
- c. Move the positioner to the inner limit and observe the voltage change on the scope. Similarly, move the positioner to the outer limit and observe the voltage change.
- d. Adjust LSA until the smaller voltage level obtained in Step c, above, is 3.0 V.
- e. Return the positioner to the center of travel and readjust LSO for 0 V.
- f. Repeat Step c, above; if necessary, readjust the smaller voltage level to 3.0 V.

5.4.3 Read/Write Data Separator (G180 Card) Adjustment

Adjustment of the data separator is not part of normal maintenance and is therefore not recommended unless a G180 component that affects the data separator section has been replaced. If this occurs, the width of the data window should be set as follows:

CAUTION

R13 is the write current adjustment potentiometer and cannot be adjusted in the field.

1. Install a prerecorded cartridge in the drive.

2. Place the drive in the run mode and manually position the heads at any recorded cylinder past track zero. An all-zero recording is preferable; however, any recorded pattern is sufficient.

NOTE

To position the heads manually, allow them to load under servo control; then place a finger on the carriage while opening the switch (S1) to preclude the possibility of carriage motion caused by the transient switch noise.

3. Set the oscilloscope controls as follows:

vertical
mode = channel 1
sensitivity = 1 V/div
trigger = channel 1
coupling = dc

sweep
A sweep time = 100 ns/div
trigger = normal

trigger
source = internal
coupling = ac
scope = +

4. Connect the channel 1 scope probe to TP1 of the G180 card (card position 1). It should be possible to obtain solid scope synchronization at the sweep start. (Disregard the unsynchronized pulses that follow.)
5. Adjust R55 fully counterclockwise and R54 fully clockwise.
6. Adjust R54 counterclockwise to obtain a 500 ± 40 ns pulse width as measured from the start of the rise to the start of the fall.
7. Readjust R55 clockwise until the pulse width decreases to 440 ± 10 ns as measured from the start of the rise to the start of the fall.

5.4.4 Read/Write Head Check and Alignment

The following procedure describes the complete read/write head alignment. Before attempting this alignment procedure, ensure that the drive operates correctly and that the heads have not been contaminated by exposure to a defective cartridge. If new heads have been installed, it is recommended that this alignment procedure be performed off-line using backboard jumpers to move the positioner to the alignment cylinder. Off-line alignment is strongly recommended because of the ease of returning to the alignment cylinder whenever the positioner has been physically moved. However, simple maintenance routines or an RK05 Exerciser may also be used to move the positioner.

5.4.4.1 RK05K-AC Alignment Cartridge – The appropriate on-line diagnostics may be used for head alignment; however, *do not adjust a head that has less than a 15% error* (Figure 5-22).

- a. Extreme misalignment. Head close to CYL 104. (Further misalignment only reduces amplitude of signal on right side of screen.)

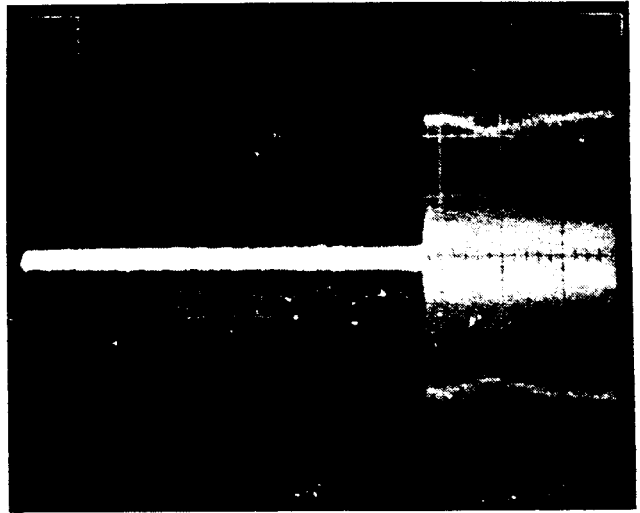

- b. Head considerably misaligned. Smaller left amplitude indicates head position less than CYL 105.

error = -72%

BRIGHT LINE SHOULD APPEAR HERE

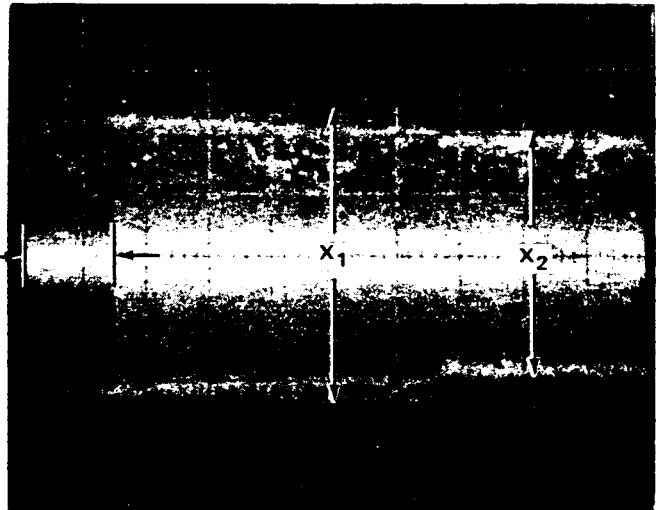

- c. Head slightly misaligned. Smaller left amplitude indicates head position less than CYL 105.

error = -15%

BRIGHT LINE SHOULD APPEAR HERE

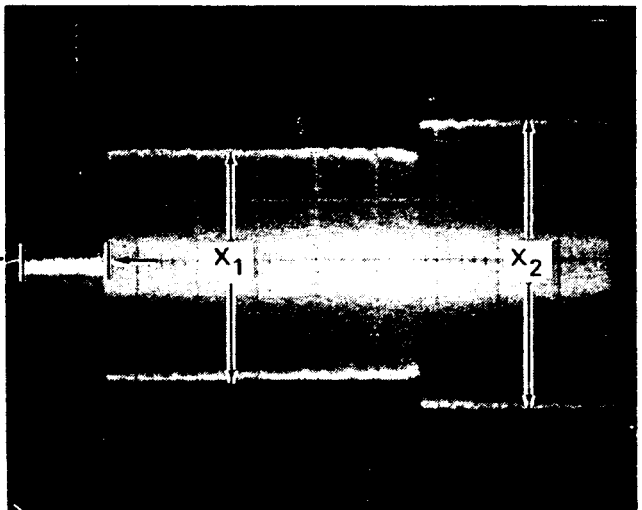
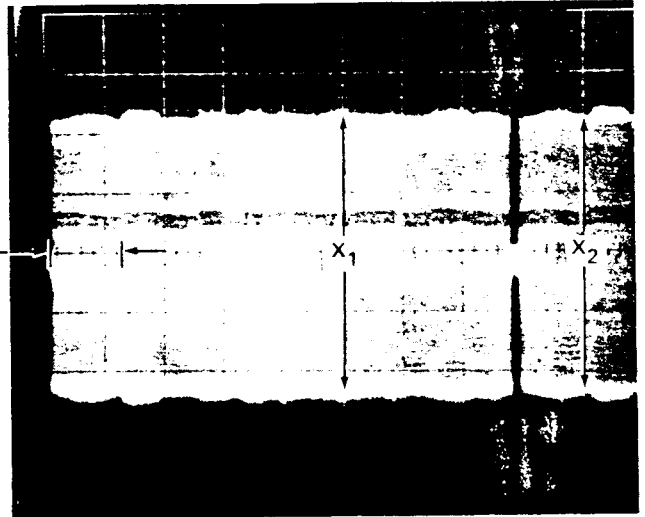

Figure 5-22 RK05K-AC Head Alignment Waveforms (Sheet 1 of 3)

- d. Head correctly aligned at CYL 105.
Amplitudes are equal.

BRIGHT LINE
SHOULD APPEAR
HERE



- e. Head slightly misaligned. Larger left amplitude indicates head position more than CYL 105.

$$\text{error} = +15\%$$

BRIGHT LINE
SHOULD APPEAR
HERE

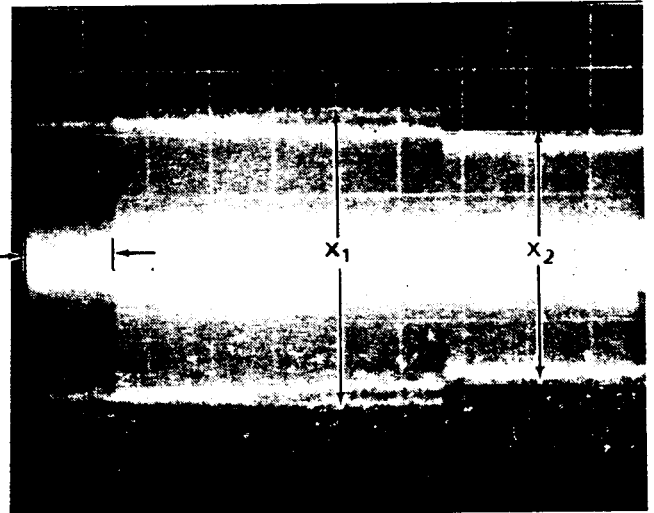

- f. Head considerably misaligned. Larger left amplitude indicates head position more than CYL 105.

$$\text{error} = +72\%$$

BRIGHT LINE
SHOULD APPEAR
HERE

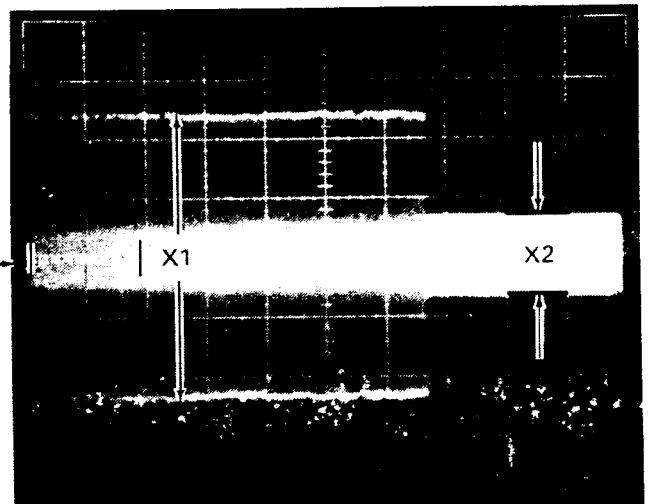
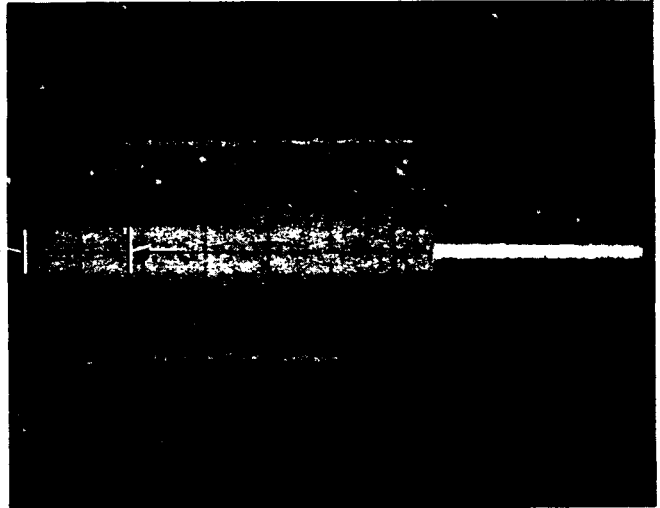

Figure 5-22 RK05K-AC Head Alignment Waveforms (Sheet 2 of 3)

BRIGHT LINE
SHOULD APPEAR
HERE



- g. **Extreme misalignment.** Head close to CYL 106. (Further misalignment only reduces amplitude of signal on left side of screen.)

To calculate % of error, use the following formula:

$$\% \text{ error} = \frac{x_1 - x_2}{x_1 + x_2} \times 100$$

x_1 and x_2 = amplitudes. The resultant sign denotes the direction of error; a negative (-) sign indicates that the head is back too far.

Figure 5-22 RK05K-AC Head Alignment Waveforms (Sheet 3 of 3)

To align or check the heads, proceed as follows:

1. Unplug the drive ac line cord to remove power.
2. Disconnect the drive interface cable card from the logic assembly and install in its place an M930 terminator card.
3. Reconnect the ac line cord to bring the drive up to operating status.
4. Install an alignment cartridge on the spindle and operate the drive in the run mode for *at least 30 minutes*. This must be done to allow the alignment cartridge and the drive components to achieve thermal stabilization.
5. Using the WT PROT switch, place the drive in the write protect condition.
6. Set the oscilloscope controls as follows:

vertical
mode = ADD (invert CHAN 2)
sensitivity = 20 mV/div
coupling = dc

sweep
A sweep time = 500 μ s/div
trigger = normal

trigger
source = external*
coupling = ac

***Important:** Use a 1:1 probe to connect the scope external trigger input to A02S2 (SECTOR).

7. Connect the channel 1 probe to TP3 and the channel 2 probe to TP4 of the G180 card. (Use 10:1 probes.)
8. Ensure that the positioner track scale indicates cylinder 00. If it does not, loosen and readjust the scale to read 00, ensuring proper scale readout over the entire length of the head. This is done as follows:
 - a. Load the heads.
 - b. Check whether the scale is set at zero; if not, loosen the scale retaining screws (Figure 5-23).
 - c. Adjust the fixed scale horizontally to read zero. Ensure that the calibrated edges of the fixed scale and the vernier scale are parallel and close together without touching. Tighten the scale retaining screws.
 - d. Push S1 (Figure 4-17) down, and move the vernier scale horizontally through its entire range to ensure that the calibrated edges of the two scales do not touch at any point.

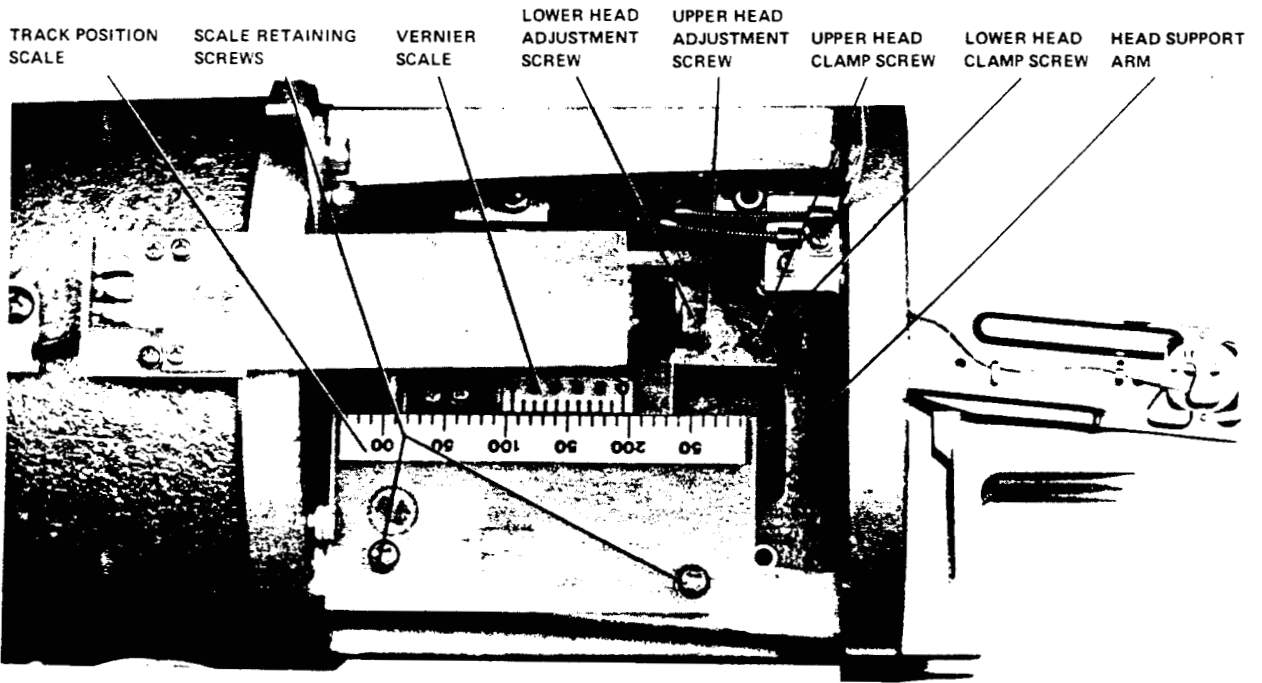

6858-5

(a)

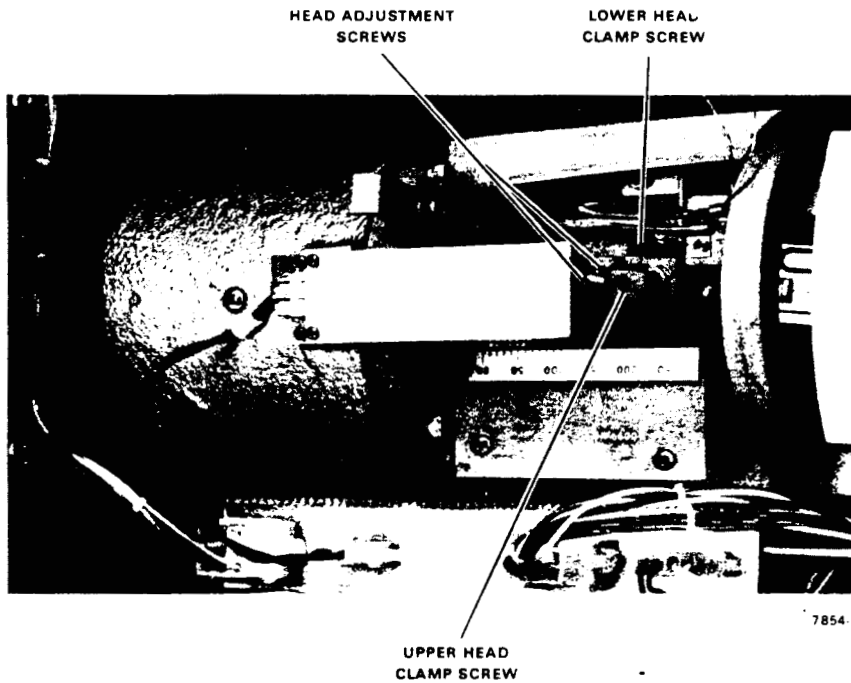

7854.2

(b)

Figure 5-23 Read/Write Head Adjustments

9. For the RK05 or RK05-J drives, select cylinder 105 as follows:

NOTE

It is also possible to perform the following adjustments using the RK05 Exerciser or simple maintenance routines. For additional information, refer to the RK05 Exerciser Maintenance Manual.

- a. Connect backboard jumpers from A07T1, A07C2, B07T1, or any available ground pins to the following points:

A08E1 CYL ADD 6(64)

A08J1 CYL ADD 5(32)

A08C1 CYL ADD 3(8)

A08K1 CYL ADD 0(1)
105

A04V1 SEL RDY L

- b. Connect a jumper from B08H1 (STROBE) to B08N2 (SECTOR PULSE). The positioner should move to cylinder 105. Confirm this by observing the track scale indicator.

For the RK05-F drive, select cylinder 5, odd drive, as follows:

- a. Connect backboard jumpers from A07T1, A07C2, B07T1, or any available ground pins to the following points:

A08K2 ODD DRIVE
A08M2

A08L1 CYL ADD 2(4)

A08K1 CYL ADD 0(1)
5

A04V1 SEL RDY L

- b. Connect a jumper from B08H1 (STROBE) to B08N2 (SECTOR PULSE). The positioner should move to cylinder 5. Confirm this by observing the track scale indicator.

10. Monitor the scope display for one of the waveforms illustrated in Figure 5-22.

NOTE

A bright horizontal line should appear at the beginning (left) of the displayed waveform, as shown in Figures 5-22b through 5-22g. If the line does not appear, adjust the scope level control until it does. This bright line indicates proper positioning of the sectors; odd sectors (X1) on the left, even sectors (X2) on the right.

If none of the illustrated waveforms appear, the head is so badly misaligned that manual manipulation of the positioner is required. If manual manipulation is required, perform the steps that follow; if not, proceed to Step 11.

- a. Place switch S1 (Figure 4-17) in the down or OFF position, keeping a finger on the carriage while manipulating the switch to dampen any positioner transients.
- b. Slowly move the positioner by hand until the alignment pattern occurs. Cylinders 85 and 125 have identical patterns, so be sure that the displayed pattern is for cylinder 105 (5 for the RK05-F). Do not use undue force on the positioner when manually changing track positions.
- c. Observe the track scale and note the cylinder indication when the correct waveform (Figure 5-22d) is obtained. If the scale indicates less than 105 (5 for the RK05-F), the head is too far forward in the carriage. Conversely, if the scale indicates more than 105 (5 for the RK05-F), the head is too far back in the carriage.
- d. Loosen the clamp and adjustment screws (Figure 5-22) and move the head in the appropriate direction until the correct waveform (Figure 5-22d) is obtained and the scale indication is slightly greater than 105 (5 for the RK05-F Disk Drive).

Tightening the clamp screw firmly will cause the head to move forward slightly, bringing the scale indication to 105 (5 for the RK05-F).

- e. Lightly tighten the clamp screw and turn on the positioner power (S1 up).
 - f. After turning off positioner power, move the positioner fully forward. Turn on positioner power (S1 up) to initiate a restore (RTZ) operation. The positioner will automatically return to cylinder 105 following the RTZ (cylinder 5 for RK05-F).
11. If one of the illustrated waveforms is present, note in which direction the head must be moved to obtain the correct indication (Figure 5-22d). If it must be moved backward, loosen the head clamp and adjustment screws and gently push the head all the way back into the carriage; if it must be moved forward, loosen only the clamp screw, and then turn the adjustment screw until the correct waveform is obtained.

The adjustment screw is a vernier that only moves the head forward; it should not be left torqued down after this adjustment.

NOTE

If the positioner is moved from cylinder 105 (or 5) during the adjustment procedure, turn off positioner power (S1 down) and manually move the positioner fully forward. Then turn on positioner power (S1 up) to initiate a restore (RTZ) operation. The positioner will automatically return to cylinder 105 following the RTZ (cylinder 5 for RK05-F).

12. Ground B08M2 to select the upper head and repeat the preceding steps.
13. Using the appropriate torque wrench (Paragraph 5.3.3.1), tighten the head clamp screw until the wrench begins to ratchet. If a torque wrench is not available, use the appropriate Allen wrench to tighten the head clamp screw snugly; do not overtighten.
14. Recheck to ensure that the clamping action did not disturb the head adjustment.

5.4.4.2 2315 CE Pack – The appropriate on-line diagnostics may be used for head alignment; however, *do not adjust a head that has less than a 15% error* (Figure 5-24).

To align or check the heads proceed as follows:

NOTE

Do NOT use this procedure with the DEC RK05K-AC Alignment Cartridge; use the procedure from Paragraph 5.4.4.1.

1. Unplug the drive ac line cord to remove power.
2. Disconnect the drive interface cable card from the logic assembly and install an M930 terminator card in its place.
3. Reconnect the ac line cord to apply power to the drive and cycle the drive up to operating status.
4. Install a 2315 CE test cartridge on the spindle and operate the drive in the run mode for *at least 30 minutes*. This must be done to allow the CE cartridge and the drive components to achieve thermal stabilization.
5. Using the WT PROT switch, place the drive in the write protect condition.
6. Set the oscilloscope controls as follows:

vertical
mode = ADD (invert CHAN 2)
sensitivity = 20 mV/div
coupling = dc

sweep
A sweep time = 10 ms/div
trigger = normal

trigger
source = external*
coupling = ac

***Important:** Use a 1:1 probe to connect the scope external trigger input to A02R2 (INDEX).

7. Connect the channel 1 probe to TP3 and the channel 2 probe to TP4 of the G180 card. (Use 10:1 probe.)
8. Ensure that the positioner track scale indicates cylinder 00. If it does not, loosen and readjust the scale to read 00, ensuring proper scale readout over the entire length of the head. This is done as follows:
 - a. Load the heads.
 - b. Check whether the scale is set at zero; if not, loosen the scale retaining screws (Figure 5-23).

- a. Extreme misalignment. Head close to CYL 104. (Further misalignment only reduces amplitude of peaks.)

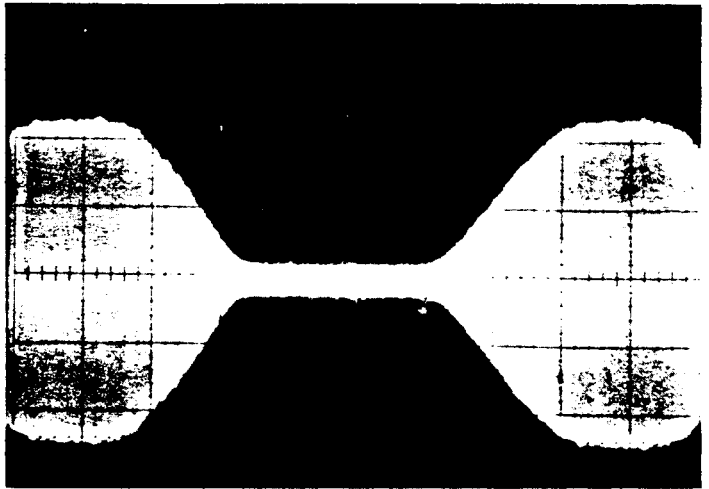

- b. Head considerably misaligned. Smaller left null indicates head position less than CYL 105.

error = -60%

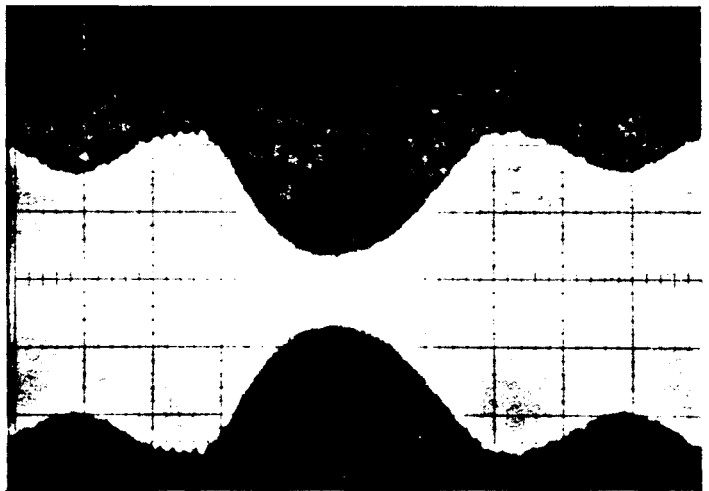

- c. Head slightly misaligned. Smaller left null indicates head position less than CYL 105.

error = -33%

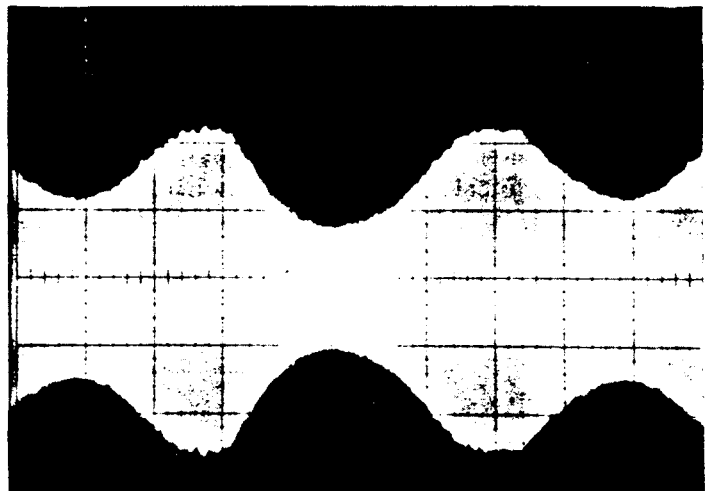
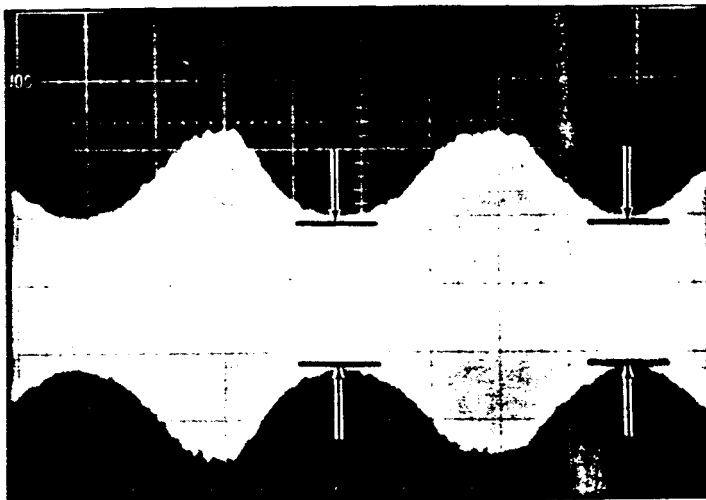

Figure 5-24 2315 CE Pack Head Alignment Waveforms (Sheet 1 of 3)

- d. Head correctly aligned at CYL 105. Null amplitudes are equal.



- e. Head slightly misaligned. Larger left null indicates head position more than CYL 105.

error = +26%

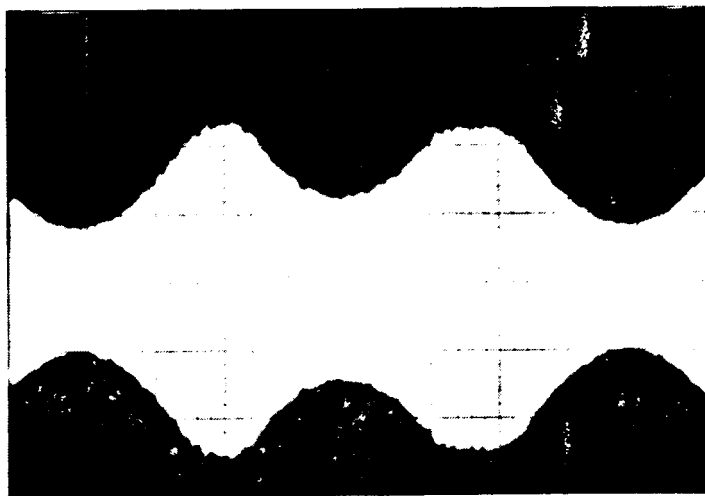

- f. Head considerably misaligned. Larger left null indicates head position more than CYL 105.

error = +71%

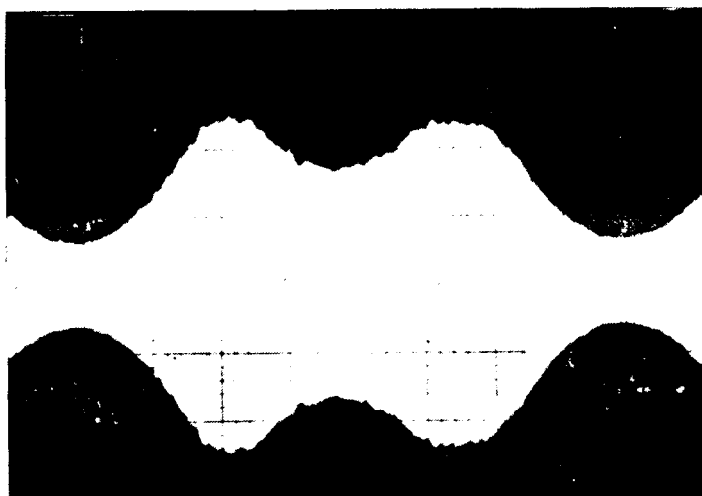
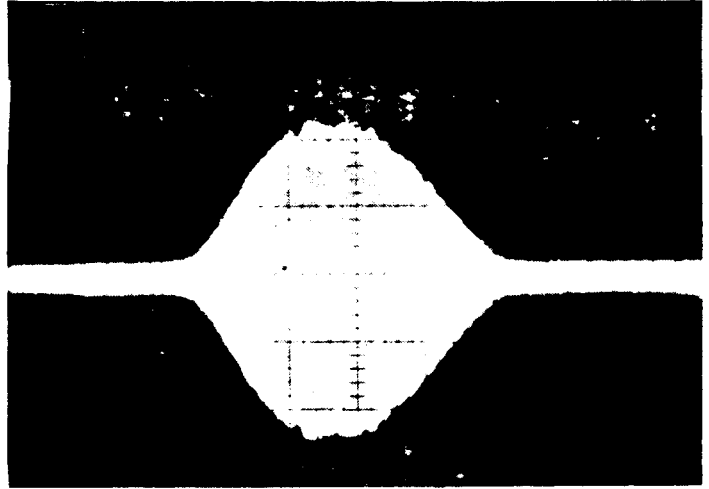

Figure 5-24 2315 CE Pack Head Alignment Waveforms (Sheet 2 of 3)

- g. Extreme misalignment. Head close to CYL 106. (Further misalignment only reduces amplitude of peak.)



To calculate % of error, use the following formula:

$$\% \text{ error} = \frac{x_1 - x_2}{x_1 + x_2} \times 100$$

x_1 and x_2 = null amplitudes. The resultant sign denotes the direction of error; a negative (-) sign indicates that the head is back too far.

Figure 5-24 2315 CE Pack Head Alignment Waveforms (Sheet 3 of 3)

- c. Adjust the fixed scale horizontally to read zero. Ensure that the calibrated edges of the fixed scale and the vernier scale are parallel and close together, without touching. Tighten the scale retaining screws.
- d. Push S1 (Figure 4-17) down and move the vernier scale horizontally through its entire range to ensure that the calibrated edges of the two scales do not touch at any point.

9. For RK05 or RK05-J drives with 2315 CE Pack, select cylinder 105 as follows:

NOTE

It is also possible to perform the following adjustments using the RK05 Exerciser or simple maintenance routines. For additional information, refer to the RK05 Exerciser Maintenance Manual.

- a. Connect backboard jumpers from A07T1, A07C2, B07T1, or any available ground pins to the following points:

A08E1 CYL ADD 6(64)

A08J1 CYL ADD 5(32)

A08C1 CYL ADD 3(8)

A08K1 CYL ADD 0(1)

105

A04V1 SEL RDY L

- b. Connect a jumper from B08H1 (STROBE) to B08N2 (SECTOR PULSE). The positioner should move to cylinder 105. Confirm this by observing the track scale indicator.

For RK05-F drive with 2315 CE Pack, select cylinder 5 as follows:

- a. Connect backboard jumpers from A07T1, A07C2, B07T1, or any available ground pins to the following points:

A08K2 ODD DRIVE
A08M2

A08L1 CYL ADD 2(4)

A08K1 CYL ADD 0(1)

5

A04V1 SEL RDY L

- b. Connect a jumper from B08H1 (STROBE) to B08N2 (SECTOR PULSE). The positioner should move to cylinder 5. Confirm this by observing the track scale indicator.

10. Monitor the scope display for one of the waveforms illustrated in Figure 5-24.

NOTE

A bright horizontal line should appear at the beginning (left) of the displayed waveform, as shown in Figures 5-24b through 5-24g. If the line does not appear, adjust the scope level control until it does. This bright line indicates proper positioning of the sectors; odd sectors (X1) on the left, even sectors (X2) on the right.

If none of the illustrated waveforms appear, the head is so badly misaligned that manual manipulation of the positioner is required. If manual manipulation is required, perform the steps that follow; if not, proceed to Step 11.

- a. Place switch S1 (Figure 4-17) in the down or OFF position, keeping a finger on the carriage while manipulating the switch to dampen any positioner transients.
 - b. Slowly move the positioner by hand until the alignment pattern occurs. Cylinders 85 and 125 have identical patterns, so be sure that the displayed pattern is for cylinder 105 (5 for the RK05-F). Do not use undue force on the positioner when manually changing track positions.
 - c. Observe the track scale and note the cylinder indication when the correct waveform (Figure 5-24d) is obtained. If the scale indicates less than 105 (5 for the RK05-F), the head is too far forward in the carriage. Conversely, if the scale indicates more than 105 (5 for the RK05-F), the head is too far back in the carriage.
 - d. Loosen the clamp and adjustment screws (Figure 5-23) and move the head in the appropriate direction until the correct waveform (Figures 5-24d) is obtained and the scale indication is slightly greater than 105 (5 for the RK05-F Disk Drive). Tightening the clamp screw firmly will cause the head to move forward slightly, bringing the scale indication to 105 (5 for the RK05-F).
 - e. Lightly tighten the clamp screw and turn on the positioner power (S1 up).
 - f. After turning off positioner power, move the positioner fully forward. Turn on positioner power (S1 up) to initiate a restore (RTZ) operation. The positioner will automatically return to cylinder 105 following the RTZ (cylinder 5 for RK05-F).
11. If one of the illustrated waveforms is present, note in which direction the head must be moved to obtain the correct indication (Figure 5-24d). If it must be moved backward, loosen the head clamp and adjustment screws and gently push the head all the way back into the carriage; if it must be moved forward, loosen only the clamp screw, and then turn the adjustment screw until the correct waveform is obtained.

The adjustment screw is a vernier that only moves the head forward; it should not be left torqued down after this adjustment.

NOTE

If the positioner is moved from cylinder 105 (or 5) during the adjustment procedure, turn off positioner power (S1 down) and manually move the positioner fully forward. Then turn on positioner power (S1 up) to initiate a restore (RTZ) operation. The positioner will automatically return to cylinder 105 following the RTZ (cylinder 5 for RK05-F).

12. Ground B08M2 to select the upper head and repeat the preceding steps.
13. Using the appropriate torque wrench (Paragraph 5.3.3.1), tighten the head clamp screw until the wrench begins to ratchet. If a torque wrench is not available, use the appropriate Allen wrench to tighten the head clamp screw snugly; do not overtighten.
14. Recheck to ensure that the clamping action did not disturb the head adjustment.

5.4.5 Index/Sector Timing Adjustment

5.4.5.1 RK05K-AC Alignment Cartridge

1. Unplug the drive ac line cord to remove power.
2. Disconnect the drive interface cable card from the electronic module and install an M930 terminator card in its place.
3. Reconnect the ac line cord to bring the drive up to operating status.
4. Install an RK05K-AC alignment cartridge on the spindle, ensuring that the mating surfaces are clean; operate the drive in the run mode for *at least 30 minutes*. This must be done to allow the alignment cartridge and the drive components to achieve thermal stabilization.
5. Using the WR PROT switch, place the drive in the write protect condition.
6. Set the oscilloscope controls as follows:

vertical
mode = ADD (invert CHAN 2)
sensitivity = 0.2 V/div
coupling = dc

sweep
A sweep time = 5 ms/div
trigger = normal

trigger
source = external*
coupling = ac
slope = -

***Important:** Use a 1:1 probe to connect the scope external trigger input to A02R2 (INDEX).

7. Connect the channel 1 probe to TP3 and the channel 2 probe to TP4 of the G180 card. (Use 10:1 probes.)
8. Ensure that the positioner track scale indicates cylinder 00 (Paragraph 5.4.4.1, Step 8).
9. For the RK05 or RK05-J drives, select cylinder 105 as follows:

NOTE

It is also possible to perform the following adjustments using the RK05 Exerciser or simple test programs.

- a. Connect backboard jumpers from A07T1, A07C2, or any available ground pins to the following points:

A08E1 CYL ADD 6(64)

A08J1 CYL ADD 5(32)

A08C1 CYL ADD 3(8)

A08K1 CYL ADD 0(1)

105

A04V1 SEL/RDY L

- b. Connect a jumper from B08H1 (STROBE) to B08N2 (BUS SECTOR PULSE). The positioner should move to cylinder 105. Confirm this by observing the track scale indicator.

For the RK05-F drive, select cylinder 5 as follows:

- a. Connect backboard jumpers from A07T1, A07C2, B07T1, or any available ground pins to the following points:

A08K2 ODD DRIVE
A08M2

A08L1 CYL ADD 2(4)

A08K1 CYL ADD 0(1)

5

A04V1 SEL RDY L

- b. Connect a jumper from B08H1 (STROBE) to B08N2 (SECTOR PULSE). The positioner should move to cylinder 5. Confirm this by observing the track scale indicator.
10. Monitor the scope for a single pulse followed by data beginning 10 μ s following the pulse. This timing pulse may be either positive or negative going. Cylinders 85 and 125 also contain this pulse, and can be used if 105 is unusable (RK05/RK05-J only).

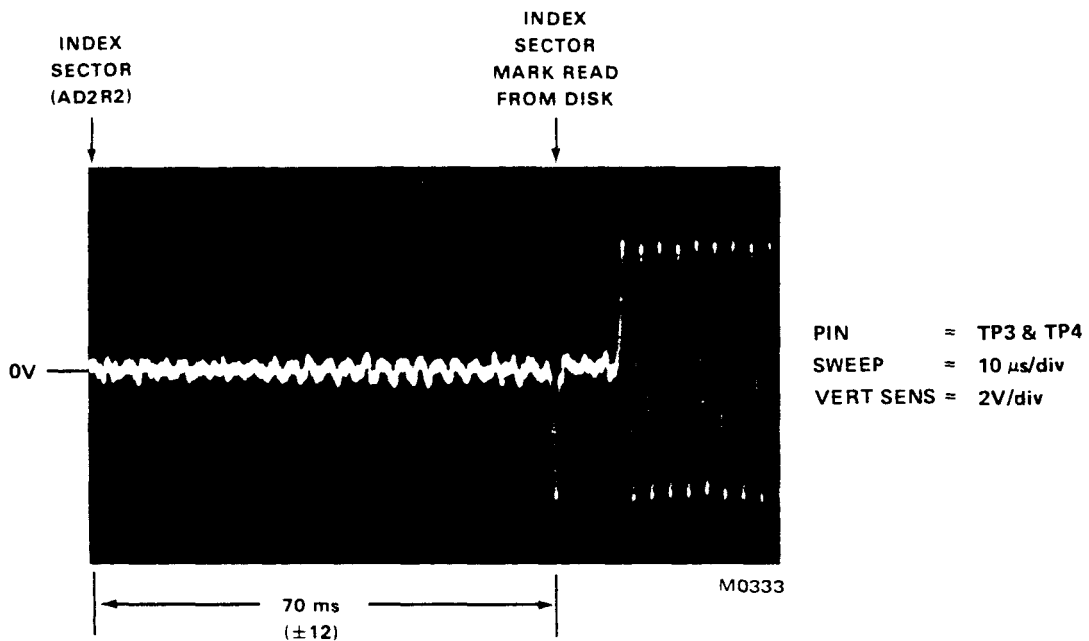

Figure 5-25 Index/Sector Waveform

12. Ground B08M2 to select the upper head and check for the same pulse tolerances as in Step 11, above. If necessary, adjust R6 on the M7680/M7700 (card position 2) until the average time for the two pulses is 70 μs and the 70 ± 12 μs individual pulse requirement is maintained. If these requirements cannot be achieved, perform either of the following corrective actions:
 - a. If the time difference of the two timing pulses exceeds 24 μs, replace one of the heads to reduce the difference. Once the difference is within tolerable limits, readjust R6 to achieve an average 70 μs between the peaks.
 - b. If the average of the peaks cannot be adjusted to 70 μs, relocate the sector transducer to the right (if the average is too high) or to the left (if the average is too low). Readjust R6 to achieve an average 70 μs between peaks.

5.4.5.2 2315 CE Pack

NOTE

Do NOT use this procedure with the DEC RK05K-AC alignment cartridge; use the procedure from Paragraph 5.4.5.1.

1. Unplug the drive ac line cord to remove power.
2. Disconnect the drive interface cable card from the electronic module and install an M930 terminator card in its place.
3. Reconnect the ac line cord to bring the drive up to operating status.
4. Install a 2315 CE test cartridge on the spindle, ensuring that the mating surfaces are clean, and operate the drive in the run mode for *at least 30 minutes*. This must be done to allow the CE cartridge and the drive components to achieve thermal stabilization.
5. Using the WR PROT switch, place the drive in the write protect condition.
6. Set the oscilloscope controls as follows:

vertical
mode = ADD (invert CHAN 2)
sensitivity = 0.2 V/div
coupling = dc

sweep
A sweep time = 10 ms/div
trigger = normal

trigger
source = external*
coupling = ac
slope = -

***Important:** Use a 1:1 probe to connect the scope external trigger input to A02R2 (INDEX).

7. Connect the channel 1 probe to TP3 and the channel 2 probe to TP4 of the G180 card. (Use 10:1 probes.)
8. Ensure that the positioner track scale indicates cylinder 00 (Paragraph 5.4.4.2, Step 8).
9. For RK05 or RK05-J drives with 2315 CE Pack, select cylinder 105 as follows:

NOTE

It is also possible to perform the following adjustments using the RK05 Exerciser or simple test programs.

- a. Connect backboard jumpers from A07T1, A07C2, or any available ground pins to the following points:

A08E1 CYL ADD 6(64)

A08J1 CYL ADD 5(32)

A08C1 CYL ADD 3(8)

A08K1 CYL ADD 0(1)

105

A04V1 SEL/RDY L

- b. Connect a jumper from B08H1 (STROBE) to B08N2 (BUS SECTOR PULSE). The positioner should move to cylinder 105. Confirm this by observing the track scale indicator.

For RK05-F drive with 2315 CE Pack, select cylinder 193 with jumpers as follows:

- a. Connect backboard jumpers from A07T1, A07C2, or any available ground pins to the following points:

A08K2 } EVEN DRIVE
A08M2 }

A08A1 CYL ADD 7(128)

A08E1 CYL ADD 6(64)

A08K1 CYL ADD 0(1)

ODD DRIVE (193)

A04V1 SEL/RDY L

- b. Connect a jumper from B08H1 (STROBE) to B08N2 (SECTOR PULSE). The positioner should move to cylinder 193. Confirm this by observing the track scale indicator.
10. Monitor the scope for a single pulse followed by a 1-ms burst of data. This pulse may be of *either* polarity.
 11. Expand the sweep time to 10 μ s/div and check that the single pulse occurs 70μ s \pm 12 μ s from the start of the sweep (Figure 5-24). This pulse may be of *either* polarity.
 12. Ground B08M2 to select the upper head and check for the same pulse tolerances as Step 11, above. If necessary, adjust R6 on the M7700 card (card position 2) until the average time for the two pulses is 70 μ s and the $70 \pm 12 \mu$ s individual pulse requirement is maintained. If these requirements cannot be achieved, perform either of the following corrective actions:
 - a. If the time difference of the two timing pulses exceeds 24 μ s, replace one of the heads to reduce the difference. Once the difference is within tolerable limits, readjust R6 to achieve an average 70 μ s between the peaks.

- b. If the average of the peaks cannot be adjusted to $70 \mu\text{s}$, relocate the sector transducer to the right (if the average is too high) or to the left (if the average is too low). Readjust R6 to achieve an average $70 \mu\text{s}$ between peaks.

5.4.6 Cartridge Receiver Alignment

There are two styles of cartridge receiver in the RK05 and RK05-J. The earlier style is an all-wire construction mounted on adjustable pivot posts (Figures 5-26 and 5-27). The later style (Figure 5-28) has a sheet metal "roof" and two rotating plastic clamps on the forward crosswire, and is mounted in a sheet metal bracket that is completely nonadjustable. The RK05-F with its nonremovable cartridge has no cartridge receiver as such. Instead, it has a cartridge guide, an access door wedge, and two hold-down springs (Figure 5-29). The description in this paragraph applies to the earlier RK05/RK05-J cartridge receiver.

Prior to shipment of the RK05 Disk Drive, the cartridge receiver is precisely aligned at the factory. Since it is not necessary to disturb the receiver alignment when performing any of the field maintenance procedures, cartridge receiver alignment is not normally required in the field. However, if the duckbill, airduct, or cartridge support posts are replaced, the cartridge receiver alignment must be checked. In addition, the Cartridge-On switch should also be checked for proper operation.

NOTE

The duckbill on later model drives differs slightly from that on earlier models. If an earlier version duckbill should be replaced by a later version, the airduct and cartridge support posts must also be replaced. Refer to the RK05 Illustrated Parts Breakdown (DEC-RK05-IPB-1) to identify which duckbill version is being replaced.

1. Slide the drive out of the rack and remove the top and bottom covers.
2. Insert a cartridge into the receiver and close the drive front door.
3. Check for a 0.020 to 0.040-inch clearance (A in Figure 5-26) between the plastic cartridge case and the receiver rails. Perform this measurement toward the rear of the receiver at a point where the plastic cartridge case passes over the intersecting receiver rails.
4. If the (A) clearance is incorrect, loosen the pivot post lock nuts and adjust the height of both posts to obtain the proper clearance. Hold the pivot post at (X) with an adjustable wrench while loosening and tightening the lock nuts (Y).
5. Lightly tighten the pivot post lock nuts and check the following (Figure 5-27).
 - a. Remove the cartridge and ensure that the clearances (B) between the upper receiver rails and the cartridge channel are equal, and that the receiver rails are as parallel as possible to the channel.
 - b. Push the receiver all the way to one side and ensure that there is a slight clearance (C) of 0.010 to 0.040-inches between the pivot post and the receiver hinge rail. When making this check, do not push the receiver so hard that the pivot posts twist.
 - c. Push the receiver to the left and right, ensuring that the front receiver rail does not touch either side of the chassis.

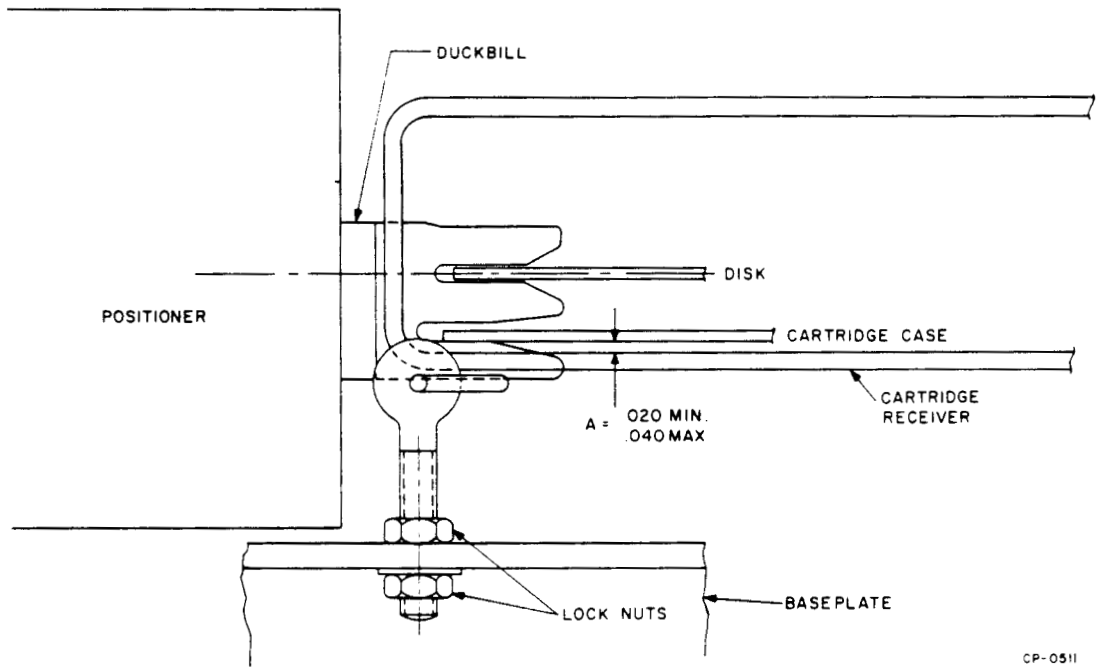

Figure 5-26 Cartridge-to-Receiver Clearance

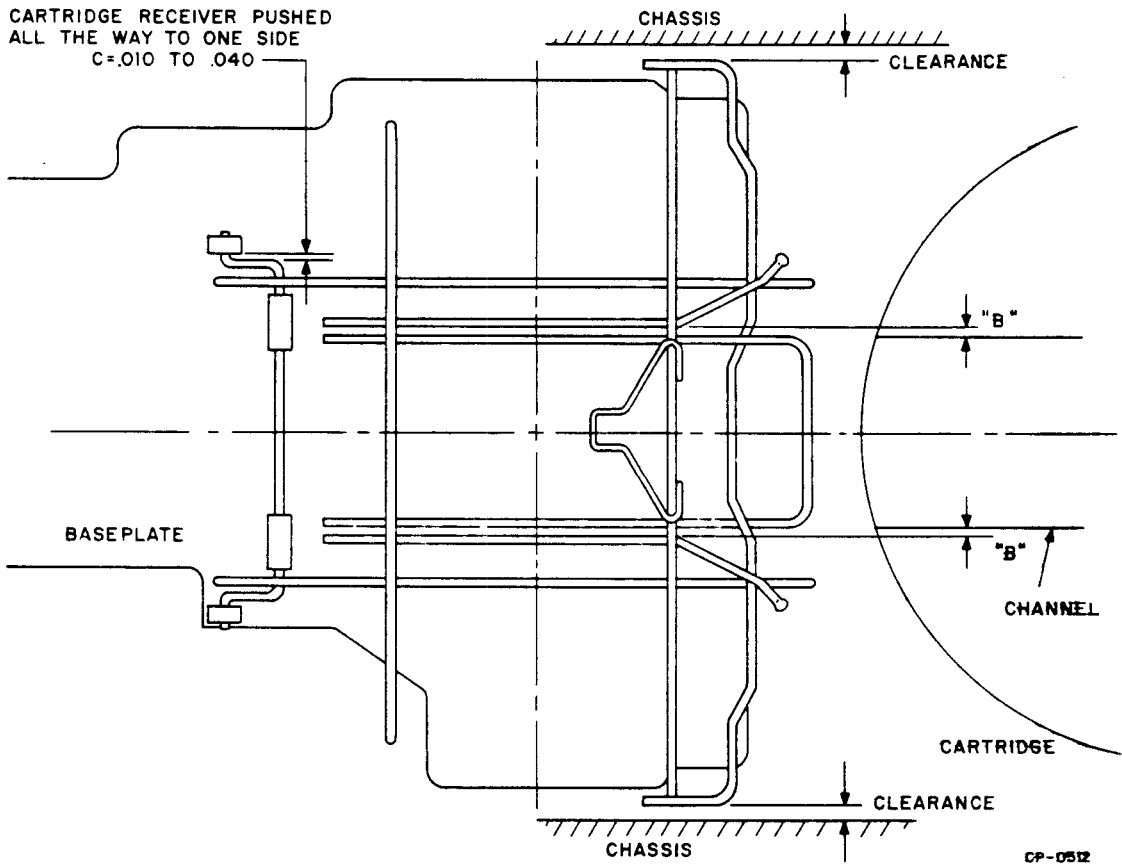
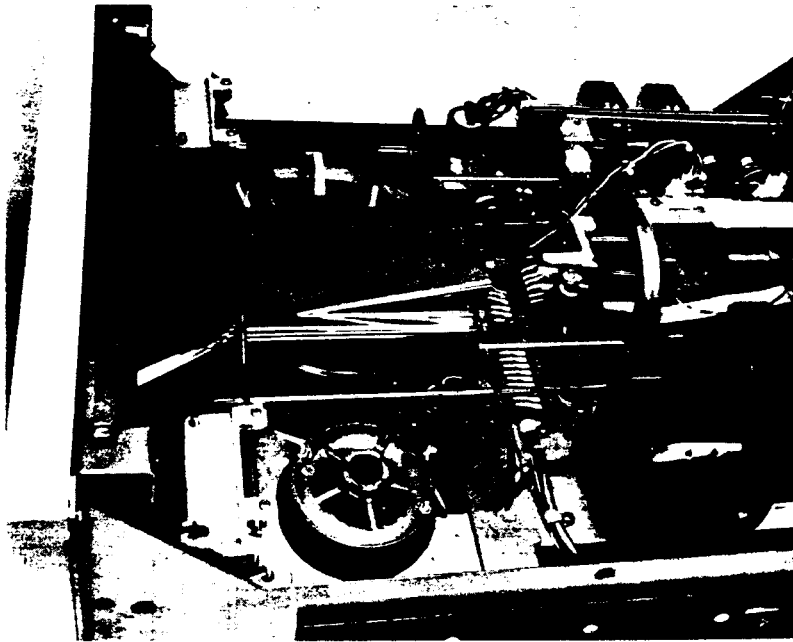
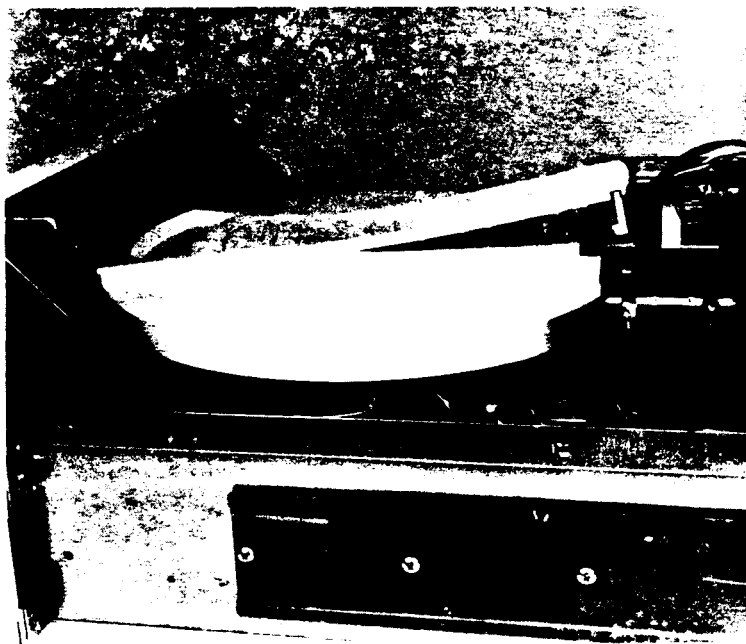

Figure 5-27 Cartridge Receiver Clearances



7869-16

Figure 5-28 Cartridge Receiver, Newer Models (RK05/RK05-J)



7869-4

Figure 5-29 Cartridge Receiver, RK05-F

6. Tighten the pivot post lock nuts and recheck all clearances. There must be clearances at points (A), (B), and (C); however, it is particularly important that clearances (A) and (C) do not exceed the limits indicated in Figures 5-26 and 5-27.
7. Check for the following points of contact between the cartridge and the cartridge receiver, which indicate that the cartridge is properly seated:
 - a. Two thin rails (these should either touch evenly or be parallel along the full length of the cartridge.)
 - b. Two cartridge posts
 - c. Access door opener bail
 - d. Spring at top center of cartridge
 - e. Duckbill (lower slot)
 - f. Airduct bridge
 - g. Airduct foam seal.
8. Check for the following points of clearance between the cartridge and the cartridge receiver, which indicate that the cartridge is properly seated:
 - a. Two fat rails on top of the cartridge
 - b. Four crosspoints on the underside of the cartridge
 - c. The pivot posts and receiver hinge bail.

The position of the pivot posts determines how the top rails ride on the cartridge and also determines the bottom clearances of the four crosspoints and the underside of the carriage.

One way to check alignment is to insert a cartridge pack at a slightly cocked angle. The receiver should guide the pack onto the posts as the door is closing. If a pack will not seat on the left post, make sure that the top rails of the receiver are not pushing the pack away.

NOTE

Remember that the receiver does not hold, but merely guides the cartridge. The pack is actually positioned by the two cartridge posts and the lower tip of the duckbill. The pack should not rest on or be tightly squeezed by the cartridge receiver, but should be able to slide easily.

5.5 SPARE PARTS

Refer to the RK05 Illustrated Parts Breakdown (DEC-RK05-IPB-1) and the H743 Power Supply Illustrated Parts Breakdown (DEC-H743-IPB-1) for parts identification.

5.6 TROUBLESHOOTING

The information in this paragraph will assist the service technician in isolating a failing drive component. This information is intended only as a guide during trouble analysis, and does not cover all possible malfunctions of any designated area. To eliminate correctly functioning areas of the drive and arrive at an area of failure, perform the checks described in Paragraphs 5.6.1 through 5.6.4. A basic knowledge of electronics, primary understanding of DEC logic, and logical deductive reasoning should then be employed to locate faulty components within the area of failure. Figure 5-30 consists of a quick-reference flowchart illustrating the checks described in detail in the following paragraphs.

Once the malfunction is diagnosed, corrective maintenance should be performed largely through module swapping. The term module includes those modules listed in the UML (Dwg. No. RK05-0-2), in addition to the linear positioner, the +5 Vdc regulator, the ± 15 Vdc regulators, and the H604 Servo Power Amplifier. Failures not attributable to these modules must be repaired at the faulty component level. If module replacement cannot be accomplished within a practical time period, repair of the defective modules should be undertaken, with the exception of a defective linear positioner. In all cases, defective linear positioners should be returned to Digital Equipment Corporation, Maynard, Mass.

NOTE

The G180 module should not be used on an extender module. Faulty G180s should be replaced in the field, rather than repaired at the faulty component level, if the nature of the fault is such that an extender module would normally be required.

5.6.1 Power Supply

1. Open the rear door of the rack and unplug the drive ac line cord.
2. Extend the drive fully on the slides and remove the top cover.
3. Disconnect P1 (Figure 4-17) from the power supply chassis.
4. Apply power to the drive and check J1 for the following voltages (measured from ground to the center value of the peak-to-peak ripple):

pin 1 = +15 \pm 0.75 Vdc	} 250 mV p-p max ripple of either regulator
pin 2 = -15 \pm 0.75 Vdc	
pin 3 = +5 \pm 0.15 Vdc	} 200 mV p-p max ripple of either regulator

5. Remove power from the drive and check for shorts between buses.

AT1, BT1 = GND

AA2, BA2 = +5 Vdc } Max allowable ripple voltage seen at these pins on the logic assembly is 200 mV p-p.

AD2, BD2 = +15 Vdc } Max allowable ripple voltage seen at these pins on the logic assembly is 250 mV p-p.

6. Reconnect P1 and apply power to the drive.
7. Measure the +5, +15, and -15 Vdc at the buses as indicated in Step 5, above. The tolerances should be the same as those in Step 4, above.
8. Check for approximately 30 Vac at A04E1.
9. Remove power from the drive.

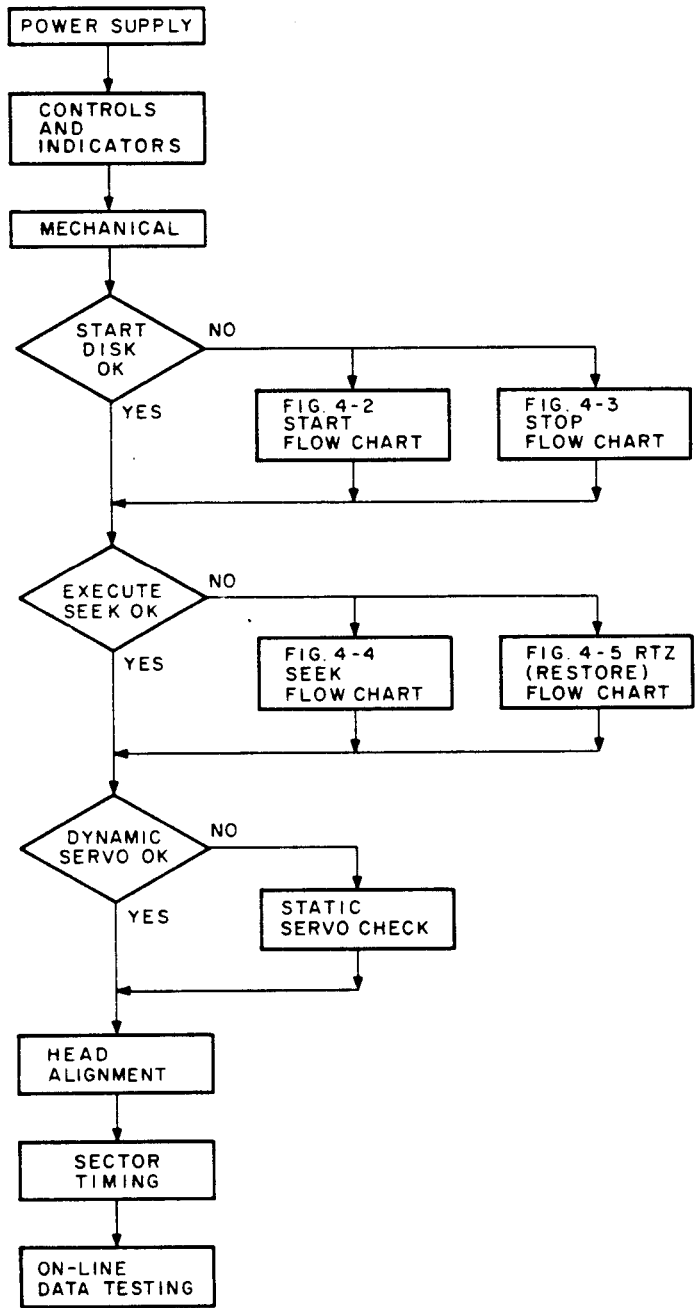

CP-0533

Figure 5-30 Troubleshooting Flowchart

5.6.2 Controls and Indicators

1. Check that all modules are present and in their correct locations (Dwg. No. RK05-0-2).
2. Apply power to the drive and check that:
 - a. the PWR and LOAD indicators are lit and that the WT and RD indicators are OFF. (WT and RD can be checked while formatting a cartridge during the diagnostic exercise.)
 - b. the door unlocking solenoid is energized.
 - c. the blower is operating.
3. Press the WT PROT switch and check that the WT PROT indicator lights. (The drive should power-up with WT PROT off.)

5.6.3 Mechanical Checks

1. Open the rear door of the rack and unplug the drive ac line cord.
2. Extend the drive fully on the slides, and remove the bottom covers.
3. Tape the door-locking bar (located behind the front bezel) in the down position (Figure 5-31). This permits the drive front door to be opened and shut without power being applied. (This does not apply to the RK05-F.)
4. Install a test cartridge in the drive.

CAUTION

Do not attempt to cycle up the drive with the locking bar disabled.

5. Check the following to ensure that the cartridge is seated properly:
 - a. Ensure that there is a clearance between the lip on the metal disk hub and the sector transducer slot (Figure 5-32).
 - b. The airduct foam seal fits snugly to the bottom of the cartridge case.
 - c. The cartridge case rests securely on the front cartridge support posts. (No gaps between the cartridge case and the support posts shoulders.)
6. Rotate the spindle pulley by hand and check that:
 - a. the disk surface does not touch the duckbill.
 - b. there is no scraping or rubbing sound within the drive.
 - c. the drive belt is not stretched or worn.

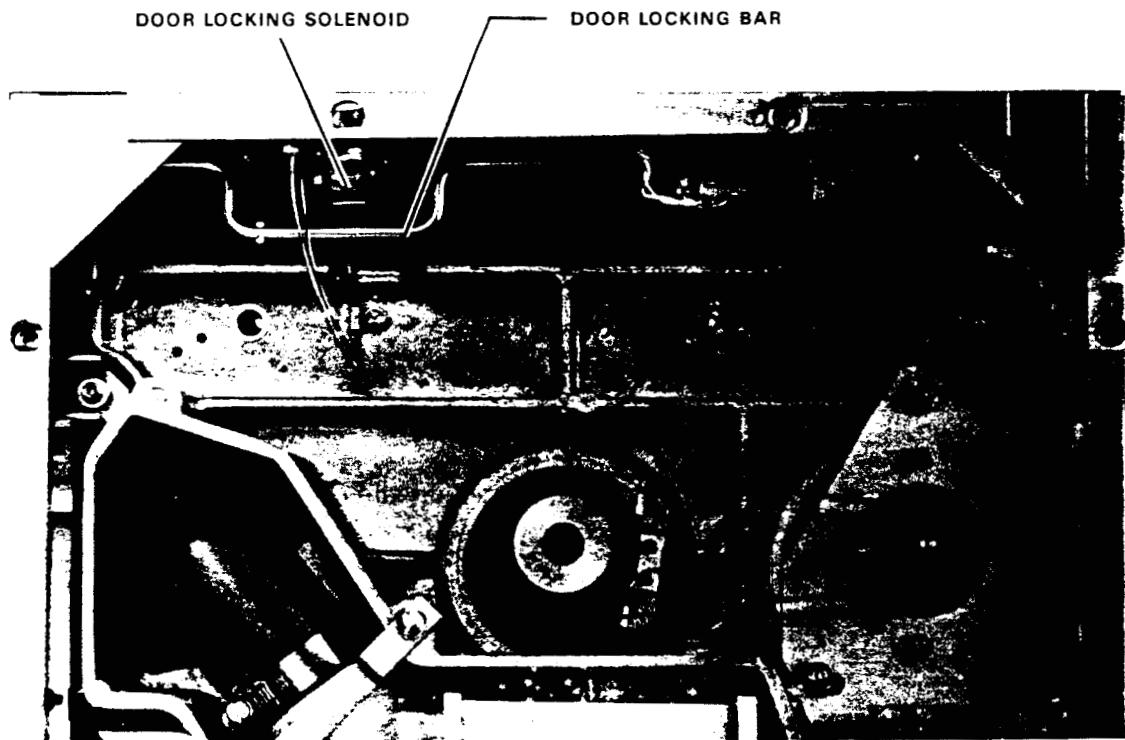

7553-5

Figure 5-31 Door Locking Bar Location

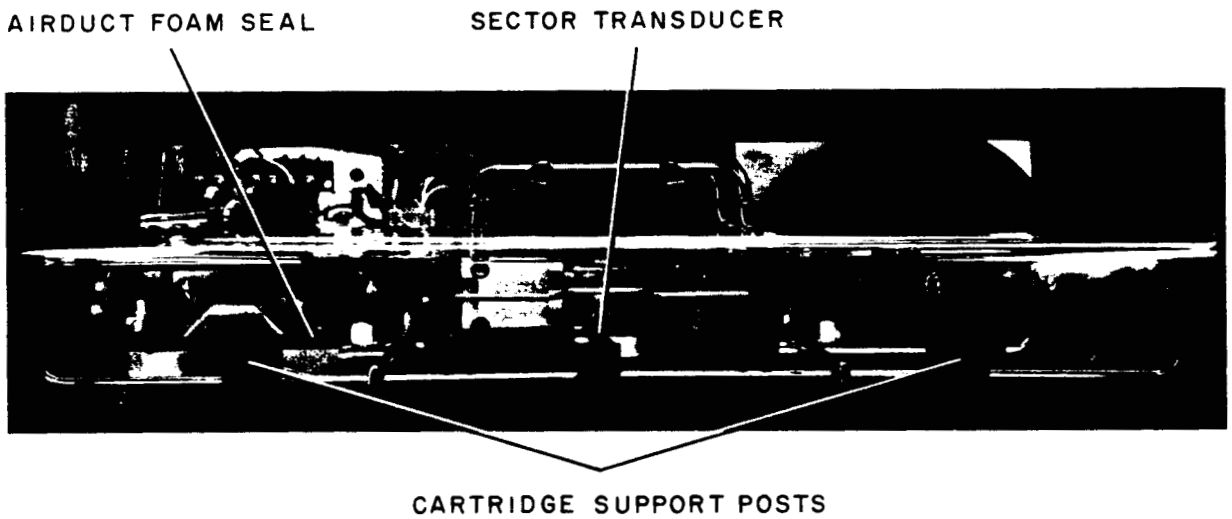

Figure 5-32 Cartridge Seating Elements

7. Remove the tape from the door-locking bar and apply power to the drive (if RK05 or RK05-J Disk Drive).

Place the RUN/LOAD switch in the RUN position and check that:

- a. the PWR indicator is lit.
 - b. the disk is rotating and there is still no rubbing sound from within the drive.
 - c. after approximately 8 seconds, the heads load.
 - d. the RDY and ON CYL indicators are lit.
 - e. the door is now locked.
8. Place the RUN/LOAD switch in the LOAD position and check that the door unlocks when the LOAD light comes on.
 9. Remove power from the drive.

5.6.4 Electronic Checks

1. If possible, perform the Dynamic Off-Line Servo System Timing Checks (Paragraph 5.4.2.1). If there is any question about the drive operating well enough to accomplish the dynamic servo timing checks, perform the Static Tests and Adjustments (Paragraph 5.4.2.2).

NOTE

When attempting the preceding checks, if the drive does not start or stop correctly, refer to the Start Flowchart (Figure 4-2) or the Stop Flowchart (Figure 4-3) for areas of possible malfunction. If the drive starts properly but does not execute a Seek or Restore command correctly, refer to the Seek Flowchart (Figure 4-4) or the Restore Flowchart (Figure 4-5).

2. Verify that the heads are correctly aligned (Paragraph 5.4.4).
3. Check the Index/Sector Timing (Paragraph 5.4.5).
4. Remove all jumpers and configure the drive for normal operation.
5. Ensure that spindle brushes are mating properly and that the ground strap between the chassis and the baseplate is secure; otherwise, random data errors may result.
6. Inspect the logic assembly for bent or shorting pins.
7. Check the power supply voltages.
8. Run the appropriate diagnostic tests to exercise the remaining portions of the drive.

Your comments and suggestions will help us in our continuous effort to improve the quality and usefulness of our publications.

What is your general reaction to this manual? In your judgment is it complete, accurate, well organized, well written, etc.? Is it easy to use? _____

What features are most useful? _____

What faults do you find with the manual? _____

Does this manual satisfy the need you think it was intended to satisfy? _____

Does it satisfy *your* needs? _____ Why? _____

Would you please indicate any factual errors you have found. _____

Please describe your position. _____

Name _____ Organization _____

Street _____ Department _____

City _____ State _____ Zip or Country _____

CUT OUT ON DOTTED LINE

