

digital

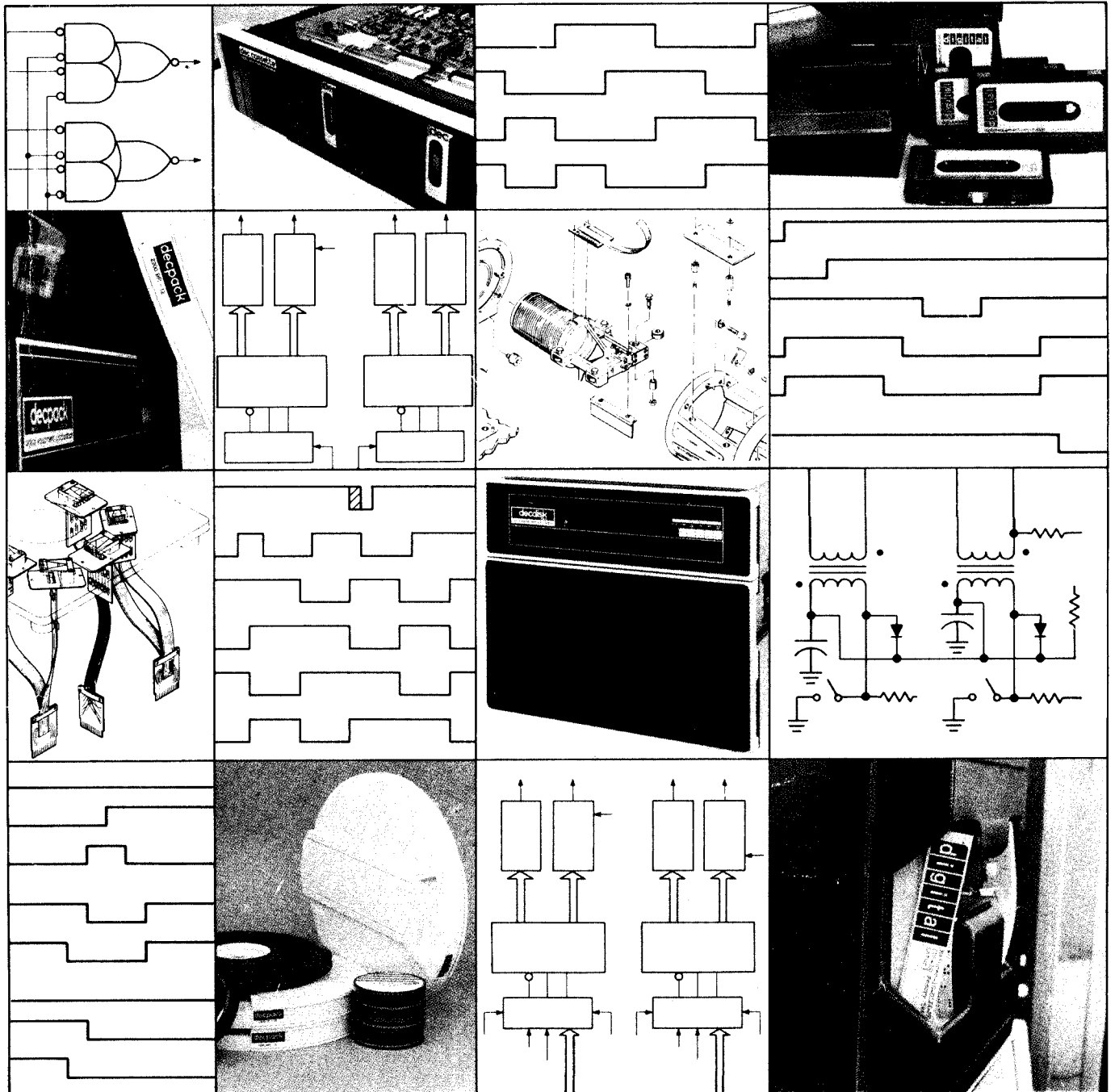

**TU56DECtape
transport
maintenance manual**

DEC-00-HRTC-D

1st Edition, June 1970
2nd Printing (Rev) March 1971
3rd Printing, October 1971
4th Printing, March 1972
5th Printing, June 1972
2nd Edition, July 1972
7th Printing, January 1973
8th Printing, September 1973

Copyright © 1970, 1971, 1972, 1973 by Digital Equipment Corporation

The material in this manual is for informational purposes and is subject to change without notice.

The following are trademarks of Digital Equipment Corporation, Maynard, Massachusetts:

FLIP CHIP	DECtape
UNIBUS	DECsystem-10
PDP	DECmagtape

CONTENTS

	Page
CHAPTER 1 GENERAL INFORMATION	
1.1	Introduction 1-1
1.2	Specifications 1-1
1.3	Options 1-3
1.4	Major Assemblies and Systems 1-4
1.4.1	Controls and Indicators 1-4
1.4.2	Tape Motion System 1-5
1.4.3	Power Supply 1-7
CHAPTER 2 INSTALLATION	
2.1	Unpacking and Inspection 2-1
2.2	Mechanical Installation 2-3
2.2.1	Mounting Support Plate Bracket and Spacer Block Installation 2-3
2.2.2	Spacer Support Bracket Installation 2-3
2.2.3	Transport Installation 2-4
2.3	Electrical Installation 2-6
2.4	Operation 2-8
2.4.1	Tape Loading and Unloading 2-8
2.4.2	On-Line Operating Procedures 2-8
CHAPTER 3 THEORY OF OPERATION	
3.1	Interface 3-1
3.1.1	Input Interface Lines – Command Cable – A06/A07 3-2
3.1.1.1	Select 0–7 3-2
3.1.1.2	CON STOP 3-2
3.1.1.3	CON GO 3-2
3.1.1.4	CON REV REM 3-2
3.1.1.5	CON FWD REM 3-2
3.1.1.6	CON ALL HALT 3-2
3.1.1.7	CON PWR UP DLY 3-2
3.1.2	Output Interface Lines – Command Cable – A06/A07 3-2
3.1.2.1	Select Echo 3-2
3.1.2.2	Write Echo 3-3
3.1.3	Bi-Directional Interface Lines – Information Cable – AB10/AB11 3-3
3.1.3.1	Timing Track (TT) 3-3
3.1.3.2	Mark Track (MT) 3-3
3.1.3.3	Data Tracks (D0–D2) 3-3
3.2	Functional Information 3-3
3.2.1	Read/Write Head 3-3
3.2.2	DECTape Format 3-3
3.3	Local (off-line) Operation 3-5
3.3.1	Forward Tape Motion 3-5

CONTENTS (Cont)

		Page
3.3.2	Hold Tape Motion	3-5
3.3.3	Reverse Tape Motion	3-5
3.4	Remote (on-line) Operation	3-6
3.4.1	Tape Transport Addressing	3-7
3.4.2	Error Checks	3-7
3.4.2.1	Select Echo	3-7
3.4.2.2	Write Echo	3-8
3.4.3	Tape Motion Control	3-8
3.4.4	Write Operation	3-9
3.4.5	Read Operation	3-11
3.5	Module Description	3-11
3.5.1	G847 Dual Motor Voltage Control	3-11
3.5.2	G848 Motor Control Module	3-11
3.5.3	G859 Clock Regulator Module	3-12
3.5.4	G888 Manchester Reader/Writer Module	3-12
CHAPTER 4 MAINTENANCE		
4.1	Recommended Tools and Test Equipment	4-1
4.2	Preventive Maintenance	4-1
4.2.1	Weekly PM Procedure	4-1
4.2.2	Monthly PM Procedure	4-2
4.2.3	Tape Care and Cleaning	4-2
4.3	Corrective Maintenance	4-3
4.3.1	Control Panel Lamp Replacement	4-3
4.3.2	Reel Motor	4-3
4.3.2.1	Motor Removal	4-3
4.3.2.2	Motor Replacement	4-4
4.3.2.3	Reel Hub Clearance Adjustment	4-5
4.3.2.4	Reel Motor Electronic Brake Adjustment	4-5
4.3.2.5	40-Hz Oscillator Adjustment	4-5
4.3.3	Read/Write Head	4-5
4.3.3.1	Head Removal	4-5
4.3.3.2	Head Replacement	4-7
4.3.3.3	Head Output Check	4-7
4.3.3.4	Head Skew Check and Adjustment	4-8
4.3.3.5	Write Enable Circuit Check	4-11
4.4	Troubleshooting	4-11
4.4.1	Initial Checks	4-11
4.4.2	Signal Source and Termination Tests	4-14
4.5	Recommended Spare Parts	4-18
APPENDIX A REFERENCE DRAWINGS		

ILLUSTRATIONS

Figure No.	Title	Page
1-1	Controls and Indicators	1-4
1-2	Tape Motion System	1-6
1-3	Power Supply Location	1-7
2-1	Outer Packaging	2-1
2-2	Inner Packaging	2-2
2-3	H950 Cabinet Support Plate	2-3
2-4	Tubular Cabinet Spacer Support Bracket	2-4
2-5	Faceplate Removal	2-5
2-6	Hub and Reel	2-7
3-1	TC08 to TU56 Logic Connection	3-1
3-2	Functional Block Diagram	3-3
3-3	Read/Write Head Arrangement	3-4
3-4	Off-Line Manual Operation Flow Chart	3-6
3-5	Read/Write Technique	3-10
4-1	Reel Motor Removal	4-4
4-2	Reel Hub Clearance	4-6
4-3	Head Connector Location	4-8
4-4	Skew Tester to Head Cable Connection	4-9
4-5	Head Skew Waveform	4-10
4-6	G848 Motor Control Module Waveforms	4-13
4-7	M908 Module Layout	4-15

TABLES

Table No.	Title	Page
1-1	Performance Specifications	1-1
1-2	Logic Modules	1-3
1-3	Controls and Indicators	1-4
2-1	TU56 and TU56H Interface Cabling	2-6
2-2	Interface Module Substitution	2-7
4-1	Recommended Maintenance Equipment	4-1
4-2	Reel Motor Malfunctions	4-11
4-3	Control Panel Malfunctions	4-12
4-4	Local Malfunctions	4-12
4-5	Left Transport Source Test Points	4-15
4-6	Right Transport Source Test Points	4-16
4-7	Right and Left Transport Termination Test Points	4-16
4-8	Recommended Spare Parts	4-18

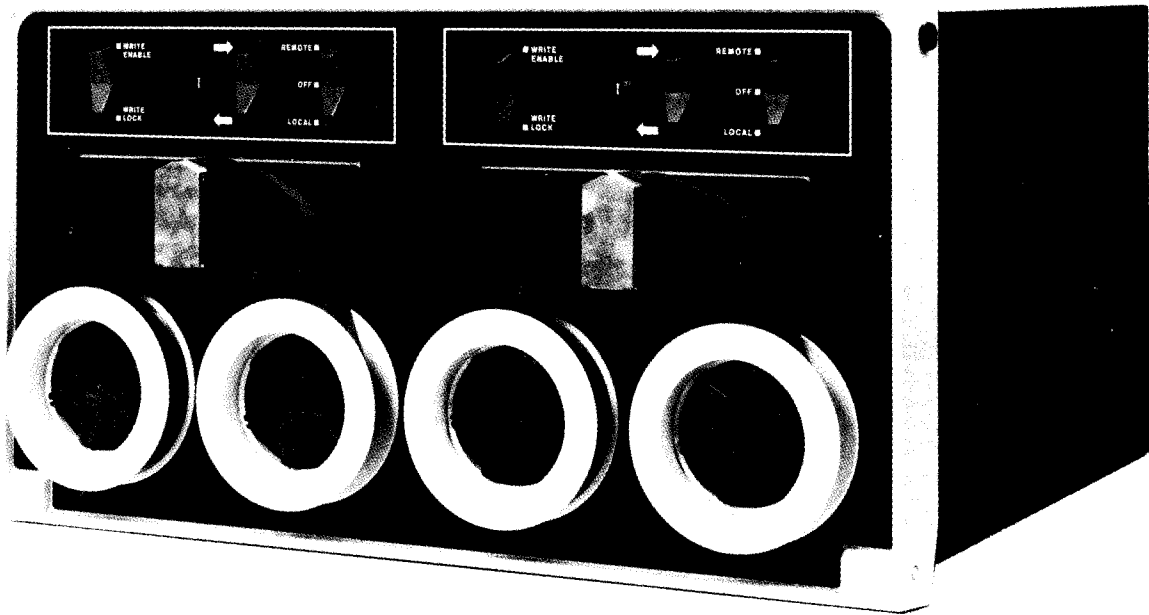

TU56 DECTape Transport

CHAPTER 1

GENERAL INFORMATION

1.1 INTRODUCTION

The TU56 (Dual) or TU56H (Single) DECTape Transport is a solid state, bi-directional, low cost, magnetic tape data storage device. The Manchester Phase encoding method used in this transport ensures reliable data transfer and reduces tape skew problems. Each tape track is redundantly paired with a second, nonadjacent track, thus permitting dependable use of a lower cost (instrumentation) tape without requiring a closely controlled environment.

The TU56 tape speed is 93 inches per second, with a data transfer rate of 33,300 3-bit characters per second. The simple tape transport mechanism has no capstans or pinch rollers. Tape motion is controlled by two ac induction reel motors. The internal H725 Power Supply furnishes dc operating power for the reel motors only. DC logic power is externally supplied by the tape controller through connectors located on the back of the power supply. To maintain proper tape tension during forward tape motion, full torque is applied to the forward reel motor while reduced torque is applied to the reverse reel motor. Similarly, during reverse tape motion, full torque is applied to the reverse reel motor while reduced torque is applied to the forward reel motor. Electronic braking ensures a positive stop from either direction, without appreciable tape backlash.

With the use of optional interface modules, the solid state switching circuits in the TU56 can be made compatible with the relay switching circuits in the TU55 and 555 DECTape Transports. This versatile tape transport can therefore be used in a variety of installations, including those not employing Digital Equipment Corporation (DEC) computers.

1.2 SPECIFICATIONS

Table 1-1 lists the performance specifications of the TU56 DECTape Transport.

Table 1-1
Performance Specifications

Characteristic	Parameter
<i>Controller Type and Output Levels</i>	
Integrated Circuits	F = ground T = +5 Vdc
Relay	F = open T = closed
Solid State	F = ground T = -3 Vdc

(continued on next page)

Table 1-1 (Cont)
Performance Specifications

Characteristic	Parameter
<i>Electrical Requirements</i>	
Input Voltage	115/220 Vac, 50/60 Hz @ 3A $+5 \pm 0.5$ Vdc @ 0.8A $+10 \pm 1.0$ Vdc @ 0.8A -15 ± 1.5 Vdc @ 0.8A } either +5 or +10 Vdc, but not both*
Power Dissipation	TU56 = 325W (1073 Btu/hr) max TU56H = 162.5W (536.5 Btu/hr) max
<i>Environment</i>	
Ambient Temperature	60 to 95°F (15 to 35°C)
Relative Humidity	20 to 80% (no condensation)
<i>Storage Medium</i>	
Type	Mylar sandwich, magnetic recording tape
Width	3/4 in.
Thickness	1.25 mil
Data Capacity	2.7 x 10 ⁶ bits (unformatted)
Format	Manchester Phase Encoding
<i>Tape Reel</i>	
Outer Diameter	3-7/8 in.
Diameter Ratio	Approximately 1:1.4 (min. to max.)
Capacity	260 ft
<i>Tape Motion Times</i> (90% full speed)	
Start	150 ± 15 ms
Stop	100 ± 10 ms
Turnaround	200 ± 50 ms
Backlash	<1.0 in. tape motion after braking
<i>Tape Transport</i>	
Speed	93 ± 12 in. per sec (ips)
Recording Density	350 ± 55 bits per in. (bpi)
Transfer Rate	33,300 3-bit characters per sec
<i>Dimensions and Weight</i>	
Width	19 in. (0.48m)
Depth	17-3/4 in. (0.43m)
Height	10-1/2 in. (0.27m)
Weight	80 lb (37 kg)

* Either +5 or +10 Vdc external voltage may be used; however, the internal logic requires +5 Vdc for normal operation. If +10 Vdc is used, ensure that it is connected to the correct rear terminal; otherwise circuit damage will result.

1.3 OPTIONS

The TU56 DECTape Transport is available in the following standard models:

- TU56 (Dual) Transport
- TU56H (Single) Transport

In addition, two customer options, designated TU56M (Dual) and TU56HM (Single), permit the standard transport models to be used alone or connected with other nonstandard peripherals. If either option is used, five G888 Read/Write Amplifier modules must be inserted into slots A13, A14, B13, B14, and B15 of the logic mounting block. Interface cabling as indicated in Table 2-1 must be used. If more than one transport is connected to a single controller, only the first transport of the "daisy chain" need contain the G888 modules. If the transport is connected to a controller that has relay driver outputs, the M941 Jumper modules in slots A04 and A05 must be replaced with W513 Level Amplifier modules. Table 1-2 lists the logic module complement of each transport model.

Table 1-2
Logic Modules

Quantity		Type	Module Name
TU56 Dual Transport	TU56H Single Transport		
1	1	(1) G742	Positive Logic Jumper Card
1	1	G859	Clock Regulator
2	1	(2) M941	Jumper Card
1	1	(1) M531	Bus Converter
2	1	M040	Solenoid Driver
2	1	G851	Relay
2	1	M117	6-4 Input NAND Gate
3	2	M113	10-2 Input NAND Gate
1	1	M302	Dual Delay MV
4	2	G848	Motor Control
2	2	M908	Connector
2	2	W032	Cable Connector
5	5	(3) G888 option	Manchester Reader/Writer
2	1	M922	Cable Connector
1	1	(3) M923 option	Cable Connector
2	1	G847	Dual Motor Voltage Control

(1) M531 used with negative logic controller. G742 used with positive logic controller.

(2) Replace with a W513 when transport is connected to a relay driver controller.

(3) Required only when transport is connected with nonstandard peripherals, or is to be used alone.

1.4 MAJOR ASSEMBLIES AND SYSTEMS

1.4.1 Controls and Indicators

The controls and indicators (Figure 1-1) required for normal operation are located on the front of the transport cabinet. Table 1-3 describes the function of each control or indicator.

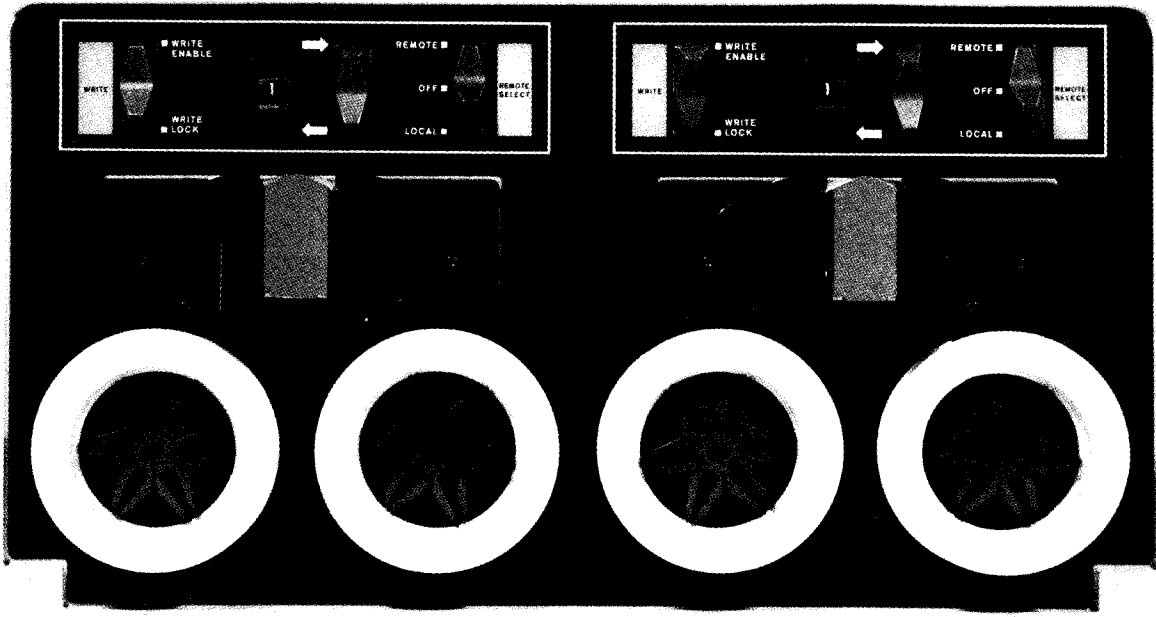

Figure 1-1 Controls and Indicators

Table 1-3
Controls and Indicators

Controls and Indicators	Logic Symbol	Description
REMOTE/OFF/LOCAL (rocker switch)	SW2	Placing this switch in one of the following positions accomplishes: <ul style="list-style-type: none"> a. REMOTE – disables the Fwd/Hold/Rev switch and places the transport under computer control (on-line). b. LOCAL – enables the Fwd/Hold/Rev switch and removes the transport from computer control (off-line). c. OFF – removes power from the reel motors and removes the transport from computer control.

(continued on next page)

Table 1-3 (Cont)
Controls and Indicators

Controls and Indicators	Logic Symbol	Description
<p align="center">→ ← Fwd/Hold/Rev (rocker switch: spring-loaded to Hold)</p>	SW3	<p>Placing this switch in the Fwd position (provided REMOTE/OFF/LOCAL is in LOCAL) moves the tape from left to right across the read/write head.</p> <p>When this switch is in the spring-loaded Hold position (provided REMOTE/OFF/LOCAL is in LOCAL), the tape remains stationary.</p> <p>Placing this switch in the Rev position (provided REMOTE/OFF/LOCAL is in LOCAL) moves the tape from right to left across the read/write head.</p>
Address Select (0 to 7 thumbwheel switch)	SW1	Configures the transport logic to respond to the address indicated on the thumbwheel.
WRITE ENABLE/WRITE LOCK (rocker switch)	SW4	<p>Placing this switch in the WRITE ENABLE position lights the WRITE indicator and allows a write operation.</p> <p>Placing this switch in the WRITE LOCK position turns off the WRITE indicator and prevents a write operation.</p>
REMOTE SELECT (indicator)	L2	<p>Lights when the transport is in the remote (on-line) mode and is selected by the controller.</p> <p>Goes off when the transport is in the off or local (off-line) modes or is deselected by the controller.</p>
WRITE (indicator)	L1	<p>Lights when the WRITE ENABLE/WRITE LOCK switch is in the WRITE ENABLE position.</p> <p>Goes off when the WRITE ENABLE/WRITE LOCK switch is in the WRITE LOCK position.</p>

1.4.2 Tape Motion System

Each half of the dual tape motion system (Figure 1-2) consists of: two ac induction reel motors (mounted behind the hinged mounting panel), two tape reel hubs, a tape guide assembly, and a read/write head. Tape motion from the supply reel, over the tape guides and read/write head, and onto the take-up reel is directly controlled by the two 600-rpm induction reel motors that drive the reel hubs. The solid state switching circuits that control the reel motors govern the amount of torque applied to each motor. For forward tape motion, full torque is applied to the forward motor (take-up reel) and reduced torque is applied to the reverse motor (supply reel). This condition establishes the direction of the tape motion and maintains the proper tape tension without the use of capstans, pinch rollers, or drag pads. Similarly, the opposite reel motor conditions are necessary for reverse tape motion.

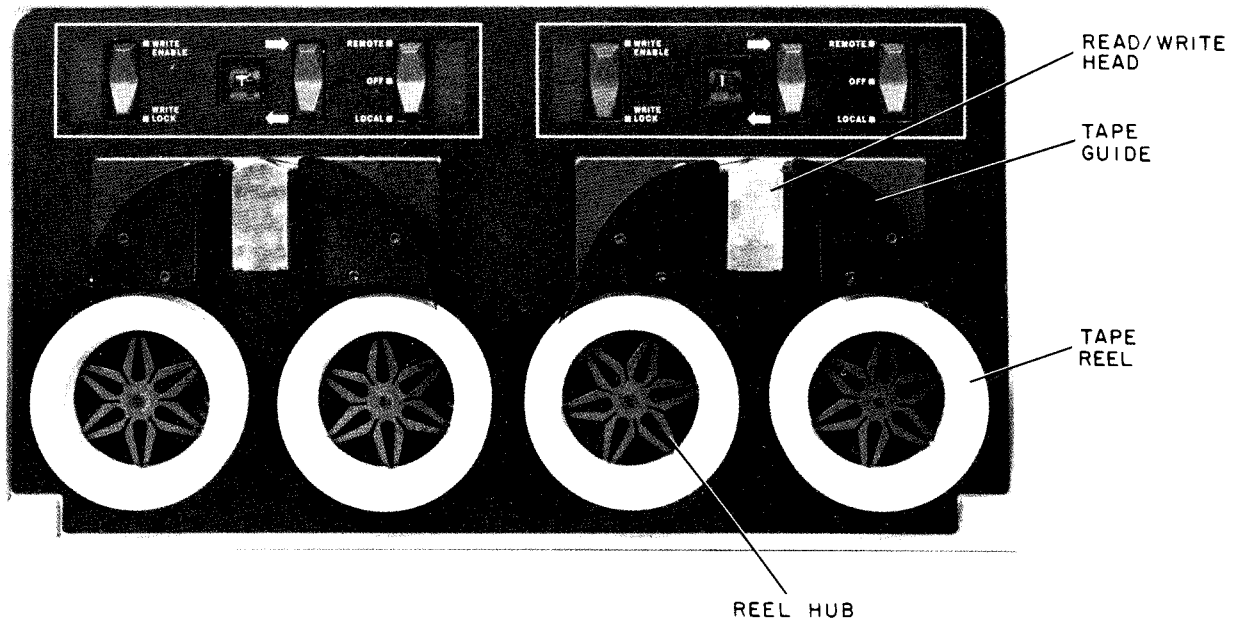

A. Mounting Panel (closed)

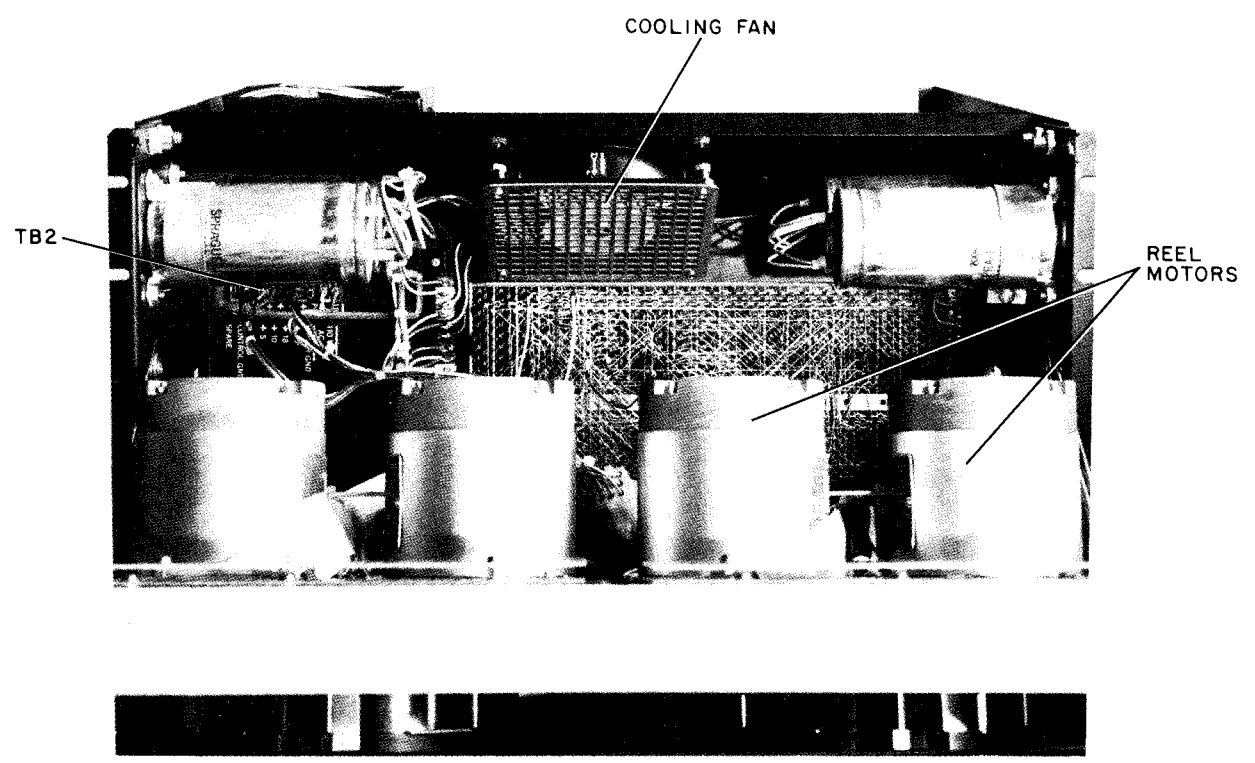

B. Mounting Panel (opened)

Figure 1-2 Tape Motion System

Since a separate track containing timing information plus a Manchester Phase encoding technique is used, tape speed can vary as much as ± 20 percent without affecting the read/write reliability. Dynamic braking of the reverse motor causes a positive stop without adverse tape backlash. Whenever the tape is motionless, both motors apply partial torque to maintain the tape position.

NOTE

During tape motion, the high harmonic content of the 40-Hz square wave that supplies the tape reel motors produces small, cyclic variations in the power output of the motors. These variations cause an audible hum which varies in intensity as the reel being driven by a particular motor fills with tape. Such behavior is normal and has no effect on the performance of the transport.

1.4.3 Power Supply

The H725 Power Supply, located in the left rear portion of the transport cabinet (Figure 1-3), furnishes +18 and +38 Vdc operating power for the reel motors only. A convenience outlet on the back of the supply furnishes 110/220, 50/60 Hz ac power. AC operating power for the cooling fan is obtained directly from the input line voltage, through terminal connector TB2 located on the front of the power supply. The +5 Vdc logic operating power is supplied by either an external source or is generated internally by a voltage regulator on the G859 Clock and Regulator module. When +10 Vdc is connected to TB1 (+10 terminal) of the power supply, the regulator reduces this external level to +5 Vdc for internal use. When +5 Vdc is connected to TB1 (+5 terminal), the regulator is bypassed and the external level is directly used internally. For this reason, it is important that the external dc power connection be made to the correct TB1 terminals.

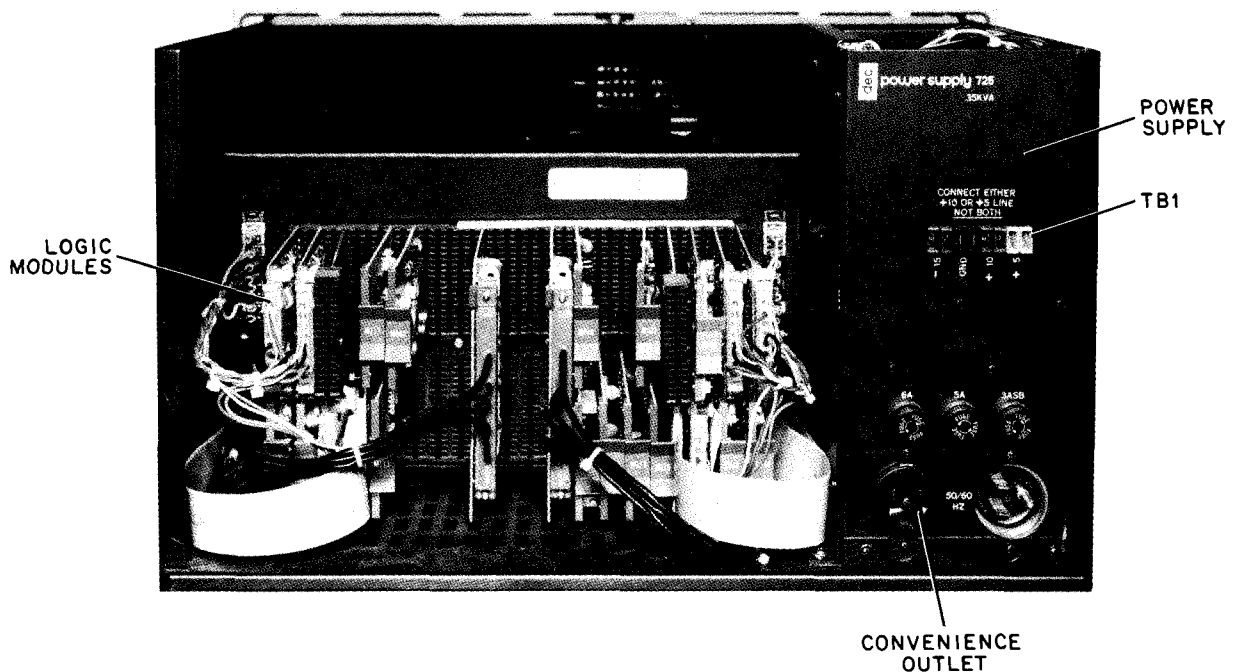

Figure 1-3 Power Supply Location



CHAPTER 2

INSTALLATION

2.1 UNPACKING AND INSPECTION

Do not drop or subject the transport to unreasonable impact. Carefully unpack the TU56 DECTape Transport as follows:

1. Open the outer carton (Figure 2-1) and remove the top four toro pad cushions.

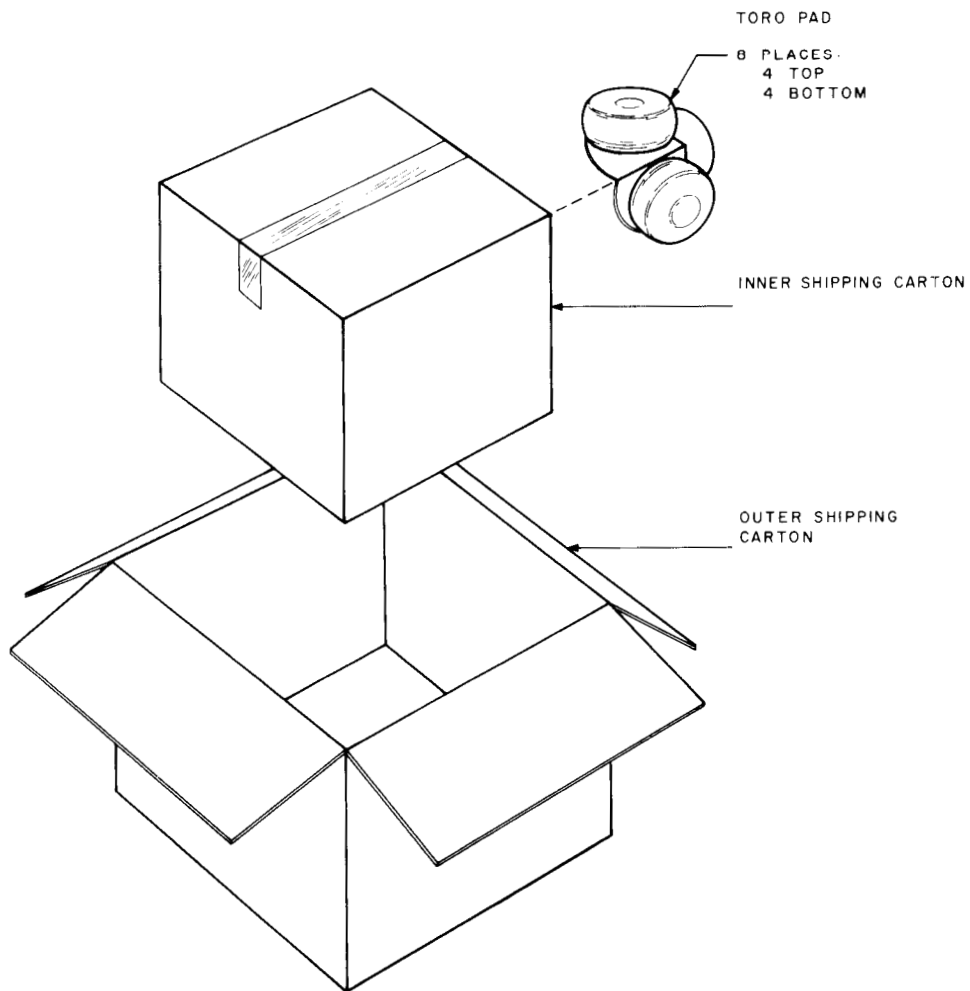

CP-0280

Figure 2-1 Outer Packaging

2. Lift out the inner carton and open it (Figure 2-2).
3. Remove the back and side support laminated pieces.
4. Lift the transport out of the inner carton and unbolt the shipping bracket. Replace the shipping bracket screws in the transport chassis and retain the packing materials for possible return shipment.
5. Inspect the transport and report any damage to the carrier and Digital Equipment Corporation.

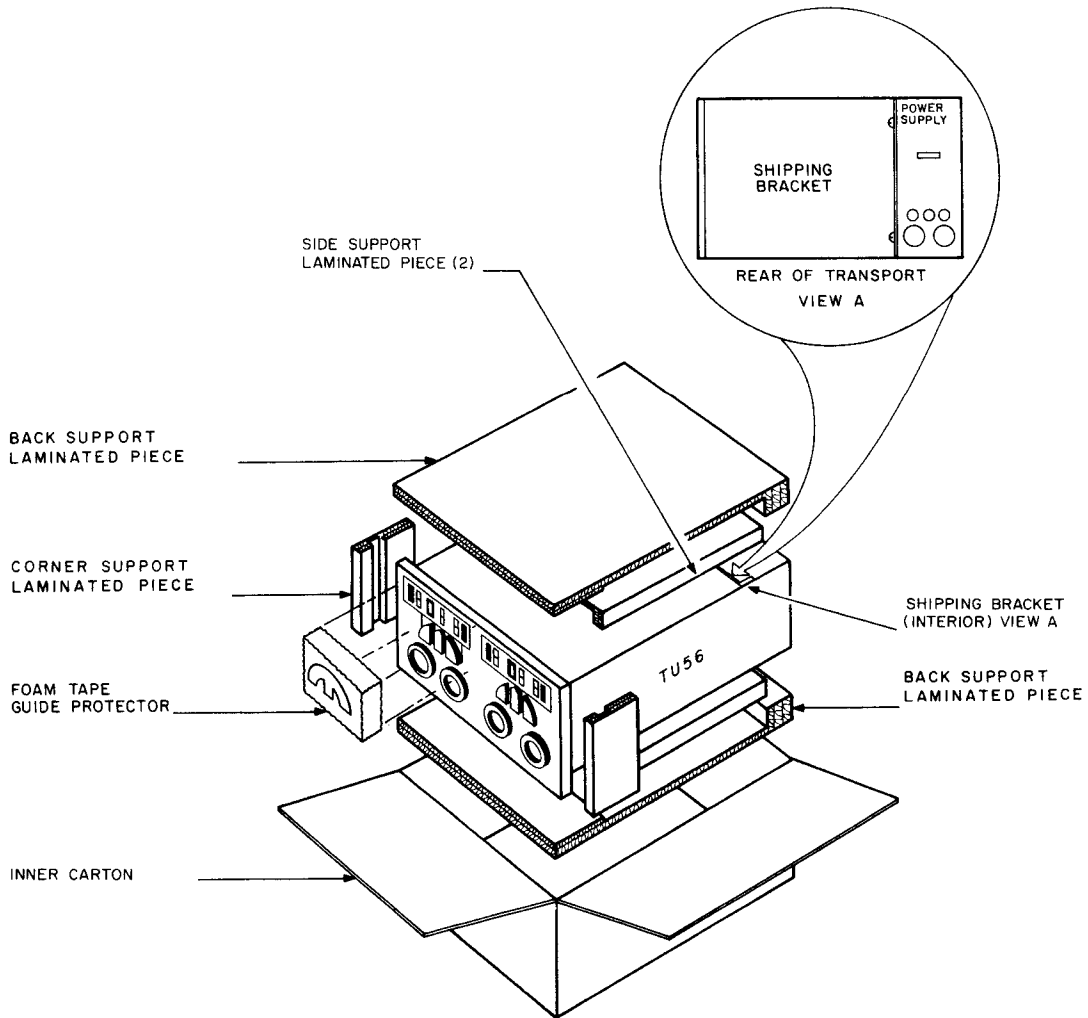

CP-0282

Figure 2-2 Inner Packaging

2.2 MECHANICAL INSTALLATION

To install the TU56 DECTape Transport in the cabinet, two different mounting support brackets are available. The mounting support plate bracket with spacer blocks (7408321 and 7408322) is for transport installation in an H950 cabinet. The U-shaped spacer support bracket (7408009) can be ordered separately and is for transport installation in a tubular-type cabinet. The following paragraphs describe the bracket installation procedures for both cabinet types.

2.2.1 Mounting Support Plate Bracket and Spacer Block Installation

1. Place the mounting support plate (7408321) in the H950 cabinet and secure it to the front of the cabinet mounting rails (Figure 2-3).
2. Install the spacer blocks and secure them to the side of the cabinet mounting rails.
3. Secure the spacer blocks to the mounting support.

2.2.2 Spacer Support Bracket Installation

1. Place the spacer support bracket (7408009) in the tubular cabinet and secure it to the cabinet front with the mounting hardware (Figure 2-4).
2. Attach four clip-on speed nut fasteners to the spacer support bracket.

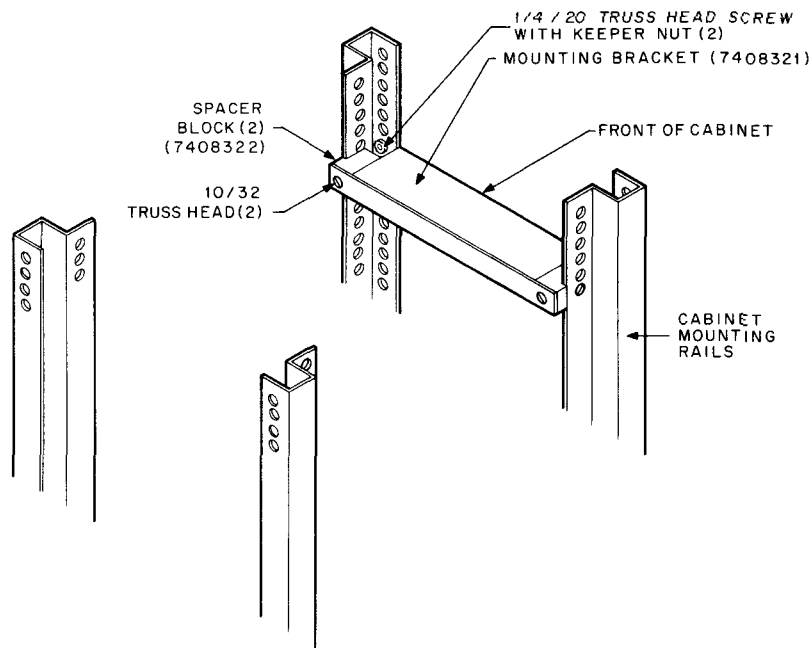
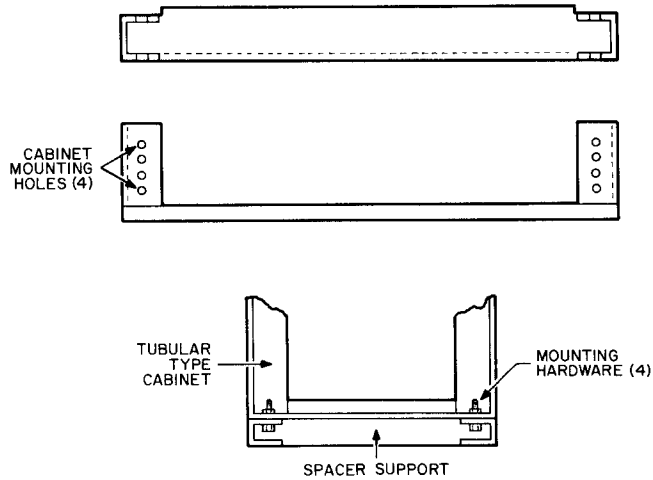

Figure 2-3 H950 Cabinet Support Plate



SP-0281

Figure 2-4 Tubular Cabinet Spacer Support Bracket

2.2.3 Transport Installation

The tape transport may be installed in a cabinet without removing the transport mounting panel; however, the mounting panel weight makes this practice difficult. It is best, as described in the following procedure, to first remove the mounting panel, then install the transport.

1. Remove the M922 Ribbon Cable Connectors from slots B04 and B17 of the logic module mounting block at the rear of the transport (Figure 2-5A).
2. Disconnect the 22-pin Amphenol head cable connector from the rear of the G851 Relay modules in slots AB09 and AB12.
3. Turn the mounting panel side locking fasteners (Figure 2-5B) one-quarter turn to unlock the mounting panel.
4. Carefully lower the mounting panel until the support struts are fully extended (Figure 2-5C).
5. Disconnect the reel motor cable connectors (Figure 2-5C) by pressing the locking tabs, which extend from one of the Mate-N-Lok connectors, against the side of the connector body and separating the connector halves.

NOTE

If the reel motor connectors are held to the chassis by a nylon cable holder, remove the top of the holder and free the cable.

6. Route the head and ribbon cables from the back to the front of the transport.
7. Support the mounting panel and remove the support strut mounting screws.
8. Tilt the mounting panel slightly upward, pull it forward, then lift up the rear to free it from the transport.
9. Mount the transport in the cabinet with four Phillips No. 10-32 truss-head screws and keeper nuts.
10. Reinstall the mounting panel by performing Steps 1 through 8 in reverse.

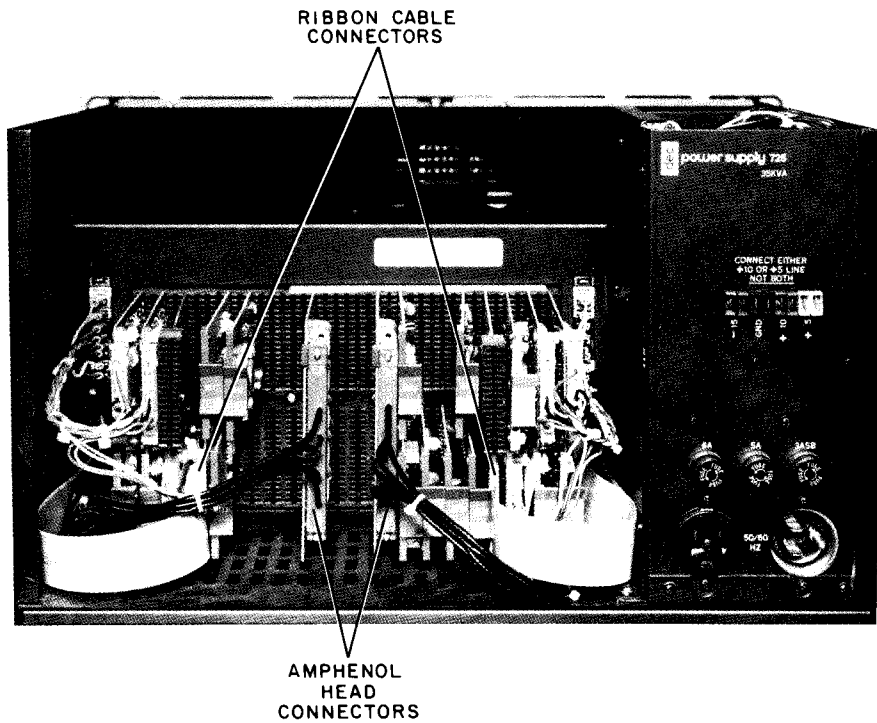

A. Transport Rear View

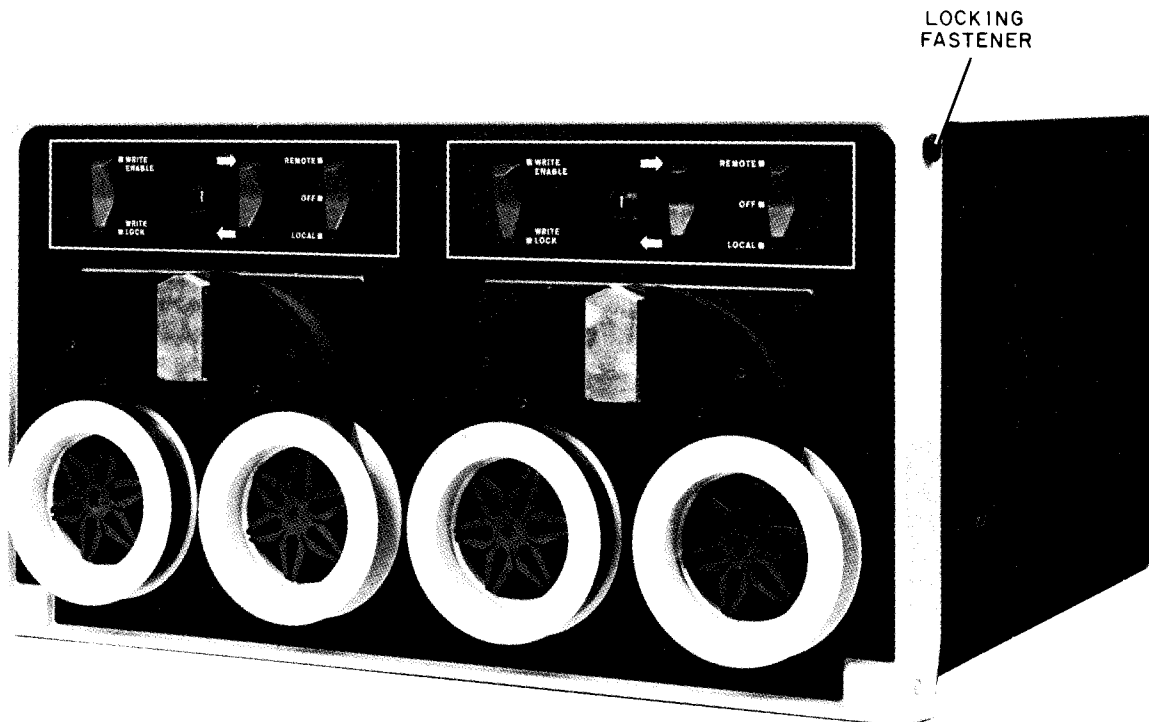

B. Locking Fastener Location

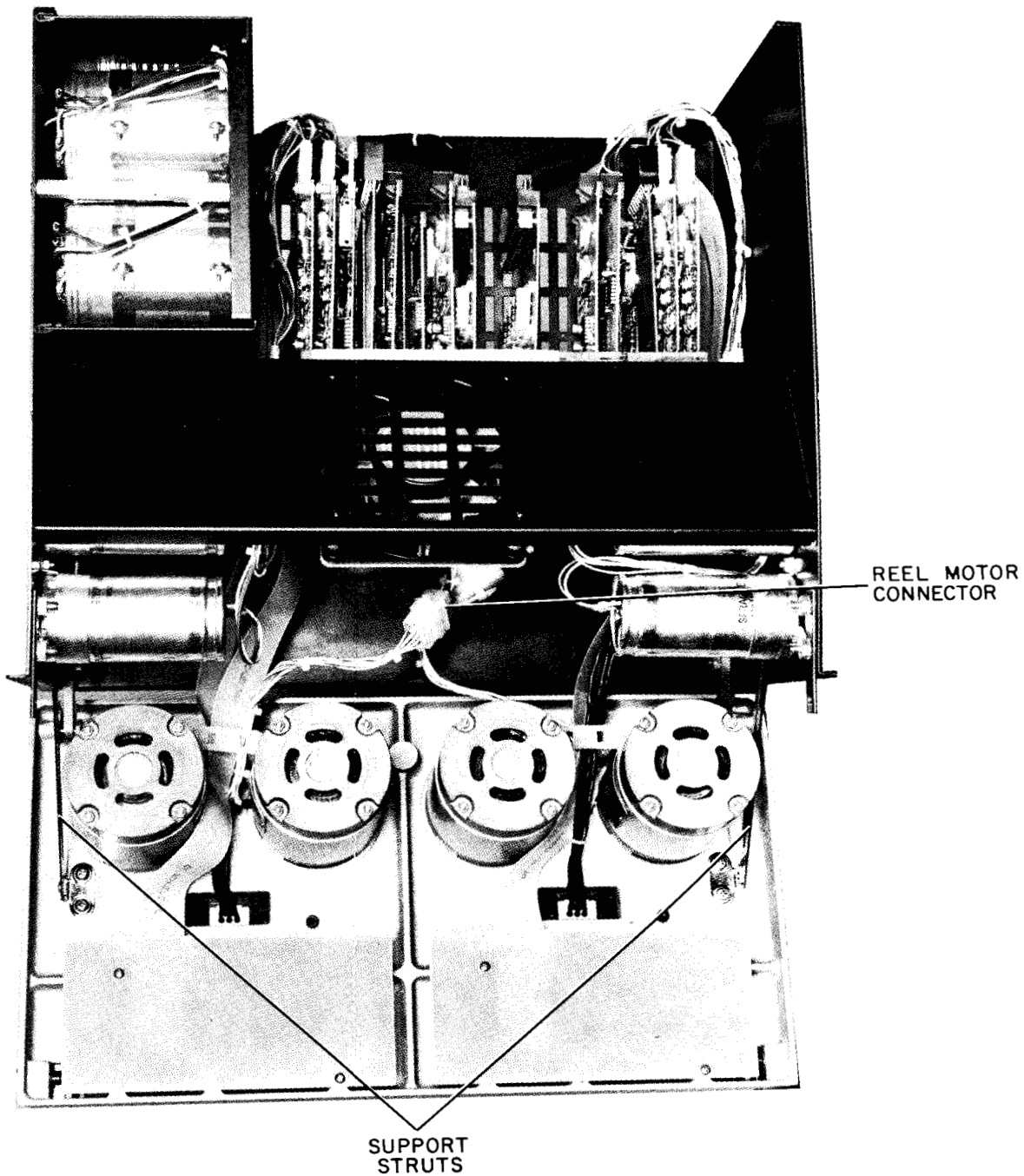

C. Mounting Panel Opened

Figure 2-5 Faceplate Removal

2.3 ELECTRICAL INSTALLATION

1. After the transport has been installed in the rack (Paragraph 2.2.3), visually inspect the cables and logic modules to ensure that the modules are securely seated in the correct slots of the logic mounting block. (Refer to Drawing MU-TU56-0-MU for the correct logic module and slot locations.)
2. Connect the appropriate interface cables (Table 2-1) to the logic mounting block and ensure that the correct interface modules for the corresponding controller type (Table 2-2 and Drawing MU-TU56-0-MU) are installed.

**Table 2-1
TU56 and TU56H Interface Cabling**

Cable Origin	Command Cable Termination (Slots A06/A07)	(1) Information Cable Termination (Slots AB10/AB11)
TD10 TC01 TC02 TC08 TC09 550 551 552	M908B Module, 70-06223 Cable	W032 Module, 74-5152 Cable
TU56	M908B Module, BC-02X Cable	W032 Module, 74-5152 Cable
TU55	M908B Module, 70-06223 Cable	W032 Module, 74-5152 Cable
TC15	M908B Module, BC-02X Cable	W032 Module, 74-5152 Cable
TC11	M908B Module, BC-02X Cable	W032 Module, 74-5152 Cable
TD8/e	(2) 70-08447 Cable	(2) 70-08447 Cable

(1) For a TU56M or TU56MH Transport: controller-to-transport information cable = 70-06412, transport-to-transport (other TU56 or TU56H in system) information cable = 74-5152. See Note 2 for TU56M or TU56MH connected to a TD8/e Controller.

(2) When a TU56M or TU56MH is connected to a TD8/e Controller, only one 70-08447 cable is used for both commands and information. This cable has both a single-height and a double-height connector module on the termination end. Insert the single-height connector into slots A06/A07 and the double-height connector into slots AB10/AB11.

3. Check the clearance between each reel hub and the flange on the mounting panel (Figure 2-6) with the feeler gauge supplied with the transport. If the gauge does not fit, loosen the Allen screws on the hub and make the necessary adjustment. Retighten the Allen screws.

CAUTION

Do not repeatedly loosen or tighten the hub Allen screws. These screws are serrated cup type and may become damaged with excessive use.

(continued on Page 2-8)

Table 2-2
Interface Module Substitution

Control Type	Required Module	Quantity	Position in Mounting Block	Logic Level
Integrated Circuit	G742	1	A05	F = 0
	M941	2	A18, A04	T = +5
Relay	W513	2	A04, A18	F = open
	M531	1	A05	T = closed
Solid State	M941	2	A04, A18	F = 0
	M531	1	A05	T = -3

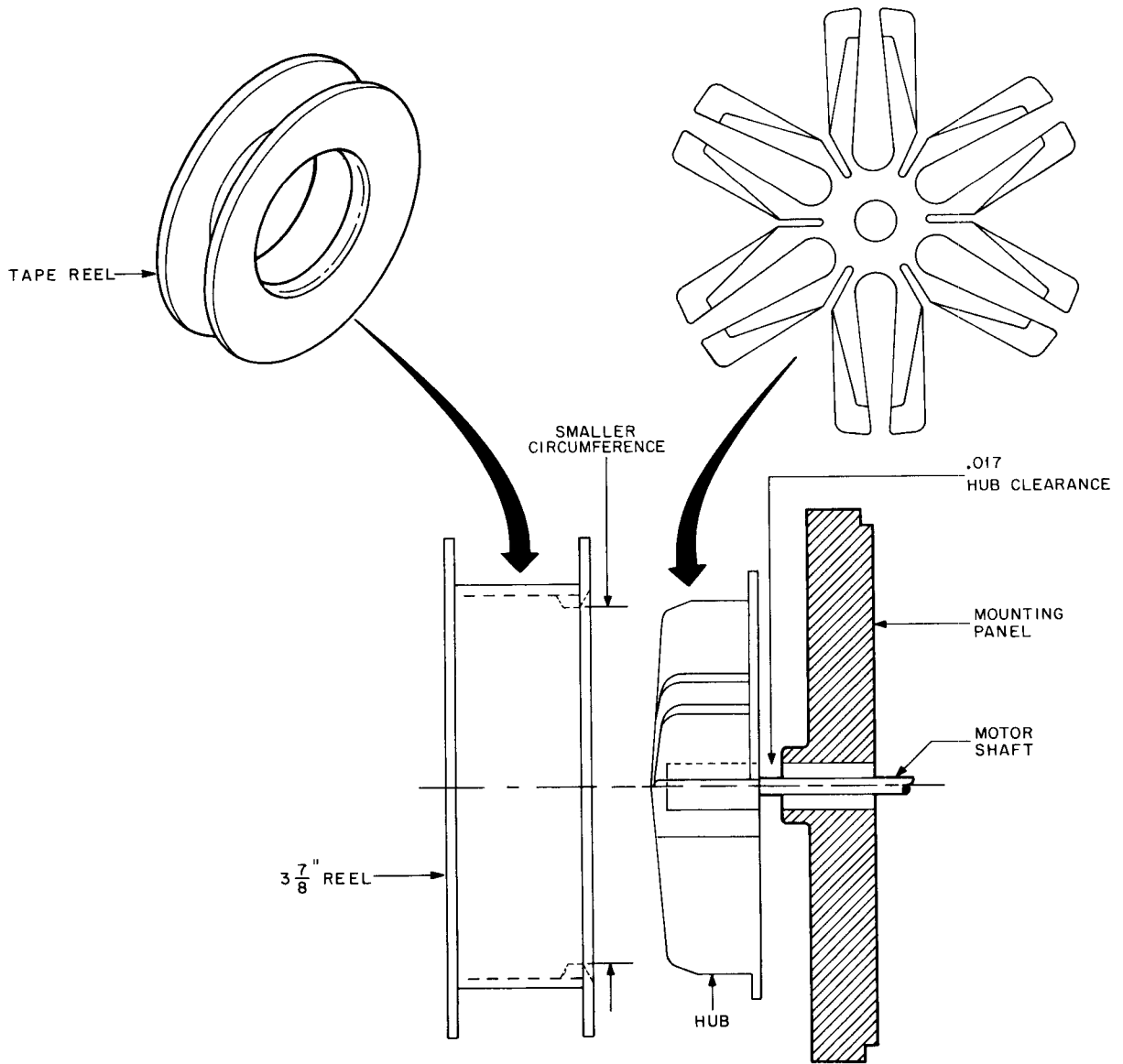

10-0178

Figure 2-6 Hub and Reel

4. Check the transformer tap connections of the H725 Power Supply (Drawing CS-725-0-1) to ensure that the power supply is configured properly for the input power to be used.
5. Insert the ground, -15, and +10 or +5 Vdc spade lugs into the proper TB1 terminals on the rear of the power supply.
6. Plug the power cord into the ac line receptacle.
7. Load a tape (Paragraph 2.4.1) and operate the transport in the local mode to ensure proper electrical and mechanical operation.

2.4 OPERATION

2.4.1 Tape Loading and Unloading

To load tape, proceed as follows:

1. Set the REMOTE/OFF/LOCAL switch to OFF.
2. Position a full tape reel so that the labeled side is out and the smaller circumference is against the left hub (Figure 2-6). Press the reel fully onto the hub ensuring that the reel is evenly seated (not cocked).

NOTE

If the transport is connected to a PDP-12 system, mount the full reel on the right hub since forward tape motion for the PDP-12 is from right-to-left instead of left-to-right.

3. Mount an empty take-up reel on the right hub as described in Step 2.
4. Route the tape from the left reel, over the tape guides and read/write head, to the right side of the take-up reel.
5. Hold the free tape end against the take-up reel hub and rotate the take-up reel clockwise, winding four or five turns of tape onto the reel.
6. Verify that power is applied to the transport and set the REMOTE/OFF/LOCAL switch to LOCAL.
7. Press and hold the Forward switch (→) for about 3 seconds, allowing approximately 15 turns of tape to wind onto the take-up reel. (Press the Reverse switch (←) for a PDP-12 system.) This action ensures that the data portion of the tape is positioned over the read/write head.

To unload tape, proceed as follows:

1. Set the REMOTE/OFF/LOCAL switch to LOCAL.
2. Press and hold the Reverse switch (←) until the tape has completely rewound onto the left supply reel (right supply reel for a PDP-12 system).
3. Set the REMOTE/OFF/LOCAL switch to OFF and remove the supply reel.

2.4.2 On-Line Operating Procedures

1. Verify that power is applied to the transport and load the appropriate tape (Paragraph 2.4.1).
2. Set the Address Select switch of the transport to be used to the desired address and position the WRITE ENABLE/WRITE LOCK switch as desired.
3. Set the REMOTE/OFF/LOCAL switch to REMOTE.

CHAPTER 3

THEORY OF OPERATION

3.1 INTERFACE

Standard interface connection of the TU56 DECTape Transport is made with an information cable to slots AB10 or AB11 and a command cable to slots A06 or A07 of the logic mounting block. (Refer to Table 2-1 for the controller model and corresponding interface cable type, and Table 2-2 for the module substitutions.) These connector slots are parallel-wired so that up to eight transports may be serially connected in a multi-transport "daisy chain" configuration (i.e., connectors AB10/AB11 and A06/A07 of the first transport are connected in series to connectors AB10/AB11 or A06/A07, respectively, of the following transport, etc.).

If the TU56 is connected to a TC08 Controller, the following logic considerations must be understood. Command signals leave the controller M623 Bus Driver module via a 70-06223 cable. In the transport, these signals pass through an M941 Jumper module to an M531 Bus Converter module. If the input to the controller M623 module is ground, the output is ground; if the input is +3V, the output is -3V. The M531 module in the transport has the input/output requirements reversed from those of the M631. That is, a ground input produces a ground output; however, a -3V input produces a +3V output.

Figure 3-1 illustrates the TC08 to TU56 logic connection. If BMR 01 (1) L is true, GO H is false. To maintain compatibility between the various available controllers and the transport, signals such as CON GO, CON STOP, CON REV REM, and CON FWD REM are reversed inside the 70-06223 cable (i.e., the actual signal appearing at point 2 in Figure 3-1 is T STOP L). For this reason, the 70-06223 cable must not be installed backwards. If the cable is reversed, the system will not operate.

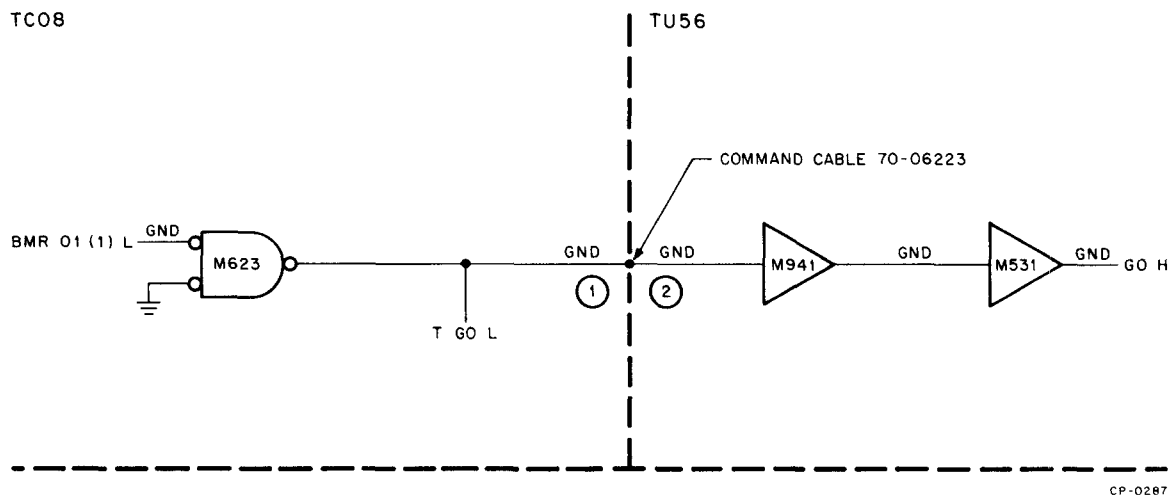

Figure 3-1 TC08 to TU56 Logic Connection

Figure 3-2 illustrates and the following paragraphs describe the function of each interface line when the transport is connected to a solid state controller with logic levels of $-3V = T$ and ground = F.

3.1.1 Input Interface Lines – Command Cable – A06/A07

3.1.1.1 Select 0–7 – These eight lines and the eight-position Address Select thumbwheel on the control panel determine the transport address assignment and selection. In a particular transport, only one of these lines is internally connected (via the Address Select switch) to the transport select logic. In order to select a transport, the controller places a ground level on the desired SELECT line. This line then remains at ground during the entire read, write, or control operation. When the transport is not selected, the SELECT line is at $-3V$.

3.1.1.2 CON STOP – This line transmits a signal to stop tape motion. The controller places a $-3V$ level on this line to reset the Motion L flip-flop and thus terminate tape motion. (CON GO and CON STOP are complementary signals.)

3.1.1.3 CON GO – This line transmits a signal to initiate tape motion. The controller places a $-3V$ level on this line to set the Motion L flip-flop. During normal operation, a CON REV REM or CON FWD REM signal must accompany this signal. (CON STOP and CON GO are complementary signals.)

3.1.1.4 CON REV REM – This line transmits a signal to designate reverse tape motion. The controller places a $-3V$ level on this line to reset the Direction L flip-flop and thus reverse tape motion. During normal operation, a CON GO signal must accompany this signal. (CON REV REM and CON FWD REM are complementary signals.)

3.1.1.5 CON FWD REM – This line transmits a signal to designate forward tape motion. The controller places a $-3V$ level on this line to set the Direction L flip-flop and thus initiate forward tape motion. During normal operation, a CON GO signal must accompany this signal. (CON FWD REM and CON REV REM are complementary signals.)

3.1.1.6 CON ALL HALT – This line transmits a signal to stop tape motion whenever the computer program is halted. If the computer program halts, either by instruction or operator intervention while the tape is in motion, the tape would continue to run off the reel. To prevent this, the controller places a $-3V$ level on this line to reset the Motion L flip-flop whenever the computer program halts.

3.1.1.7 CON PWR UP DLY – This line transmits a signal to prevent tape motion while initial power is applied to the computer. During the computer power-on sequence, the controller places a ground level on this line that applies a $+18V$ brake signal to both reel motors. When the computer is successfully powered-up, this line goes to $-3V$.

3.1.2 Output Interface Lines – Command Cable – A06/A07

3.1.2.1 Select Echo – This line transmits an analog signal to indicate the transport selection status. When the transport is in the remote mode, a -6 to $-9V$ signal on this line indicates that only one transport has been properly selected. A $0V$ signal indicates that no transport has been selected. A -9 to $-15V$ signal indicates that more than one transport has been selected. (Refer to Paragraph 3.4.2.1 for a detailed description.)

3.1.2.2 Write Echo – This line transmits a signal to indicate the transport “write protect” status. If the transport is write protected (write capability inhibited), this line is at $-3V$. If the transport is not write protected, this line is at ground.

3.1.3 Bi-Directional Interface Lines – Information Cable – AB10/AB11

3.1.3.1 Timing Track (TT) – This line transmits timing pulses to or from the transport timing tracks.

3.1.3.2 Mark Track (MT) – This line transmits mark channel information to or from the transport mark tracks.

3.1.3.3 Data Tracks (D0–D2) – These lines transmit data or control words to or from the transport data tracks.

3.2 FUNCTIONAL INFORMATION

Since the TU56 DECTape Transport is a dual system, each transport contains identical logic. Figure 3-2 is a functional block diagram of only the left (L) transport logic. The following paragraphs describe the detailed logical operation of the left transport when it is connected to a negative logic ($T = -3V$, $F = 0V$) controller. The right (R) transport operates in an identical manner as the left and is therefore not described.

3.2.1 Read/Write Head

The recording device (read/write head) contains ten read/write coils which are electronically connected in non-adjacent pairs. When the tape is loaded, each coil covers a narrow path along the tape (Figure 3-3). Since it is possible to write in the data tracks (inner tracks) and simultaneously read from the timing and mark tracks (outer tracks), the timing and mark coils are slightly separated by additional shielding from the data coils. During a write operation (Paragraph 3.4.4), each coil pair records identical information. During a read operation (Paragraph 3.4.5), the output from the coil pairs is connected in series to differential amplifiers. Since the differential amplifiers use a zero-crossing detection scheme, the effects of amplitude changes over a wide range are negligible. The analog sum of the coil pair signals determines the correct value (either logical 1 or 0) of the recorded bit. Thus, for a read operation, information from one track combines with redundant information from another non-adjacent track to generate a single channel output signal. This redundant read/write scheme greatly reduces the possible loss of recorded information due to foreign matter on the tape or head. In addition, the pairing of non-adjacent tracks minimizes the adverse effects of tape skew.

3.2.2 DECTape Format

The TU56 Transport uses the standard DECTape formatted tapes, furnished by DEC, as a storage medium. These blank tapes are supplied with the timing and mark tracks prerecorded at the factory by a write head with zero skew. Consequently, these tapes may be used on any transport where the head skew is within specifications. The timing and mark tracks can also be recorded on used tape by a customer tape system. However, unless the customer write head has less than a 200-micron skew, it is possible that the formatted tapes generated on a customer transport may not be interchanged among all other transports.

There are ten tracks across the 3/4-inch wide DECTape (Figure 3-3). The two outer tracks (timing tracks) are electronically paired to form one timing channel that is used to synchronize and control read/write operations. The timing track is prerecorded with alternating positive (TP0) and negative (TP1) flux reversals at a fixed frequency. During a write operation, these alternating flux reversals are read from the timing track. The positive flux reversal (TP0) loads the data to be recorded into a write buffer in the controller for transfer over the data lines. The negative flux reversal (TP1) complements the write buffer and by so doing, reverses the write current

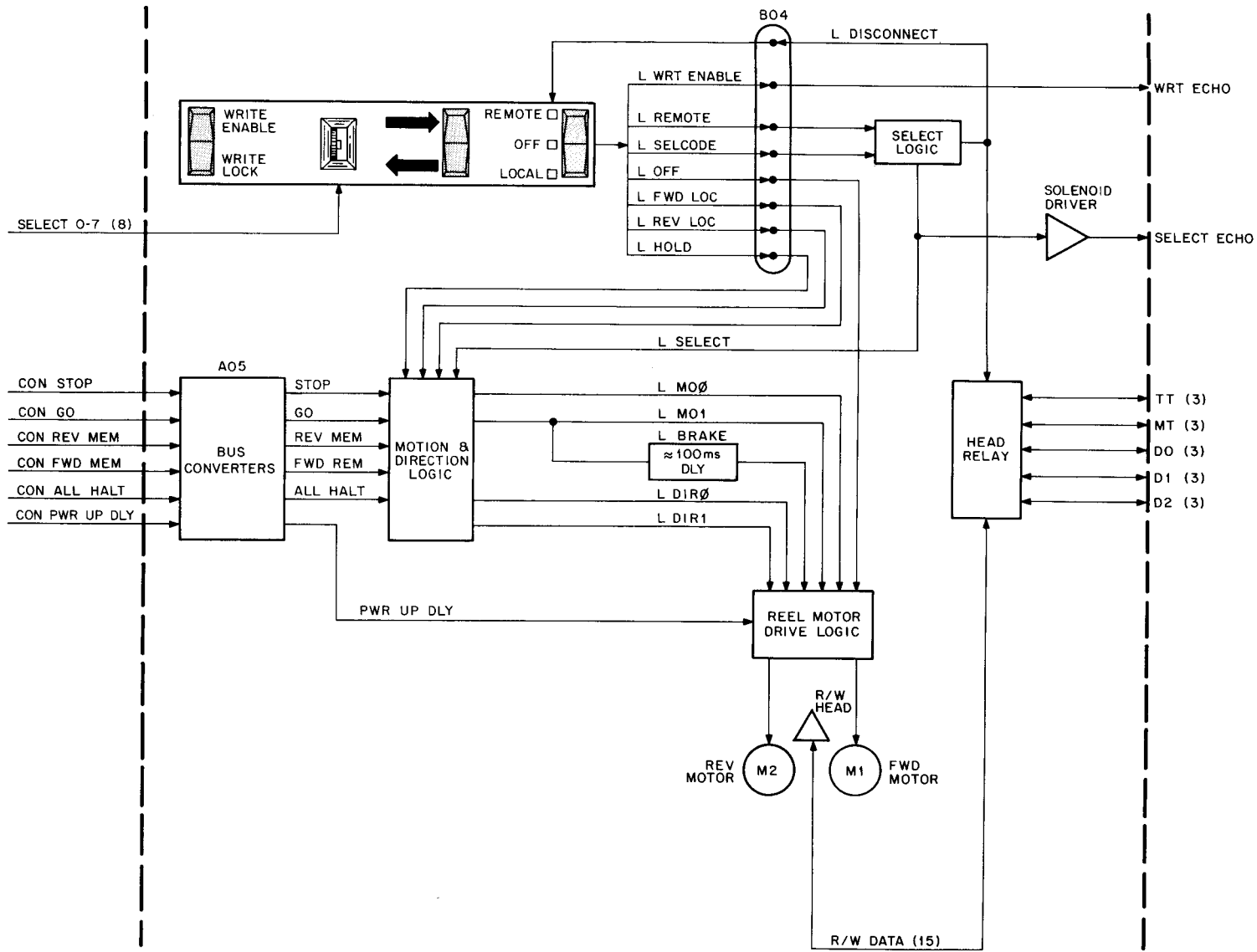

CP-0285

Figure 3-2 Functional Block Diagram

in the write coils. Thus, if a 0 is to be written, the write current is switched negative, resulting in a negative flux reversal on the tape. Conversely, if a 1 is to be written, the write current is switched positive. During a read operation, TP1 generates a strobe within the controller that allows sampling of the data lines during peak data signal amplitudes.

The two tracks directly adjacent to the timing tracks (mark tracks) are paired to form a mark channel that designates the type of information (either control or data words) contained in the data tracks. A unique 6-bit code in the mark track identifies the tape location (e.g., beginning of block, end of block, data, etc.) and the type of information stored at that location. Since a read or write operation can be performed while the tape is moving forward or reverse, the mark track bits, when decoded, are identical (symmetrical) for data read from either direction. In addition to being symmetrical, the mark track codes are designed so that a single bit error can not change one valid code into another.

The six inner tracks (data tracks) are grouped at the center of the tape where they are least affected by tape skew. These six tracks are coupled to form the three data channels. A control word in the data channel is six frames long (as determined by the 6-bit mark track code) and contains 3 bits per frame (18 bits total). These control words store address and checking information and provide compatibility between computers using 12, 16, 18, 32, or 36-bit words. A data word in the data channel contains stored information and occupies at least four 3-bit frames (12 bits).

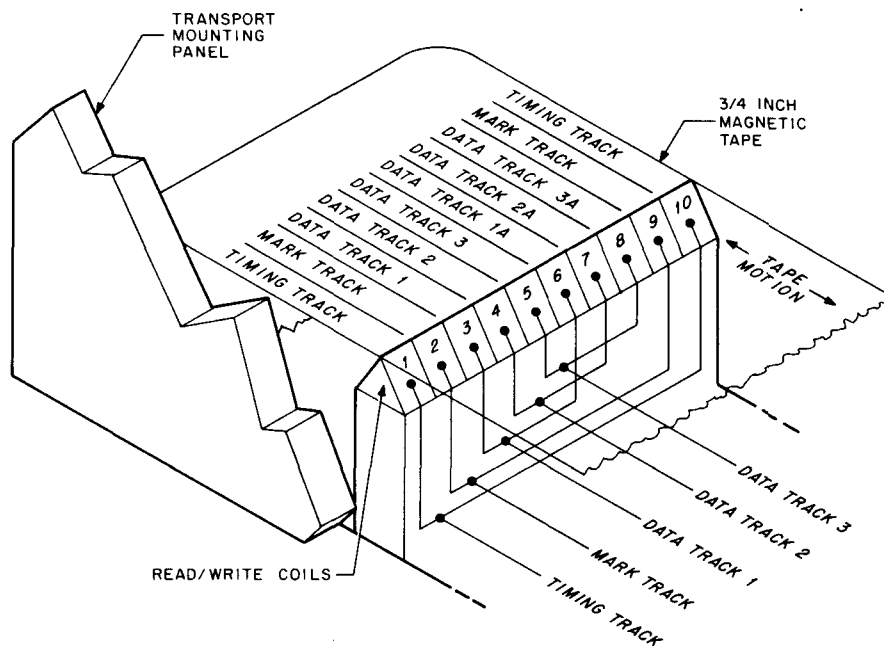

NOTE:
Each coil pair is actually wired in series, with two wires connected to a differential amplifier. However, for simplicity, only a single wire from each pair is shown.

CP-0284

Figure 3-3 Read/Write Head Arrangement

3.3 LOCAL (off-line) OPERATION

Figure 3-4 illustrates and Paragraphs 3.3.1 through 3.3.3 describe the logical sequence of events during off-line manual operation of the transport.

3.3.1 Forward Tape Motion

Placing the REMOTE/OFF/LOCAL switch SW2 (Drawing BS-TU56-0-TLD, sheet 2) on the control panel in LOCAL, applies ground to the center wiper of the Forward/Hold/Reverse switch SW3. If the spring-loaded SW3 switch is pressed and held in the Forward position, L FWD LOCAL (Drawing BS-TU56-0-TLD, sheet 1) goes low and is applied to both pin H1 of the M117 Direction L flip-flop, and pin B1 of the Motion L flip-flop. This action sets both flip-flops, generating the L MO1 and L DIR1 high signals. These signals are then ANDed at gate M113 pins P1 and R1. The low M113 pin S1 output is inverted high and applied to the G847 module, then applying a +38V run signal to the forward motor. Simultaneously, input pin N2 of the G847 module goes low, applying a +18V drag signal to the reverse motor.

When SW3 is released, the center wiper returns to the Hold position. This action generates the L HOLD low signal, terminating tape motion.

3.3.2 Hold Tape Motion

Placing the REMOTE/OFF/LOCAL switch SW2 (Drawing BS-TU56-0-TLD, sheet 2) on the control panel in LOCAL, applies ground to the center wiper of the Forward/Hold/Reverse switch SW3. With SW3 in the spring-loaded Hold position, L HOLD (Drawing BS-TU56-0-TLD, sheet 1) goes low and is applied to inverter G859 pin K2, generating L RESET low.

If forward tape motion is occurring when the Hold switch is enabled, L RESET, when applied to pin E2 of the M117 Motion L flip-flop, resets the flip-flop generating L MO1 low. This action triggers the 100-millisecond L Brake one-shot to produce the L BRAKE high signal. L BRAKE and L MO0 (high because the Motion flip-flop is now reset) are ANDed with L DIR1 at gate M117 pins T2, S2, and R2. The low M117 pin V2 output is inverted high and applied to the G847 module, thus applying a +38V brake signal to the reverse motor.

If reverse tape motion is occurring when the Hold switch is enabled, L DIR0 is high and the +38V brake signal is applied to the forward motor.

If no tape motion is occurring when the Hold switch is enabled, the Motion flip-flop is already reset when L RESET is produced. Consequently, the L Brake one-shot is not triggered and the L BRAKE signal is not produced. If this occurs, the outputs from inverters M113 pins K1 and K2 are both low, and +18V drag signals are simultaneously applied to both the forward and reverse motors. Thus, tape tension is retained while the tape is motionless.

3.3.3 Reverse Tape Motion

The logical sequence for reverse tape motion is similar to forward tape motion except that L REV LOCAL resets the Direction L flip-flop, causing the +38V run signal to be applied to the reverse motor and the +18V drag signal to be applied to the forward motor. (Refer to Paragraph 3.3.1 for a detailed description of forward tape motion.)

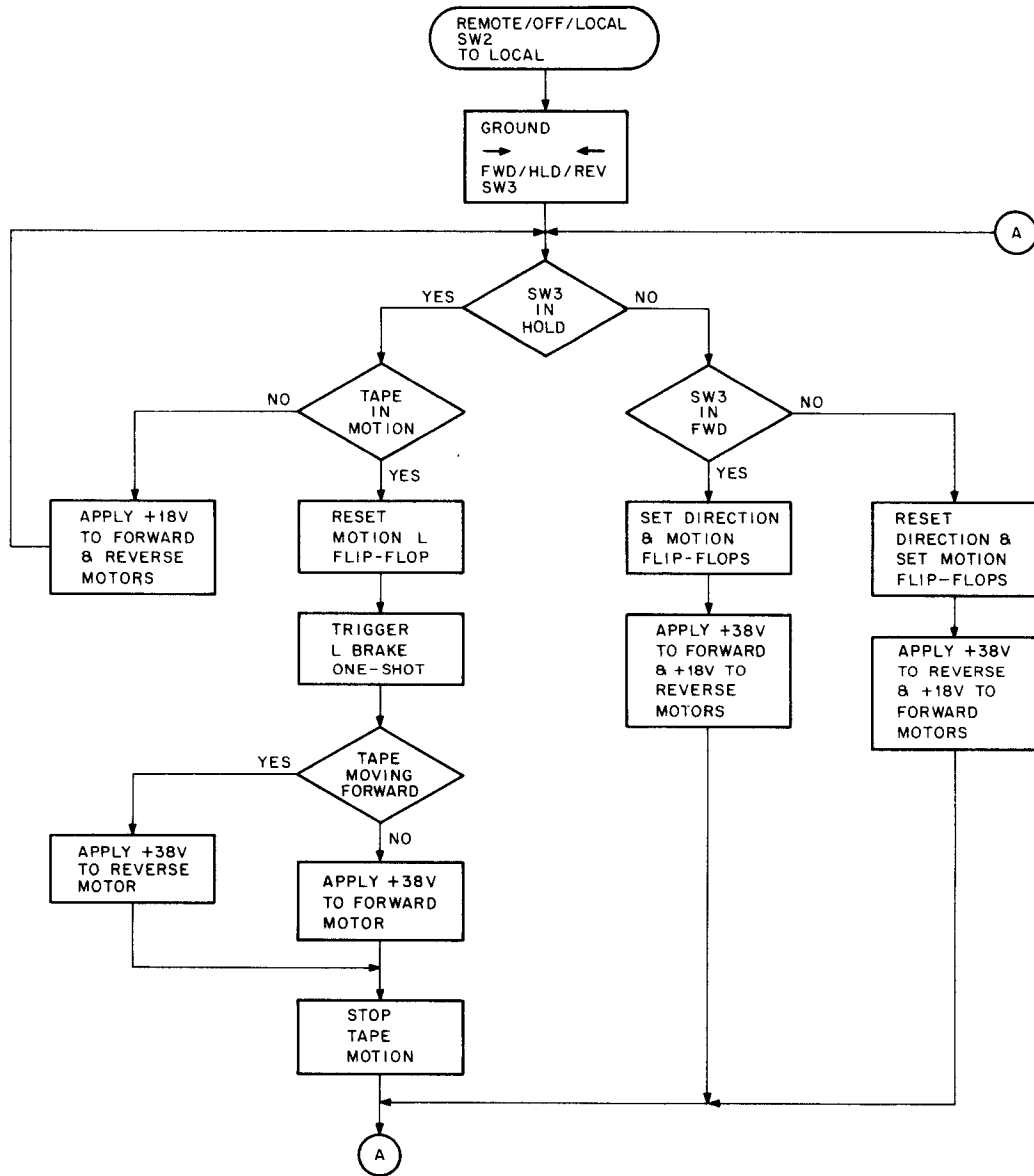

CP-0283

Figure 3-4 Off-Line Manual Operation Flow Chart

3.4 REMOTE (on-line) OPERATION

The actual remote transport operation is relatively simple, however, a minimal explanation of the controller operation is also included in the following description. This additional controller explanation is necessary for a comprehensive understanding of the overall system operation. If the transport is connected to a controller other than the one previously described (Paragraph 3.1), optional logic converter modules as indicated in Table 2-2 and on the logic drawings must be used.

3.4.1 Tape Transport Addressing

For greater flexibility in a multi-transport system, the transport address can be changed by changing the position of the Address Select thumbwheel SW1 (Drawing BS-TU56-0-TLD, sheet 2) on the control panel. The eight SELECT interface lines (numbered 0 through 7) are directly connected to the contacts of the correspondingly numbered SW1 switch positions. Placing this switch in any one of the eight positions connects the wiper arm to the associated SELECT interface line.

NOTE

On a dual transport (TU56) there are two Address Select switches that function independently. These switches are not interlocked. Therefore, if the operator should inadvertently configure two or more transports for the same address, the controller will detect a select error (Paragraph 3.4.2.1).

The wiper arm output is then applied through an M941 Jumper module (Paragraph 1.3) to pin S2 of the M531 Negative Bus Converter module (Drawing BS-TU56-0-TLD, sheet 1). When the controller applies ground to the appropriate SELECT interface line, L SELCODE goes low. This signal is then applied through inverter M113 pins T2, U2 (Drawing BS-TU56-0-TLD, sheet 2) to M113 pin E1.

If the REMOTE/OFF/LOCAL switch is in the REMOTE position, L REMOTE, applied through inverter M113 pins P2, R2 (Drawing BS-TU56-0-TLD, sheet 1), ANDs with the M113 pin V2 inverter output (Drawing BS-TU56-0-TLD, sheet 2) to generate L SELECT high, plus L DISCONNECT high. The L SELECT high signal allows the transport to perform the various control and read/write operations. The L DISCONNECT high signal energizes the head relays connecting the read/write coils to the interface data lines. In addition, L DISCONNECT is applied to connector M922 pin S1, lighting the REMOTE indicator on the front panel.

3.4.2 Error Checks

If a Write Command is issued to a transport that has not been selected or the transport is write protected, one or both of the echo signals described in the following paragraphs are generated. If this occurs, an error flag signal is produced in the controller which prevents further transport operation until the error is corrected.

3.4.2.1 Select Echo – If a transport has been properly selected by the controller (Paragraph 3.4.1), L SELECT is at ground. This signal, applied to solenoid driver M040 pin J2 (Drawing BS-TU56-0-TLD, sheet 1), produces a negative output at pin S2. The negative M040 pin S2 output, when applied through a 100- Ω resistor, results in a -6 to -9V SELECT ECHO analog signal at A06 pin P1. The analog output at P1 is then transmitted over the interface lines to a transport detector module in the controller. A -6 to -9V input at the transport detector produces a +3V output, indicating that only one transport has been selected.

Selection of more than one transport places the 100- Ω resistors of the respective transport SELECT ECHO circuits in parallel and thus decreases the SELECT ECHO signal level below -9V (-9 to -15V). When this occurs, the output from the transport detector goes to 0V, indicating an error condition.

If no transport is selected, the SELECT ECHO output at A06 pin P1 is 0V. A 0V input at the transport detector also results in a 0V output indicating an error condition. Thus, if the operator inadvertently chooses the same address for more than one transport, or if no transport address is chosen, an error flag is generated in the controller that prevents further tape operation on the affected transports until the selection error is corrected.

NOTE

When the transport is connected to a 550, 551, or 552 controller, the preceding select error detection method is not used and the external 100- Ω resistors are removed.

3.4.2.2 Write Echo – In order to record information on a selected transport, the WRITE ENABLE/WRITE LOCK switch (SW4) on the control panel must be in the WRITE ENABLE position. If this is the case, the left wiper of SW4 (Drawing BS-TU56-0-TLD, sheet 2) closes to complete the L1 (WRITE ENABLE) ground return and light the indicator.

If the transport has been properly selected (Paragraph 4.3.1), the signal L DISCONNECT at M922 pin S1 is at ground. L DISCONNECT at ground applies an approximate ground to the diode/resistor biasing junction of the right SW4 wiper. With this circuit configuration, a slightly positive turn-on voltage is applied to the base of the 2N6531 transistor, causing it to conduct and produce a ground (L WRT ENAB high) at M922 pin A1. Once the 2N6531 transistor conducts, the three D664 diodes form a voltage regulating network to maintain a nearly true ground at pin A1. L WRT ENAB high, applied through the M941 Jumper module (Drawing BS-TU56-0-TLD, sheet 1) to connector A06 pin S1, produces WRITE ECHO high. WRITE ECHO high is then transmitted over the interface lines to the controller, indicating that the selected transport is available for a write operation (not write protected).

If the transport has not been selected, the signal L DISCONNECT is at -15V. L DISCONNECT at -15V applies approximately -13.5V to the diode/resistor biasing junction (Drawing BS-TU56-0-TLD, sheet 2). With this circuit configuration, a negative cut-off voltage is applied to the base of the 2N6531 transistor, allowing current flow through the 12K emitter resistor to produce -3V (L WRT ENAB low) at M922 pin A1. Similarly, if the WRITE ENABLE/WRITE LOCK switch is placed in the WRITE LOCK position, the L1 indicator is turned off and the diode/resistor biasing junction is completely disconnected, thus producing -3V at M922 pin A1. With pin A1 at -3V, the WRITE ECHO signal is suppressed, preventing the computer from issuing a Write Command to a transport that has not been selected or one that is write protected.

3.4.3 Tape Motion Control

The following paragraphs describe tape motion control for a forward read or write operation. A reverse tape operation is similar to a forward operation except that the opposite command interface conditions are necessary.

To perform a forward read or write operation, the controller first receives a Read or Write Command from the computer. Specific bits within the command structure designate the transport address, the direction the tape is to be moved, and the desired block number. The controller then simultaneously addresses the appropriate tape transport (Paragraph 3.4.1), places a -3V level on the CON GO and CON FWD interface lines, complements the CON STOP and CON REV REM interface lines, and triggers an internal up-to-speed delay which inhibits read data sampling until the tape has reached a sufficient speed for reliable data transfer.

NOTE

It is possible to deselect a transport without stopping the tape motion and then reselect the transport at a later time. If this is the case, the controller does not trigger the up-to-speed delay and data can be transferred as soon as the transport is reselected. This capability requires additional program instruction and is therefore not described in this text.

When CON GO and CON FWD REM go low, they are inverted high by the M531 Bus Converter module (Drawing BS-TU56-0-TLD, sheet 2) and applied to the Motion L and Direction L flip-flops (Drawing BS-TU56-0-TLD, sheet 1). FWD REM and L SELECT are then ANDed at gate M113 pins D2 and E2 to set the Motion L flip-flop and generate L MO1 high. L MO1 and L DIR1 are then ANDed at gate M113 pins P1 and R1. The low M113 pin S1 output is inverted high and applied to the G847 module, applying a +38V run signal to the forward motor. This action causes the tape to move forward. Simultaneously, pin N2 of the G847 module goes low, applying a +18V drag signal to the reverse motor, thus maintaining the proper tape tension while the tape is in motion.

When the internal up-to-speed delay times out, a controller circuit compares the frequency of the incoming pulses from the tape timing channel to a one-shot output in the controller. Once the two frequencies match, the tape has reached a sufficient speed for reliable data transfer and the controller then compares the first incoming block number from the tape mark channel to the desired block number specified by the command. If the incoming block number is smaller, forward tape motion continues until the desired block number is reached. At this point, read or write data is transferred (Paragraphs 3.4.4 and 3.4.5). If the incoming block number is larger, tape motion must be reversed (turned around) to reach the desired block number. If this is the case, the controller triggers an internal turnaround delay that inhibits further data reception and complements the CON FWD REM and CON REV REM interface lines. This action initiates reverse tape motion in a similar manner as the forward tape motion just described.

After the internal turnaround delay times out, the block numbers are again compared, as previously described, until the desired block number is detected. When this occurs, the tape is again turned around (CON FWD REM and CON REV REM complemented) and once sufficient tape operating speed is acquired, read or write data is transferred (Paragraphs 3.4.4 and 3.4.5).

3.4.4 Write Operation

The DECTape system of recording is unique in that regardless of whether data is being written on or read from the data channels, the timing and mark track amplifiers are always reading the information contained in those two channels.

Once the tape has been properly positioned (Paragraph 3.4.3) and a write operation initiated, the following events occur. The alternating positive and negative flux reversals prerecorded in the timing track (TT) produce a nearly sinusoidal output (Figure 3-5A) at the terminals of the corresponding read coil. The read amplifiers in the controller detect the zero-crossings of this waveform. Zero-crossings in which the signal changes from a negative to a positive level generate a train of TP0 timing pulses. Positive-to-negative transitions generate a separate train of TP1 timing pulses. Physically, these pulses are generated when the timing track read/write coils are positioned between two adjacent flux reversals.

When data bits are being written, each TP0 pulse causes three data bits to be loaded into the data buffers in the controller. The following TP1 pulse then automatically complements all three buffers. Each buffer is in direct control of the write current flowing through the corresponding read/write coil. Thus, depending on the previous state of a given data buffer, the TP0 pulse may or may not cause the data buffer to change state and write a flux reversal on the tape. The TP1 pulse, however, will always cause the buffer to change state and write a flux reversal.

The TU56 magnetic head has been designed in such a way that flux reversals in the magnetic circuits do not occur instantaneously, but lag the reversal of the write currents by 6 to 10 microseconds. This delay is necessitated by the fact that each flux reversal is recorded on tape at a point which is displaced from the center of the write coil gap (Figure 3-5B). The magnitude of this displacement is about 75 percent of the write coil gap width, and the direction of the displacement is the same as the direction of tape motion. As a result of this delay, the flux reversals in the data tracks are positioned between the flux reversals in the timing track. Figure 3-5C illustrates a tape in which the pattern 0077₈ has been written.

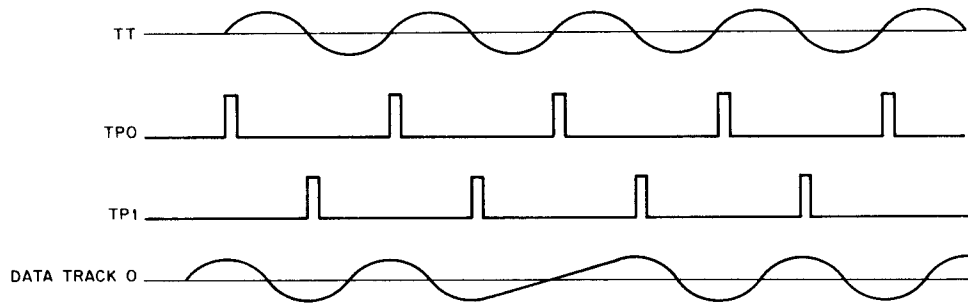

A. Read/Write Waveforms

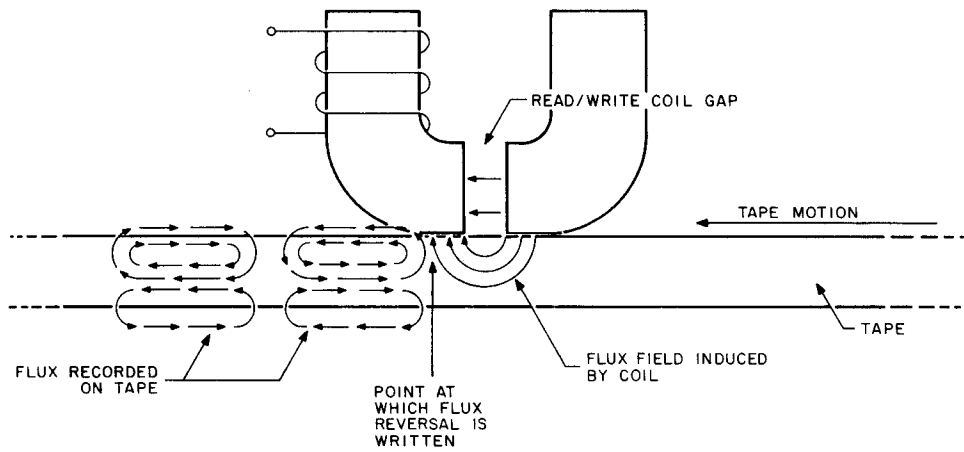

B. Head Flux Recording Location

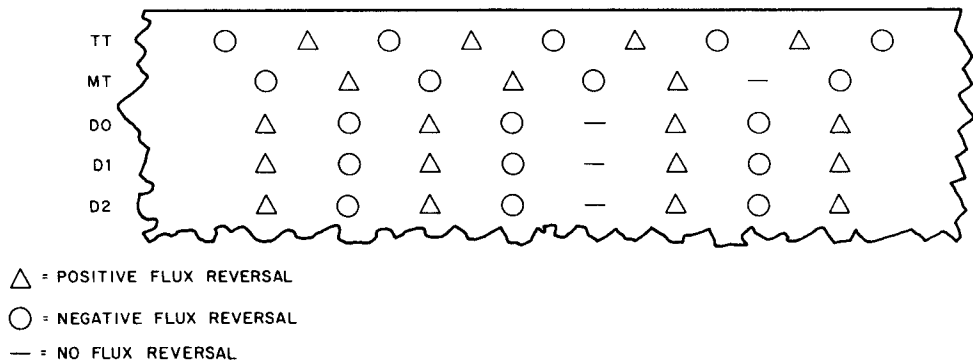

CP-0289

C. Recorded Tape

Figure 3-5 Read/Write Technique

3.4.5 Read Operation

When the section of tape shown in Figure 3-5C is read, the relative positions of the timing and data track flux reversals ensure that the two signals will be read back 90 degrees out of phase. Therefore, if the tape is read while moving in the same direction as it was written, (i.e., the tape was written, rewound over the head, and read), the TP1 pulses will occur close to maxima of the signals from the data tracks.

In order to read the tape, the signals from the data amplifiers are fed to the inputs of the data buffer, and loaded into the buffer when TP1 occurs.

Figure 3-5A illustrates the timing track, TP0, TP1, and data track 0 signals which are generated when the section of tape shown in Figure 3-5C is read while moving in the same direction as it was written. Note that each TP1 pulse occurs at a maximum of the data track signal, and that the polarity of the data track signal at that time defines the value of the bit that was recorded there.

3.5 MODULE DESCRIPTION

Circuit information for the FLIP CHIP modules used in the TU56 DECTape Transport is cataloged in the DEC *Digital Logic Handbook*, C-105. Schematics of these and noncataloged modules are contained in Appendix A. The following paragraphs describe only the noncataloged modules.

3.5.1 G847 Dual Motor Voltage Control

The G847 Dual Motor Voltage Control module (Drawing B-CS-G847-0-1) selects the voltage level that is applied to the tape reel motors. This module contains two 3-stage circuits for control of the two reel motors.

When the run signal is high, Q1 is biased on. Q2 and Q3 are then, in turn, biased on. With Q3 conducting, a high output voltage (approximately +38V) appears at Eout 1. Diode D4 is then reverse biased following the higher output voltage.

Diodes D2 and D9 ensure that the potentials at the base of Q3 and the collector of Q2 do not exceed their design ratings.

When the run signal is low, Q1, Q2, and Q3 are off and D4 conducts; thus, the lower voltage (approximately +18V) appears at Eout 1. Eout 1 is at +38V during run and brake time and at +18V when drag is required on a particular motor. Eout 1 is also at +18V when the REMOTE/OFF/LOCAL switch (SW2) is in the OFF position.

3.5.2 G848 Motor Control Module

The G848 Motor Control module (Drawing C-CS-G848-0-1) is a transistorized bridge circuit designed to operate an ac tape reel motor from a dc source. The operational ac is obtained from an external 40-Hz clock oscillator, whose OSC0 and OSC1 outputs are 180 degrees out of phase with each other.

The bridge circuit controlling the ac tape motor consists of two PNP transistors (Q5 and Q8) and two NPN transistors (Q6 and Q7). The OFF signal can remove power from the motor for an indefinite period.

Transistor turn-on, RC time delay networks (R15 and C4; R24 and C3; R23 and C2; and R3 and C1) prevent two opposing arms in the bridge network from being biased on at the same time. The time delay from turn-off to turn-on is approximately 1 millisecond.

When the OSC1 input is high, Q11 is biased on, and C2 discharges through the low impedance path of the transistor to ground. When C2 discharges, Q10 turns off. When C4 has sufficiently discharged through D12, R15, and Q11, Q9 is turned on and provides a path from the motor power supply to the base of Q7, turning Q7 on.

When the OSC1 input is high, the OSC0 input is low, biasing Q2 off. C1 charges through R3, which in turn causes Q3 to be turned on. Once Q3 is biased on, it turns Q5 on. Diode D8 is then reverse biased, Q4 is biased off, and C3 charges through R25. A current path now exists from the motor power supply, through Q5, through the motor windings, and through Q7 to ground.

The opposite operational characteristics occur when OSC1 input goes low and OSC0 goes high. For this change of state, Q11, Q9, Q7, Q5, and Q3 are now reverse biased, and Q2, Q4, Q6, Q8, and Q10 are forward biased. The two halves of the bridge network oscillate at the 40-Hz clock rate, generating ac current through the motor winding and inducing motor motion.

3.5.3 G859 Clock Regulator Module

The G859 Clock Regulator module (Drawing B-CS-G859-0-1) contains a divide-by-two flip-flop (Q6 and Q7), an 80-Hz oscillator (Q2 and Q3), and a voltage regulator (Q5). The 80-Hz oscillator output is fed through capacitors C3 and C4 to the flip-flop. The resulting 40-Hz square wave output is then connected through two emitter followers (Q1 and Q4) to the G848 Motor Control module.

NOTE

During tape motion, the high harmonic content of the 40-Hz square wave that supplies the tape reel motors produces small, cyclic variations in the power output of the motors. These variations may cause an audible hum which varies in intensity as the reel being driven by a particular motor fills with tape. Such behavior is normal, and has no effect on the performance of the transport.

When +10V is connected to pin A2 of this module, the +5V regulator circuit reduces this input voltage to the +5V level required for logic operation. If +5V is available from an external power supply, the regulator circuit is bypassed.

3.5.4 G888 Manchester Reader/Writer Module

The G888 module (Drawing B-CS-G888-0-1) consists of two portions. The upper read portion of the schematic contains the following:

- a. a linear amplifier (E1) with a gain of 100
- b. a zero-crossing detector (E2)
- c. a limiter (Q1)

During a read operation, the 10 to 12 mV read signals from the read head are applied to pins D and E of linear amplifier E1. The approximately 1V amplified output (test pin H2) is then transmitted to zero-crossing detector E2 pin 2. The square wave E2 output is clamped, by limiter Q1, to the standard DEC logic levels and applied to output gate E3. The signal at output pins U and V is then transmitted via the interface lines to the controller read/write buffer.

The lower write portion of the schematic contains a push-pull amplifier (Q3 and Q5). During a write operation, write data from the controller is ANDed with the T/M ENAB signal at input gate E3 pins 9, 10, 12, and 13. Either output pin J or K, depending upon the polarity of the input signal, drives current to the read/write heads. The applicable G888 module specifications are as follows:

Write Amplifier

Inputs: Standard TTL voltage.
Load at 0V is 1 unit.
R2 should be tied to +3V when not used.

Outputs: Can drive 100 mA in either direction.
Pins L2 and M2 are the outputs of the 7400 TTL gates.
Pins J2 and K2 are the outputs that drive the tape unit write head.

Read Amplifier

Inputs: Can detect an input voltage as low as 500 μ V.

Outputs: Pins U and V are standard TTL voltages.

Fan Out: Pin U2 = 9 unit loads
Pin V2 = 10 unit loads

Test Point: Pin H2 is a test point for the first stage output.

Power Dissipation 50 mW at +5V
250 mW at -15V



CHAPTER 4

MAINTENANCE

4.1 RECOMMENDED TOOLS AND TEST EQUIPMENT

Servicing the TU56 DECtape Transport requires the equipment listed in Table 4-1 and standard hand tools, cleaners, test cables, probes, etc.

Table 4-1
Recommended Maintenance Equipment

Equipment	Manufacturer	Model
Multimeter	Triplet or Simpson	630-NA or 260
Oscilloscope	Tektronix	Series 540, 580, 543 or 544
FLIP CHIP module extender	DEC	W982
Reel Hub Alignment Gauge	DEC	74-08010
Phillips-head screwdrivers		All four standard sizes
Allen wrench set		No. 667
Allen wrench with screwdriver handle		All standard sizes
G500 Skew Test Module	DEC	

4.2 PREVENTIVE MAINTENANCE

When the tape transport is operated on a one shift basis in a normal office environment, perform the following weekly and monthly preventive maintenance (PM) procedures. An excessively dirty environment or heavy transport usage may require more frequent performance of the weekly PM procedure. Since dust and oxide particles contribute significantly to read errors, inspect and clean the tape handling surfaces as often as necessary. Use only the head cleaning solvent supplied in the DEC head cleaning kit (Potter Cleaning Kit A425484B). During the cleaning process, do not allow the solvents to come in contact with the tape or painted surfaces and ensure that all cleaned surfaces are completely dry before loading a tape.

4.2.1 Weekly PM Procedure

1. Unload all tapes from the transport.
2. Use a dry, lint-free cloth to remove all lint, dust, and loose oxide from the front mounting panel. Do not use head cleaning solvent on any painted surfaces.
3. Moisten one of the swabs with head cleaning solvent and clean the oxide from the edges of the tape guides and abutting surfaces. Once a swab has contacted a dirty surface, do not remoisten the swab in such a way as to contaminate the cleaning solvent in the container.

(continued on next page)

4. If necessary, use a pointed wooden dowel that has been soaked in cleaning solvent to remove very old, hard oxide deposits from the edges of the tape guides.
5. Clean the tape guide path and the top of the read/write head with a clean, lint-free cloth moistened with head cleaning solvent.
6. Using a dry, lint-free cloth, wipe the excess cleaning solvent from the read/write head and tape guides.
7. Allow at least 60 seconds for the remaining solvent to evaporate, then reload the tapes.
8. Check for proper operation of the reel motors and electronic brakes by momentarily pushing the Forward (→) and Reverse (←) tape motion switches and observing that the tape moves in the corresponding direction. If the tape does not stop smoothly, adjust the electronic brake (Paragraph 4.3.2.4).

4.2.2 Monthly PM Procedure

If the tape transport is operated on a standard eight hour shift, perform the following procedure once a month. If the transport daily operation exceeds one shift, perform the following procedure more often. Stagger the monthly checkout for individual transports evenly throughout each month.

1. Clean the exterior and interior of the cabinet with a vacuum cleaner and clean cloths moistened, if necessary, in a nonflammable solvent. **DO NOT USE SOLVENTS THAT WILL REMOVE PAINT.**
2. Clean the air filters at the top or bottom of the equipment rack as described in the preventive maintenance section of the appropriate controller maintenance manual.
3. Clean the most frequently used tapes by placing a clean, dry, lint-free cloth over the read/write head, loading the tape on the transport and manually running the tapes over the cloth.
4. Clean the take-up reels, if heavy use has caused oxide build-up around the hub.
5. Inspect the over-all condition of the transport.
6. Inspect the cable and logic modules to ensure that the modules are securely seated in the logic mounting block.
7. Exercise both the transport and the associated controller in all possible modes and directions. Applicable programs for these operations are listed in the appropriate controller maintenance manual. Log all errors to provide a malfunction history as an aid in troubleshooting.
8. Interchange tapes among all transports and use the maintenance program read routines to ensure that all transports can read tapes generated by other transports. If Step 7 was performed satisfactorily, any malfunctions that occur during this step are probably due to head skew. Measure the head skew (Paragraph 4.3.3.4) and if it is not within specifications, consult a DEC field service engineer. (Transports with misaligned heads must be realigned by a qualified DEC field service engineer.)

4.2.3 Tape Care and Cleaning

To obtain maximum longevity and efficiency from DECTapes, observe the following precautions and practices:

- a. Store the tapes where the temperature and relative humidity do not exceed 40 to 90°F and 20 to 80% humidity.
- b. Since strong magnetic fields can distort or destroy the flux reversals on the tape, protect the tape from exposure to magnets or electrical coils.
- c. Do not allow cleaning fluids to contact the DECTape or painted surfaces.

(continued on next page)

- d. Periodically clean the tapes by placing a clean, dry, lint-free cloth over the read/write head and then running the tape over the cloth.
- e. Do not use adhesive-backed tape to start the DECTape on the take-up reel. In time, this practice accelerates oxide buildup on the hub and results in uneven tape packing on the take-up reel.

4.3 CORRECTIVE MAINTENANCE

4.3.1 Control Panel Lamp Replacement

Before performing this procedure, note the position of all burned-out indicators.

1. Remove power from the transport.
2. Turn the mounting panel side-locking fasteners one-quarter turn to unlock the mounting panel.
3. Carefully lower the mounting panel until the support struts are fully extended (Figure 4-1).
4. Remove the backing plate from the control panel logic module by removing the two Phillips-head screws.
5. Remove the four Phillips-head screws from the control panel logic module and lift the module free from the mounting panel.
6. Unsolder and replace all burned-out indicators.
7. Reassemble the transport and restore power.

4.3.2 Reel Motor

4.3.2.1 Motor Removal

1. Remove power from the transport.
2. Remove the tape reel from the hub.
3. Loosen the two hub Allen screws and slide the hub off the shaft.
4. Turn the mounting panel side-locking fasteners one-quarter turn to unlock the mounting panel.
5. Carefully lower the mounting panel until the support struts are fully extended (Figure 4-1).
6. Unplug the reel motor cable connector by pressing the locking tabs that extend from one of the Mate-N-Lok connectors against the side of the connector body and separating the connector halves.

NOTE

If the reel motor connectors are held to the chassis by a nylon cable holder, remove the top of the holder and free the cable.

7. Remove the four screws securing the reel motor to the mounting panel and lift the motor and friction bushings free from the mounting panel.

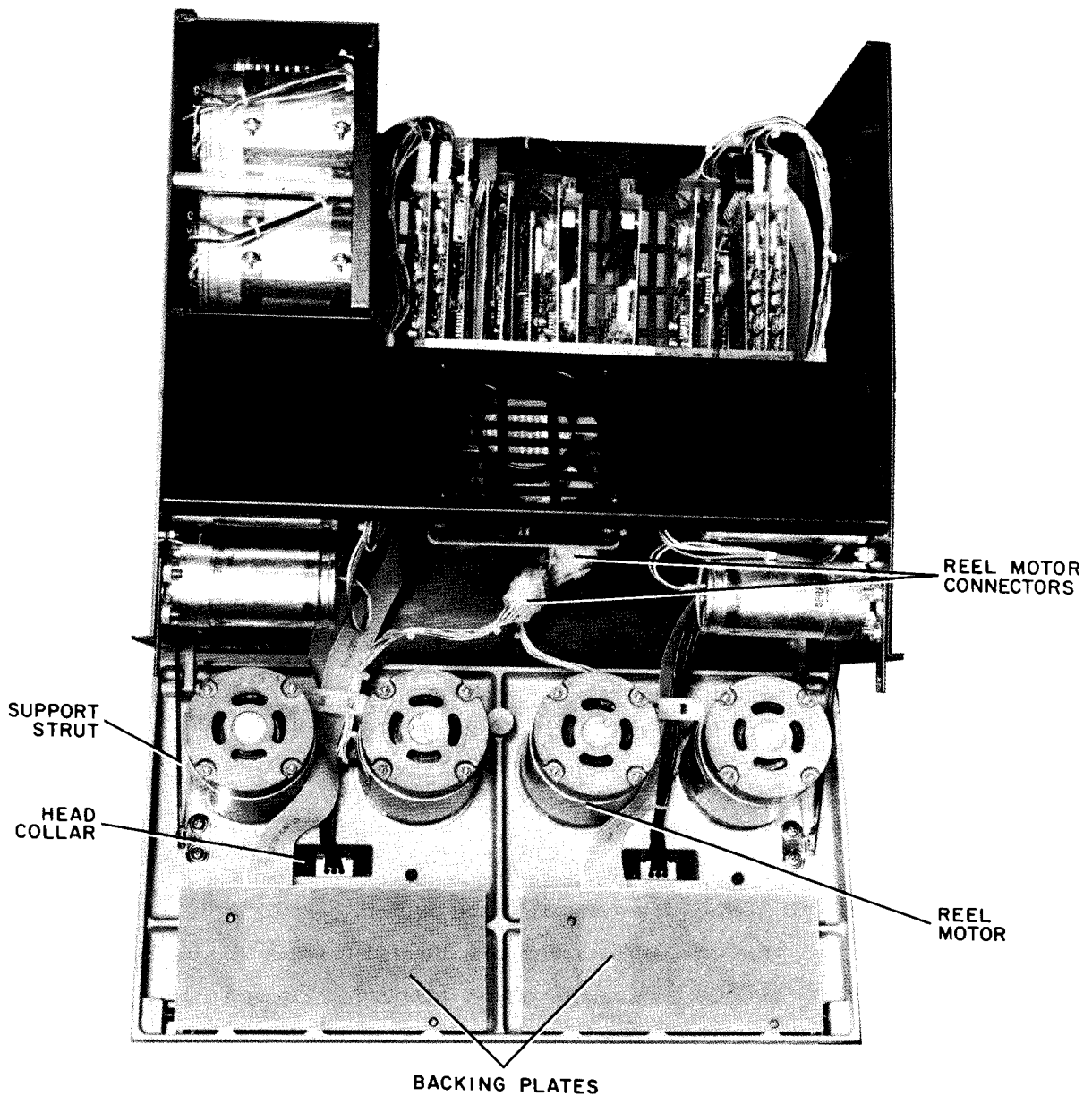

Figure 4-1 Reel Motor Removal

4.3.2.2 Motor Replacement

1. Inspect the friction bushings (P/N 12-09926) and spring (P/N 12-09917), and replace them if necessary.
2. Slide the friction bushings and spring onto the motor shaft, ensuring that the bottom tip of the spring is properly seated between the wings of the C-ring retaining the motor bearing.
3. Insert the reel motor shaft through the opening in the mounting panel (Figure 4-1) and attach the motor with the previously removed hardware.
4. Reconnect the reel motor cable connector.

(continued on next page)

5. Close and lock the mounting panel.
6. Slide the reel hub onto the motor shaft and lightly tighten the hub Allen screws.
7. Perform the hub clearance adjustment (Paragraph 4.3.2.3).
8. Restore the transport power and perform the electronic brake adjustment (Paragraph 4.3.2.4).

4.3.2.3 Reel Hub Clearance Adjustment

1. With the hub gauge (P/N 74-08010), check for .017 inch clearance between the tape reel hub and the flange on the mounting panel (Figure 4-2).
2. If the clearance is incorrect, loosen the Allen screws on the hub and make the necessary adjustment.
3. Retighten the Allen screws.

NOTE

Do not repeatedly loosen or tighten the hub Allen screws. These screws are serrated cup type and may become damaged with excessive use.

4.3.2.4 Reel Motor Electronic Brake Adjustment

1. Load a tape on the transport to be tested.
2. Set the REMOTE/OFF/LOCAL switch to LOCAL.
3. Press and hold the Forward (→) tape motion switch. When the tape is up-to-speed, release the switch and observe that the tape braking action is smooth without overshoot. If tape motion stops, then reverses slightly when the switch is released, the braking time is too long. If the tape coasts, the braking time is too short.
4. If necessary, adjust the top R2 (left transport) or bottom R13 (right transport) potentiometer on the M302 module to obtain the correct brake indications.

4.3.2.5 40-Hz Oscillator Adjustment

If, during remote turnaround operations, consistent mark track or read errors occur, check and adjust the 40-Hz oscillator output in the following manner. Connect an oscilloscope to A03M2 or A03N2 and, if necessary, adjust R2 of the G859 module to obtain a 25-millisecond (40-Hz) square wave.

4.3.3 Read/Write Head

4.3.3.1 Head Removal

1. Remove power from the transport.
2. Remove the tape reels from the hubs.
3. Turn the mounting panel side-locking fasteners one-quarter turn to unlock the mounting panel.
4. Carefully lower the mounting panel until the support struts are fully extended.
5. Disconnect the 22-pin Amphenol head cable connector from the rear of the G851 Relay module (Figure 4-3).
6. Route the Amphenol connector and cables from the rear to the front of the transport.
7. Remove the backing plate from the control panel logic module by removing the two Phillips-head screws (Figure 4-1).

(continued on next page)

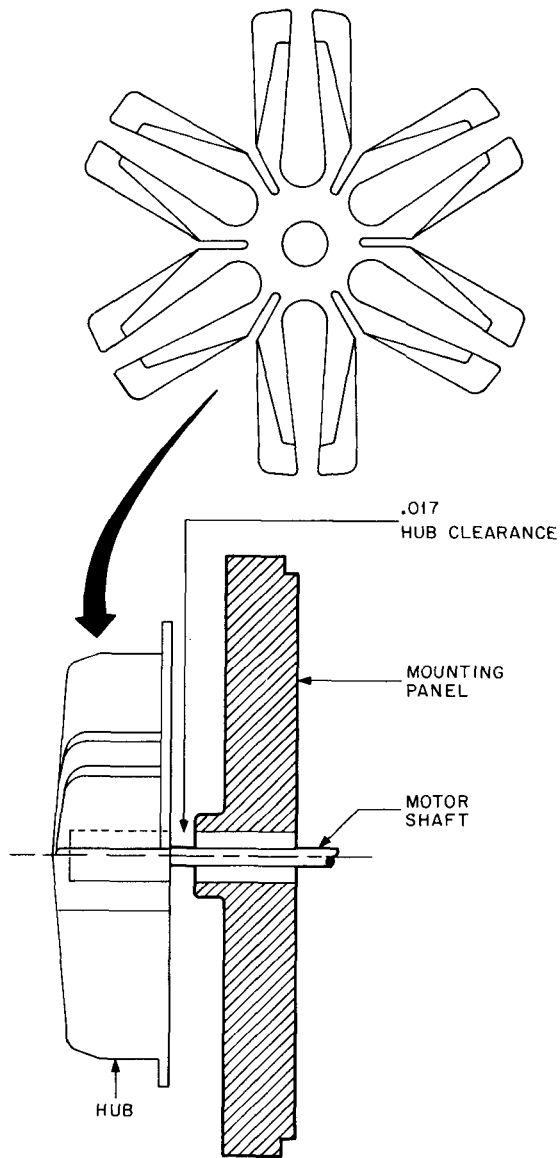

10-0178

Figure 4-2 Reel Hub Clearance

8. Remove the two head screws through the access holes in the control panel logic module.
9. Pull the head away from the mounting panel and remove the head collar by pushing on the back of the collar to break the adhesive bond, then lifting the collar free from the front of the mounting panel.
10. Thread the head cables through the mounting panel. Turn the Amphenol connector sideways and push it through the hole in the mounting panel.

4.3.3.2 Head Replacement

1. Clean the new head mounting face and the mounting area on the transport mounting panel with a clean lint-free cloth moistened with head cleaning solvent.

NOTE

To ensure proper head alignment, the mating area of the head and mounting panel must be entirely free from foreign matter.

2. Turn the 22-pin Amphenol head cable connector sideways and insert it through the hole in the mounting panel front.
3. Install the head on the mounting panel with the previously removed hardware and ensure that the head retaining screws are tightened securely.
4. Route the Amphenol connector and cables from the front to the rear of the transport and plug the connector into the rear of the G851 Relay module (Figure 4-3).
5. Open and close the mounting panel and ensure that the head cables do not chafe or bind.
6. Replace the backing plate on the control panel logic module (Figure 4-1) with the previously removed hardware.
7. Restore power to the transport and perform the head skew check and adjustment (Paragraph 4.3.4.4).
8. Close and lock the mounting panel.
9. Refasten the head collar to the mounting panel and remount the tape reels on the hubs.

4.3.3.3 Head Output Check

To accomplish this check procedure, a single-channel oscilloscope with a high-gain differential preamplifier (Tektronix type D plug-in) capable of handling millivolt signals over a 0- to 60-kHz bandwidth is required. If the heads have been replaced or if consistent read errors indicate that the heads are not operating satisfactorily, clean the heads and perform the following:

1. Load a DECTape on the transport to be tested.
2. Manually run the tape forward until each reel contains approximately one-half of the tape.
3. Disconnect the 22-pin Amphenol head cable connector from the rear of the G851 Relay module (Figure 4-3).
4. Set the oscilloscope controls as follows:
 - sweep time = 10 μ s/div
 - vertical sensitivity = 0.2 mV/div (if X10 probes)
 - trigger = auto internal
5. Attach the scope probes to pins B and C, (Figure 4-3, insert) and the ground clip to pin D of the head connector.
6. Press the Forward (\rightarrow) or Reverse (\leftarrow) tape motion switch and observe the scope display for an approximate 10- to 12-mV peak-to-peak waveform.
7. Repeat Step 5, attaching the scope probes to pins F-H, P-R, U-V, and Y-Z. These signals may not appear sinusoidal (as they do for pins B-C), but the peak-to-peak amplitude should be 10 to 12 mV. If this is not the case, replace the head (Paragraph 4.3.3.1). (Only a qualified DEC field service engineer can replace the heads in the field.)

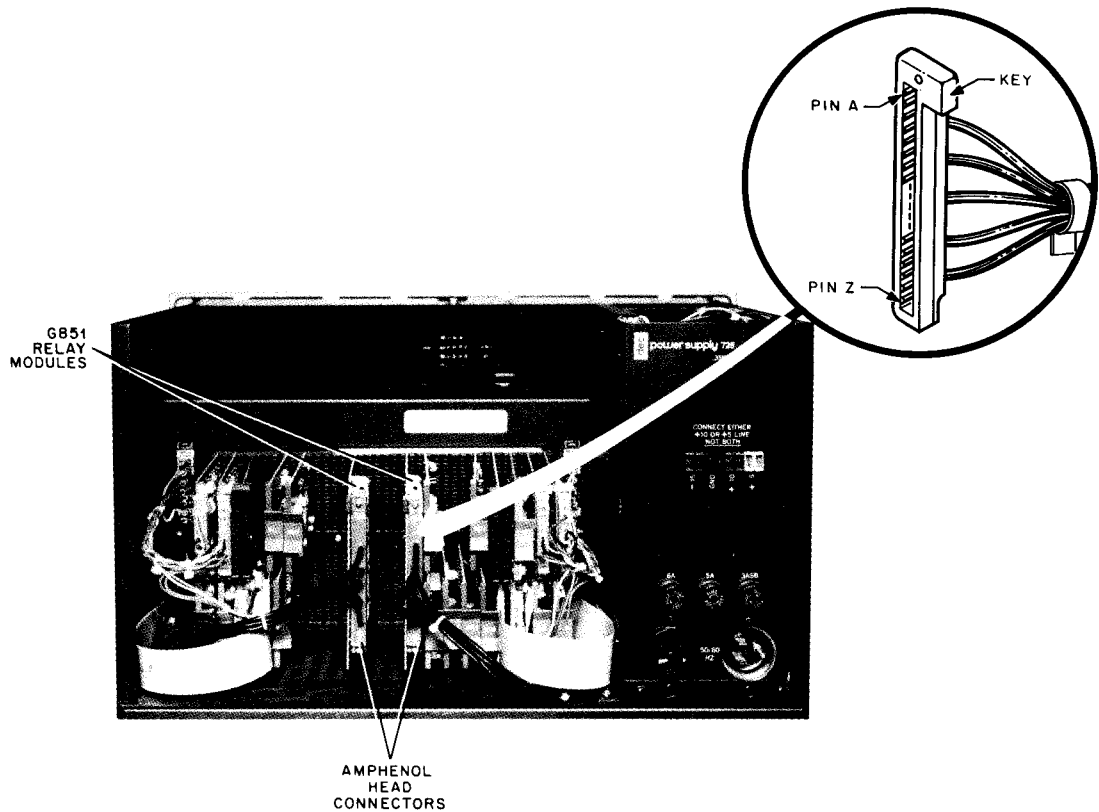

Figure 4-3 Head Connector Location

4.3.3.4 Head Skew Check and Adjustment – Perform the following check whenever an individual transport cannot read tapes that were generated by several other transports without an unusual number of read errors. To accomplish this check procedure, a dual-channel oscilloscope and a special G500 Skew Test module are required.

1. Load a new (unformatted) or blank tape on the transport to be tested.
2. Format the tape using one of the applicable DECTape formatting routines.
3. Remove and interchange the reels so that the full reel is on the right hub.
4. Reverse the tape so that the oxide side is up by threading the tape directly from the bottom of the right full reel onto the top of the left empty reel. Do not thread the tape over the heads.
5. Set the transport to LOCAL and rewind the tape onto the left reel.

NOTE

To maintain tape tension during the rewind operation, apply light hand retarding friction to the right tape reel.

6. Thread the tape, oxide side up, in the normal manner onto the right reel and run the tape forward until each reel contains approximately one-half of the tape.

(continued on next page)

7. Configure the G500 Skew Test module as follows (all switches N.C. = down, N.O. = up):
 - a. S2 – Selects the read/write split coil winding. Use the up position for heads manufactured by Brush or Applied Magnetics; use the down position for Western Magnetic or General Instrument heads. (If this switch is in the wrong position, the read signal at terminal SIG1 of the skew tester will have twice the amplitude of the signal at terminal SIG2.)
 - b. S3 – Selects the input voltage. If the supply voltage at TB1 on the rear of the power supply is +10 Vdc, use the up position; if it is +5 Vdc, use the down position. (Use the down position for M series transports and the up position for R series.)
8. Plug the skew test module into any available logic block slot except slots 03, 04, or 18.
9. Disconnect the 22-pin Amphenol head cable connector from the rear of the G851 Relay module (Figure 4-3) and connect it to the skew tester module, ensuring that the head connector key is positioned relative to pin A as illustrated in Figure 4-4.

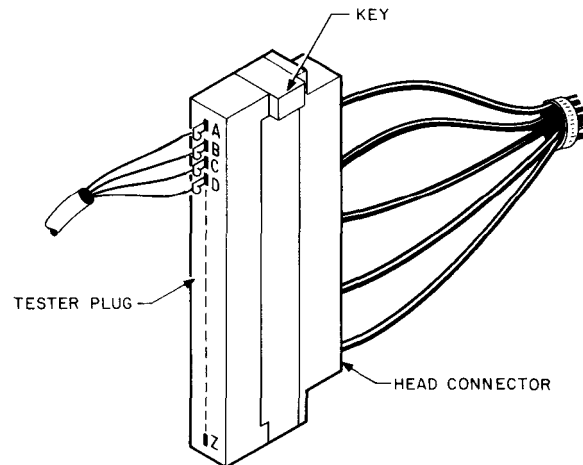

CP - 0288

Figure 4-4 Skew Tester to Head Cable Connection

10. Set the oscilloscope controls as follows:
 - sweep time = 10 μ s/div
 - vertical sensitivity = 1 to 5V/div (depending on signal amplitude), calibrated
 - trigger mode = AC LF reject, internal
 - trigger source = channel A
 - trigger slope = negative
 - preamplifier = add
11. Attach the A channel scope probe to terminal SIG1 of the skew tester and the B channel probe to terminal SIG2.
12. Set the test module switch S1 up and, while running the tape forward over the head, adjust the 10 k Ω potentiometer on the skew tester for the smallest signal.
13. Reset the scope mode switch to ALT and ensure that both signals have approximately the same amplitude and that the zero crossings occur simultaneously.

(continued on next page)

14. Run the tape forward over the head and check for less than a 2-microsecond (one-half the displayed time) skew reading as indicated in Figure 4-5. Ensure that this measurement is taken as near the tape length center as possible and that the scope is triggered from only one channel. For best transport operation, head skew readings should be as close to zero as possible; however, skew readings greater than 2 microseconds indicate that the head must be realigned.
15. If the correct skew reading is not obtained, remove the head (Paragraph 4.3.3.1), thoroughly clean the entire head and the head mounting surface on the transport mounting panel with a clean lint-free cloth moistened with head cleaning solvent.
16. Replace the head and recheck the skew. If the skew reading is still incorrect, align the head as follows. Use extreme care when performing Steps a through d. If care is not taken the heads may become so badly misaligned that it is impossible to distinguish a head with zero skew from one with a skew equal to the interbit distance of the timing track.
 - a. Move the tape forward, oxide side up, over the head and determine whether SIG1 leads or lags SIG2.
 - b. If SIG1 occurs before (leads) SIG2, remove the head and add 0.5 mil (1 inch long by 0.1 inch wide) shims between the left side of the head and the mounting panel. If SIG1 occurs after (lags) SIG2, add the 0.5 mil shims to the right side of the head.

NOTE

It is a general practice to use 3M reflective tape strips as head shims. Always insert the shim close to the edge of the head. Never use more than three shims per side. If more than three shims are required, the shims are being placed on the wrong side of the head or the transport has other malfunctions.

- c. Repeat Steps 1 through 15 to recheck the skew reading after shimming.
- d. Using one of the DEC exerciser routines, read a known good tape that was generated by another transport. If the head skew is less than 2 microseconds after shimming and the transport is able to read a known good tape without errors, the head has been adjusted correctly. (After head alignment, some of the customers old tapes may become unreadable.)

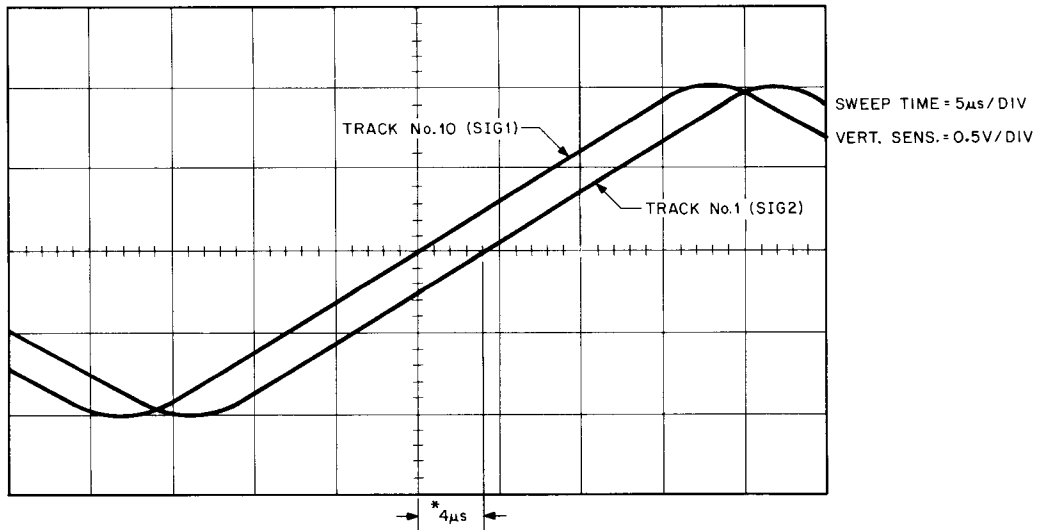

* Zero crossing time equals twice the skew time.
Actual skew = 2 μ s. For best transport operation, head skew should be as close to zero as possible.

CP-0286

Figure 4-5 Head Skew Waveform

4.3.3.5 Write Enable Circuit Check

1. Set the WRITE ENABLE/WRITE LOCK switch to WRITE ENABLE and ensure that the WRITE indicator lights.
2. Check for a ground signal at A06 pin S1 (left transport) or A07 pin S1 (right transport) when the transport is selected.
3. Set the WRITE ENABLE/WRITE LOCK switch to WRITE LOCK and ensure that the WRITE indicator goes off.
4. Check for a -3V signal at A06 pin S1 or A07 pin S1.

4.4 TROUBLESHOOTING

Tables 4-2 (Reel Motor Malfunctions), 4-3 (Control Panel Malfunctions), 4-4 (Logical Malfunctions), and Figure 4-6 list trouble indications and corrective check areas for specific portions of the transport. These tables are intended to be used as a guide during trouble analysis and by no means do they cover all possible malfunctions of the designated areas. When a transport malfunction occurs, perform the initial checks (Paragraph 4.4.1) before proceeding to the tables.

4.4.1 Initial Checks

1. Measure the ac line voltage to ensure that it is the correct value as indicated on the H725 Power Supply label (Drawing C-CS-725-0-1).
2. Measure all the dc voltages at TB1 on the rear of the H725 Power Supply. Ensure that either +10 or +5 Vdc, but not both, is connected to the correct TB1 terminal.
3. Ensure that the connections between the transport and the power supply are tight.
4. Ensure that all logic modules are securely seated in the logic block.
5. Ensure that the reel motor cable connectors (Figure 4-2) are tight.

Table 4-2
Reel Motor Malfunctions

Trouble Indications	Malfunction	Check
Motors do not run in LOCAL or REMOTE.	No high or low motor drive voltage.	3A SB fuse.
Motors turn freely by hand.	Oscillator not operating.	A03 (G859) module.
No drag on motors in LOCAL or REMOTE Hold.	No low motor drive voltage.	5A fuse.
Motors have drag but do not move tape in Fwd or Rev LOCAL.	No high motor drive voltage.	6A fuse.
Motors do not run in LOCAL or REMOTE. Motors do not turn freely by hand.	Oscillator locked.	A03 (G859) module.

(continued on next page)

Table 4-2 (Cont)
Reel Motor Malfunctions

Trouble Indications	Malfunction	Check
Tape moves in one direction in Hold. Tape moves in either Fwd or Rev LOCAL, but not both.	No drive voltage to one motor.	5A fuse on B03 or B18 (G847) modules.
Tape does not move in Hold, nor Fwd or Rev LOCAL.	Motor control module not receiving high drive voltage.	Output of B03 or B18 (G847) modules.
Tape moves but speed, acceleration, or smoothness is abnormal.	Motor not receiving proper wave-shape.	Output of AB01, AB02, AB19, AB20 (G848) modules.

Table 4-3
Control Panel Malfunctions

Trouble Indications	Malfunction	Check
WRITE indicator does not light in WRITE ENABLE.	No -15V at indicator module. Lamp burned out.	B04 or B17 (M922) modules.
Both transport REMOTE SELECT indicators remain lit in any position of the REMOTE/LOCAL switch.	No +5V to indicator module.	Output of A03 (G859) module and +5V terminal at rear of power supply.
Address Select switch does not select in one or more positions.	Select code not being received.	For -3V signal at faulty switch position or erroneous controller output.
REMOTE/LOCAL and Fwd/Hold/Rev switches have no affect. Motors run at all times.	No +5V at indicator module.	B04 or B17 (M922) modules for +5V.

Table 4-4
Logical Malfunctions

Trouble Indications	Malfunction	Check
Tape does not move in either direction.	No MO1 signal.	B07 or A16 (M117) modules.
Tape moves in only one direction.	No DIR1 or DIR0 signal.	B05 or B16 (M113) modules.
Tape does not stop in normal time, seems to coast to a stop.	No BRAKE signal. (Brake time is less than 80 ms.)	Reel motor electronic brake (Paragraph 4.3.2.4).
Tape reverses after stopping.	BRAKE signal too long.	Reel motor electronic brake (Paragraph 4.3.2.4).
No remote control.	I/O signal not received.	Level converter (M531, W513, or M941) modules required for interface with controller.
	I/O signal not sent.	Controller output.

(continued on page 4-14)

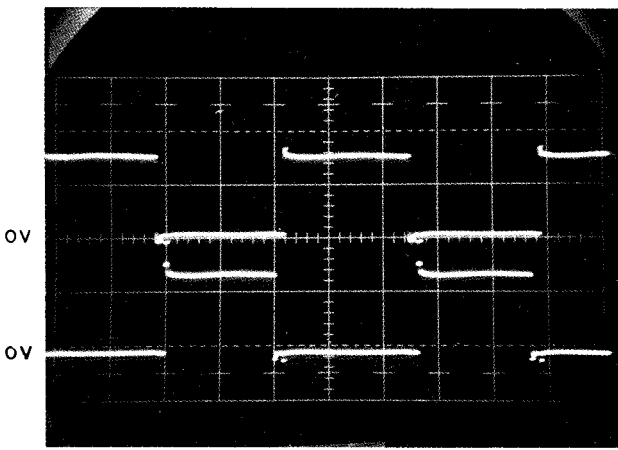

Q5 and Q6 (top), Q7 and Q8 (bottom), Collector Voltage

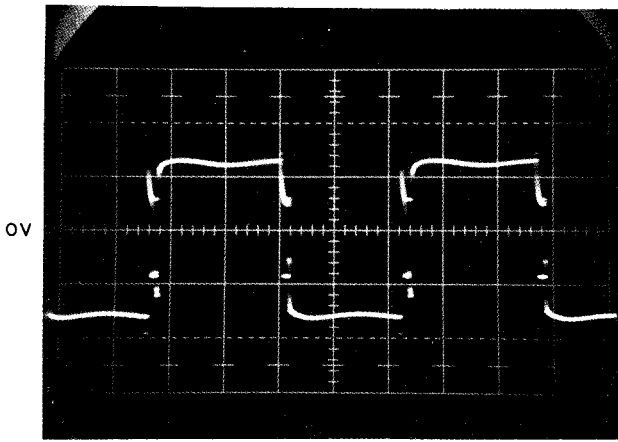

Q7 Emitter to Base Voltage

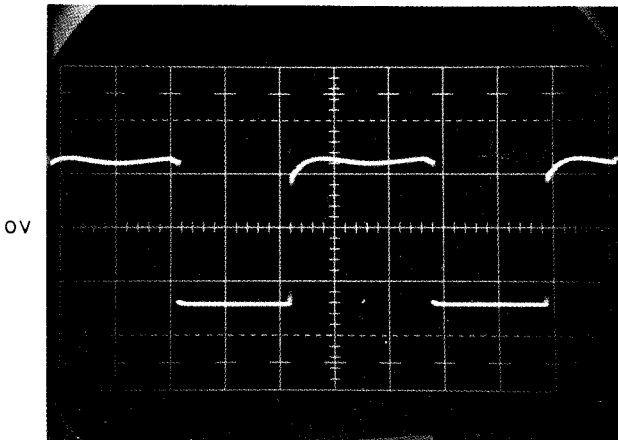

Q8 Emitter to Base Voltage

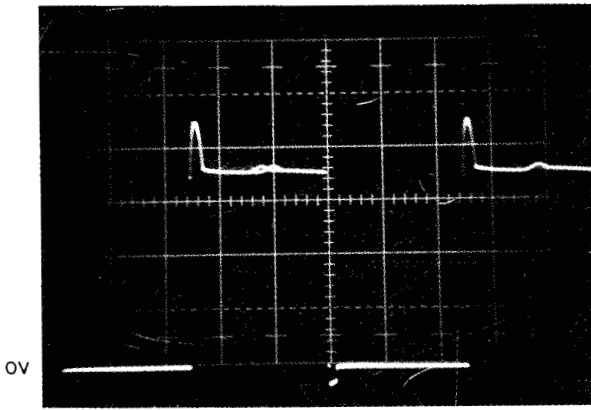

SWEEP TIME = 5ms/DIV
VERT. SENS. = 5V/DIV

Q9 Collector Voltage

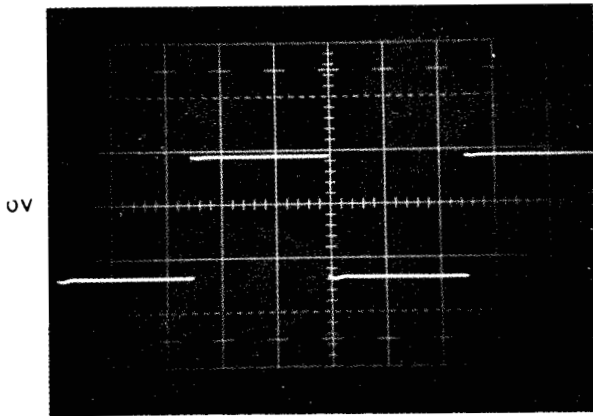

SWEEP TIME = 5ms/DIV
VERT. SENS. = 0.5V/DIV

Q9 Emitter to Base Voltage

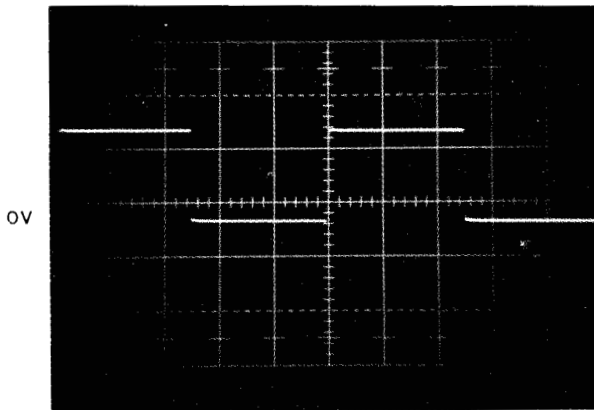

SWEEP TIME = 5ms/DIV
VERT. SENS. = 0.5V/DIV

Q10 Emitter to Base Voltage

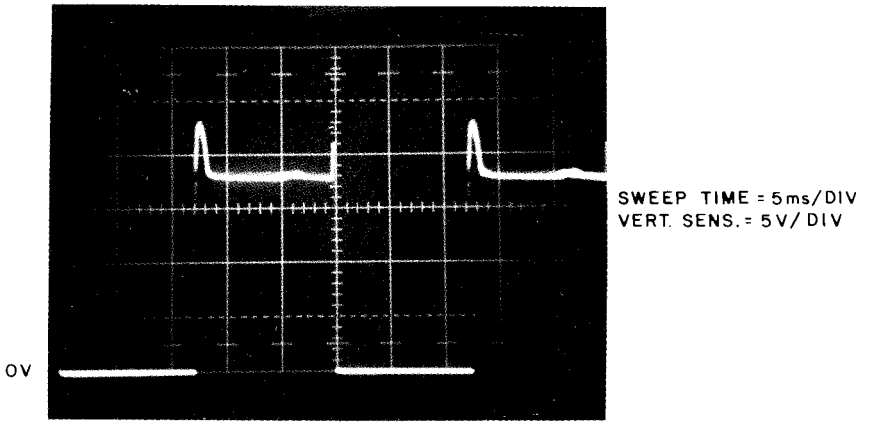

Q10 Collector Voltage

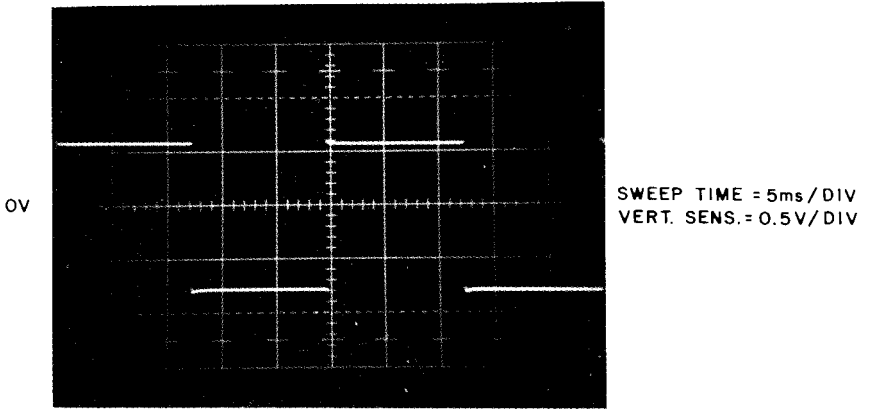

Q11 Emitter to Base Voltage

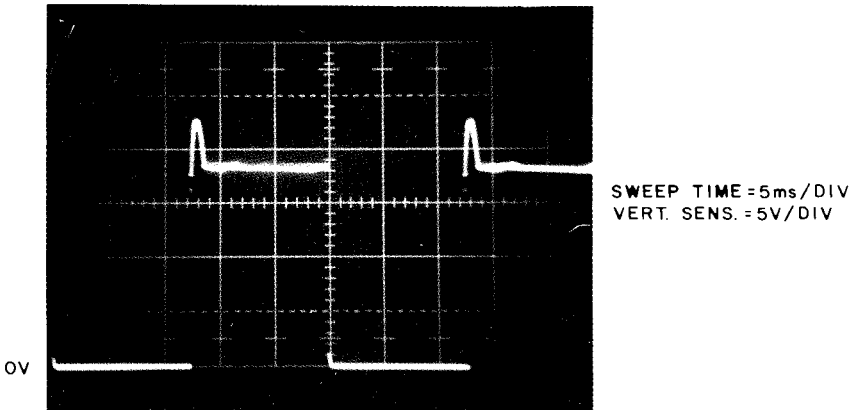

Q11 Collector Voltage

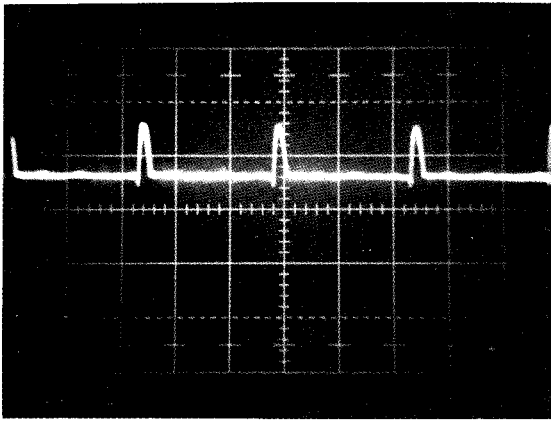

SWEEP TIME = 5ms/DIV
VERT. SENS. = 5V/DIV

Reel Motor Drag Voltage

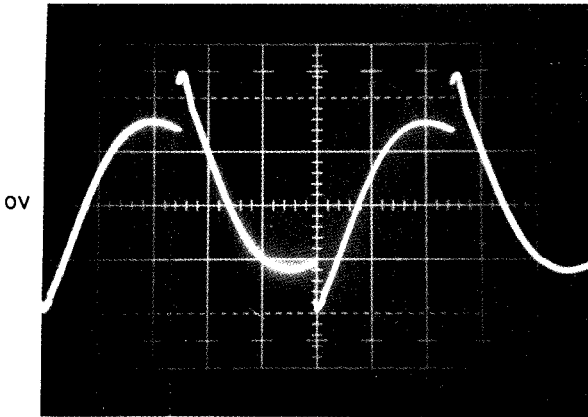

SWEEP TIME = 5ms/DIV
VERT. SENS. = 20V/DIV

Reel Motor Capacitor Voltage

Figure 4-6 G848 Motor Control Module Waveforms

Table 4-4 (Cont)
Logical Malfunctions

Trouble Indications	Malfunction	Check
Select Error	SELECT ECHO incorrect. WRITE ECHO incorrect. Select code error.	A08 or A15 (M040) modules and the 100-Ω resistors on pin side of connectors A06 or A07. Control panel switch configuration. Table 4-3, Control Panel Malfunctions.
Transport does not read or write data.	Data signals not received. Data signals not sent.	AB09 or AB12 (G851) modules. Controller output.
Numerous mark, timing, and/or parity errors.	Data synchronization incorrect.	Head and tape guides for tightness, wear plates for spring tension, condition and cleanliness of tapes and tape handling assemblies. Head skew (Paragraph 4.3.3.4).

4.4.2 Signal Source and Termination Tests

As a maintenance aid during trouble analysis, each TU56 Transport is supplied with a BC02X-3 test cable attached to an M908 Connector module. In order to monitor the signals listed in Tables 4-5, 4-6, and 4-7, connect the BC02X-3 cable to the rear of the M941 Jumper modules in logic panel locations A04 or A18. Test points are now available at the free M908 module end (Figure 4-7) of the cable.

To monitor the transport primary signals at their origin (source test) connect the test cable to the M941 module in location A18 and perform the tests outlined in Table 4-5 (left transport) or Table 4-6 (right transport). When measuring these signals, always connect the oscilloscope ground to point C2 of the M908 module. If the source tests do not indicate a malfunction, connect the test cable to the rear of the M941 module in location A04 and monitor the signals at the power module inputs (termination tests) as outlined in Table 4-7. The table headings are defined as follows:

- Signal = name of signal being tested.
- Test Point = M908 test point.
- Wire Color = color of wire connected to M908 test point.
- Source = logic location where test signal is monitored.
- Switch Setting = position of control panel switches for test.
- Modules and location = logic modules effecting test signal.

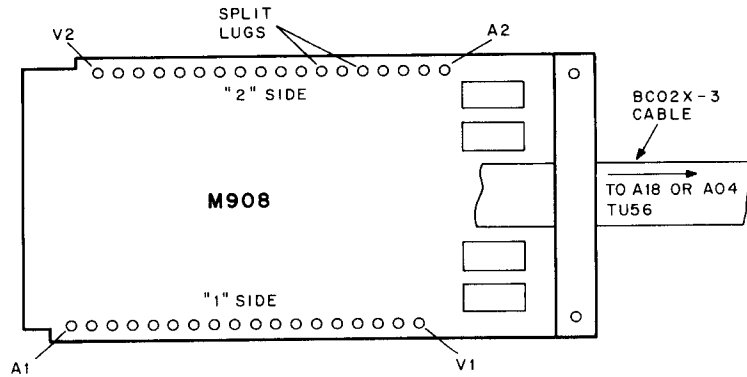

10-0533

Figure 4-7 M908 Module Layout

Table 4-5
Left Transport Source Test Points

Signal	Test Point	Wire Color	Source (TU56)	Switch Setting	Logic Level	Modules and Locations
L MO1	A1	vio	B07-E1	→LOCAL/←LOCAL Hold*/REMOTE	high low	M117-B07 M113-B06
L DIR1	B1	blu	B07-L1	→LOCAL ←LOCAL/REMOTE Hold*	high low no change	M117-B07 M113-B06
L SELECT	C1	grn	B05-N2	without REMOTE selection	low	M113-B05
L FWD LOCAL	D1	yel	B04-M1	→LOCAL ←LOCAL/Hold*/REMOTE	low high	control panel
L REV LOCAL	E1	orn	B04-K1	←LOCAL →LOCAL/Hold*/REMOTE	low high	control panel
L HOLD	F1	red	B04-P1	Hold* →LOCAL/←LOCAL/REMOTE/OFF	low high	control panel
L WRT ENAB	H1	brn	B04-A1	WRITE ENABLE WRITE LOCK	high low	control panel
L REMOTE	J1	blk	B05-S2	REMOTE LOCAL/OFF	high low	M113-B05

*Hold is the center switch position between → and ← .

Table 4-6
Right Transport Source Test Points

Signal	Test Point	Wire Color	Source (TU56)	Switch Setting	Logic Level	Modules and Locations
R MO1	K1	wht	A16-E1	→LOCAL/ ←LOCAL Hold*/REMOTE	high low	M117-A16 M113-B06
R DIR1	L1	gry	A16-P2	→LOCAL ←LOCAL/REMOTE Hold*	high low no change	M113-B06 M117-A16
R SELECT	M1	vio	B16-N2	without REMOTE selection	low	M113-B16
R FWD LOCAL	N1	blu	B17-M1	→LOCAL ←LOCAL/Hold*/REMOTE	low high	control panel
R REV LOCAL	P1	grn	B17-K1	→LOCAL ←LOCAL/Hold*/REMOTE	low high	control panel
R HOLD	R1	yel	B17-P1	Hold* →LOCAL/ ←LOCAL/REMOTE/OFF	low high	control panel
R WRT ENAB	S1	orn	B17-A1	WRITE ENABLE WRITE LOCK	high low	control panel
R REMOTE	V1	brn	B16-S2	REMOTE LOCAL/OFF	high low	M113-B16

*Hold is the center switch position between → and ← .

Table 4-7
Right and Left Transport Termination Test Points

Signal	Test Point	Wire Color	Source (TU56)	Switch Settings	Logic Level	Modules and Locations
+5	A1	vio	A03-A2	NONE	+5 ± 0.5 Vdc	G859-A03
-15	B1	blu	A03-B2	NONE	-15 ± 1.5 Vdc	Power Supply
OSC 1 (left)	C1	grn	B01-S2	NONE	40 Hz square wave	G859 A03
OSC 0 (left)	D1	yel	B01-D2	NONE		
OSC 1 (right)	E1	orn	B20-S2	NONE		
OSC 0 (right)	F1	red	B20-D2	NONE		
L OFF	H1	brn	B01-R2	OFF REMOTE/LOCAL	high low	M113-B05
R OFF	J1	blk	B20-R2	OFF REMOTE/LOCAL	high low	M113-B16
L MO1	K1	wht	B05-P1	→LOCAL/←LOCAL REMOTE/Hold*	high low	

(continued on next page)

Table 4-7 (Cont)

Right and Left Transport Termination Test Points

Signal	Test Point	Wire Color	Source (TU56)	Switch Settings	Logic Level	Modules and Locations
R MOI	L1	gry	B16-P1	←LOCAL/→LOCAL REMOTE/Hold*	high low	
L SELCODE	M1	vio	B05-U2	REMOTE and selected	high	**
R SELCODE	N1	blu	B16-U2	REMOTE and selected	high	**
L RUN FWD	P1	grn	B05-K1	→LOCAL ←LOCAL/REMOTE/Hold Release from ←LOCAL	high low high***	M113-B05 M117-B07
L RUN 2 REV	R1	yel	B05-K2	←LOCAL →LOCAL/REMOTE/Hold Release from →LOCAL	high low high***	M113-B05 M117-B07
R RUN FWD	S1	orn	B16-K1	←LOCAL →LOCAL/REMOTE/Hold Release from →LOCAL	high low high***	M113-B05 M117-B07
R RUN 2 REV	U1	brn	B16-K2	→LOCAL ←LOCAL/REMOTE/Hold Release from ←LOCAL	high low	M113-B05 M117-B07

*Hold is the switch position between → and ←.

**Module depends on controller type.

***High for 80 to 90 ms.

Controller Input Test Points

The following input signals from the controller are also available on this cable.

STOP	D2	yel	A04-D2	Controller GO	*
GO	F2	red	A04-F2	Controller STOP	*
REV REM	J2	blk	A04-J2	Controller REV REM	*
FWD REM	L2	gry	A04-L2	Controller FWD REM	*
ALL HALT	N2	blu	A04-N2	Controller ALL HALT	*
SELCODE	R2	yel	A04-R2	Transport Selected	*

*Voltage level depends on controller type.

4.5 RECOMMENDED SPARE PARTS

One of each of the modules listed in Table 4-8, plus three pica fuses (Part No. 1205747), should be retained at the site as backup spares.

Table 4-8
Recommended Spare Parts

Module	Name
M531	Bus Converter
M040	Solenoid Driver
G851	Relay
M117	6-4 Input NAND Gate
M113	10-2 Input NAND Gate
M302	Dual Delay MV
G848	Motor Control
M908	Connector
W032	Cable Connector
G888 Option*	Manchester Reader/Writer
M922	Cable Connector
M923 Option*	Cable Connector
G847	Dual Motor Voltage Control

*Refer to Paragraph 1.3.

APPENDIX A

REFERENCE DRAWINGS

Title	Drawing No.	Rev	Page
TU56 Assembly	E-UA-TU56-0-0	K	A-3
Transport Logic Diagram	D-BS-TU56-0-TLD	K	A-7
Module Utilization	D-MU-TU56-0-MU	F	A-11
Wired Assy TU56	D-AD-7006321-0-0	E	A-13
Motor Control G848	D-CS-G848-0-1	J	A-15
Dual Motor Voltage Control G847	B-CS-G847-0-1	D	A-17
Relay G851	B-CS-G851-0-1	B	A-17
Clock and Regulator G859	B-CS-G859-0-1	C	A-18
Manchester Reader/Writer G888	B-CS-G888-0-1		A-18
Solenoid Driver M040	B-CS-M040-0-1	E	A-19
One Shot Delay M302	B-CS-M302-0-1	L	A-19
10-2 Input Nand Gates M113	B-CS-M113-0-1	C	A-20
6-4 Input Nand Gates M117	B-CS-M117-0-1	E	A-20
Negative Bus Converter M531	C-CS-M531-0-1	A	A-21
Connector Module M908	B-CS-M908-0-1		A-22
Connector W032	B-CS-W032-0-1		A-22
Level Amplifier W513	B-CS-W513-0-1	E	A-23
Blank Module W990	B-CS-W990-0-1	A	A-23
Power Supply 725	C-CS-M531-0-1	C	A-24



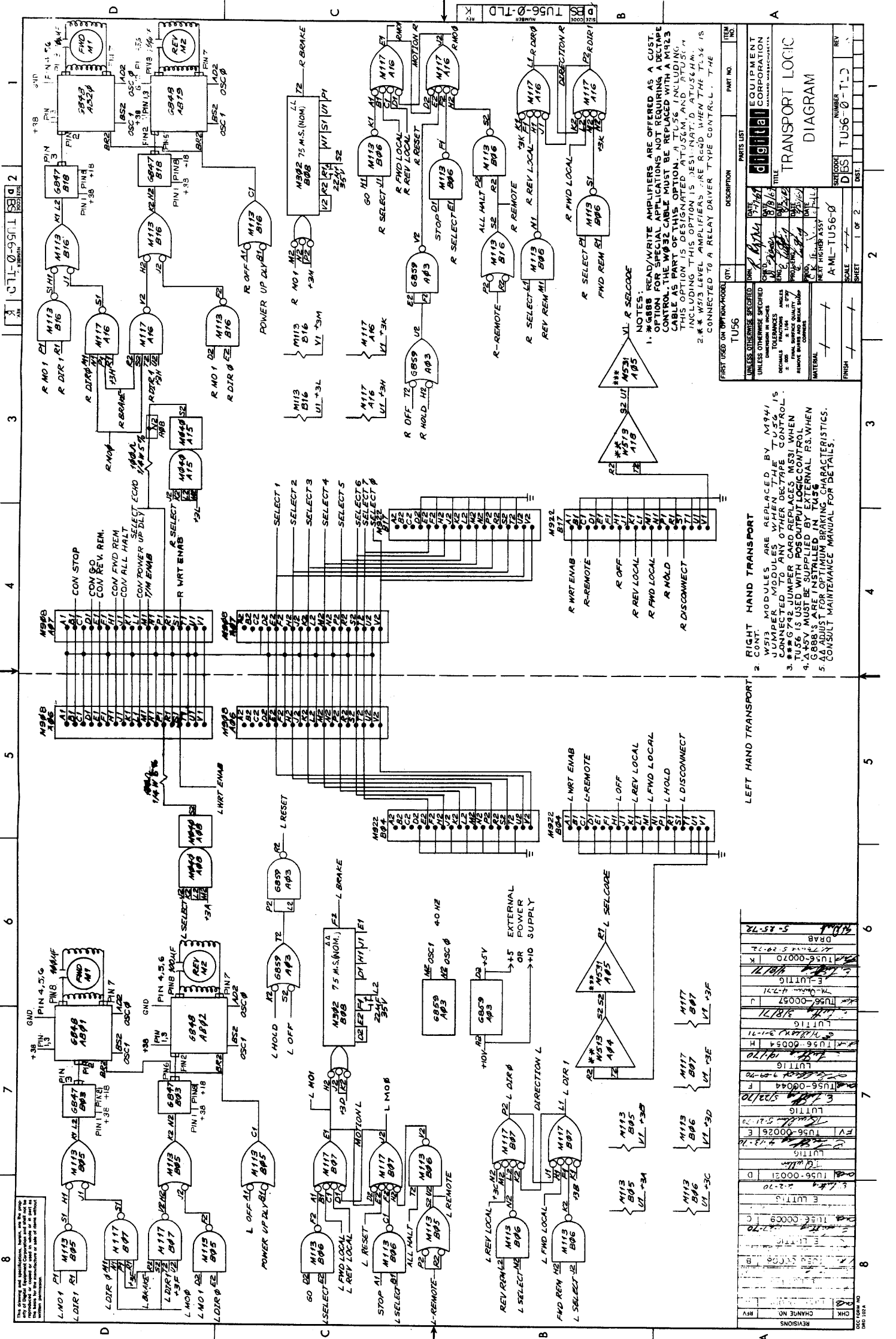

REV	
NUMBER	TU56-0-TLD
SIZE CODE	DES
SCALE	1 OF 2
SHEET	2
FINISH	
MATERIAL	
REMARKS	REWORK HIGH RES ASSY
DATE	
DESIGNED BY	
ENGINEER	
INSPECTED BY	
DATE	
REV	
DESCRIPTION	TU56
QUANTITY	
PARTS LIST	
ITEM NO.	
DESCRIPTION	
QTY.	
REVISIONS	
CHANGED BY	
DATE	
REV	
DESCRIPTION	
QTY.	
REVISIONS	
CHANGED BY	
DATE	

RIGHT HAND TRANSPORT
 2. CONT.
 W513 MODULES ARE REPLACED BY M941 IS JUMPER MODULES WHEN THE TU56 IS CONNECTED TO ANY OTHER DECADE CONTROL. TU56 IS USED WITH POSITIVE LOGIC CONTROL. M945 MUST BE SUPPLIED BY EXTERNAL PS WHEN G888'S ARE INSTALLED IN TU56. ALWAYS CONSULT FOR OPTIMUM BRAKING CHARACTERISTICS. CONSULT MAINTENANCE MANUAL FOR DETAILS.

REV	
DESCRIPTION	
QTY.	
REVISIONS	
CHANGED BY	
DATE	
REV	
DESCRIPTION	
QTY.	
REVISIONS	
CHANGED BY	
DATE	
REV	
DESCRIPTION	
QTY.	
REVISIONS	
CHANGED BY	
DATE	

8	7	6	5	4	3	2	1
23	24	25	26	27	28	29	30
31	32	33	34	35	36	37	38
39	40	41	42	43	44		
45	46	47	48	49	50	51	52

REVISIONS

NO.	DATE	BY	DESCRIPTION
1	02/11/70
2	02/11/70
3	02/11/70
4	02/11/70
5	02/11/70
6	02/11/70
7	02/11/70
8	02/11/70

CHANGELIST

DATE: 02/11/70

BY: ...

DESCRIPTION: ...

IF CONN. TO ANOTHER TU56 USE CABLE #D-UA-BC02X-3-0. IF CONN. TO TU55 USE CABLE #D-IA-7006223-0-0

**** THE M941 JUMPER MODULES ARE REPLACED WITH W513 LEVEL AMPLIFIER MODULES WHEN THE TU56 IS CONNECTED TO A RELAY DRIVER**

***** 6742 JUMPER CARD REPLACES M531 WHEN TU 56 IS USED WITH POSITIVE OUTPUT LOGIC CONTROL**

IF TU56 IS REQ'D USE ALL MODULES & CABLES SHOWN WITH THE EXCEPTION OF NOTES LISTED ABOVE. IF TU56-H IS REQ'D ONLY MODULES & CABLES IND. BY ARROWS ARE USED

23	24	25	26	27	28	29	30	31	32	33	34	35	36	37	38	39	40	41	42	43	44
21	21	21	21	21	21	21	21	21	21	21	21	21	21	21	21	21	21	21	21	21	21
21	21	21	21	21	21	21	21	21	21	21	21	21	21	21	21	21	21	21	21	21	21
21	21	21	21	21	21	21	21	21	21	21	21	21	21	21	21	21	21	21	21	21	21

This drawing and specifications items are the property of Digital Equipment Corporation and shall not be reproduced or transmitted in any form or by any means without the written permission of Digital Equipment Corporation.

0-0-13000L
REV. 1

EXTERNAL COMPONENT LIST NOTES:

1. CONNECTIONS ON ITEMS #1 & #2 TO BE SOLDERED AND LOCATED AT MINIMUM PRACTICAL HEIGHT ABOVE BLACK CONN BLOCK TO BE GROUNDED
2. TO GND LUG AS SHOWN
3. USE YELLOW WIRE (ITEM #3) FOR MACHINE WRAPPED 5 BLJE WIRE (ITEM #4) FOR HAND WRAPPED WIRING (ITEM #4) FOR HAND WRAPPED WIRING
4. JUMPER GROUND BUSSING AS SHOWN 1 PLACE

ITEM NO.	COMP	FROM	TO	POL
13	RESISTOR	AG6S2	AG6P1	+
13	RESISTOR	AG6V2	AG6P1	+
14	CAPACITOR	BA6F1	AG6L2	+
14	CAPACITOR	BA6R1	BA6S2	+

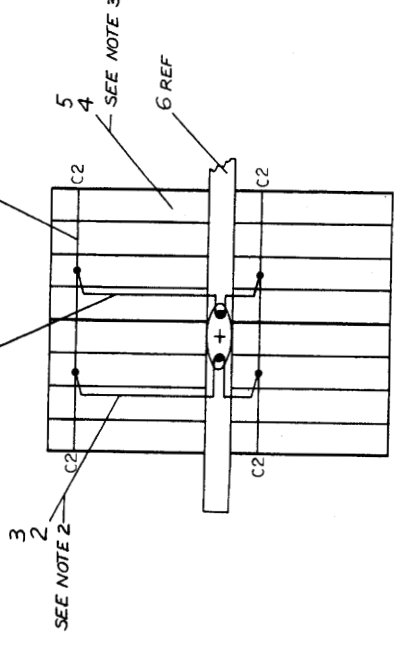
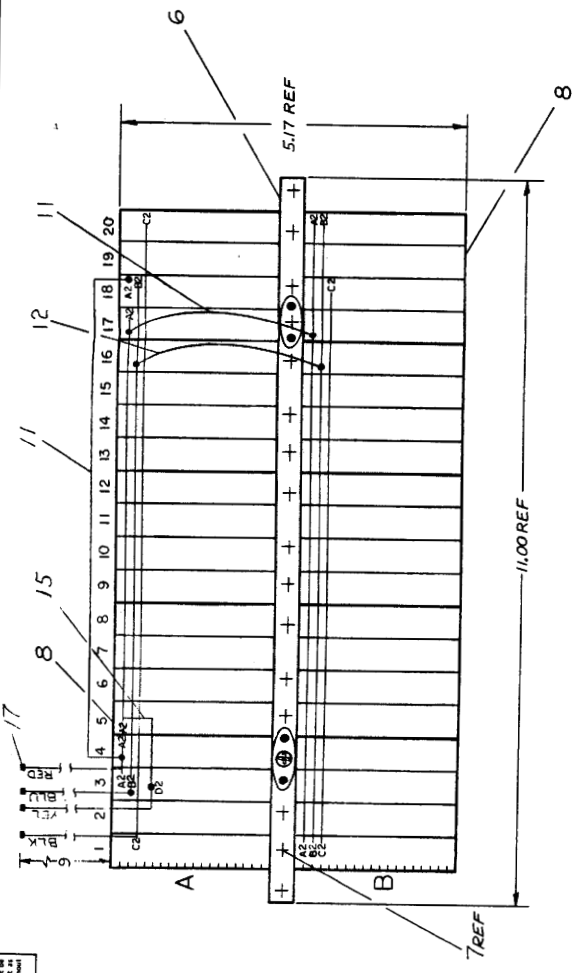

GROUND WIRING DETAIL
SEE NOTE 4

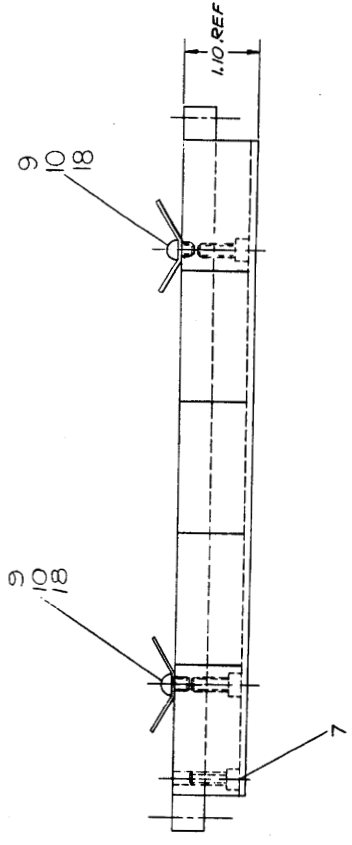

REV	CHANGE NO.	DESCRIPTION
1		E LUTIG
2		E LUTIG
3		E LUTIG
4		E LUTIG
5		E LUTIG
6		E LUTIG
7		E LUTIG
8		E LUTIG
9		E LUTIG
10		E LUTIG
11		E LUTIG
12		E LUTIG
13		E LUTIG
14		E LUTIG
15		E LUTIG
16		E LUTIG
17		E LUTIG
18		E LUTIG
19		E LUTIG
20		E LUTIG

FIRST USED ON OPTION/MODEL	TOLERANCES
TU56	DECIMALS
	XXX = ± .005
	XX = ± .02
	X = ± .1

DO NOT SCALE DRAWING UNLESS OTHERWISE SPECIFIED	UNLESS OTHERWISE SPECIFIED
DIMENSIONS IN INCHES	ANGLES
± .005	± .005
± .01	± .01
± .02	± .02
± .05	± .05
± .1	± .1
± .2	± .2
± .5	± .5
± 1.0	± 1.0
± 2.0	± 2.0
± 5.0	± 5.0
± 10.0	± 10.0
± 20.0	± 20.0
± 50.0	± 50.0
± 100.0	± 100.0
± 200.0	± 200.0
± 500.0	± 500.0
± 1000.0	± 1000.0

DATE	BY	CHKD	APP'D
12/1/70	J. LUTIG	J. LUTIG	J. LUTIG
12/2/70	J. LUTIG	J. LUTIG	J. LUTIG
12/3/70	J. LUTIG	J. LUTIG	J. LUTIG
12/4/70	J. LUTIG	J. LUTIG	J. LUTIG
12/5/70	J. LUTIG	J. LUTIG	J. LUTIG
12/6/70	J. LUTIG	J. LUTIG	J. LUTIG
12/7/70	J. LUTIG	J. LUTIG	J. LUTIG
12/8/70	J. LUTIG	J. LUTIG	J. LUTIG
12/9/70	J. LUTIG	J. LUTIG	J. LUTIG
12/10/70	J. LUTIG	J. LUTIG	J. LUTIG
12/11/70	J. LUTIG	J. LUTIG	J. LUTIG
12/12/70	J. LUTIG	J. LUTIG	J. LUTIG
12/13/70	J. LUTIG	J. LUTIG	J. LUTIG
12/14/70	J. LUTIG	J. LUTIG	J. LUTIG
12/15/70	J. LUTIG	J. LUTIG	J. LUTIG
12/16/70	J. LUTIG	J. LUTIG	J. LUTIG
12/17/70	J. LUTIG	J. LUTIG	J. LUTIG
12/18/70	J. LUTIG	J. LUTIG	J. LUTIG
12/19/70	J. LUTIG	J. LUTIG	J. LUTIG
12/20/70	J. LUTIG	J. LUTIG	J. LUTIG

QTY.	DESCRIPTION	PART NO.	ITEM NO.
1	WIRED ASSY	TU56	1

REV	CHANGE NO.	DESCRIPTION
1		E LUTIG
2		E LUTIG
3		E LUTIG
4		E LUTIG
5		E LUTIG
6		E LUTIG
7		E LUTIG
8		E LUTIG
9		E LUTIG
10		E LUTIG
11		E LUTIG
12		E LUTIG
13		E LUTIG
14		E LUTIG
15		E LUTIG
16		E LUTIG
17		E LUTIG
18		E LUTIG
19		E LUTIG
20		E LUTIG

1-O-8483 SO 6
REV. 1
DATE 11-10-64
BY J. F. [unclear]

THIS SCHEMATIC IS FURNISHED ONLY FOR LIST AND MAINTENANCE PURPOSES. THE INFORMATION CONTAINED HEREIN IS UNCLASSIFIED EXCEPT WHERE SHOWN OTHERWISE. COPYRIGHT © 1971 BY DIGITAL EQUIPMENT CORPORATION

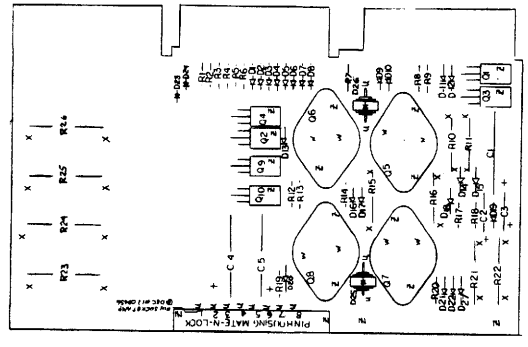
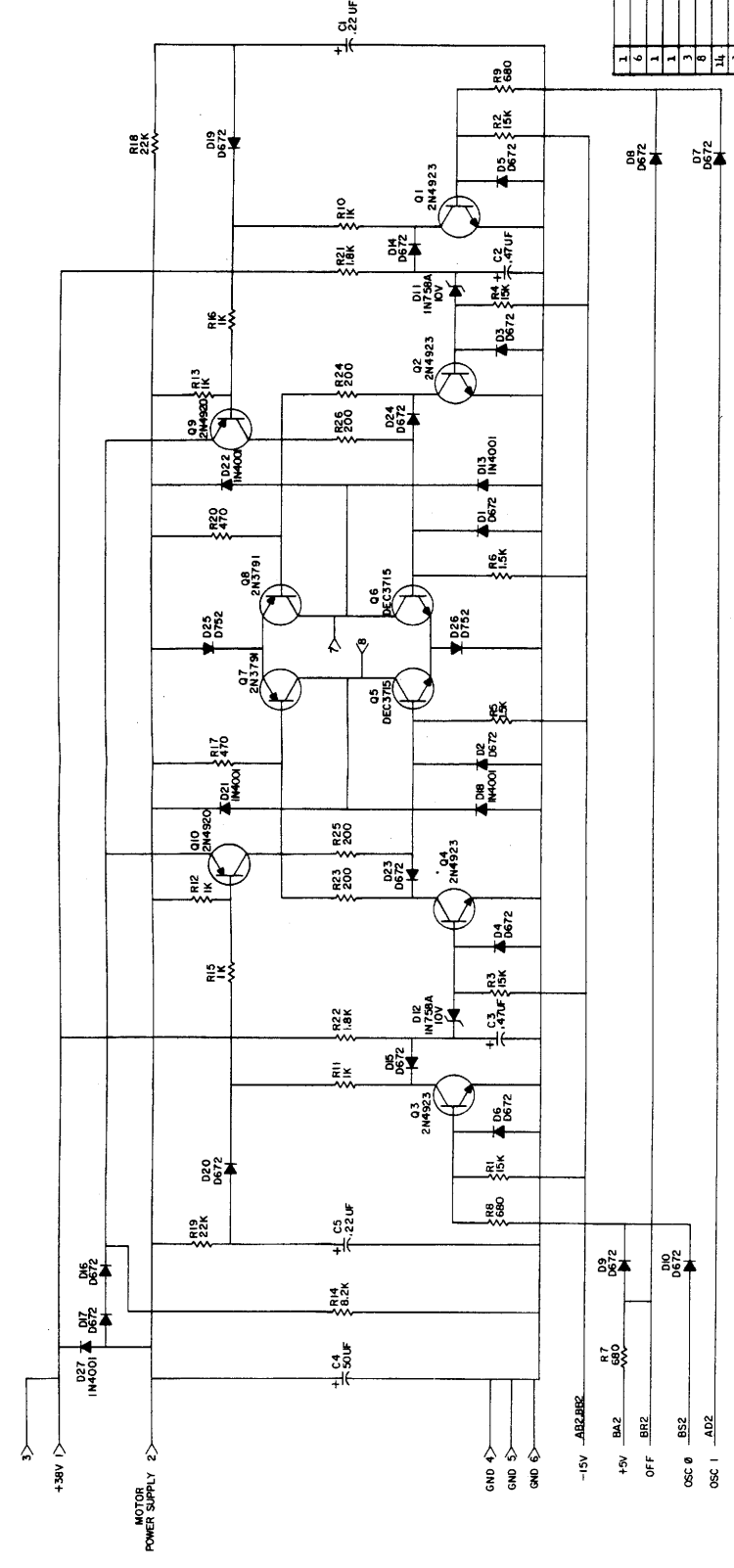

QTY.	REP.	DESIGNATION	DESCRIPTION	PARTS LIST	DATE	BY	CHKD	REV.	REVISIONS
1		PIB	PIB SPACER 1/4 x 1/4 x #6	9067615					
6		L-40	HEX NUT	9066556					
3		NYLON	HEX NUT #4	9067992					
3		NYLON	SCREW 1/4-40 x 1/2	9064022-4					
3		HARDENED	EYEBOLT	9066732					
8		L-40	HEX NUT	9066557					
14		L-40 x 5/16	SCREW	9066010-4					
2		HARDENED, FLIP	CHIEF - GREEN	9068337-01					
2	Q9, 10	TRANSISTOR	2N4920	1509605					
4	Q1, 2, 4, 3	TRANSISTOR	2N4923	1509604					
2	Q7, 8	TRANSISTOR	2N3791	1509581					
2	Q5, 6	TRANSISTOR	DEC3715	1503608					
2	R18, 19	RES.	22K 1/4 W 5%	1309639					
4	R23, 24, 25, 26	RES.	200 5/8 W 5%	1300496					
4	R1, 2, 3, 4	RES.	8.2K 2W 10%	1303179					
1	R11	RES.	1.8K 2W 10%	1304602					
2	R21, 22	RES.	1.5K 1/4 W 5%	1300391					
2	R5, 6	RES.	1.5K 1/4 W 5%	1300391					
4	R10, 11, 15, 16	RES.	1K 1/4 W 5%	1300348					
4	R12, 13	RES.	480 1/4 W 5%	1300355					
2	R7, 9, 9	RES.	480 1/4 W 5%	1300354					
2	R17, 20	RES.	470 1/4 W 5%	1300316					
1		PIB	SCREW	1209456					
1		PIB	SCREW	1209460					
2	D11, 12	DIODE	ZENER 1N758 10V, 1/4W 5%	1160930					
2	D5, 26	DIODE	D75E	1160125					
18	D1, 10, 14, 17, 19, 20, 23, 24	DIODE	D67Z	1110615					
5	D13, 18, 21, 22, 27	DIODE	D67Z	1165275					
2	C1, 5	CAP.	0.22UF 100V 10% NYLAR	1060037					
2	C2, 3	CAP.	0.1UF 35V 10% S.M.T.	1065945					
1	C4	CAP.	50UF 50V 10% 75% S.M.T.	1000800					
1		PCB	CIRCUIT BOARD	5008522					
1		MODULAR	W/O HISTORY	8-111-0818-0-6					
3		ETCH BOARD, MOTOR CONT		E-14-500453-0-0-0					
2		X-Y	COORDINATE HOLE LOCATION	K-C-0-818-0-4					
1		REP.	DESIGNATION	DESC. PART NO.					

DATE	BY	CHKD	REV.	REVISIONS
11-10-64	J. F. [unclear]		1	INITIALS
11-10-64	J. F. [unclear]		2	INITIALS
11-10-64	J. F. [unclear]		3	INITIALS
11-10-64	J. F. [unclear]		4	INITIALS
11-10-64	J. F. [unclear]		5	INITIALS
11-10-64	J. F. [unclear]		6	INITIALS
11-10-64	J. F. [unclear]		7	INITIALS
11-10-64	J. F. [unclear]		8	INITIALS
11-10-64	J. F. [unclear]		9	INITIALS
11-10-64	J. F. [unclear]		10	INITIALS
11-10-64	J. F. [unclear]		11	INITIALS
11-10-64	J. F. [unclear]		12	INITIALS
11-10-64	J. F. [unclear]		13	INITIALS
11-10-64	J. F. [unclear]		14	INITIALS
11-10-64	J. F. [unclear]		15	INITIALS
11-10-64	J. F. [unclear]		16	INITIALS
11-10-64	J. F. [unclear]		17	INITIALS
11-10-64	J. F. [unclear]		18	INITIALS
11-10-64	J. F. [unclear]		19	INITIALS
11-10-64	J. F. [unclear]		20	INITIALS
11-10-64	J. F. [unclear]		21	INITIALS
11-10-64	J. F. [unclear]		22	INITIALS
11-10-64	J. F. [unclear]		23	INITIALS
11-10-64	J. F. [unclear]		24	INITIALS
11-10-64	J. F. [unclear]		25	INITIALS
11-10-64	J. F. [unclear]		26	INITIALS
11-10-64	J. F. [unclear]		27	INITIALS
11-10-64	J. F. [unclear]		28	INITIALS
11-10-64	J. F. [unclear]		29	INITIALS
11-10-64	J. F. [unclear]		30	INITIALS
11-10-64	J. F. [unclear]		31	INITIALS
11-10-64	J. F. [unclear]		32	INITIALS
11-10-64	J. F. [unclear]		33	INITIALS
11-10-64	J. F. [unclear]		34	INITIALS
11-10-64	J. F. [unclear]		35	INITIALS

DATE	BY	CHKD	REV.	REVISIONS
11-10-64	J. F. [unclear]		1	INITIALS
11-10-64	J. F. [unclear]		2	INITIALS
11-10-64	J. F. [unclear]		3	INITIALS
11-10-64	J. F. [unclear]		4	INITIALS
11-10-64	J. F. [unclear]		5	INITIALS
11-10-64	J. F. [unclear]		6	INITIALS
11-10-64	J. F. [unclear]		7	INITIALS
11-10-64	J. F. [unclear]		8	INITIALS
11-10-64	J. F. [unclear]		9	INITIALS
11-10-64	J. F. [unclear]		10	INITIALS
11-10-64	J. F. [unclear]		11	INITIALS
11-10-64	J. F. [unclear]		12	INITIALS
11-10-64	J. F. [unclear]		13	INITIALS
11-10-64	J. F. [unclear]		14	INITIALS
11-10-64	J. F. [unclear]		15	INITIALS
11-10-64	J. F. [unclear]		16	INITIALS
11-10-64	J. F. [unclear]		17	INITIALS
11-10-64	J. F. [unclear]		18	INITIALS
11-10-64	J. F. [unclear]		19	INITIALS
11-10-64	J. F. [unclear]		20	INITIALS
11-10-64	J. F. [unclear]		21	INITIALS
11-10-64	J. F. [unclear]		22	INITIALS
11-10-64	J. F. [unclear]		23	INITIALS
11-10-64	J. F. [unclear]		24	INITIALS
11-10-64	J. F. [unclear]		25	INITIALS
11-10-64	J. F. [unclear]		26	INITIALS
11-10-64	J. F. [unclear]		27	INITIALS
11-10-64	J. F. [unclear]		28	INITIALS
11-10-64	J. F. [unclear]		29	INITIALS
11-10-64	J. F. [unclear]		30	INITIALS
11-10-64	J. F. [unclear]		31	INITIALS
11-10-64	J. F. [unclear]		32	INITIALS
11-10-64	J. F. [unclear]		33	INITIALS
11-10-64	J. F. [unclear]		34	INITIALS
11-10-64	J. F. [unclear]		35	INITIALS

DATE	BY	CHKD	REV.	REVISIONS
11-10-64	J. F. [unclear]		1	INITIALS
11-10-64	J. F. [unclear]		2	INITIALS
11-10-64	J. F. [unclear]		3	INITIALS
11-10-64	J. F. [unclear]		4	INITIALS
11-10-64	J. F. [unclear]		5	INITIALS
11-10-64	J. F. [unclear]		6	INITIALS
11-10-64	J. F. [unclear]		7	INITIALS
11-10-64	J. F. [unclear]		8	INITIALS
11-10-64	J. F. [unclear]		9	INITIALS
11-10-64	J. F. [unclear]		10	INITIALS
11-10-64	J. F. [unclear]		11	INITIALS
11-10-64	J. F. [unclear]		12	INITIALS
11-10-64	J. F. [unclear]		13	INITIALS
11-10-64	J. F. [unclear]		14	INITIALS
11-10-64	J. F. [unclear]		15	INITIALS
11-10-64	J. F. [unclear]		16	INITIALS
11-10-64	J. F. [unclear]		17	INITIALS
11-10-64	J. F. [unclear]		18	INITIALS
11-10-64	J. F. [unclear]		19	INITIALS
11-10-64	J. F. [unclear]		20	INITIALS
11-10-64	J. F. [unclear]		21	INITIALS
11-10-64	J. F. [unclear]		22	INITIALS
11-10-64	J. F. [unclear]		23	INITIALS
11-10-64	J. F. [unclear]		24	INITIALS
11-10-64	J. F. [unclear]		25	INITIALS
11-10-64	J. F. [unclear]		26	INITIALS
11-10-64	J. F. [unclear]		27	INITIALS
11-10-64	J. F. [unclear]		28	INITIALS
11-10-64	J. F. [unclear]		29	INITIALS
11-10-64	J. F. [unclear]		30	INITIALS
11-10-64	J. F. [unclear]		31	INITIALS
11-10-64	J. F. [unclear]		32	INITIALS
11-10-64	J. F. [unclear]		33	INITIALS
11-10-64	J. F. [unclear]		34	INITIALS
11-10-64	J. F. [unclear]		35	INITIALS

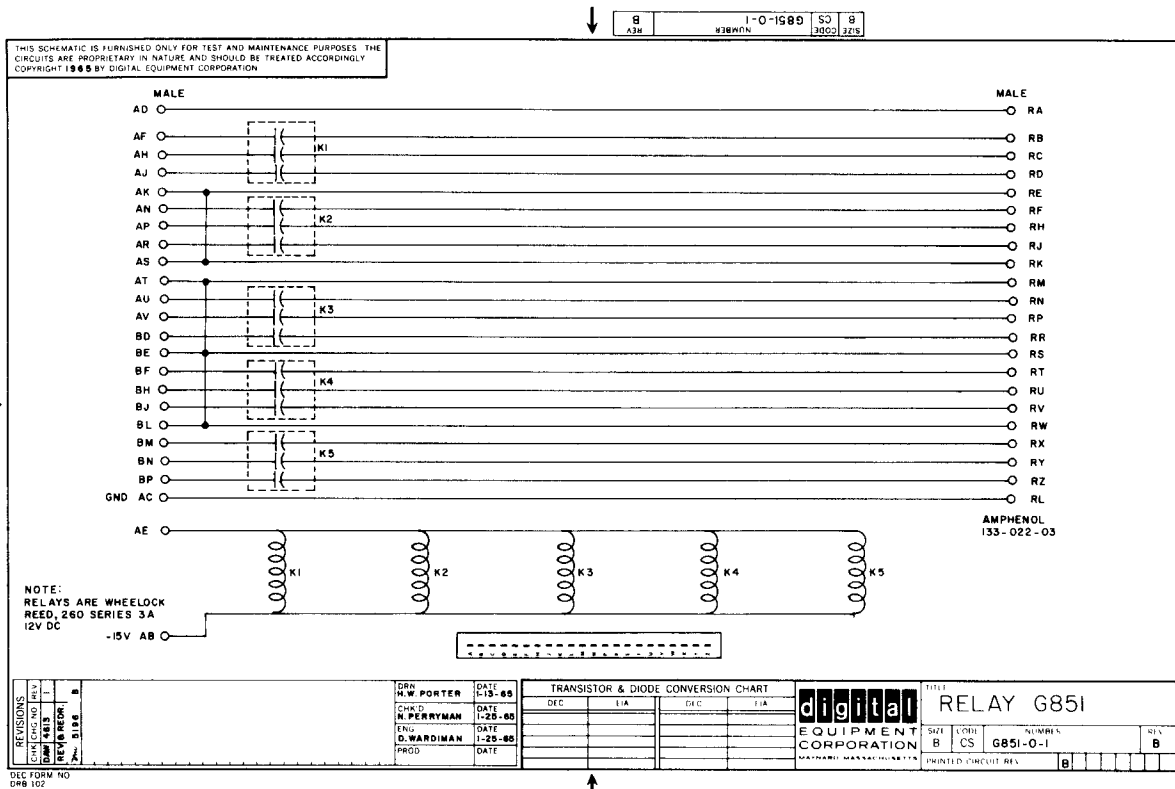
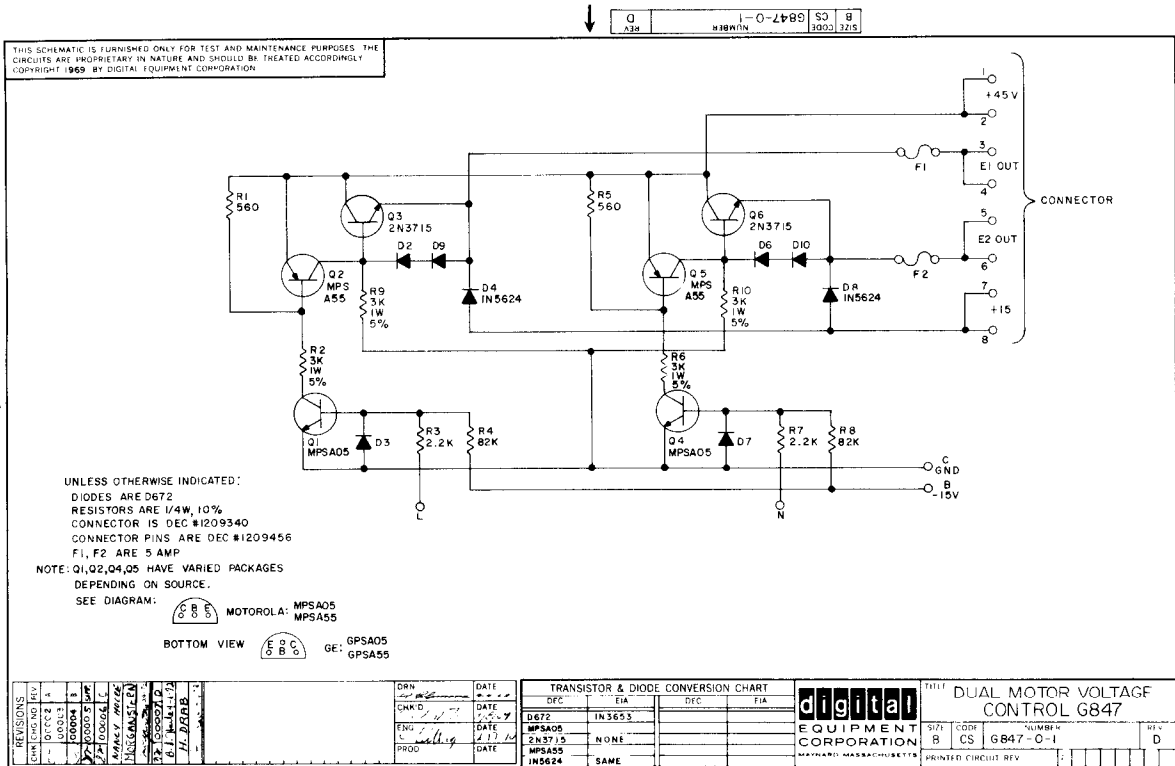

THIS SCHEMATIC IS FURNISHED ONLY FOR TEST AND MAINTENANCE PURPOSES THE CIRCUITS ARE PROPRIETARY IN NATURE AND SHOULD BE TREATED ACCORDINGLY
 COPYRIGHT 1969 BY DIGITAL EQUIPMENT CORPORATION

1-0-6580 SD 8
 #38M7N 100J 3215

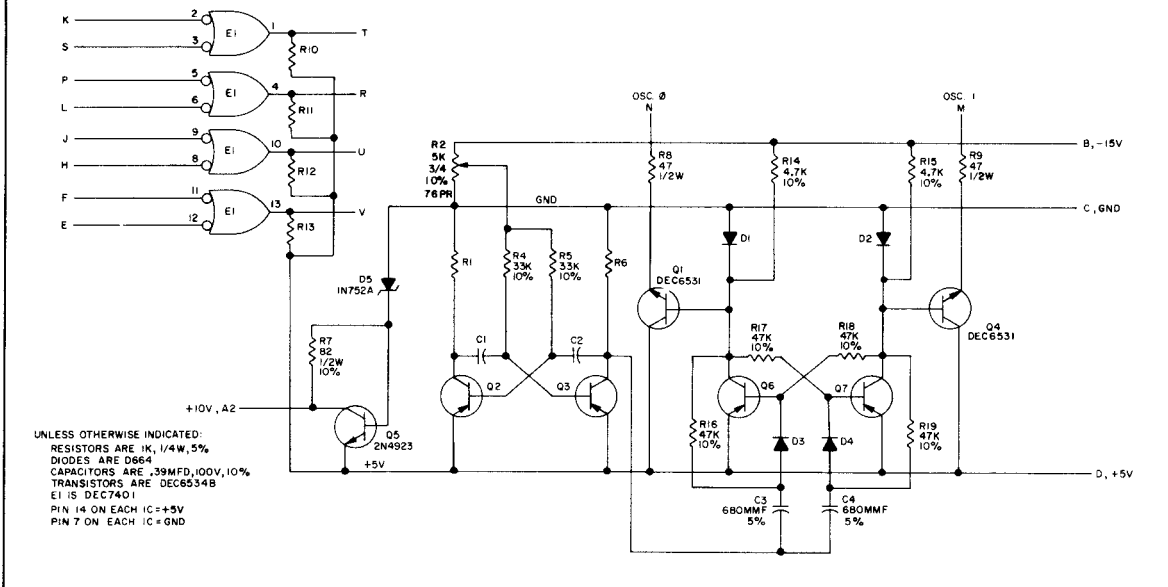

UNLESS OTHERWISE INDICATED:
 RESISTORS ARE 1/4W, 5%
 DIODES ARE D664
 CAPACITORS ARE .39MFD, 100V, 10%
 TRANSISTORS ARE DEC6534B
 E1 IS DEC7401
 PIN 14 ON EACH IC = +5V
 PIN 7 ON EACH IC = GND

REVISIONS CHG NO REV 1 1 2 1 3 1 4 1 5 1 6 1 7 1 8 1 9 1 10 1 11 1 12 1 13 1 14 1 15 1 16 1 17 1 18 1 19 1 20 1 21 1 22 1 23 1 24 1 25 1 26 1 27 1 28 1 29 1 30 1 31 1 32 1 33 1 34 1 35 1 36 1 37 1 38 1 39 1 40 1 41 1 42 1 43 1 44 1 45 1 46 1 47 1 48 1 49 1 50 1 51 1 52 1 53 1 54 1 55 1 56 1 57 1 58 1 59 1 60 1 61 1 62 1 63 1 64 1 65 1 66 1 67 1 68 1 69 1 70 1 71 1 72 1 73 1 74 1 75 1 76 1 77 1 78 1 79 1 80 1 81 1 82 1 83 1 84 1 85 1 86 1 87 1 88 1 89 1 90 1 91 1 92 1 93 1 94 1 95 1 96 1 97 1 98 1 99 1 100 1	DPN <i>BULLER</i> DATE <i>11/3/69</i> CHK'D <i>[Signature]</i> DATE <i>11/17/69</i> ENG <i>[Signature]</i> DATE <i>11/17/69</i> PROD <i>[Signature]</i> DATE <i>11/17/69</i>	TRANSISTOR & DIODE CONVERSION CHART DEC I FIA D664 IN3606 DEC6534B MP66534B DEC6531 MP65551 2N4923 SAME	TITLE CLOCK & REGULATOR G859 digital EQUIPMENT CORPORATION MAYNARD MASSACHUSETTS SIZE B CODE CS NUMBER 6859-0-1 REV C PRINTED CIRCUIT REV A
---	---	--	--

DEC FORM NO DB8 102

THIS SCHEMATIC IS FURNISHED ONLY FOR TEST AND MAINTENANCE PURPOSES THE CIRCUITS ARE PROPRIETARY IN NATURE AND SHOULD BE TREATED ACCORDINGLY
 COPYRIGHT 1969 BY DIGITAL EQUIPMENT CORPORATION

1-0-9899 SD 8
 #38M7N 100J 3215

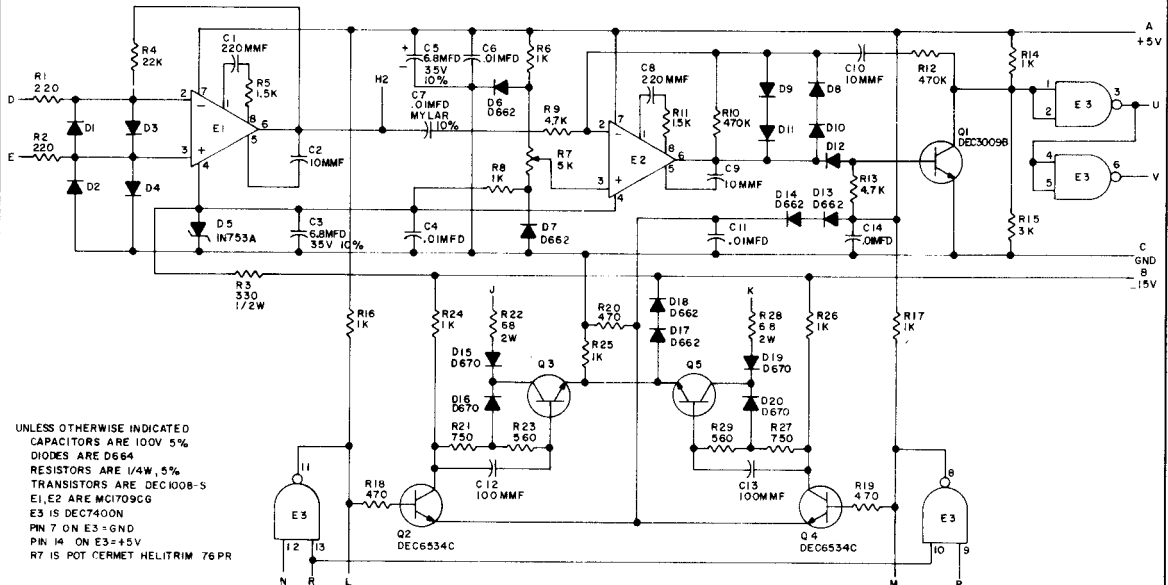

UNLESS OTHERWISE INDICATED:
 CAPACITORS ARE 100V, 5%
 DIODES ARE D664
 RESISTORS ARE 1/4W, 5%
 TRANSISTORS ARE DEC1008-S
 E1, E2 ARE MCI709CG
 E3 IS DEC7400N
 PIN 7 ON E3 = GND
 PIN 14 ON E3 = +5V
 R7 IS POT CERMET HELITRIM 76 PR

REVISIONS CHG NO REV 1 1 2 1 3 1 4 1 5 1 6 1 7 1 8 1 9 1 10 1 11 1 12 1 13 1 14 1 15 1 16 1 17 1 18 1 19 1 20 1 21 1 22 1 23 1 24 1 25 1 26 1 27 1 28 1 29 1 30 1 31 1 32 1 33 1 34 1 35 1 36 1 37 1 38 1 39 1 40 1 41 1 42 1 43 1 44 1 45 1 46 1 47 1 48 1 49 1 50 1 51 1 52 1 53 1 54 1 55 1 56 1 57 1 58 1 59 1 60 1 61 1 62 1 63 1 64 1 65 1 66 1 67 1 68 1 69 1 70 1 71 1 72 1 73 1 74 1 75 1 76 1 77 1 78 1 79 1 80 1 81 1 82 1 83 1 84 1 85 1 86 1 87 1 88 1 89 1 90 1 91 1 92 1 93 1 94 1 95 1 96 1 97 1 98 1 99 1 100 1	DPN <i>[Signature]</i> DATE <i>11/25/69</i> CHK'D <i>[Signature]</i> DATE <i>11/25/69</i> ENG <i>[Signature]</i> DATE <i>11/25/69</i> PROD <i>[Signature]</i> DATE <i>11/25/69</i>	TRANSISTOR & DIODE CONVERSION CHART DEC I FIA D664 IN3606 DEC1008-S MM1008 D662 IN645 D670 35ME DEC3009B 2N3009B DEC6534C MP66534C	TITLE MANCHESTER READER/WRIER G888 digital EQUIPMENT CORPORATION MAYNARD MASSACHUSETTS SIZE B CODE CS NUMBER 6888-0-1 REV C PRINTED CIRCUIT REV A
---	---	---	--

DEC FORM NO DB8 102

THIS SCHEMATIC IS FURNISHED ONLY FOR TEST AND MAINTENANCE PURPOSES. THE CIRCUITS ARE PROPRIETARY IN NATURE AND SHOULD BE TREATED ACCORDINGLY. COPYRIGHT 1967 BY DIGITAL EQUIPMENT CORPORATION

1-0-040M SC B
 43H 20001 2215

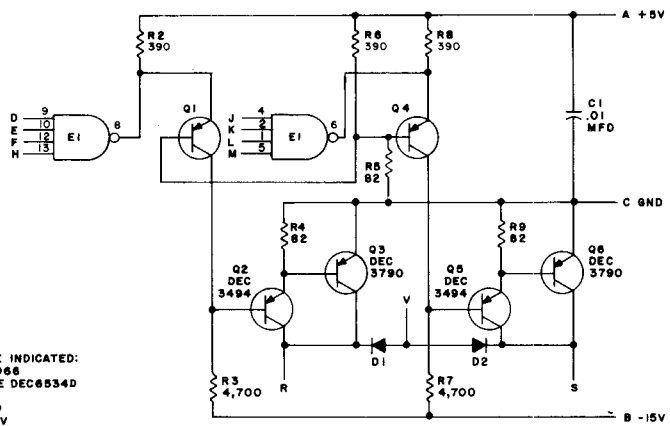

UNLESS OTHERWISE INDICATED:
 DIODES ARE MR2066
 TRANSISTORS ARE DEC6534D
 E1 IS DEC7420N
 PIN 7 ON IC = GND
 PIN 14 ON IC = +5V
 RESISTORS ARE 1/4W, 10%

PARTS LIST A-PL-M040-0-0

REV	DATE	TRANSISTOR & DIODE CONVERSION CHART				TITLE				
		DEC	EIA	DEC	EIA					
1	7/18/67	DEC3494	3AME			digital EQUIPMENT CORPORATION MAYNARD, MASSACHUSETTS	SOLENOID DRIVER M040	SIZE B CS	NUMBER M040-0-1	REV E
2	7/18/67	DEC3790	2N3790							
3	7/18/67	DEC6534D	MP85534							
4	7/18/67	MR2066	1N4003							

DEC FORM NO 098 102

THIS SCHEMATIC IS FURNISHED ONLY FOR TEST AND MAINTENANCE PURPOSES. THE CIRCUITS ARE PROPRIETARY IN NATURE AND SHOULD BE TREATED ACCORDINGLY. COPYRIGHT 1967 BY DIGITAL EQUIPMENT CORPORATION

1-0-202M SC B
 43H 20001 2215

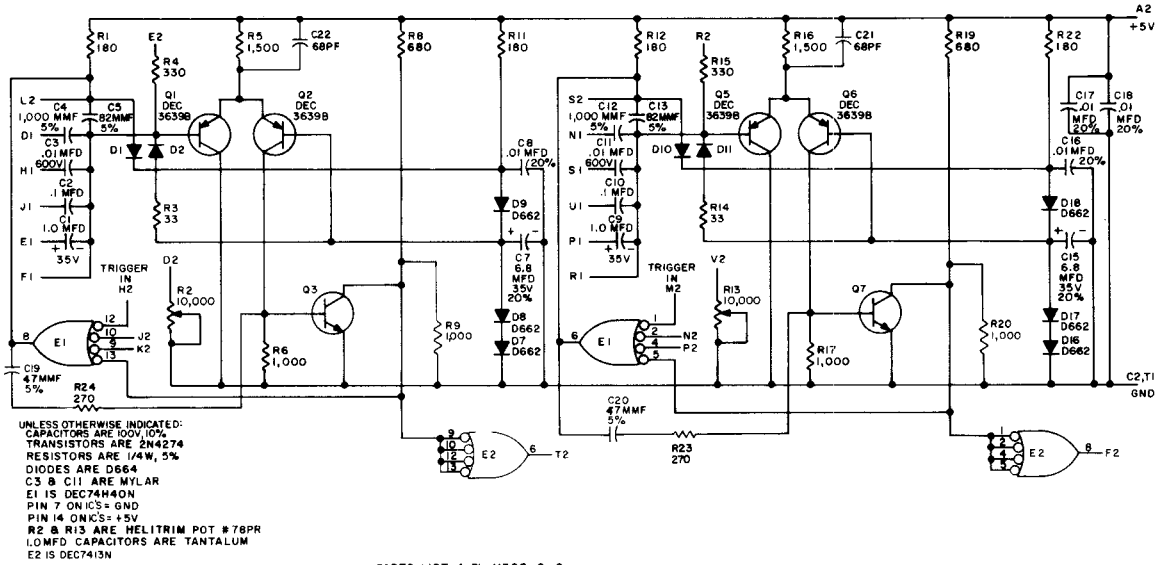

UNLESS OTHERWISE INDICATED:
 CAPACITORS ARE 100V, 10%
 TRANSISTORS ARE 2N4274
 RESISTORS ARE 1/4W, 5%
 DIODES ARE D664
 C3 & C11 ARE MYLAR
 E1 IS DEC74440N
 PIN 7 ON IC'S = GND
 PIN 14 ON IC'S = +5V
 R2 & R13 ARE HELIOTRIM POT # 78PR
 1.0MFD CAPACITORS ARE TANTALUM
 E2 IS DEC7413N

PARTS LIST A-PL-M302-0-0

REV	DATE	TRANSISTOR & DIODE CONVERSION CHART				TITLE				
		DEC	EIA	DEC	EIA					
1	7/18/67	2N4274	3AME			digital EQUIPMENT CORPORATION MAYNARD, MASSACHUSETTS	ONE SHOT DELAY M302	SIZE B CS	NUMBER M302-0-1	REV L
2	7/18/67	DEC3494	2N3790							
3	7/18/67	D662	1N4643							
4	7/18/67	D664	1N3606							

DEC FORM NO 098 102

THIS SCHEMATIC IS FURNISHED ONLY FOR TEST AND MAINTENANCE PURPOSES. THE CIRCUITS ARE PROPRIETARY IN NATURE AND SHOULD BE TREATED ACCORDINGLY. COPYRIGHT 1967 BY DIGITAL EQUIPMENT CORPORATION.

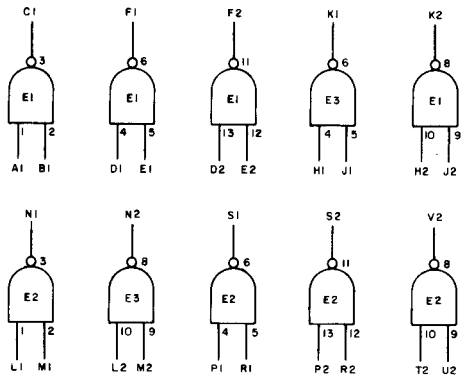

+5V ——— A2
 NOT USED -15V ——— B2
 GND ——— C2, T1

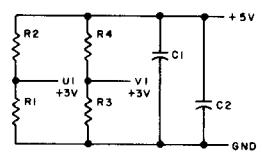

NOTES:
 PIN 7 ON EACH IC = GND
 PIN 14 ON EACH IC = +5V

E1 THRU E3	INTEGRATED CKT. DEC7400N	1905575
R1 AND R3	RES. 750 1/4W 5% CC	1301401
R2 AND R4	RES. 330 1/4W 10% CC	1300293
C1 AND C2	CAP. .01MFD 100V 20% DISC	1001610
PARTS LIST		A-PL-MI3-0-0
REFERENCE DESIGNATION	DESCRIPTION	PART NO.

REV.	DATE	BY	CHK'D
1	3-15-67	M. Waller	
2	4-21-67	M. Waller	
3	4-21-67	M. Waller	

DATE	BY	CHK'D
3-15-67	M. Waller	
4-21-67	M. Waller	
4-21-67	M. Waller	

DEC	EIA	DEC	EIA

digital EQUIPMENT CORPORATION
 10-2 INPUT NAND GATES MI3
 PARTS LIST
 SIZE B CODE CS MI3-0-1 REV C
 PRINTED CIRCUIT REV. D

DEC FORM NO. DRB 102

THIS SCHEMATIC IS FURNISHED ONLY FOR TEST AND MAINTENANCE PURPOSES. THE CIRCUITS ARE PROPRIETARY IN NATURE AND SHOULD BE TREATED ACCORDINGLY. COPYRIGHT 1967 BY DIGITAL EQUIPMENT CORPORATION.

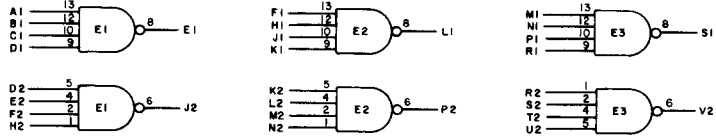

+5V ——— A2
 NOT USED -15V ——— B2
 GND ——— C2, T1

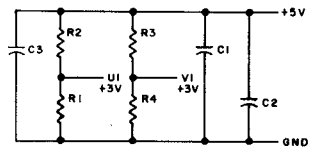

NOTES:
 PIN 7 ON EACH IC = GND
 PIN 14 ON EACH IC = +5V

E1 THRU E3	INTEGRATED CKT. DEC7420N	1905577
R1 B R4	RES. 750 1/4W 5% CC	1301401
R2 B R3	RES. 330 1/4W 10% CC	1300293
C1 THRU C3	CAP. .01MFD 100V 20% DISC	1001610
PARTS LIST		A-PL-MI7-0-0
REFERENCE DESIGNATION	DESCRIPTION	PART NO.

REV.	DATE	BY	CHK'D
1	3-15-67	M. Waller	
2	4-21-67	M. Waller	
3	4-21-67	M. Waller	

DATE	BY	CHK'D
3-15-67	M. Waller	
4-21-67	M. Waller	
4-21-67	M. Waller	

DEC	EIA	DEC	EIA

digital EQUIPMENT CORPORATION
 6-4 INPUT NAND GATES MI7
 PARTS LIST
 SIZE B CODE CS MI7-0-1 REV E
 PRINTED CIRCUIT REV. E

DEC FORM NO. DRB 102

THIS SCHEMATIC IS FURNISHED ONLY FOR TEST AND MAINTENANCE PURPOSES. THE CIRCUITS ARE PROPRIETARY IN NATURE AND SHOULD BE TREATED ACCORDINGLY. COPYRIGHT © 1970 BY DIGITAL EQUIPMENT CORPORATION.

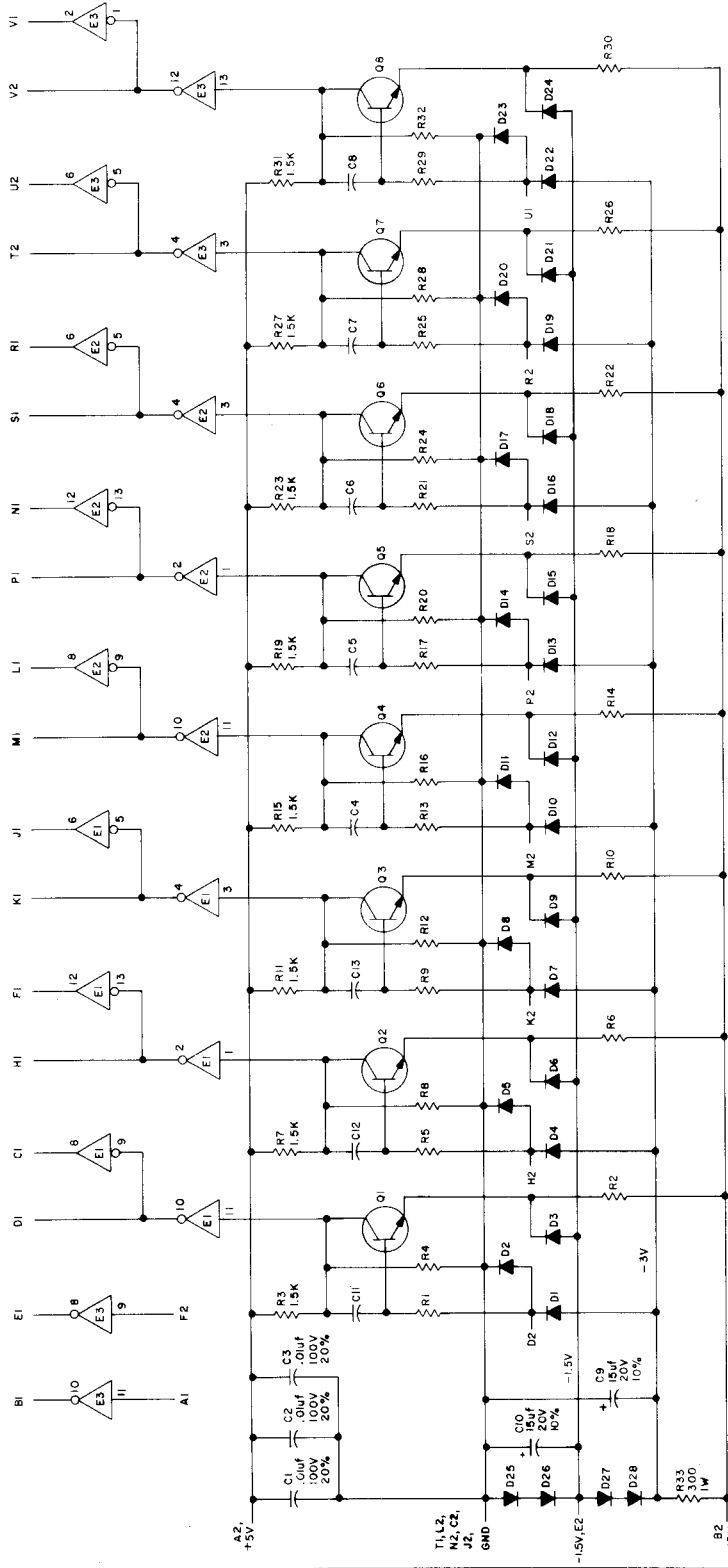

UNLESS OTHERWISE INDICATED:
 RESISTORS ARE 3K, 1/4W, 5%
 DIODES ARE D664
 CAPACITORS ARE 100 pf, 100V, 5%
 TRANSISTORS ARE 2N3009B
 ICs ARE DEC/M04

REV A
 NUMBER M531-0-1
 CS 3245

REVISIONS		DATE		BY	
1	0001				
2	0002				
3	0003				
4	0004				
5	0005				
6	0006				
7	0007				
8	0008				
9	0009				
10	0010				
11	0011				
12	0012				
13	0013				
14	0014				
15	0015				
16	0016				
17	0017				
18	0018				
19	0019				
20	0020				
21	0021				
22	0022				
23	0023				
24	0024				
25	0025				
26	0026				
27	0027				
28	0028				
29	0029				
30	0030				
31	0031				
32	0032				
33	0033				
34	0034				
35	0035				
36	0036				
37	0037				
38	0038				
39	0039				
40	0040				
41	0041				
42	0042				
43	0043				
44	0044				
45	0045				
46	0046				
47	0047				
48	0048				
49	0049				
50	0050				
51	0051				
52	0052				
53	0053				
54	0054				
55	0055				
56	0056				
57	0057				
58	0058				
59	0059				
60	0060				
61	0061				
62	0062				
63	0063				
64	0064				
65	0065				
66	0066				
67	0067				
68	0068				
69	0069				
70	0070				
71	0071				
72	0072				
73	0073				
74	0074				
75	0075				
76	0076				
77	0077				
78	0078				
79	0079				
80	0080				
81	0081				
82	0082				
83	0083				
84	0084				
85	0085				
86	0086				
87	0087				
88	0088				
89	0089				
90	0090				
91	0091				
92	0092				
93	0093				
94	0094				
95	0095				
96	0096				
97	0097				
98	0098				
99	0099				
100	0100				

TRANSISTOR & DIODE CONVERSION CHART

DEC	EIA
2N3009B	2N3009
06E4	06E4

DATE: 11/11/70
 DRAWN: [Signature]
 CHECKED: [Signature]
 APPROVED: [Signature]

TITLE: NEGATIVE BUS CONVERTER
 SIZE: CODE NUMBER
 EQUIPMENT CODE CS M531-0-1
 CORPORATION C CS M531-0-1
 PRINTED CIRCUIT REV: A

THIS SCHEMATIC IS FURNISHED ONLY FOR TEST AND MAINTENANCE PURPOSES. THE CIRCUITS ARE PROPRIETARY IN NATURE AND SHOULD BE TREATED ACCORDINGLY. COPYRIGHT 1968 BY DIGITAL EQUIPMENT CORPORATION

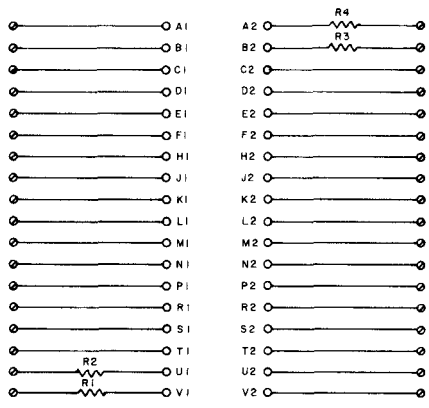

⊙ SPLIT LUG

R1 - R4	RES. 10 1/4 W 10% CC	1300170
PARTS LIST	DESCRIPTION	A-PL-M908-0-0
REFERENCE DESIGNATION	PARTS LIST	PART NO.

REVISIONS CHKD ENG PRD	DRN DATE	DATE	TRANSISTOR & DIODE CONVERSION CHART		 TITLE CONNECTOR MODULE M908 EQUIPMENT CORPORATION MAYNARD, MASSACHUSETTS PRINTED CIRCUIT REV
	CHK'D DATE	DATE	DEC	EIA	
	ENG DATE	DATE	DEC	EIA	
	PRD DATE	DATE	DEC	EIA	
DEC FORM NO DRB 102					SIZE CODE NUMBER REV B CS M908-0-1 A-PL-M908-0-0

THIS SCHEMATIC IS FURNISHED ONLY FOR TEST AND MAINTENANCE PURPOSES. THE CIRCUITS ARE PROPRIETARY IN NATURE AND SHOULD BE TREATED ACCORDINGLY. COPYRIGHT 1968 BY DIGITAL EQUIPMENT CORPORATION

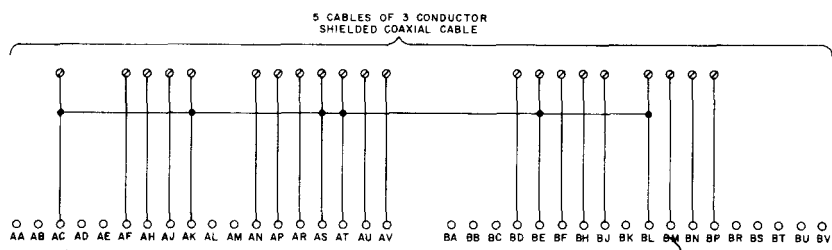

NOTE:
 ⊙ ARE SPLIT LUGS

PARTS LIST IS A-PL-W032-0-0

REVISIONS CHKD ENG PRD	DRN DATE	DATE	TRANSISTOR & DIODE CONVERSION CHART		 TITLE CONNECTOR W032 EQUIPMENT CORPORATION MAYNARD, MASSACHUSETTS PRINTED CIRCUIT REV
	CHK'D DATE	DATE	DEC	EIA	
	ENG DATE	DATE	DEC	EIA	
	PRD DATE	DATE	DEC	EIA	
DEC FORM NO DRB 102					SIZE CODE NUMBER REV B CS W032-0-1 A-PL-W032-0-0

THIS SCHEMATIC IS FURNISHED ONLY FOR TEST AND MAINTENANCE PURPOSES THE CIRCUITS ARE PROPRIETARY IN NATURE AND SHOULD BE TREATED ACCORDINGLY COPYRIGHT 1969 BY DIGITAL EQUIPMENT CORPORATION

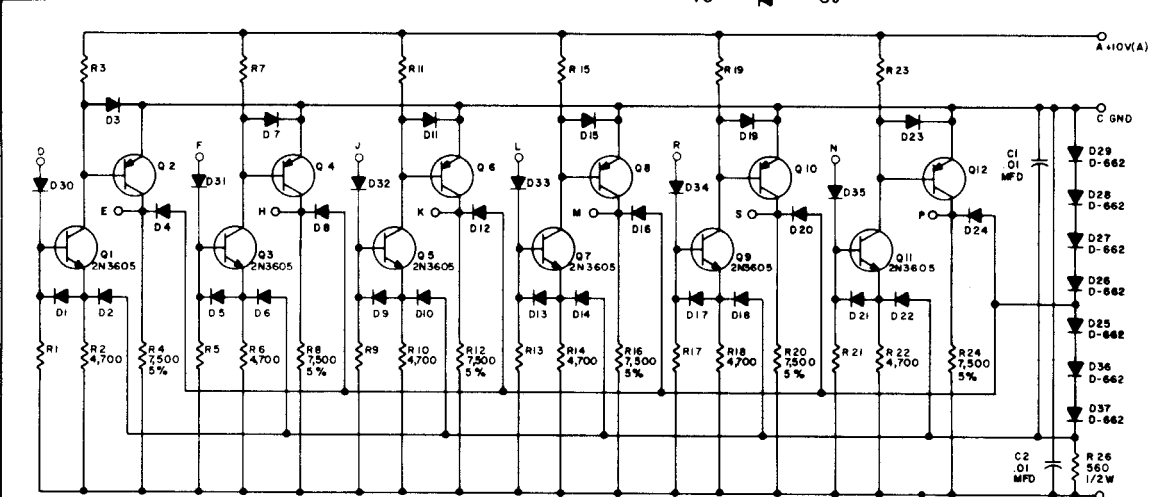

UNLESS OTHERWISE INDICATED: TRANSISTORS ARE DEC 2894-1B DIODES ARE D-664 RESISTORS ARE 10,000; 1/4W; 10% RESISTORS ARE 1/4W; 10%
 NOTE: TO BE USED WHEN SOLID STATE DEC TAPE TU55 IS CONNECTED TO A CONTROL THAT HAS RELAY DRIVERS (550,551,552)

REVISIONS CHK'D BY: [] DATE: [] ENG: [] DATE: [] PRD: []	DRN	T. MAHN	DATE	5-27-65	TRANSISTOR & DIODE CONVERSION CHART			TITLE digital LEVEL AMPLIFIER W513 EQUIPMENT CORPORATION MAYNARD, MASSACHUSETTS PRINTED CIRCUIT REV
	CHK'D	R. SILVERMAN	DATE	8-4-65	DEC	EIA	DEC	
	ENG.	D. WARDIMON	DATE	8-3-68	DEC 2894-1B	NONE		
	PRD.		DATE		2N3605	SAME		

DEC FORM NO 09B 102

THIS SCHEMATIC IS FURNISHED ONLY FOR TEST AND MAINTENANCE PURPOSES THE CIRCUITS ARE PROPRIETARY IN NATURE AND SHOULD BE TREATED ACCORDINGLY COPYRIGHT 1969 BY DIGITAL EQUIPMENT CORPORATION

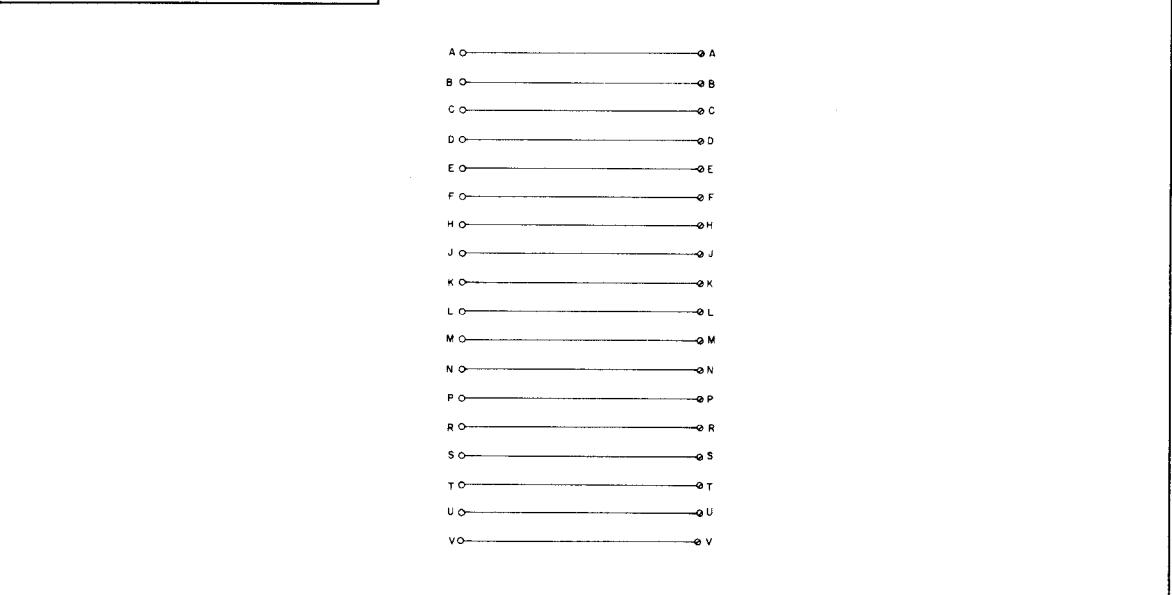

REVISIONS CHK'D BY: [] DATE: [] ENG: [] DATE: [] PRD: []	DRN		DATE		TRANSISTOR & DIODE CONVERSION CHART			TITLE digital BLANK MODULE W990 EQUIPMENT CORPORATION MAYNARD, MASSACHUSETTS PRINTED CIRCUIT REV
	CHK'D		DATE		DEC	EIA	DEC	
	ENG.		DATE					
	PRD.		DATE					

DEC FORM NO 09B 102

READER'S COMMENTS

**TU56 DEctape TRANSPORT
MAINTENANCE MANUAL
DEC-00-HRTC-D**

Your comments and suggestions will help us in our continuous effort to improve the quality and usefulness of our publications.

What is your general reaction to this manual? In your judgment is it complete, accurate, well organized, well written, etc.? Is it easy to use? _____

What features are most useful? _____

What faults do you find with the manual? _____

Does this manual satisfy the need you think it was intended to satisfy? _____

Does it satisfy *your* needs? _____ Why? _____

Would you please indicate any factual errors you have found. _____

Please describe your position. _____

Name _____ Organization _____

Street _____ Department _____

City _____ State _____ Zip or Country _____

