

60 Series
Multi-User Software
Development
Unit

TNIX

8560 Series Hardware Installation Guide

*Please check for change information
at the rear of this manual*

WARNING

THE FOLLOWING SERVICING INSTRUCTIONS ARE FOR USE BY QUALIFIED PERSONNEL ONLY. TO AVOID PERSONAL INJURY, DO NOT PERFORM ANY SERVICING OTHER THAN THAT CONTAINED IN OPERATING INSTRUCTIONS UNLESS YOU ARE QUALIFIED TO DO SO. REFER TO OPERATORS SAFETY SUMMARY AND SERVICE SAFETY SUMMARY PRIOR TO PERFORMING ANY SERVICE.

Copyright © 1984 by Tektronix, Inc. All rights reserved. Contents of this publication may not be reproduced in any form without the permission of Tektronix, Inc.

Products of Tektronix, Inc. and its subsidiaries are covered by U.S. and foreign patents and/or pending patents.

TEKTRONIX, TEK, SCOPE-MOBILE, and  are registered trademarks of Tektronix, Inc. TELEQUIPMENT is a registered trademark of Tektronix U.K. Limited.

There is no implied warranty of fitness for a particular purpose. Tektronix, Inc. is not liable for consequential damages.

Specification and price change privileges are reserved.

Printed in U.S.A.

Section 4 INSTALLATION OVERVIEW

| | Page |
|---|------|
| Introduction | 4-1 |
| First-Time Installation (Basic System) | 4-1 |
| What Is an 8560? | 4-5 |
| Software | 4-5 |
| Hardware | 4-5 |
| Main Interconnect Board | 4-6 |
| LSI-11/23 Processor | 4-6 |
| LSI-11/73 Processor | 4-6 |
| System Memory | 4-6 |
| Mass Storage | 4-7 |
| MSC Controller Board | 4-7 |
| Utility Board | 4-7 |
| I/O Processor | 4-7 |
| Communications Adapters | 4-8 |

ILLUSTRATIONS

| Fig. No. | | Page |
|-------------|---|------|
| 4-1 | First-time installation procedure | 4-2 |

OPERATORS SAFETY SUMMARY

The general safety information in this part of the summary is for both operating and servicing personnel. Specific warnings and cautions will be found throughout the manual where they apply, but may not appear in this summary.

TERMS

In This Manual

CAUTION statements identify conditions or practices that could result in damage to the equipment or other property.

WARNING statements identify conditions or practices that could result in personal injury or loss of life.

As Marked on Equipment

CAUTION indicates a personal injury hazard not immediately accessible as you read the marking, or a hazard to property including the equipment itself.

DANGER indicates a personal injury hazard immediately accessible as you read the marking.

SYMBOLS

As Marked on Equipment

 **DANGER** high voltage.

 Protective ground (earth) terminal.

 **ATTENTION** - Refer to manual.

SERVICING SAFETY SUMMARY

FOR QUALIFIED SERVICE PERSONNEL ONLY

(Refer also to the preceding Operators Safety Summary)

Do Not Service Alone

Do not perform internal service or adjustment of this product unless another person capable of rendering first aid and resuscitation is present.

Use Care When Servicing With Power On

Dangerous voltages exist at several points in this product. To avoid personal injury, do not touch exposed connections and components while power is on.

SAFETY PRECAUTIONS

Grounding the Product

This product is grounded through the grounding conductor in the power cord. To avoid electrical shock, plug the power cord into a properly wired receptacle before connecting to the equipment's power input terminals. A protective ground connection by way of the grounding conductor in the power cord is essential for safe operation.

Use the Proper Power Cord

- Use only the power cord and connector specified for your product.
- Use only a power cord that is in good condition.
- Refer cord and connector changes to qualified service personnel.

Use the Proper Fuse

To avoid fire hazard, use only the fuse specified in the parts list for your product. Be sure the fuse is identical in type, voltage rating, and current rating.

Refer fuse replacement to qualified service personnel.

Do Not Operate in Explosive Atmospheres

To avoid explosion, do not operate this product in an atmosphere of explosive gases unless it has been specifically certified for such operation.

Do Not Remove Covers or Panels

To avoid personal injury, do not remove the product covers or panels. Do not operate the product without the covers and panels properly installed.

Disconnect power before removing protective panels, soldering, or replacing components.

Power Source

The product is designed to operate from a power source that will not apply more than 250 volts rms between the supply conductors or between either supply conductor and ground. A protective ground connection by way of the grounding conductor in the power cord is essential for safe operation.

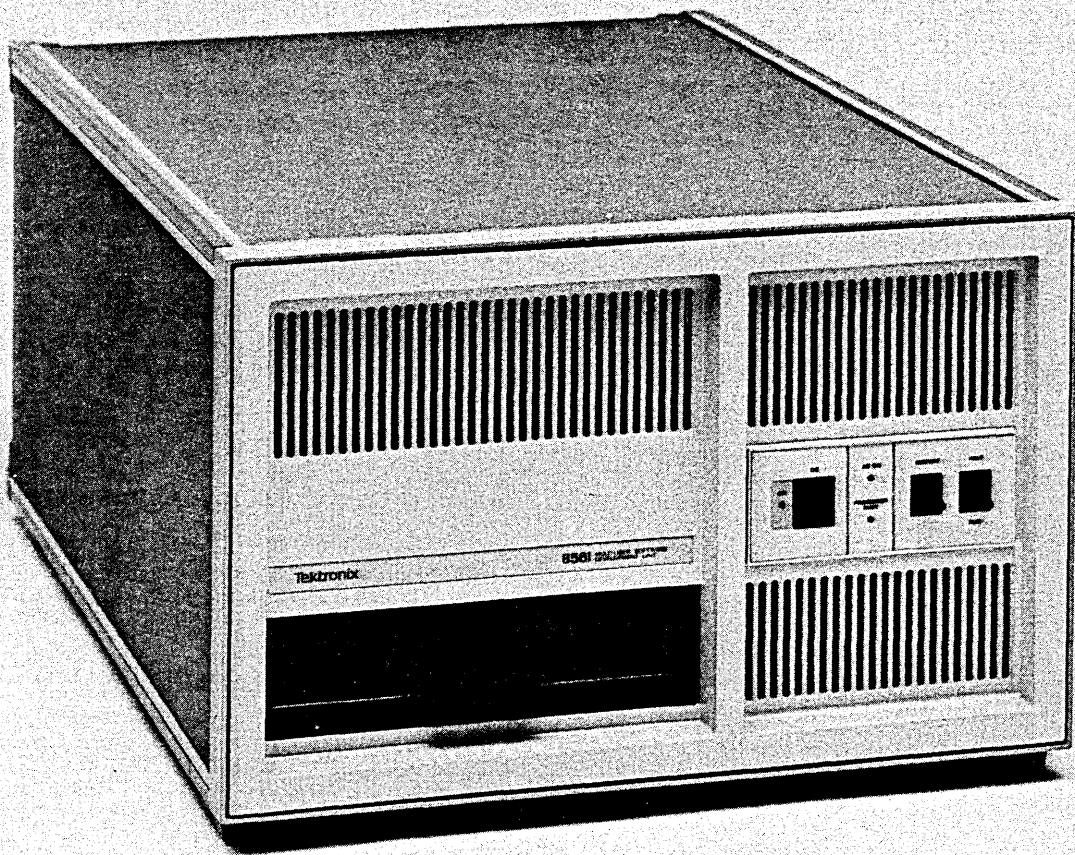

5049-1

856x Multi-User Software Development Unit

Section 4

INSTALLATION OVERVIEW

INTRODUCTION

This section provides a flowchart to guide you through first-time installation of your 8560 system. This section also contains a brief functional description of the TEKTRONIX 8560 Series Multi-User Software Development Unit (MUSDU).

NOTE

Unless otherwise specified, all references to the 8560 Series MUSDU refer to the 8560 (SN B100000 and above), the 8561 (SN B100000 and above), and the 8562.

FIRST-TIME INSTALLATION (BASIC SYSTEM)

Figure 4-1 is an annotated flowchart that shows you how to install and verify a basic system consisting of an 8560 Series MUSDU and a terminal. The flowchart shows the major installation steps and tells where to find the appropriate installation information in this manual.

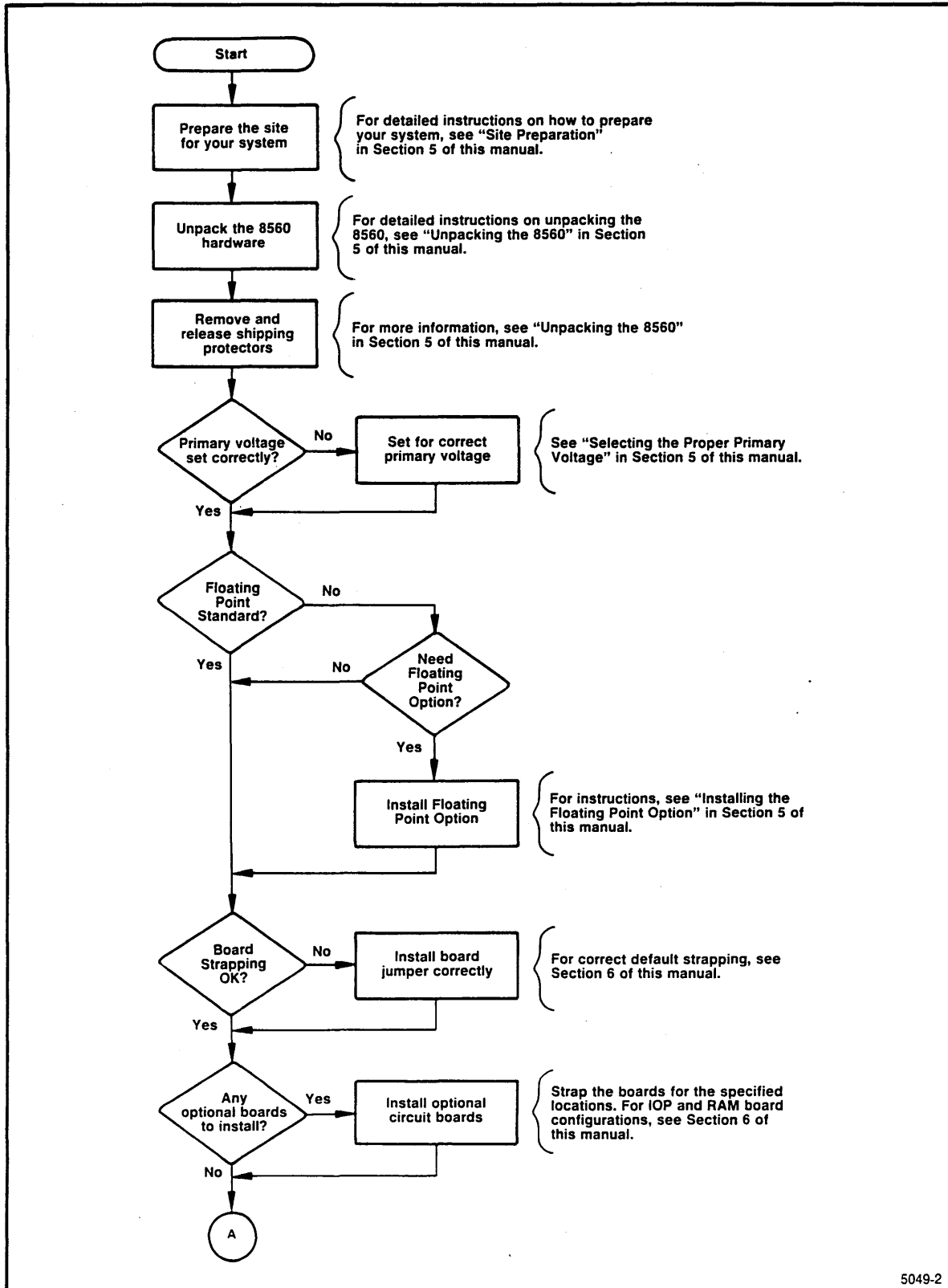

Fig. 4-1. First-time installation procedure (Part 1 of 3).

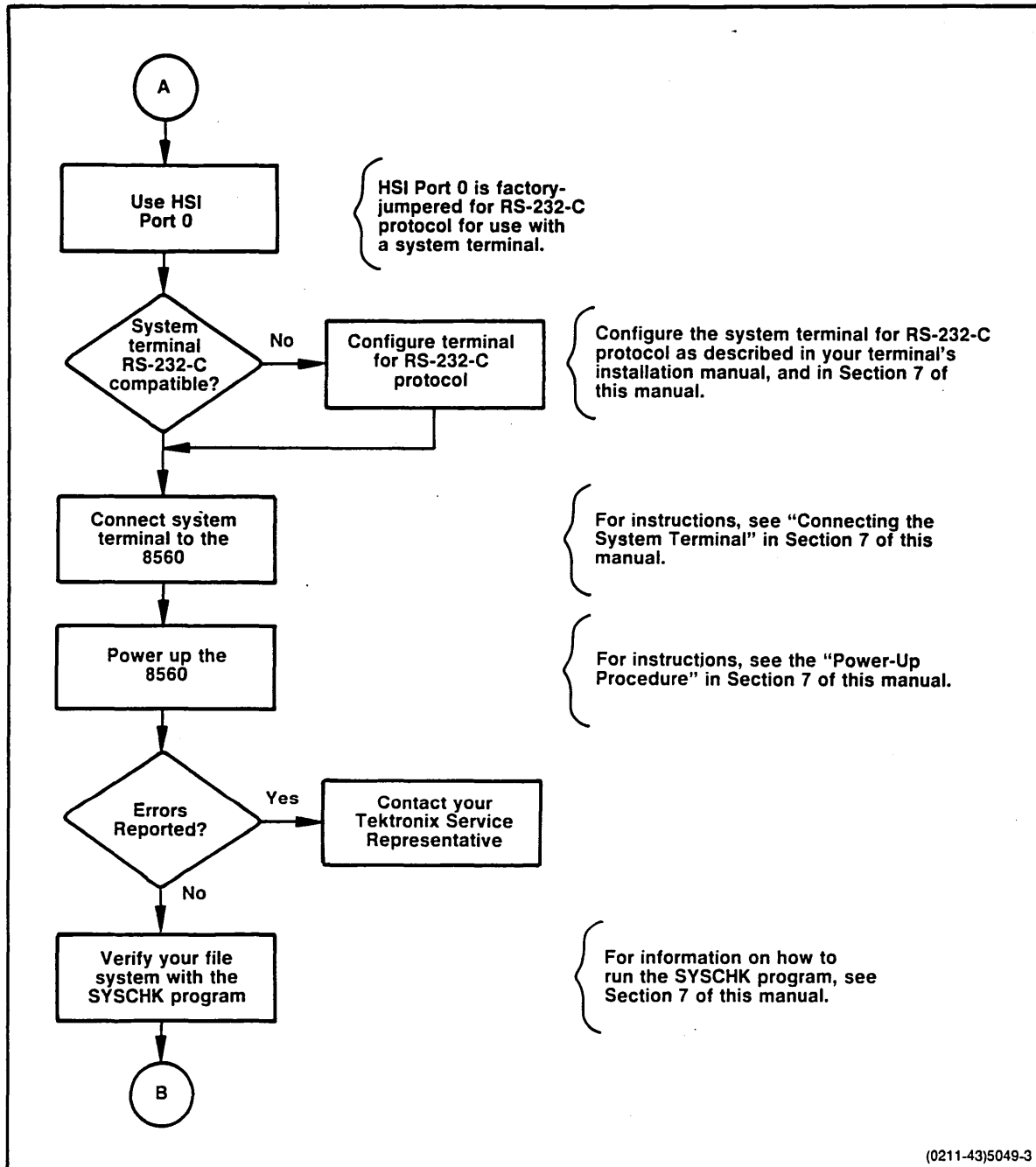

Fig. 4-1. First-time installation procedure (Part 2 of 3).

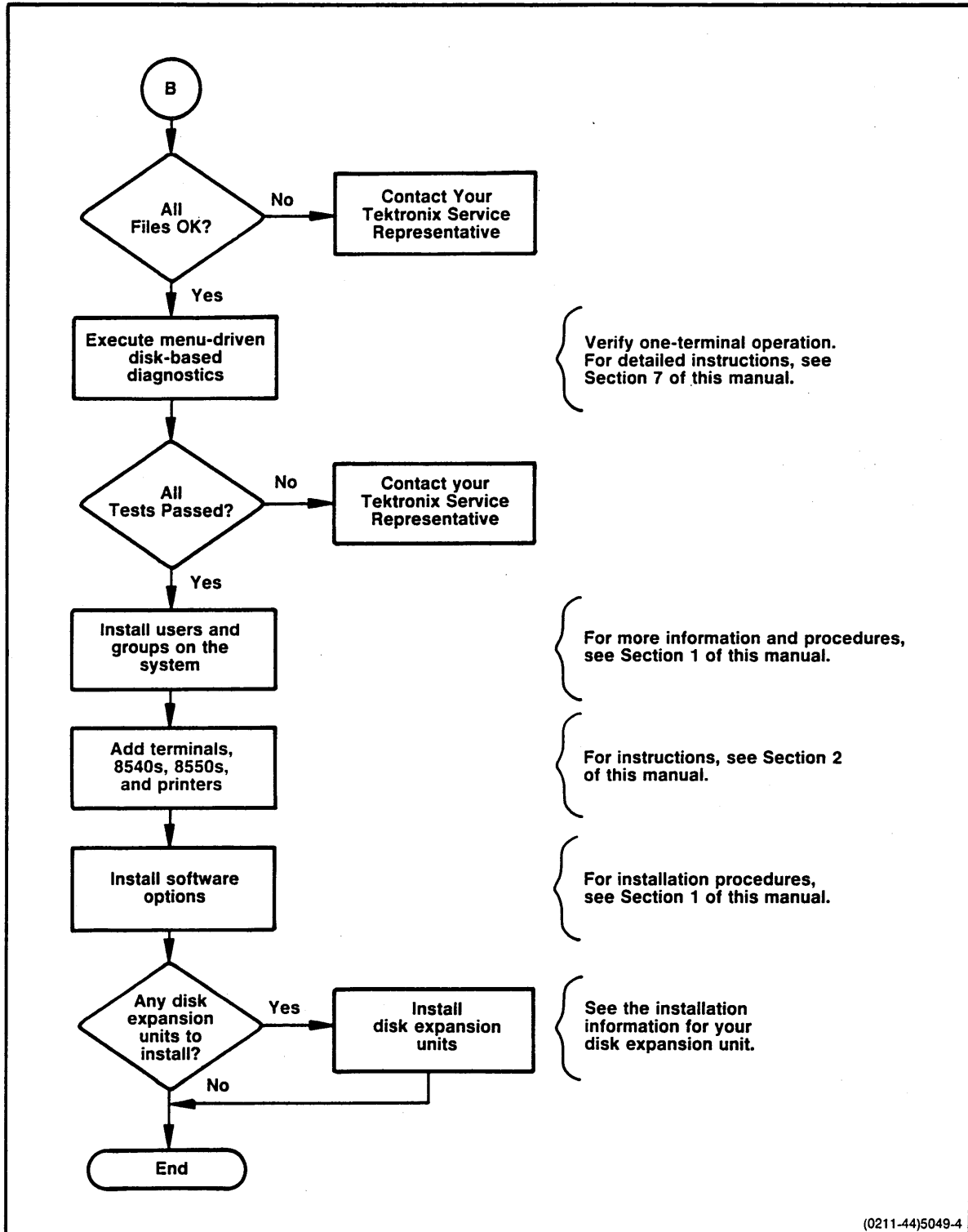

Fig. 4-1. First-time installation procedure (Part 3 of 3).

WHAT IS AN 8560?

The 8560 is a self-contained computer. It normally operates with one or more (up to eight) user workstations, each consisting of an 8540 Integration Unit and/or a terminal. The resulting integrated development system allows users to create, edit, assemble, load, execute, and debug user-written programs.

The 8560 Series MUSDU helps users develop and debug software by providing those tools most required in any development system:

- **Editors**, which allow users to create the text of a program
- **Assemblers**, to change an assembly-language program into machine language
- **Compilers**, which allow the use of a high-level language for easier program development
- **Debugging capabilities**, to monitor and evaluate a program as it is being run

Software

The 8560 TNIX operating system software is contained on a hard disk drive. The operating system used is a modified version of the Bell Laboratories UNIX(tm) Version 7.0 operating system. The operating system is also contained on a set of flexible disks to permit reloading of the hard disk when required.

The TNIX operating system enables the 8560 to function as a host computer to the 8540 Integration Unit. The 8540 uses a ROM-based operating system, OS/40, to perform prototype development operations, such as emulation and program execution. The OS/40 system interfaces with TNIX for system operations such as editing, assembly, compiling, and communications.

For a complete description of the OS/40 operating system, refer to the *8540 System Users Manual*. The 8560's TNIX operating system is described in your *8560 Series System Users Manual*.

Hardware

The 8560 consists of the following major hardware components:

- Main Interconnect Board
- LSI-11 Processor
- System memory
- A double-sided, double-density, flexible disk drive
- A Winchester-technology hard disk drive
- Mass Storage Controller (MSC) Board
- Utility Board
- I/O Processor

The following paragraphs briefly describe each of these components.

Main Interconnect Board

The Main Interconnect Board carries the LSI-11 processor's Q-bus to all the circuit boards in the 8560. The Main Interconnect Board also provides the necessary interconnections between circuit boards and any I/O devices in the system. I/O signals are distributed between the circuit boards and the I/O destination by the Main Interconnect Board. Therefore, each circuit board that processes I/O functions is assigned a dedicated slot in the Main Interconnect Board.

LSI-11/23 Processor

The main controller for the 8560 and 8561 is a Digital Equipment Corporation LSI-11/23 microcomputer. The LSI-11/23 is contained on one dual-height, multi-layer, plug-in circuit board. The LSI-11/23 includes such features as:

- Asynchronous bus operation, which allows the processor and system components to run at their highest possible speed
- Memory management for 128K bytes of multi-user program space
- 16-bit word or 8-bit byte addressable locations
- Direct Memory Access (DMA) to allow peripheral devices to access memory without interrupting processor operation

LSI-11/73 Processor

The main controller for the 8562 is a Digital Equipment Corporation LSI-11/73 microcomputer. The LSI-11/73 is contained on one dual-height, multi-layer, plug-in circuit board. The LSI-11/73 includes such features as:

- J11 CMOS microprocessor with integral floating point processor, memory addressing up to 4M bytes, separate instruction and data space, and PDP-11/70 memory management compatibility
- 8K bytes of on-board cache memory
- 22-bit Q-Bus interface

System Memory

The basic system memory of an 8560 MUSDU is composed of up to two boards of dynamic RAM. Memory boards are configured in either 256K bytes or 512K bytes. Therefore, any 8560 system memory may be expanded up to 1M bytes. Each board contains selectable jumpers that allow the board to be configured as either the high or low bank of LSI-11 memory.

Mass Storage

To provide the large amount of peripheral mass storage required, each 8560 has one flexible disk drive and up to two 5-1/4" Winchester-technology hard disk drives. The flexible disk drive provides approximately 1.2M bytes of formatted capacity on a double-sided, double-density, 8-inch disk. Either single-density or double-density read/write format may be selected. Primary mass storage for the 8560 is provided by the hard disk drive(s). Additional hard disk drives may be connected to the 8560.

MSC Controller Board

The 8560 Mass Storage Controller (MSC) Board is intended to handle all disk I/O for the 8560 unit. The SCSI bus is used to access one or two Winchester-type drives through a Xebec Disk Controller. Additional Winchester drives or a tape back-up unit may also be accessed using SCSI-compatible controllers. The MSC Board drives the Qume flexible disk drive directly. The processor used on the MSC Board is the Intel 80186. It operates at an 8 MHz clock rate. All DMA transfers are treated as memory-to-memory. DMA transfers can occur at a 1 MWord/second rate (assuming no wait states).

Utility Board

The Utility Board provides support for functions not supported by other boards in the 8560. Features supplied by the Utility Board include:

- Two RS-232-C interface ports
- LSI-11 Line-Time Clock (LTC) function
- Bootstrap ROM
- Debug ROM
- Front Panel functions (RESTART, RUN/HALT)
- Bus termination resistors
- LSI-11 power up/down sequencing

I/O Processor

The I/O Processor (IOP) consists of one or two boards which provide up to eight full-duplex, serial-interface channels.

The IOP uses memory queues in the 8560 system memory to communicate with the LSI-11. The IOP provides I/O processing capability that would otherwise be assigned to the LSI-11.

Communications Adapters

Two small circuit boards are used in the interface between the I/O Processor and external devices:

- The I/O Adapter (IOA) Board permits selection of either RS-422 or RS-232-C protocol for the HSI I/O ports and performs the necessary translation to RS-422 or RS-232-C compatible voltage levels.
- All I/O connectors are mounted on the I/O Connector (IOC) Board located on the rear panel of the 8560 mainframe. In addition to the HSI I/O connectors (two, four, or eight, depending on system configuration), there are two dedicated RS-232-C connectors for interface with line printers.

Section 5 SITE PREPARATION AND UNPACKING

| | Page |
|---|------|
| Introduction | 5-1 |
| Site Preparation | 5-1 |
| Space Requirements | 5-2 |
| Cable Lengths | 5-3 |
| Maintenance Access | 5-4 |
| Power Requirements | 5-6 |
| Environmental Considerations | 5-6 |
| Unpacking the 8560 | 5-7 |
| Removing the 8560 from the Carton | 5-7 |
| Removing the Circuit Board Restrainer | 5-8 |
| Installing Options | 5-9 |
| Removing the Flexible Disk Head Restraint | 5-9 |
| Installing the Rack-Mount Guides | 5-10 |
| Selecting the Proper Primary Voltage | 5-11 |
| Installing an Additional IOP Board (8560/8561 MUSDU only) | 5-12 |
| Installing the Floating Point Option (8560 and 8561 only) | 5-12 |
| Storing and Reshipping the 8560 | 5-15 |
| Storage | 5-15 |
| Reshipment | 5-15 |

ILLUSTRATIONS

| Fig. No. | | Page |
|-------------|--|------|
| 5-1 | 8560 dimensions | 5-2 |
| 5-2 | Air flow through the 8560 MUSDU | 5-3 |
| 5-3 | Circuit board clearance requirements | 5-5 |
| 5-4 | Removing the 8560 top cover | 5-8 |
| 5-5 | Removing the 8560 circuit board restrainer | 5-9 |
| 5-6 | Rack-mount guide orientation | 5-10 |
| 5-7 | Selecting the primary power voltage range | 5-11 |
| 5-8 | Device register jumper positions | 5-12 |
| 5-9 | LSI-11/23 socket locations | 5-13 |
| 5-10 | LSI-11/73 socket locations | 5-14 |

TABLES

| Table No. | | Page |
|------------------|---|-------------|
| 5-1 | Maximum and Minimum Cable Lengths | 5-4 |
| 5-2 | Primary Power Requirements | 5-6 |

Section 5

SITE PREPARATION AND UNPACKING

INTRODUCTION

This section provides instructions on how to unpack and install an 8560 Series MUSDU. This section addresses:

- How to prepare the site, including space and power requirements
- How to unpack the 8560, including storage and reshipment instructions

The first consideration in selecting a suitable installation site is space. Two other important criteria are power requirements and environmental conditions. The following paragraphs discuss these factors.

SITE PREPARATION

Your 8560 system consists of an 8560 Series Multi-User Software Development Unit and at least one CRT terminal used as the system console. Your system may also include:

- Up to seven additional terminals
- Up to eight 8540 Integration Units or 8550 Microcomputer Development Labs. If possible, your system console should be connected directly to the 8560, not to an 8540 or 8550.
- Up to two line printers attached to your 8560, and possibly other printers attached to your 8540s or 8550s
- Other equipment, such as tape drives, modems, logic analyzers, or prototype hardware

Space Requirements

Figure 5-1 shows the 8560 MUSDU dimensions.

Here are the main considerations that apply when setting up an 8560:

- Allow adequate clearance for ventilation. See Fig. 5-2.
- Allow enough clearance at the rear of the unit to permit proper cable dress.
- Provide enough space for a system terminal and perhaps one or two line printers.
- Provide additional desk space near the system terminal for reference documents and other papers.

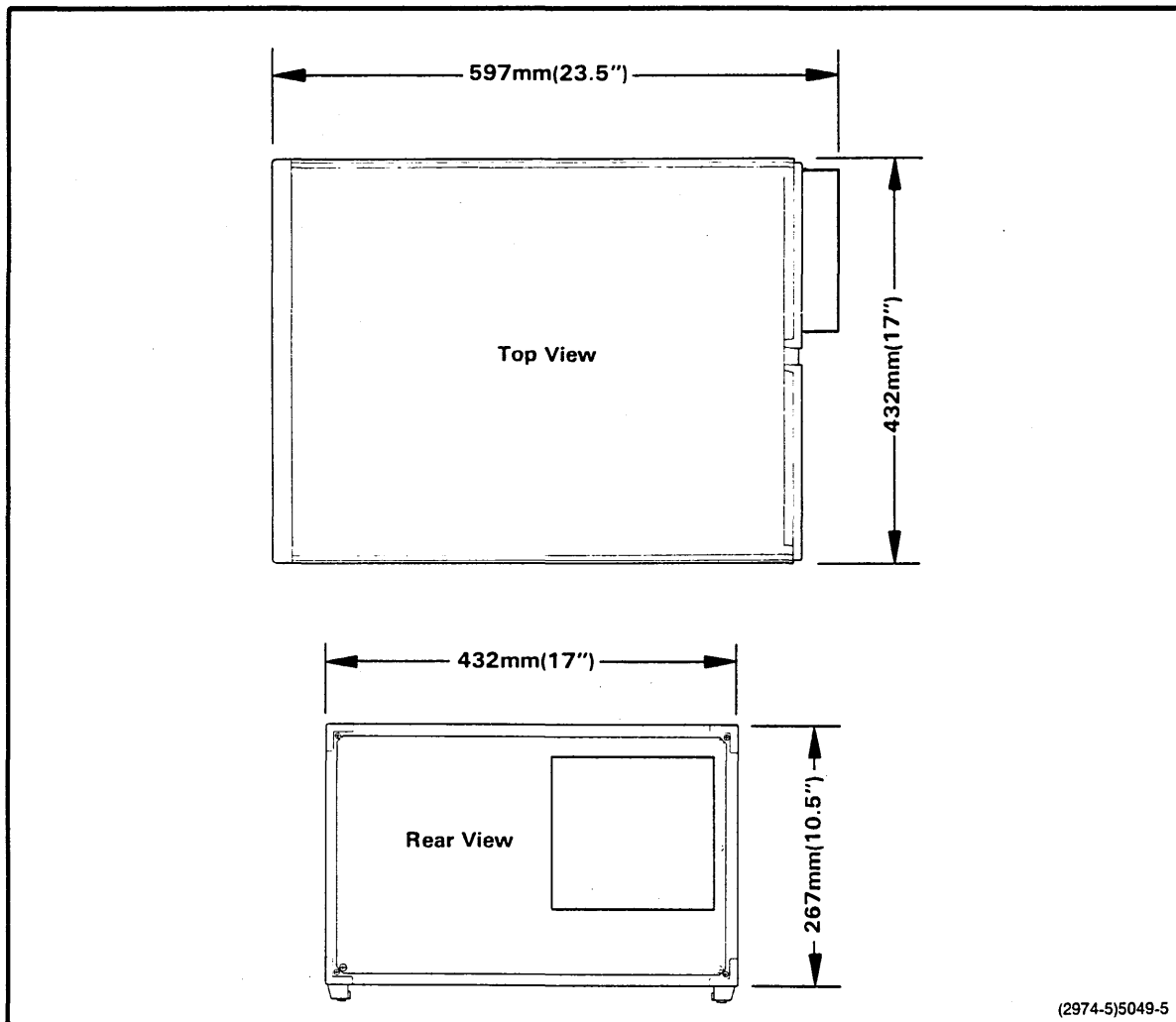

Fig. 5-1. 8560 dimensions.

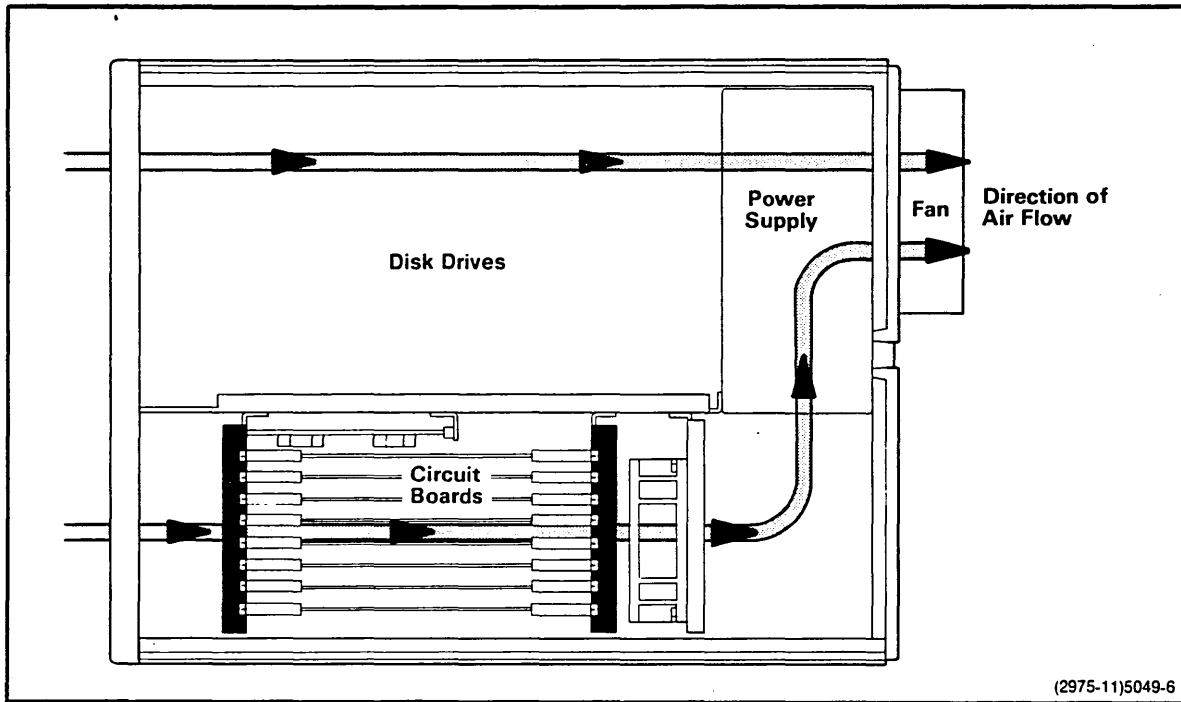

Fig. 5-2. Air flow through the 8560 MUSDU.

Cable Lengths

Table 5-1 shows typical and maximum cable lengths for your system. Longer cable lengths allow you to locate some system components away from the area where the 8560 mainframe is located.

Table 5-1
Maximum and Minimum Cable Lengths

| Peripheral | Type of Link to 8560 | Length of Cable to 8560 (ft) | | Modem Allowed? |
|--------------|----------------------|------------------------------|-------------------|------------------|
| | | Typ. | Max. ^a | |
| Terminal | RS-232-C | 5-50 | 1000 | Yes |
| Line printer | RS-232-C | 5-50 | 1000 | Yes ^b |
| 8550 | RS-232-C | 5-50 | 1000 | Yes ^c |
| 8540 | RS-422 (preferred) | 5-50 | 2000 | No |
| | RS-232-C | 5-50 | 1000 | Yes ^c |

^a Cable lengths in the "Typical" range are recommended. However, cables of up to 1000 ft (RS-232-C) or 2000 ft (RS-422) have been used successfully with 8560 systems.

^b DTR/DSR flagging is not implemented for line printers connected to modems.

^c When connected to the 8560 by way of a modem, an 8540 or 8550 can communicate with the 8560 through a COM interface, but may not be able to communicate through the preferred TERM interface. (COM software on the 8540 is available as an option.) TERM and COM interfaces are discussed in the Communication with 8540s and 8550s section of your 8560 Series System Users Manual.

Maintenance Access

To gain access to the inside of the 8560 for servicing and troubleshooting consider the following requirements:

- Allow adequate space behind the unit to permit removal of the top cover and side panels. If sufficient space behind the unit is not available, it will be necessary to turn the unit around or remove it from the installation site to remove the top cover and side panels.
- Allow adequate clearance above the 8560 to permit inspection and removal of circuit boards, as shown in Fig. 5-3.

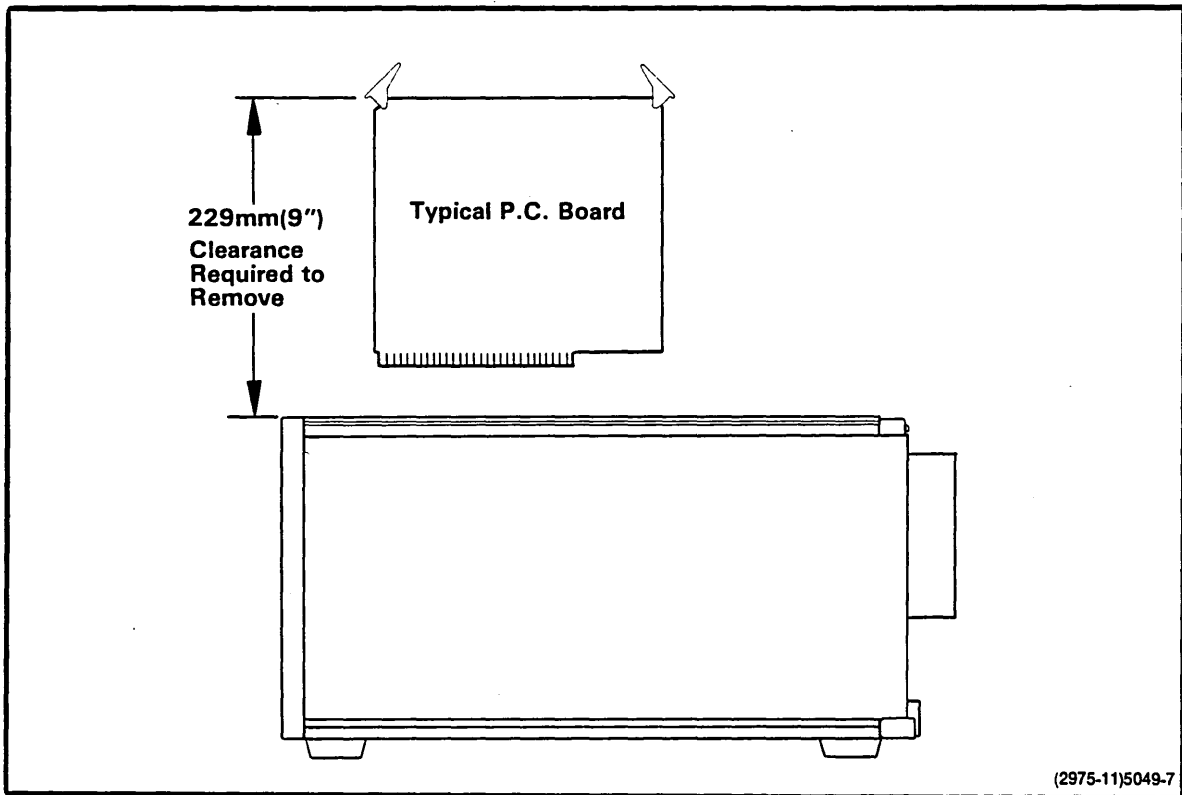

Fig. 5-3. Circuit board clearance requirements.

Power Requirements

Table 5-2 shows the primary power requirements for the 8560 Series MUSDU.

**Table 5-2
Primary Power Requirements**

| Characteristic | Description |
|---------------------|---|
| Line Voltage | 115 Vac Nominal (90–132 Vac) or 230 Vac Nominal (180–250 Vac) |
| Line Frequency | 48–66 Hz |
| Line Current Fusing | 8 Amps @ 115V 4 Amps @ 230V |
| Power Dissipation | 410 Watts (maximum) |

When preparing the site for the 8560, observe the following electrical guidelines:

- Any peripheral components installed in the area must share common ground and neutral lines to avoid noisy grounds and ground loops.
- All units must be properly grounded.
- Power for the installation site should be on a separate service circuit breaker.

Environmental Considerations

CAUTION

Static discharge may damage components of the 8560. Follow standard anti-static procedures when installing an 8560 MUSDU.

The following considerations should be taken into account when preparing the installation site:

- The area selected for the 8560 installation should be air-conditioned and dust-free.
- The area should be as static-free as possible. If carpet is used, the carpet must be static-free and treated with anti-static chemicals as often as required.
- Maintain at least 6 inches of clearance at the rear of the 8560 to allow adequate air circulation.

UNPACKING THE 8560

Before you unpack the 8560, examine the carton for external damage. If any damage is detected:

- Immediately notify the carrier who delivered the 8560, and request an inspection.
- Contact your nearest Tektronix Field Engineering Office or sales representative.
- Do not throw away any cartons or other shipping materials.
- DO NOT ATTEMPT TO REPAIR THE INSTRUMENT.



The 8560 hard-disk drive can be severely damaged by handling the 8560 too roughly. Exercise reasonable care when lifting or moving your 8560. DO NOT DROP the 8560 onto the bench top or other surface after it has been removed from its shipping carton.

Removing the 8560 from the Carton

The 8560 is packed in a heavy-duty cardboard container, surrounded by foam packing material. Inside the container, a piece of cardboard covers the top of the unit. The power cord and any options rest on this cardboard.

When you open the carton, remove the power cord and any other material that may be on the cardboard, and set these items aside. Remove the cardboard and set it aside.

A rectangular icon with a solid border containing the word "WARNING" in bold, uppercase letters.

WARNING

Be careful when lifting the 8560 out of the carton. The 8560 weighs 22 kg (49 lbs). Don't hurt yourself—get some help.

Remove the 8560 and its surrounding foam. Set the packing material aside. Don't lose this packing material—you'll need it again if you ever need to ship the 8560. After removing the 8560 from its shipping carton, set it on a flat surface, preferably the site you have selected for the installation. Examine the outside of the 8560 for any damage that may have been incurred during shipment. If damage is found, follow the procedure given under "Storage and Reshipment" later in this section.

Removing the Circuit Board Restrainer

Inside the 8560, an aluminum circuit board restrainer covers the circuit boards that are installed in the card cage. This restrainer holds the circuit boards securely in place during shipment. The following steps tell how to remove the 8560 top cover and the circuit board restrainer:

1. Remove the two plastic upper cover retainers, as shown in Fig. 5-4. Slide the cover toward the rear of the instrument and lift off.
2. Examine the inside of the 8560 for any loose circuit boards or other components, cables, or connectors. If any damage is apparent, follow procedures given earlier for reporting damage.
3. Using a Phillips screwdriver, loosen the two screws on one end (either end) of the restrainer assembly. Use extreme care not to drop the screws into the 8560. Severe electrical damage can result if these items are left inside the unit.
4. Remove the two screws on the other end of the restrainer and carefully remove the retainer clip. (See Fig. 5-5.)
5. Remove the restrainer from the 8560 card cage.
6. Reassemble the circuit board restrainer and store it with the packing materials, for use in case the unit is stored or shipped.
7. If you have optional boards to install, do not replace the top cover at this time. Check the installation information for the appropriate option. If you don't have any options, replace the cover by reversing the removal process.

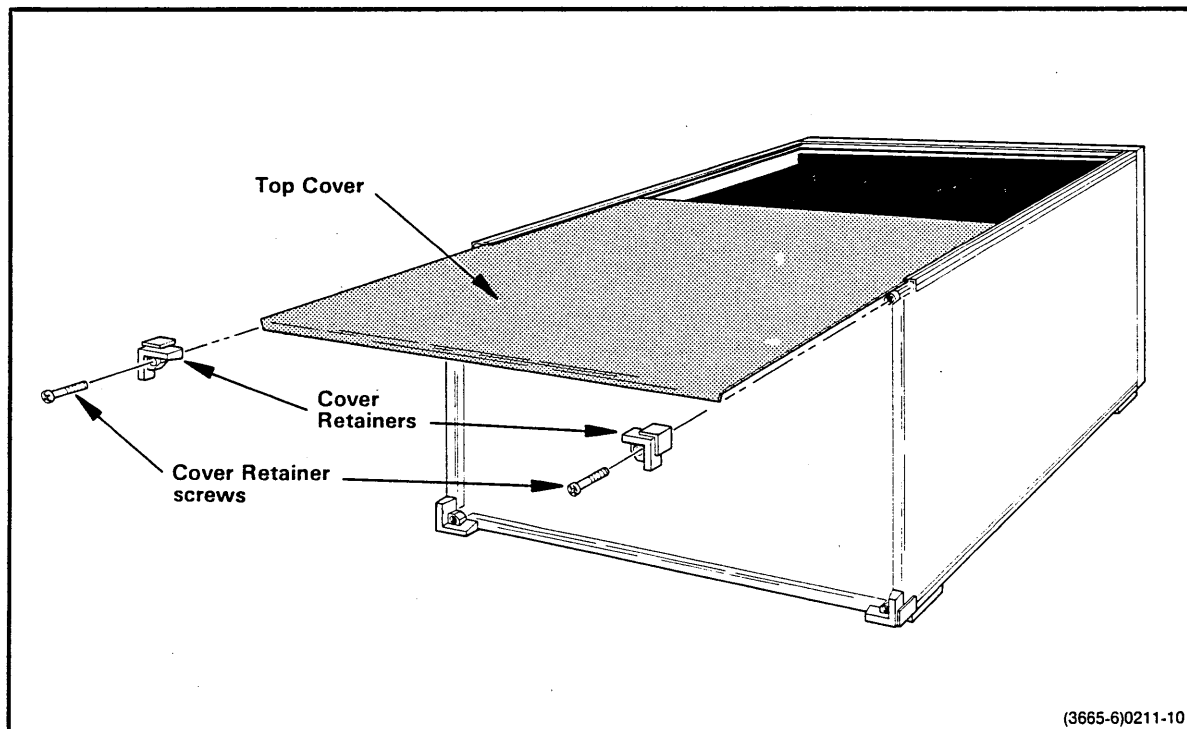

Fig. 5-4. Removing the 8560 top cover.

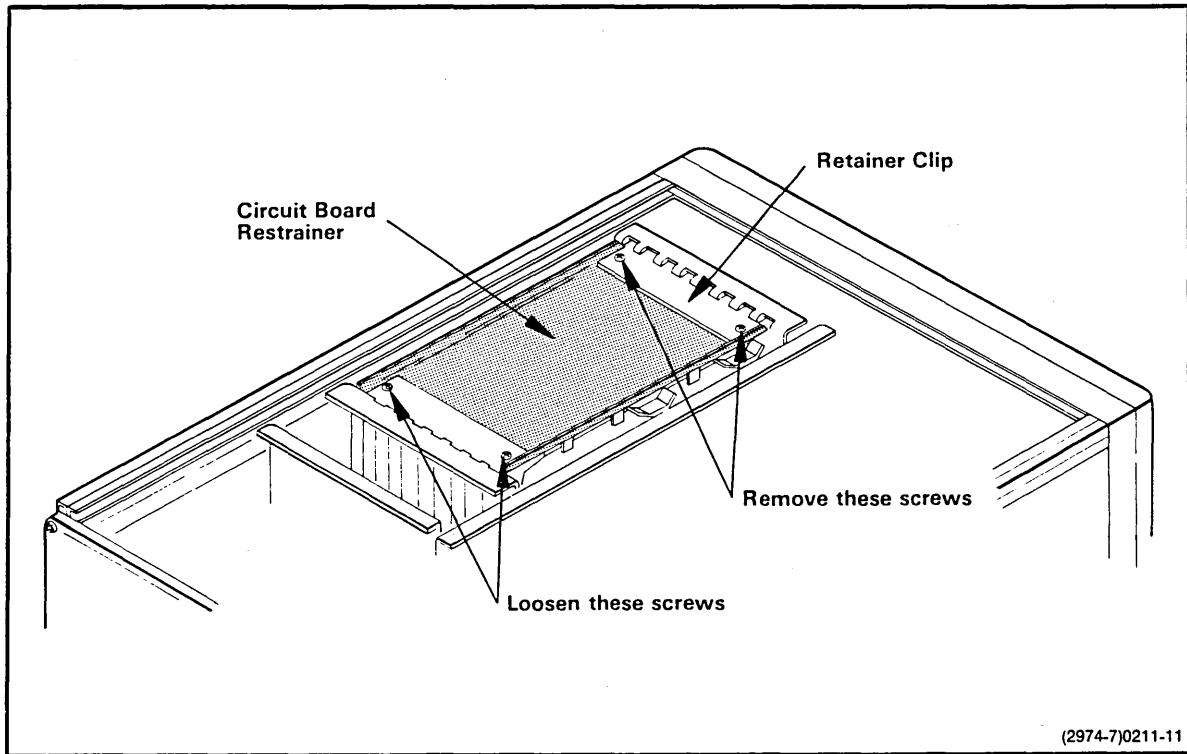

Fig. 5-5. Removing the 8560 circuit board restrainer.

Installing Options

Installation instructions for the Floating Point Option are given later in this section. Information concerning the installation of other options is provided in the Installation Manual for the specific option.

Removing the Flexible Disk Head Restraint

To prevent damage to the read/write heads in the flexible-disk drive assembly, a cardboard head restraint is installed in the disk slot during shipment or storage of the 8560 MUSDU. Before you operate the 8560, remove this restraint by pulling outward on the cardboard tab that protrudes through the front panel of the flexible-disk drive unit. Store the cardboard head restraint with the other packing materials, for use in case the unit is stored or shipped.

Installing the Rack-Mount Guides

If the 8560 includes the rack-mount option, you'll find rack-mount hardware in the bottom of the 8560 shipping container. The rack-mount slides are already mounted to the sides of the 8560. The slide guides must be installed in the equipment rack.

Figure 5-6 illustrates the guide orientation. Install the guides in the rack with the hardware provided. Tighten all screws securely. When the guides are mounted, slide the 8560 into the rack, keeping cable dress in mind.

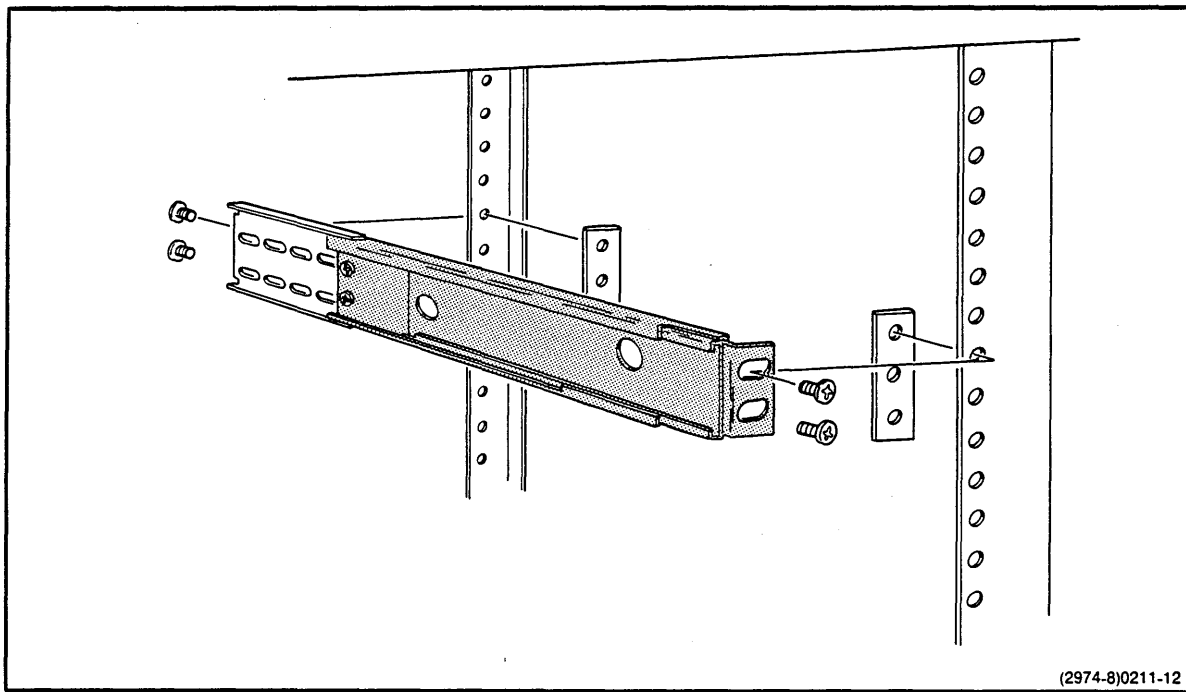

Fig. 5-6. Rack-mount guide orientation.

Selecting the Proper Primary Voltage

Each 8560 has been configured to connect to the primary power source available at its installation site. If, for any reason, you must change to a different power source, use the following procedure to adapt the 8560 to the new input power:

1. Face the rear of the unit. Notice the small plate in the lower right portion of the rear panel. Remove the screw that holds this plate, as shown in Fig. 5-7.
2. Set the power range selector switch, located under the plate, to the correct primary power range. This switch selects operation at either 115 or 230 volts (nominal), as marked.
3. Install a fuse with the proper rating into the line fuse holder.
4. Replace the switch cover plate so that the new voltage range is indicated.



You must use a fuse with the proper rating. For 115-Volt operation, use a 3AG, 8 A, 250 V, fast-blow fuse. For 230-Volt operation, use a 3AG, 4 A, 250 V, fast-blow fuse.

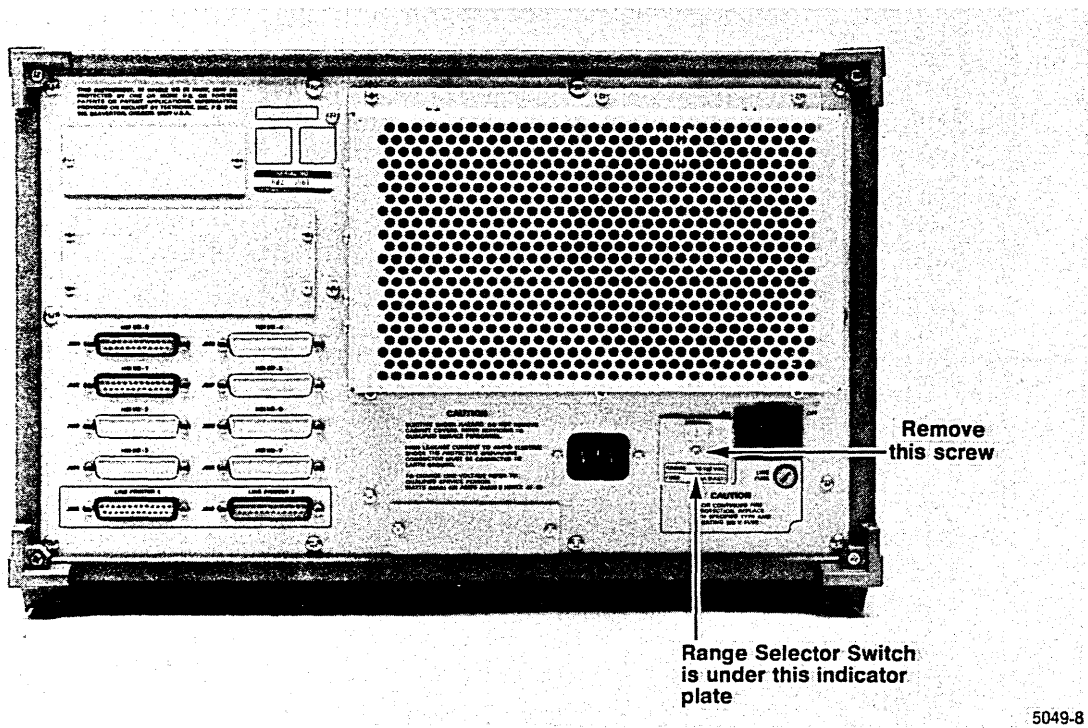

Fig. 5-7. Selecting the primary power voltage range.

Installing an Additional IOP Board (8560/8561 MUSDU only)

If you purchased a second IOP (I/O Processor) Board, it must be installed in slot J11 of the Main Interconnect Board. Factory-shipped IOP Boards are typically configured as Board 1. It is necessary to change the configuration to select Board 2 by setting the board's Device Register jumpers to their proper positions. Figure 5-8 shows the jumper positions for both IOP Boards.

Installation of the second IOP Board also requires that you reset bus grant jumpers J24 and J31 on the Main Interconnect Board to the NO PASS position. (For more information on the bus grant jumpers, refer to Section 6 of this manual.)

Installing the Floating Point Option (8560 and 8561 only)

NOTE

The floating point arithmetic capability is a standard feature with the LSI-11/73.

The Floating Point Option is part of the LSI-11/23 integrated circuit set that enables the 8560 or 8561 to perform floating point arithmetic. This option consists of an integrated circuit device that plugs into an assigned socket on the LSI-11/23 Board. Figure 5-9 shows the socket location, and identifies pin 1. Install the Floating Point Option as follows:

CAUTION

To prevent damage to the floating point device, you must be in a static-free environment.

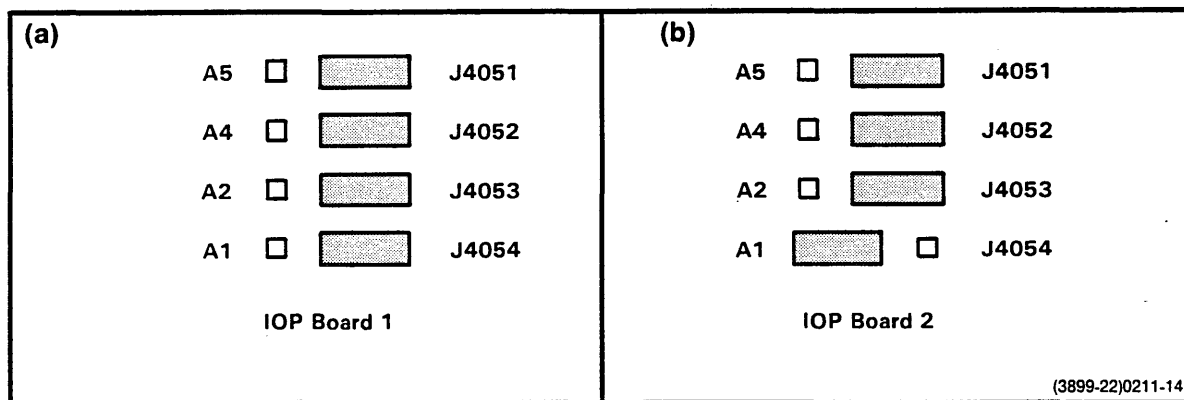
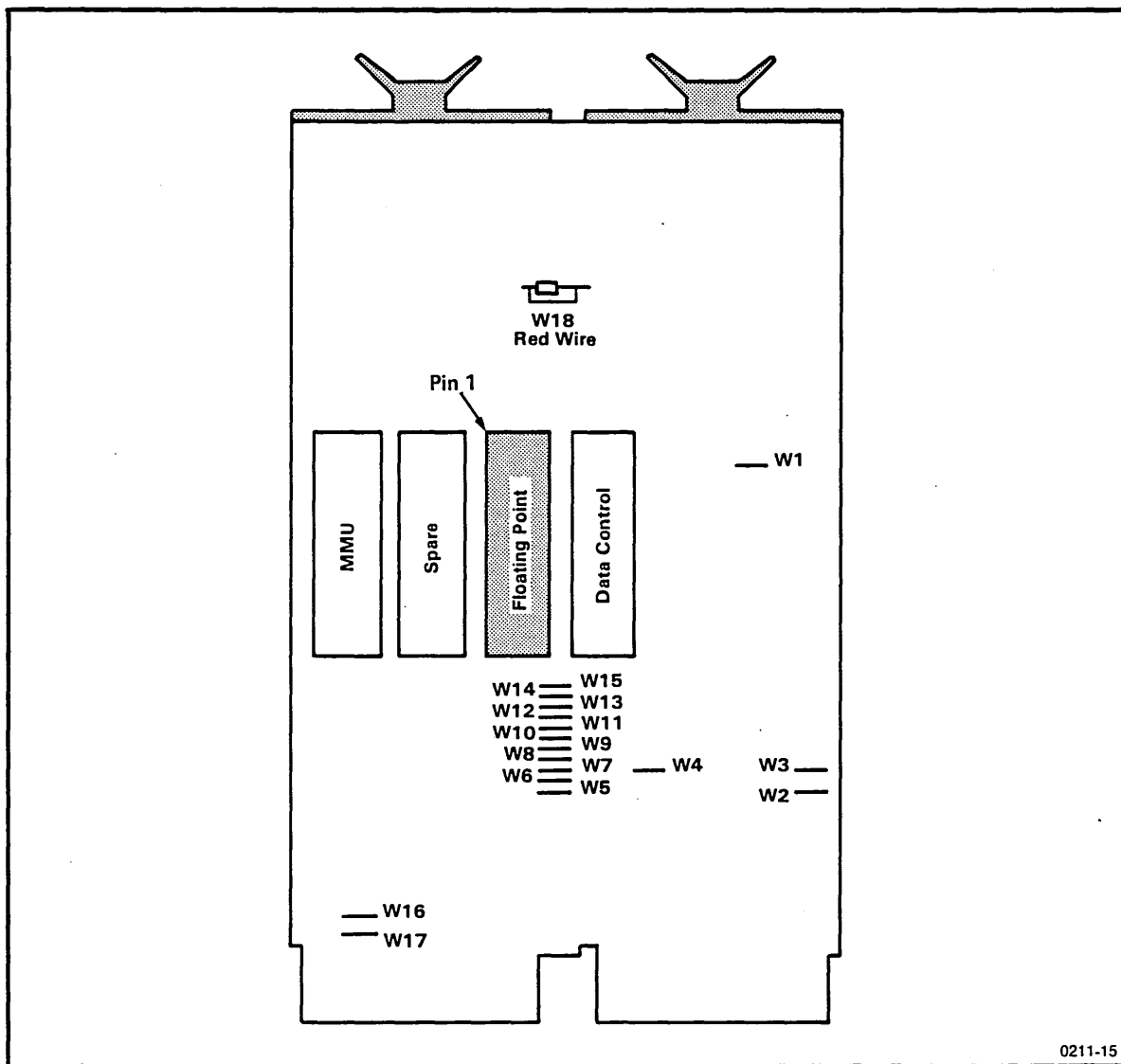

Fig. 5-8. Device register jumper positions.

1. Remove the 8560 cabinet cover.
2. Remove the LSI-11/23 Board.
3. Locate the floating point socket. (See Fig. 5-9.)
4. Carefully remove the floating point integrated circuit device from its static-free packaging material and install it in the proper socket. The device is particularly susceptible to static discharge during this step.
5. Replace the LSI-11/23 Board and the top cover.



0211-15

Fig. 5-9. LSI-11/23 socket locations.

As noted above, the floating point arithmetic capability is a standard feature of the LSI-11/73. Figure 5-10 shows the socket location.

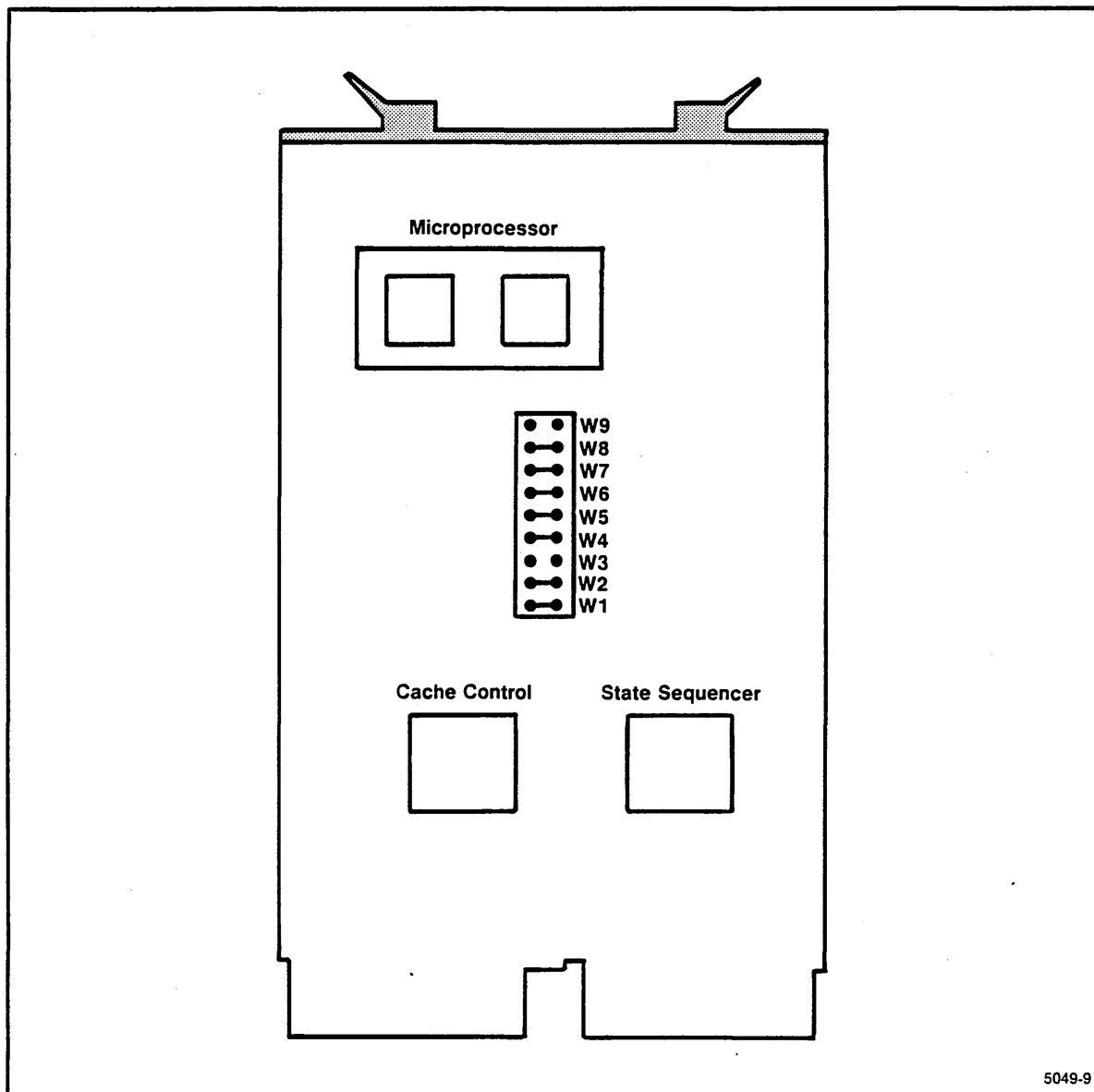

Fig. 5-10. LSI-11/73 socket locations.

STORING AND RESHIPPING THE 8560

When a precision electronic instrument such as the 8560 is placed in storage or reshipped, it's best to repack it as it was originally shipped from the factory. For this reason, you should save the carton and packing material in which your 8560 was shipped. To repack the 8560, simply reverse the unpacking instructions, as described earlier in this section. Be sure to reinstall the circuit board restrainer and the cardboard head restraint in the flexible disk drive. Other considerations for 8560 storage or reshipment are given in the following paragraphs.

NOTE

We strongly recommend that you back up your system before storing or reshipping the 8560. Backup procedures are provided in Section 1 of this manual.

Storage

Observe the following considerations whenever you place the 8560 in storage:

- Provide adequate protection from dust.
- Do not exceed the humidity or temperature limitations of the instrument. (These limitations are listed in the Specifications, in Appendix A of this manual.)
- Store the carton upright. Do not compress the carton or stack heavy objects on top of it.

Reshipment

If the 8560 must be shipped to the factory or service center, the following steps should be taken:

- Note the serial number of the unit on the back panel and any other relevant numbers or symbols needed for identification. (This information is required for any related correspondence, which should be sent separately.)
- Wrap the unit in durable waterproof material such as heavy polyethylene, and tape securely. This step should be performed only in a dry atmosphere, and only when the unit is cool to the touch.
- Pack the unit in a sturdy box (heavy cardboard is acceptable for land shipment), lined with 76 mm (3 inches) of medium density foam or expanded polystyrene.
- Cables, adapters, and other accessories should be wrapped separately and attached by tape to the inner liner at a break in the foam, or taped to a separate platform mounted above the foam or polystyrene (as used in the original shipping package). In the latter case, a sheet of 25 mm (1 in) minimum thick foam should be taped above the cable package.
- Seal the carton with reinforced packaging tape and identify the sender, the unit number, and the serial number on the outside of the carton.
- Notify the factory or your sales representative of your intent to ship the instrument, and await their acknowledgment before you actually ship your 8560.

Section 6

8560 BOARD CONFIGURATION

| | Page |
|---|------|
| Introduction | 6-1 |
| Jumpers and Straps | 6-1 |
| Jumpers | 6-1 |
| Straps | 6-2 |
| LSI-11/23 Processor | 6-2 |
| LSI-11/73 Processor | 6-3 |
| 256K and 512K Memory Boards | 6-4 |
| Memory Bank Selection | 6-4 |
| I/O Memory Selection | 6-4 |
| RAM Test Jumpers | 6-6 |
| I/O Memory | 6-7 |
| MSC Board | 6-8 |
| Xebec S1410 Disk Controller | 6-9 |
| QumeTrak 242 Flexible Disk Drive | 6-10 |
| Seagate ST419 Hard Disk Drive | 6-11 |
| Micropolis 1304 Hard Disk Drive | 6-12 |
| Utility Board | 6-13 |
| Baud Rate Selection | 6-14 |
| Debug ROM Control Jumper | 6-14 |
| Strap Configuration | 6-14 |
| I/O Processor Board | 6-15 |
| Device Registers | 6-16 |
| Interrupt Vectors | 6-16 |
| I/O Boards | 6-17 |
| I/O Adapter Board | 6-17 |
| I/O Connector Board | 6-18 |
| Main Interconnect Board | 6-18 |
| Power Supply Board Configurations | 6-20 |

ILLUSTRATIONS

| Fig No | | Page |
|-----------|---|------|
| 6-1 | Jumper configuration for the LSI-11/23 Processor Board | 6-2 |
| 6-2 | Jumper configuration for the LSI-11/73 Processor Board | 6-3 |
| 6-3 | Jumper locations for 256K Memory Boards..... | 6-5 |
| 6-4 | Jumper locations for 512K Memory Boards..... | 6-6 |
| 6-5 | Jumper locations for mixed 256K and 512K Memory Boards | 6-7 |
| 6-6 | MSC Board jumper locations | 6-8 |
| 6-7 | Xebec S1410 Disk Controller jumper/strap locations..... | 6-9 |
| 6-8 | Flexible Disk Drive QumeTrak 242 jumper/strap locations | 6-10 |
| 6-9 | Seagate ST419 Hard Disk Drive Programmable Shunt | 6-11 |
| 6-10 | Micropolis 1304 Hard Disk Drive jumper locations..... | 6-12 |
| 6-11 | Utility Board jumper and strap locations | 6-13 |
| 6-12 | I/O Processor Board jumper locations | 6-15 |
| 6-13 | Device Register jumper positions | 6-16 |
| 6-14 | Interrupt priority jumpers..... | 6-17 |
| 6-15 | I/O Adapter Board Jumper configurations for interrupt priority levels | 6-17 |
| 6-16 | Location of jumpers on the I/O Adapter Board | 6-18 |
| 6-17 | Main Interconnect Board jumper locations..... | 6-19 |
| 6-18 | Secondary Board jumper locations..... | 6-21 |
| 6-19 | Regulator Board jumper locations | 6-22 |

TABLES

| Table No | | Page |
|-------------|--------------------------------------|------|
| 6-1 | Baud Rate Selection | 6-14 |
| 6-2 | Interrupt Priority Assignments | 6-16 |
| 6-3 | Bus Grant Jumpers..... | 6-20 |
| 6-4 | Secondary Board Jumpers | 6-20 |
| 6-5 | Regulator Board Jumpers..... | 6-20 |

Section 6

8560 BOARD CONFIGURATION

INTRODUCTION

This section provides information about the various jumpers and straps located on circuit boards in the 8560. Only those jumpers and straps that specifically relate to installation or verification of the 8560 are discussed in detail. Other jumpers and straps are used primarily for testing, and are described in detail in the optional *8560/8561/8562 Multi-User Software Development Unit Service Manual*.

JUMPERS AND STRAPS

Standard circuit boards for the 8560 are configured for specified operating characteristics with certain jumpers and straps. The following paragraphs describe these jumpers and straps, and tell how to configure them to select the desired circuit functions.

NOTE

All jumpers and straps on 8560 circuit boards are set at the factory for proper operating configuration. However, before applying power to the 8560, you should check the circuit boards to verify that jumpers are correctly installed.

Jumpers

A jumper consists of a set of jumper pins on a circuit board, and a jumper block. A jumper block normally bridges two adjacent square pins on the circuit board. In certain applications, a larger jumper block may be used to configure several sets of jumper pins simultaneously.

- A single-position jumper station consists of only two pins. The jumper block is either installed or removed.
- A multi-position jumper station is made up of three or more pins, arranged so that the jumper block may be installed in any of two or more positions or may be removed.

Jumpers are identified with either "P" or "J" reference numbers.

Straps

A strap is a wire or a specially designed circuit board run that connects one through-hole or circuit point on a circuit board with another through-hole or circuit point. Certain circuit board runs are designed to be cut, in conjunction with strapping options, to achieve a desired configuration. These are referred to as "cuttable runs".

Straps are identified with "W" reference numbers.

LSI-11/23 PROCESSOR

There are no user-definable jumpers, straps, or switches on the LSI-11/23 Processor Board. To verify correct jumper configuration on this board, refer to Fig. 6-1.

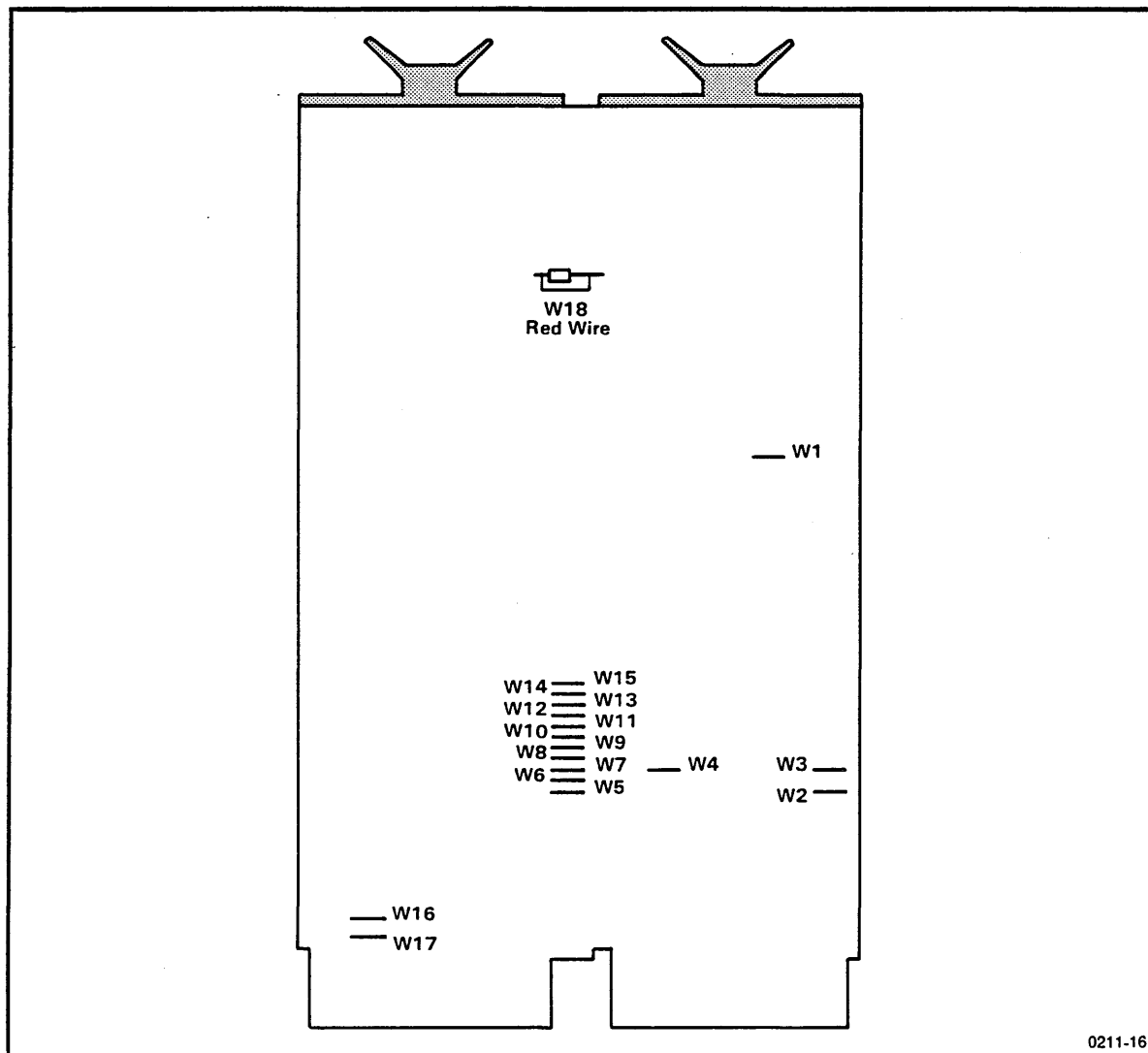

Fig. 6-1. Jumper configuration for the LSI-11/23 Processor Board.

LSI-11/73 PROCESSOR

There are no user-definable jumpers, straps, or switches on the LSI-11/73 Processor Board. To verify correct jumper configurations on this board, refer to Fig. 6-2.

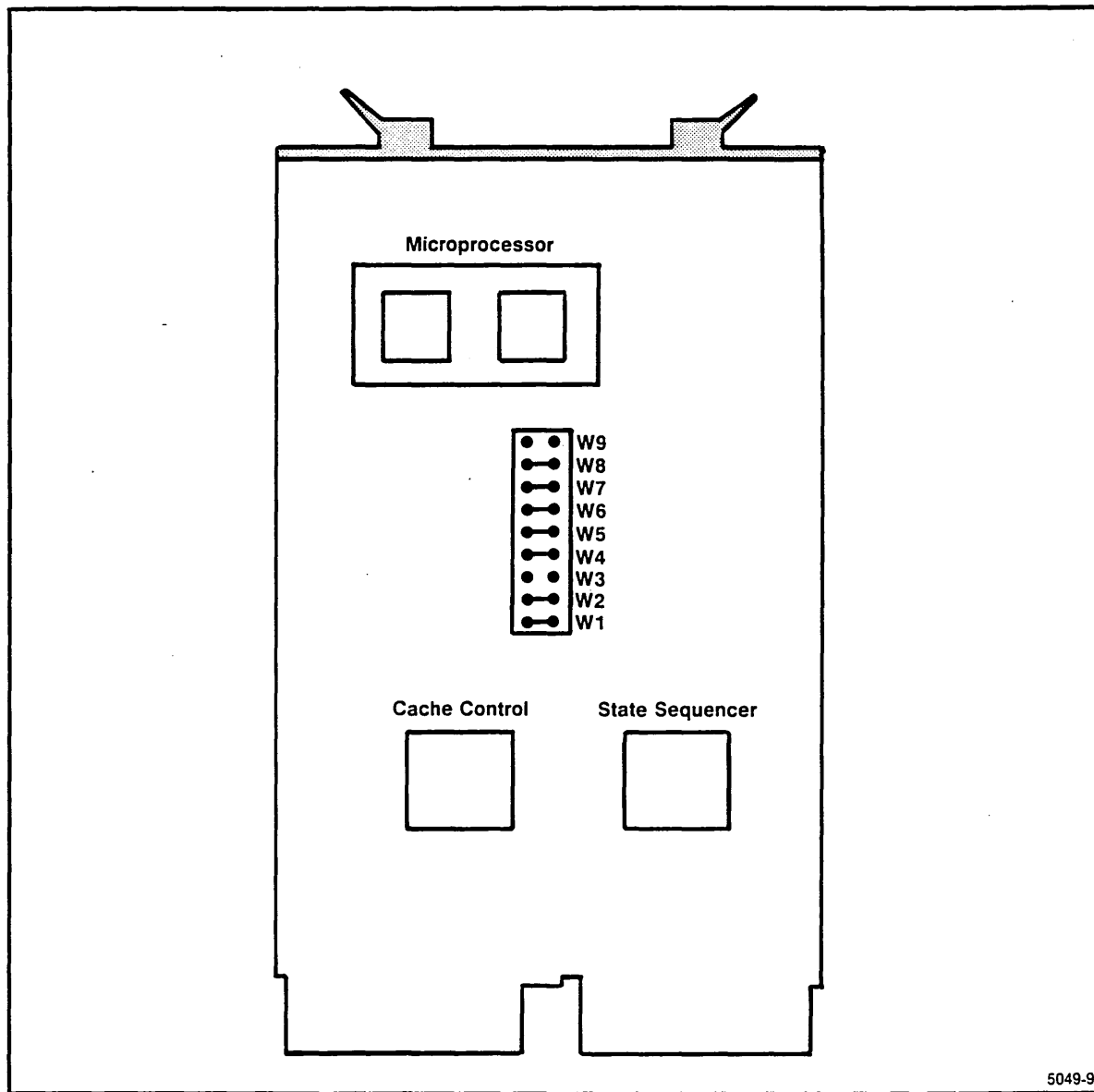

Fig. 6-2. Jumper configuration for the LSI-11/73 Processor Board.

5049-9

256K AND 512K MEMORY BOARDS

The system memory in the 8560 consists of one or two boards utilizing dynamic RAMs. Any combination of 256K and 512K Memory Boards may be used.

Memory Bank Selection

Low Bank

If only one memory board is installed, the board must be assigned to control the low bank of memory addresses. If two memory boards are used, one board must be configured as the low-bank board.

NOTE

When the 256K and 512K Memory Boards are used together, (768K-byte memory system), the 512K Memory Board must be configured as the low bank and the 256K Memory Board must be configured as the high bank.

Refer to Fig. 6-3 for low-bank configuration on the 256K Memory Board (one or two 256K Memory Boards installed). Refer to Fig. 6-4 for low-bank configuration on the 512K Memory Board (one or two 512K Memory Boards installed). Refer to Fig. 6-5 for low-bank configuration on the 512K Memory Board (256K Memory Board and 512K Memory Board installed).

In this low-bank configuration, jumper P7071(1) must be in the A-B position, jumper P7071(2) must be in the D-F position, and jumper P5173 (256K Memory Board only) must be in the W-X position.

High Bank

If two memory boards are used, one board must be configured as the high-bank board. Refer to Fig. 6-3 for high-bank configuration on the 256K Memory Board (two 256K Memory Boards installed). Refer to Fig. 6-4 for high-bank configuration on the 512K Memory Board (two 512K Memory Boards installed). Refer to Fig. 6-5 for high-bank configuration on the 256K Memory Board (256K Memory Board and 512K Memory Board installed).

I/O Memory Selection

If only one memory board is installed (low-bank operation), jumper P7072 must be in the I-G position. This enables the lower half of the highest 8K of memory for I/O operations. (Refer to Figs. 6-3 and 6-4 for low-bank configurations.)

If two memory boards are installed, I/O memory must be enabled on the high-bank board and disabled on the low-bank board. On the low-bank board, jumper P7072 must be in position G-H; on the high-bank board, jumper P7072 must be in position I-G. (Refer to Figs. 6-3, 6-4, and 6-5 for jumper configurations.)

CAUTION

Jumper P7072 must be properly installed for the 8560's TNIX operating system to function correctly.

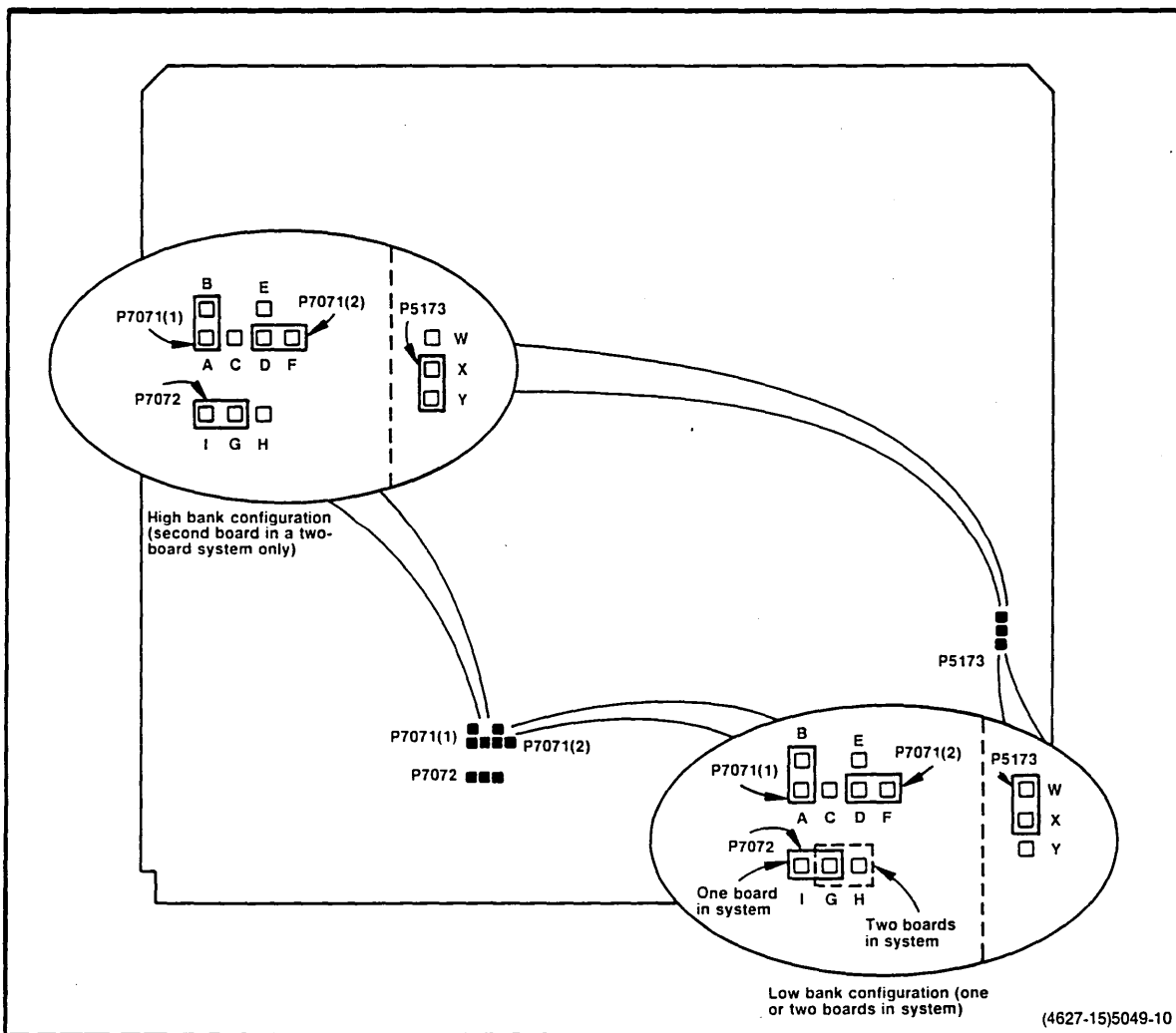

Fig. 6-3. Jumper locations for 256K Memory Boards.

RAM Test Jumpers

With the exception of P7071(1), P7071(2), P7072, and P5173 (256K Memory Board only), all jumpers on the memory boards are preset at the factory for normal operation and should not be changed. These jumpers are for test purposes only. Figures 6-3, 6-4, and 6-5 may be used to verify proper placement of the test jumpers.

There are two user-definable jumpers (P7071(1) and P7071(2)) and six user-definable straps (W7061, W7063, W7065, W7067, W7679 and W8062) for address decoding.

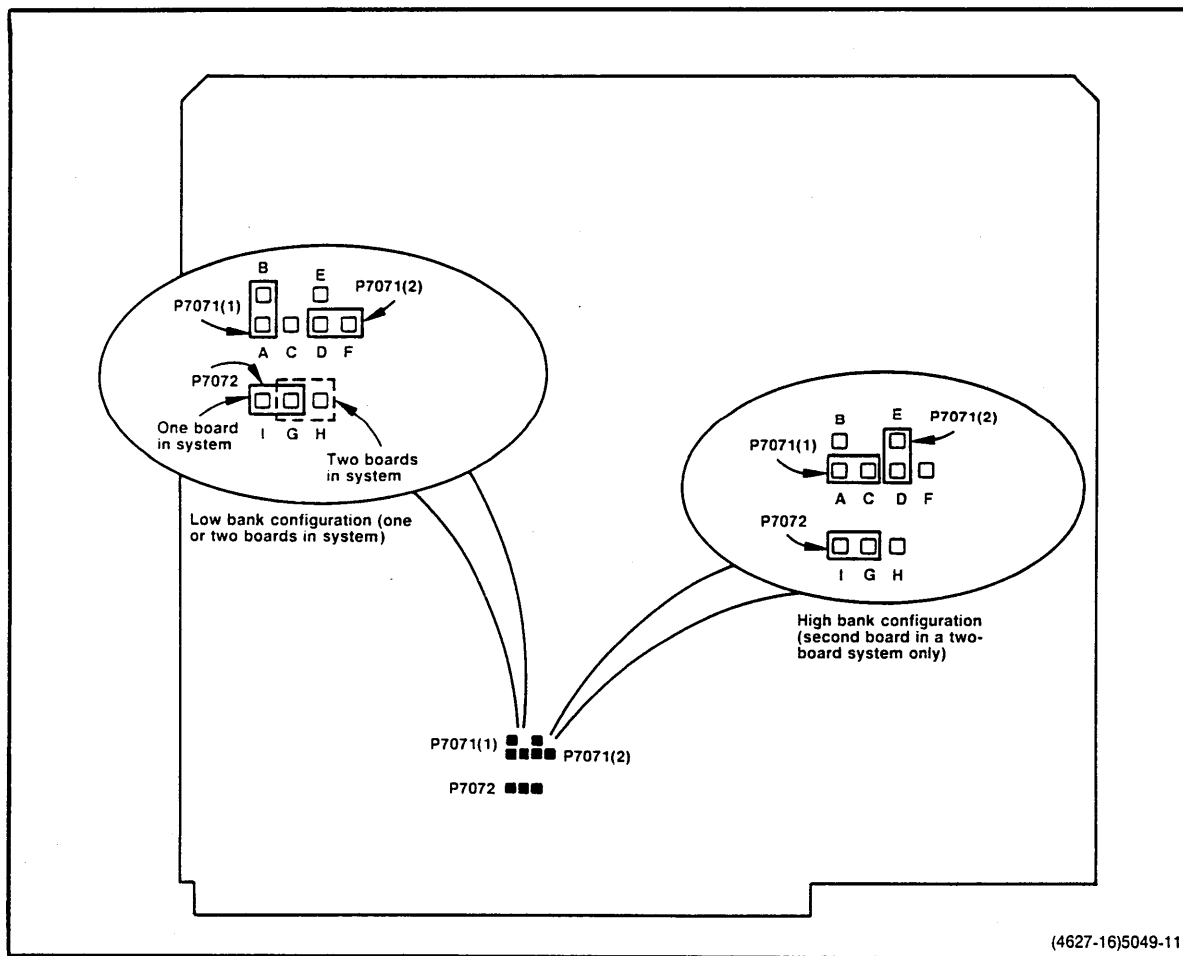

Fig. 6-4. Jumper locations for 512K Memory Boards.

I/O Memory

Jumper P7072 must be installed across pins CF-CG on the 256K/512K Memory Boards. With the jumper installed at this location, 2K of the upper portion of memory is assigned to I/O operations.

CAUTION

Jumper P7072 must be properly installed for the 8560's TNIX operating system to operate correctly.

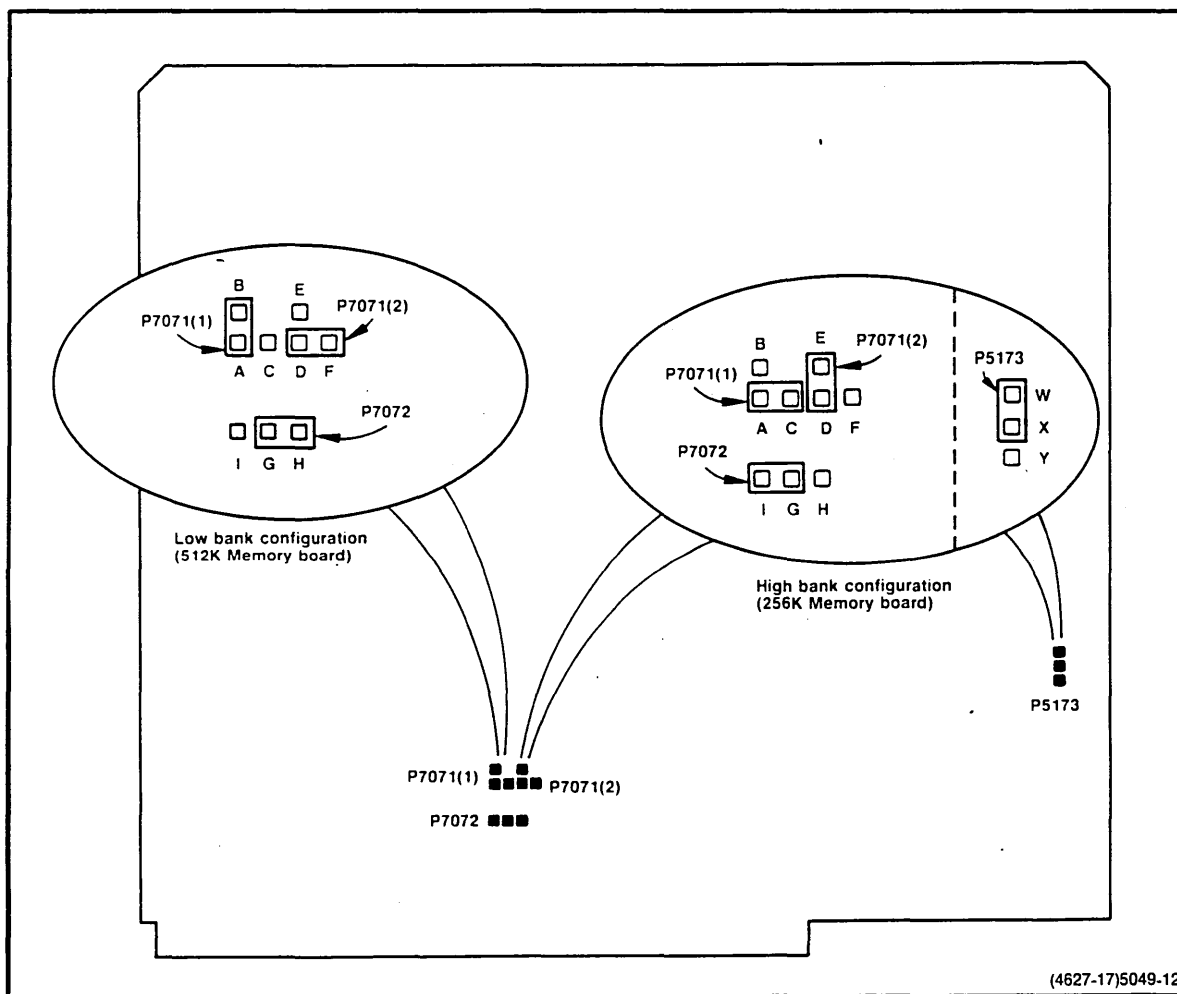

Fig. 6-5. Jumper locations for mixed 256K and 512K Memory Boards.

MSC BOARD

There are seven factory-installed jumpers on the Mass Storage Controller (MSC) Board provided for diagnostic purposes only. All jumpers are preset at the factory and should not be changed from their preset positions. Refer to Fig. 6-6 for MSC Board jumper locations.

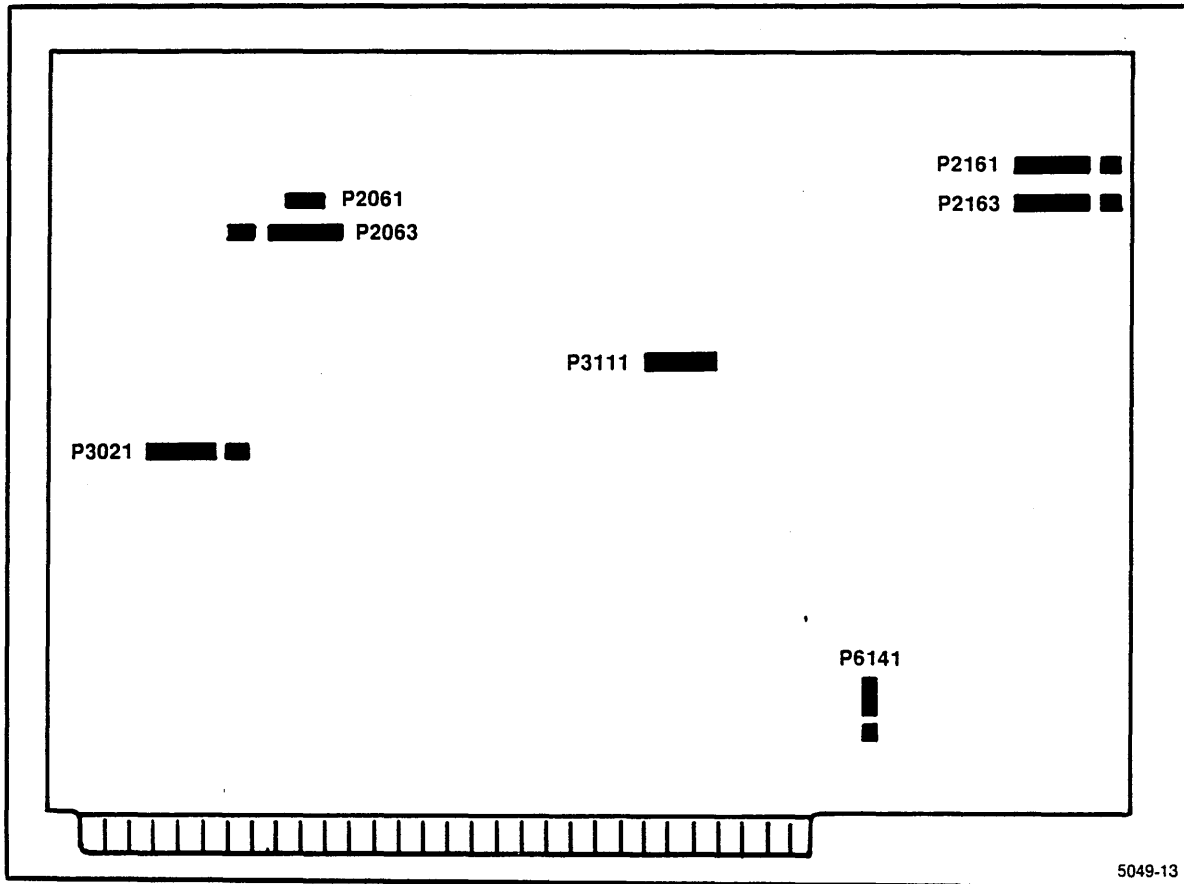

Fig. 6-6. MSC Board jumper locations.

XEBEC S1410 DISK CONTROLLER

All jumpers on the Xebec S1410 Disk Controller Board are preset at the factory for normal operation and should not be changed. Figure 6-7 shows normal jumper configuration for the Xebec S1410 Disk Controller.

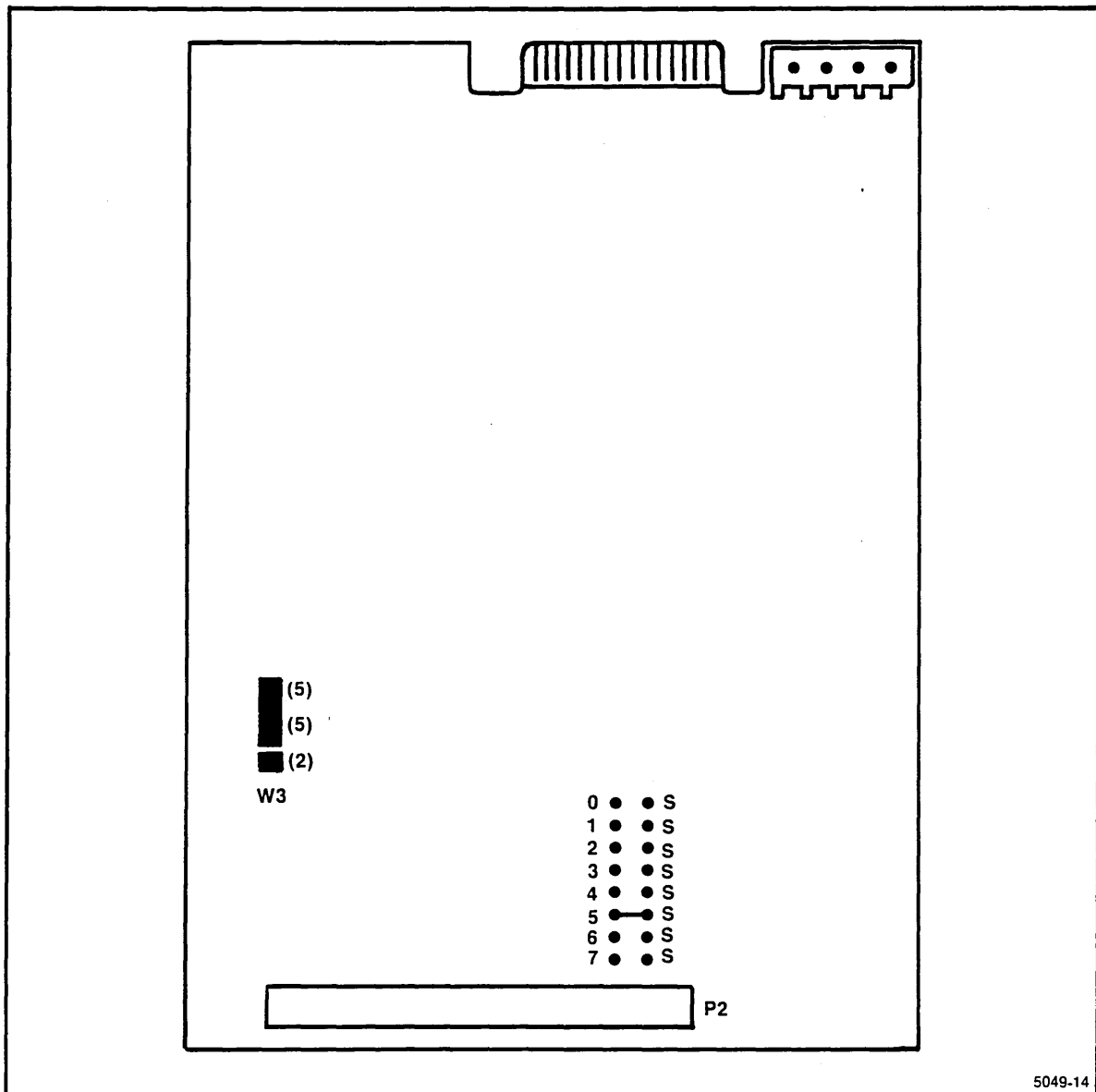

Fig. 6-7. Xebec S1410 Disk Controller jumper/strap locations.

QUMETRAK 242 FLEXIBLE DISK DRIVE

All jumpers on the QumeTrak 242 Flexible Disk Drive are preset at the factory for normal operation and should not be changed. Figure 6-8 shows normal strapping and jumpering of the QumeTrak 242 main PCB board. Trace B and Z of the programmable shunt have been cut. Optional jumper pins C, DC, 2S and Y have been added. (Refer to the QumeTrak 242 Maintenance Manual for a detailed description of programmable shunt options.)

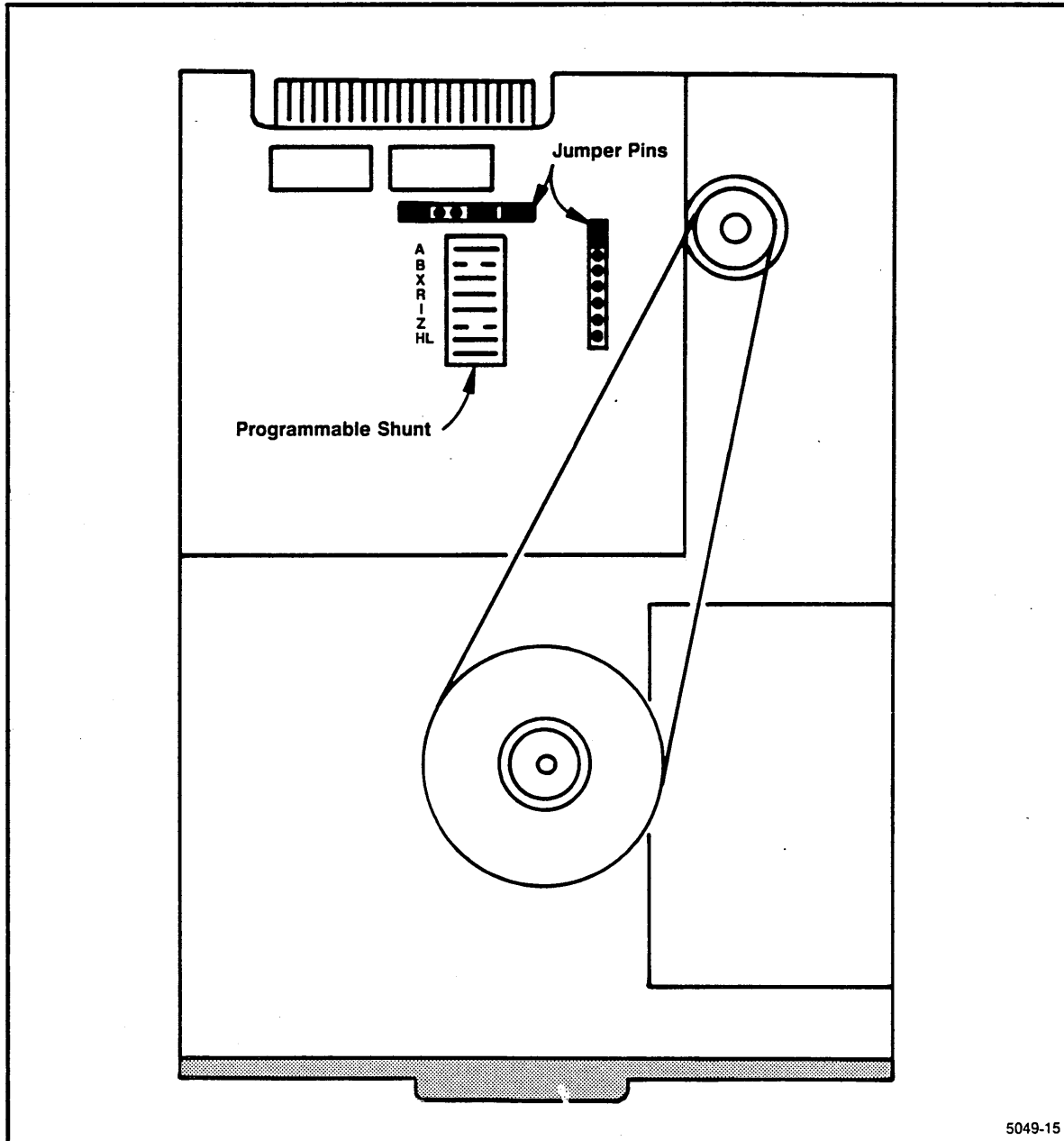

Fig. 6-8. Flexible Disk Drive QumeTrak 242 jumper/strap locations.

SEAGATE ST419 HARD DISK DRIVE

The programming shunt for the Seagate ST419 Hard Disk Drive is a 14-pin shunt in a 16-pin socket, located on Main Control PCB 20096 of the Seagate ST419 Hard Disk Drive. Pins 1 and 16 of the socket are not used; the shunts are cut between pins 7 and 10, 6 and 11, and 5 and 12. (Refer to the *Seagate ST406/412/419 Microwinchester Service Manual* for a detailed description of the programmable shunt options.) The shunt selects drive 1. Figure 6-9 shows the programmable shunt for the Seagate ST419 Hard Disk Drive.

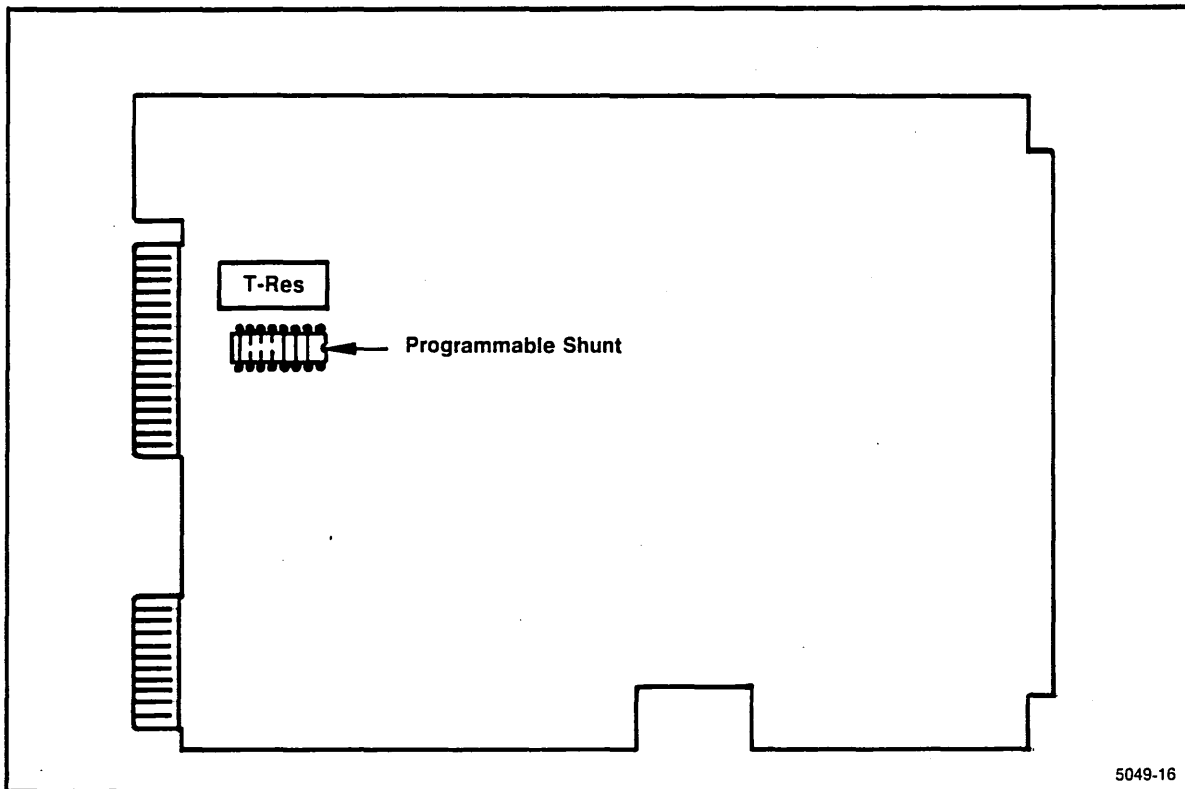

Fig. 6-9. Seagate ST419 Hard Disk Drive Programmable Shunt.

MICROPOLIS 1304 HARD DISK DRIVE

The drive select for the Micropolis 1304 Hard Disk Drive is a movable, factory-installed jumper on the drive's Device Electronics Board. The jumper selects drive 1. (Refer to the *1300 Series Rigid Disk Drive Maintenance Manual* for more information about drive selection.) Figure 6-10 shows the default jumpering of the Micropolis 1304 Hard Disk Drive.

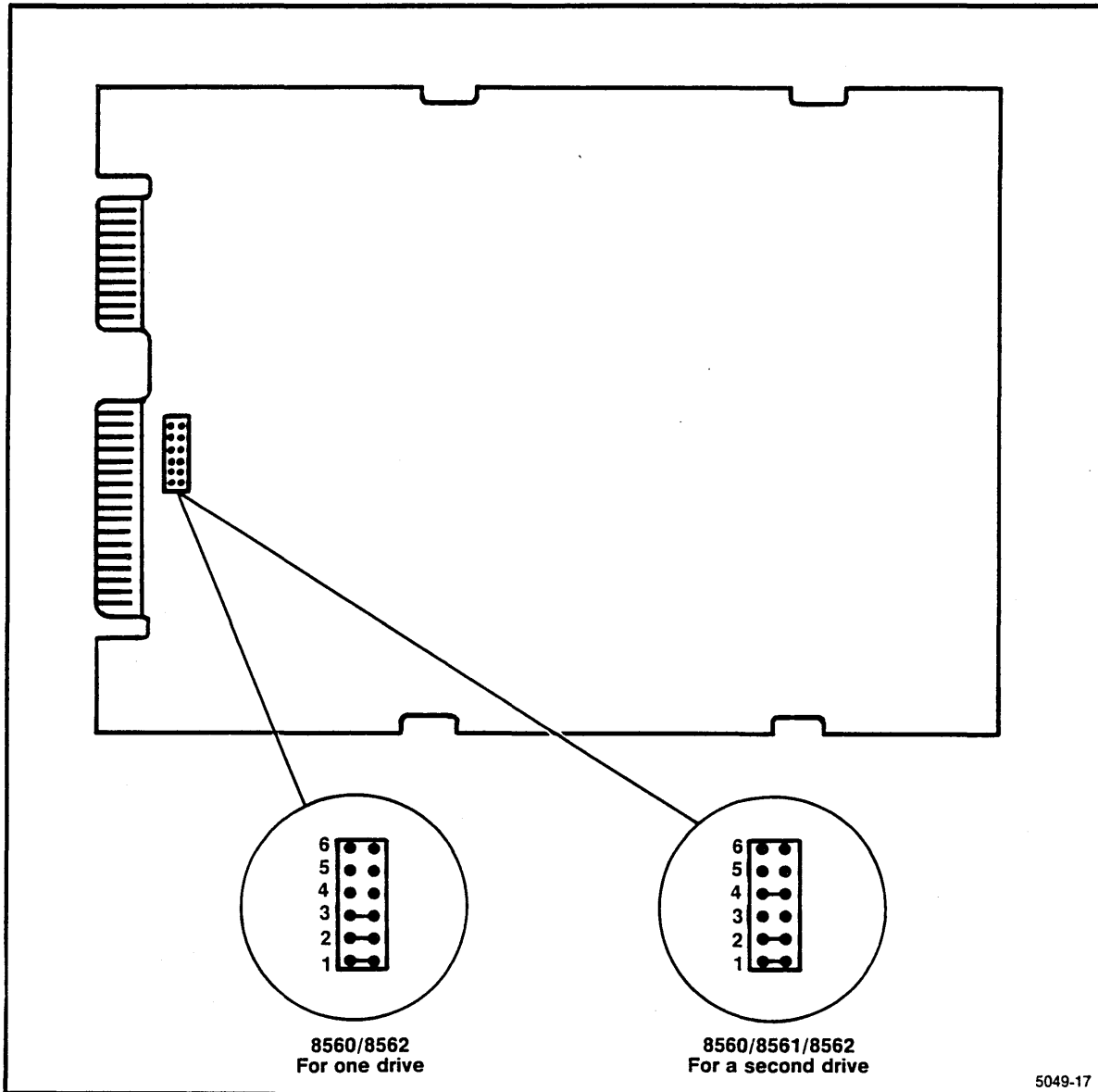

Fig. 6-10. Micropolis 1304 Hard Disk Drive jumper locations.

UTILITY BOARD

Figure 6-11 shows the location of jumpers and straps on the Utility Board.

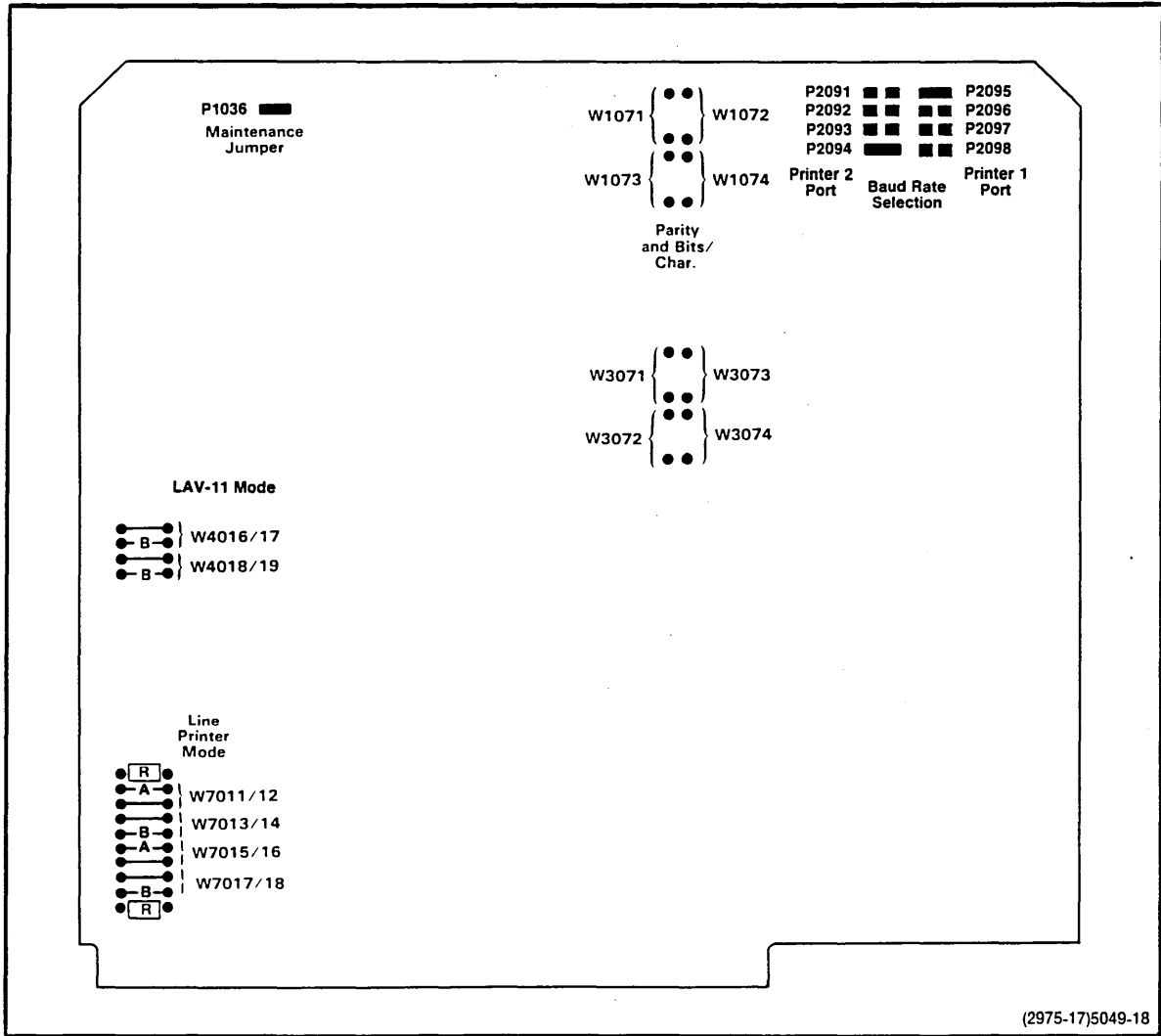

Fig. 6-11. Utility Board jumper and strap locations.

Baud Rate Selection

The baud rate for the two dedicated RS-232-C line printer interfaces is factory set at 2400 baud. If a different baud rate is required, strapping options on the Utility Board permit you to select a specific baud rate. The Utility Board can also be configured to accept an external TTL-level clock signal between 0 and 320 kHz. (The external clock frequency is 16 times the baud rate.) Table 6-1 lists the strapping options for baud rate selection.

Table 6-1
Baud Rate Selection

| Interface 1 Jumpers—P2095 | | P2096 | P2097 | P2098 | Baud Rate |
|---------------------------|-----|-------|-------|-------|------------|
| Interface 2 Jumpers—P2094 | | P2093 | P2092 | P2091 | |
| | In | In | In | In | Ext. Clock |
| | In | In | In | Out | Ext. Clock |
| | In | In | Out | In | 50 |
| | In | In | Out | Out | 75 |
| | In | Out | In | In | 134.5 |
| | In | Out | In | Out | 200 |
| | In | Out | Out | In | 600 |
| | In | Out | Out | Out | 2400 |
| | Out | In | In | In | 9600 |
| | Out | In | In | Out | 4800 |
| | Out | In | Out | In | 1800 |
| | Out | In | Out | Out | 1200 |
| | Out | Out | In | In | 2400 |
| | Out | Out | In | Out | 300 |
| | Out | Out | Out | In | 150 |
| | Out | Out | Out | Out | 110 |

Debug ROM Control Jumper

For normal system operation, jumper P1036 must be installed.

Strap Configuration

All straps on the Utility Board are preset at the factory for normal system operation and should not be altered. For information about these straps and alternate configurations, contact your Tektronix field service representative.

I/O PROCESSOR BOARD

The interface circuitry in the 8560 includes one or two I/O Processor (IOP) Boards. One of these boards controls I/O functions through HSI I/O Ports 0 through 3, and the second board controls HSI I/O Ports 4 through 7. Figure 6-12 shows the jumpers on the IOP Board positioned for normal operation. Except for the jumpers discussed in the following paragraphs, jumpers on the IOP Board are preset at the factory and should not be changed.

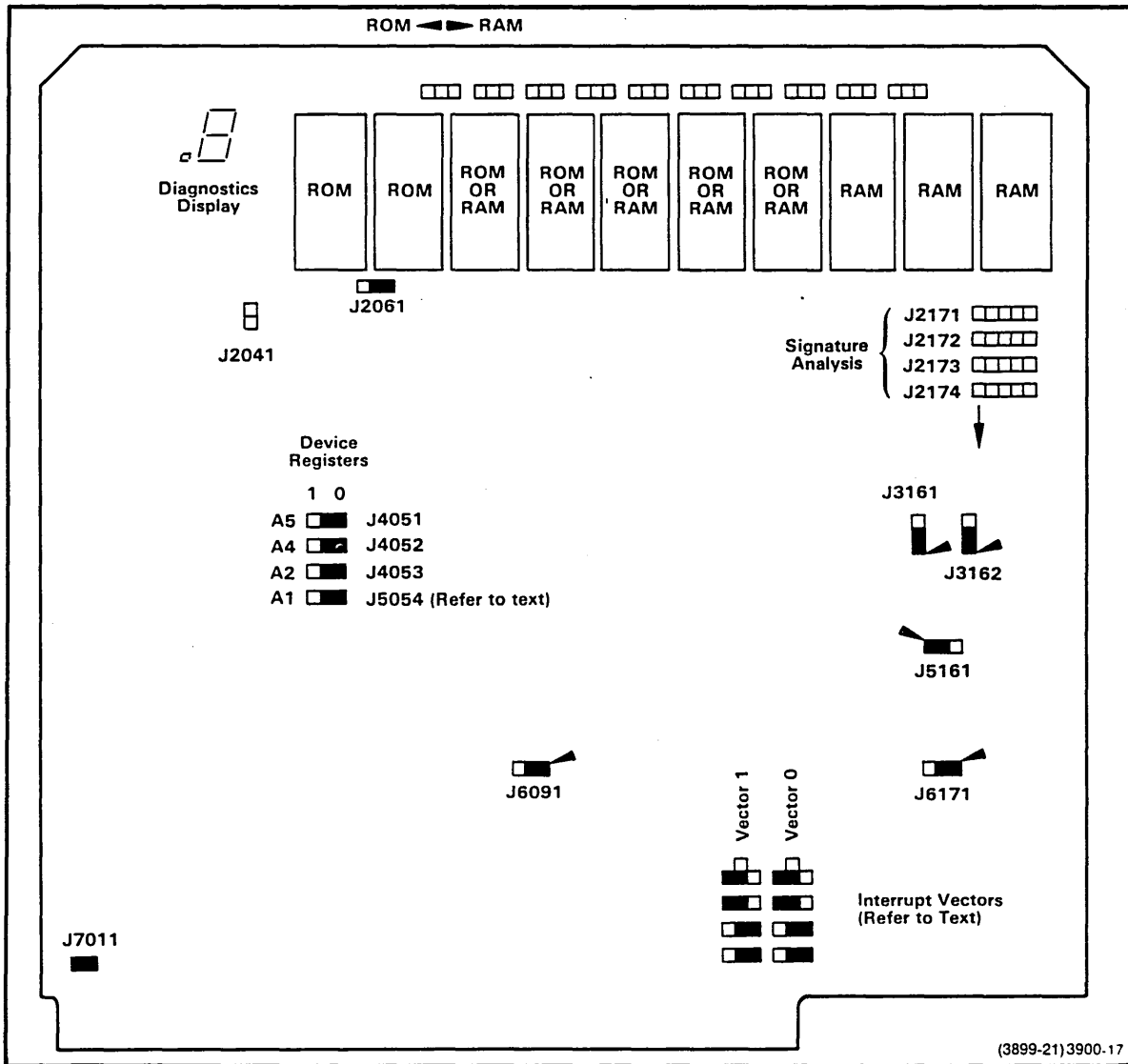

Fig. 6-12. I/O Processor Board jumper locations.

Device Registers

An I/O Processor Board is designated as either IOP 1 or IOP 2 by configuration of the Device Register address jumpers. If only one IOP Board is used in the 8560, it must be configured as IOP 1 and installed in the IOP 1 slot in the 8560 card cage. Figure 6-13a illustrates the jumper configuration for IOP 1.

If your 8560 utilizes two IOP Boards, one of these boards must be configured as IOP 1 and installed in the IOP 1 slot, as above. The second board must be configured as IOP 2 and installed in the IOP 2 slot in the card cage. See Fig. 6-13b.

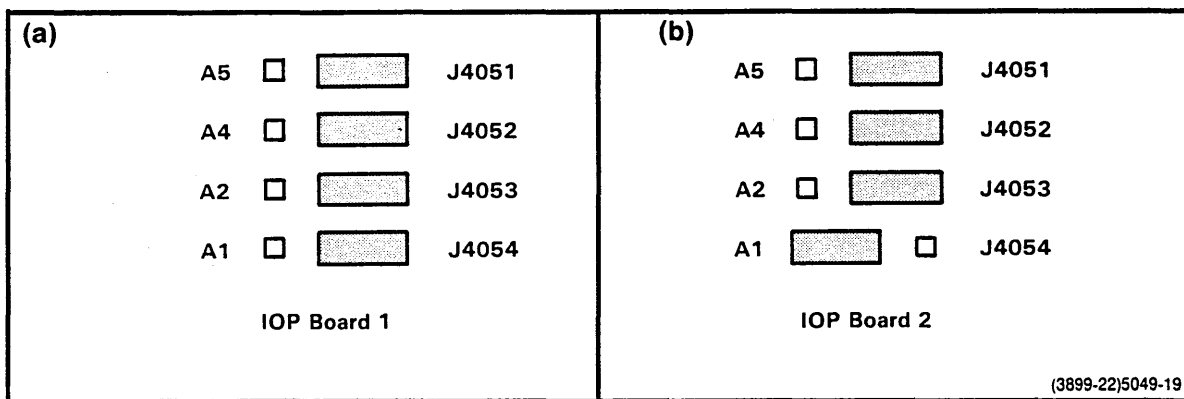

Fig. 6-13. Device Register jumper positions.

Interrupt Vectors

Each of the IOP Boards generates an interrupt vector to the LSI-11 Processor Board. The two interrupt vector circuits can be independently jumpered to select a level of interrupt priority. One set of jumpers determines which interrupt lines will be asserted. The other set of jumpers selects which lines will be monitored when intercepting a grant from the LSI-11 Processor. Table 6-2 describes the various priority levels. Figure 6-14 shows the jumpers for Vectors 0 and 1. Figure 6-15 illustrates jumper configurations for both vectors at priority levels 4, 5, and 6.

Priority level 7 is assigned for LSI-11 use only and is not user-selectable.

Table 6-2
Interrupt Priority Assignments

| Priority Level | Interrupt Lines Asserted | Interrupt Lines Monitored |
|----------------|--------------------------|---------------------------|
| 4 | BIRQ 4 | BIRQ 5, 6 |
| 5 | BIRQ 4, 5 | BIRQ 6 |
| 6 | BIRQ 4, 6 | BIRQ 7 |

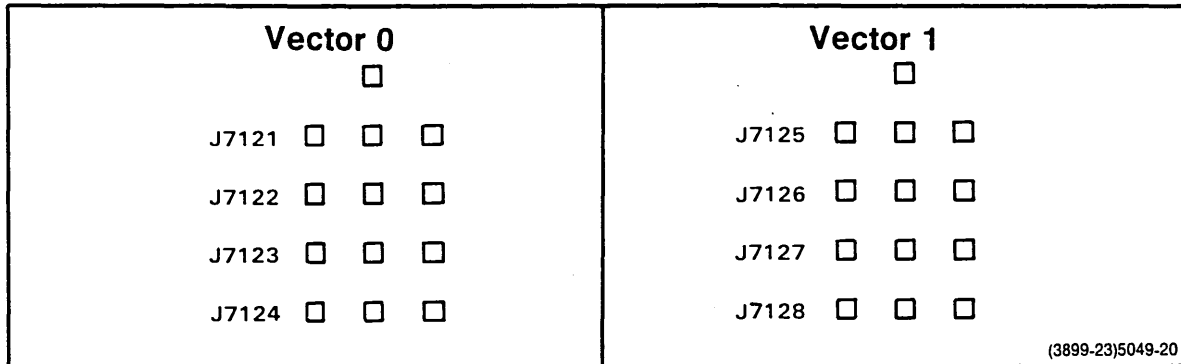

Fig. 6-14. Interrupt priority jumpers.

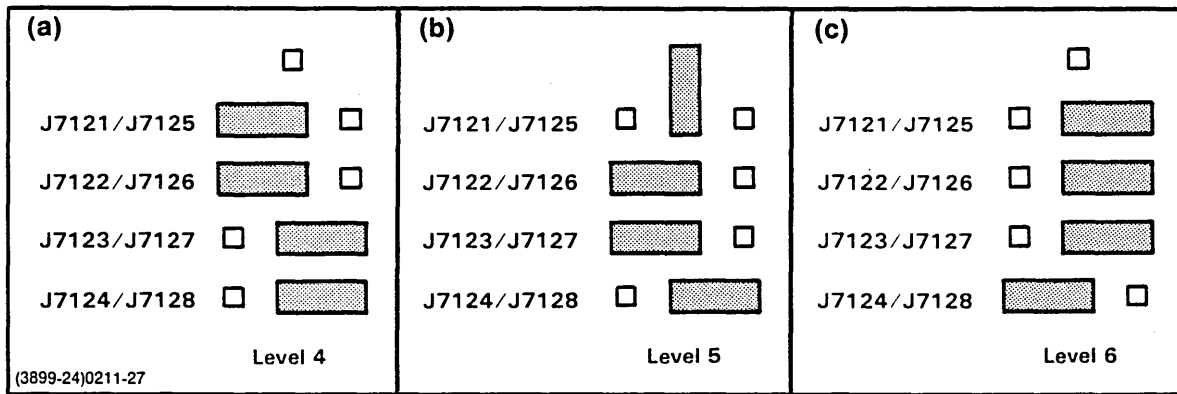

Fig. 6-15. I/O Adapter Board Jumper configurations for interrupt priority levels.

I/O BOARDS

I/O Adapter Board

Jumpers on the I/O Adapter Board allow you to designate the HSI I/O connectors on the 8560 rear panel for either RS-422 (HSI) or RS-232-C I/O protocol. Figure 6-15 illustrates the location of the jumpers on the board. The table in Fig. 6-16 defines the relationship between the jumpers and the rear panel connectors.

NOTE

HSI Port 0 is factory-jumpered for RS-232-C protocol for use with a system terminal. HSI I/O Port Connectors 0 through 7 do not conform to the EIA RS-422 pinout specification. Refer to Appendix B, Table B-4, for HSI Port Connector pin assignments.

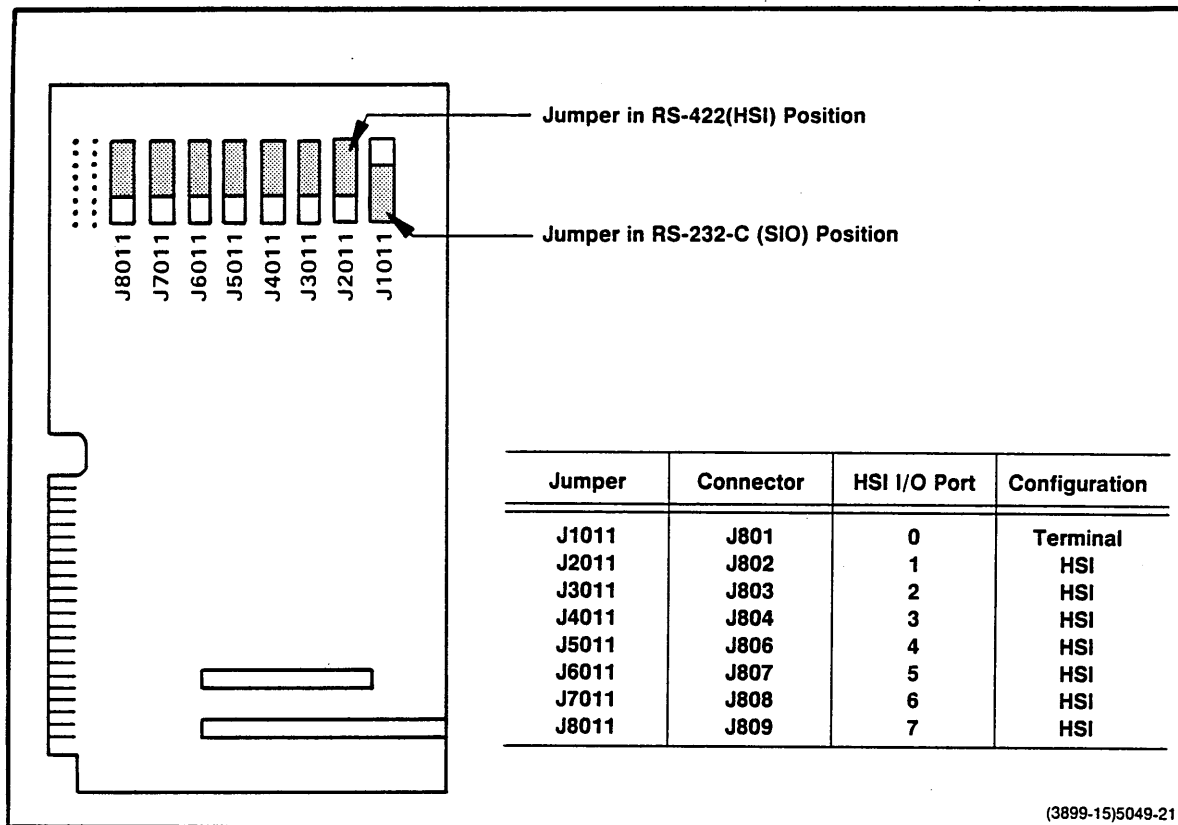

Fig. 6-16. Location of jumpers on the I/O Adapter Board.

I/O Connector Board

Straps, or "cuttable runs," on the I/O Connector Board connect the interface cable shields to the 8560 system ground. For special system configurations that require an ungrounded shield at the 8560 end of the cables, these runs must be cut. For further information about these straps, contact your Tektronix field service representative.

There are no jumpers on the I/O Connector Board.

Main Interconnect Board

The Main Interconnect Board provides seven pairs of bus grant jumpers (J19 through J32). Each board that plugs into the Main Interconnect Board, except for the LSI-11 Board and the Utility Board, has an associated pair of bus grant jumpers.

Jumper pairs are either set to the PASS or the NO PASS position. In the PASS position, the bus grant is passed to the next in-line board. In the NO-PASS position, the grant is passed or intercepted by the board.

Figure 6-17 shows the location of the bus grant jumpers. All empty slots and the system memory boards are jumpered to PASS. All other slots are jumpered to the NO PASS condition. If you need to change the jumpers, remove the adjacent board and use needle-nose pliers to reposition the jumper.

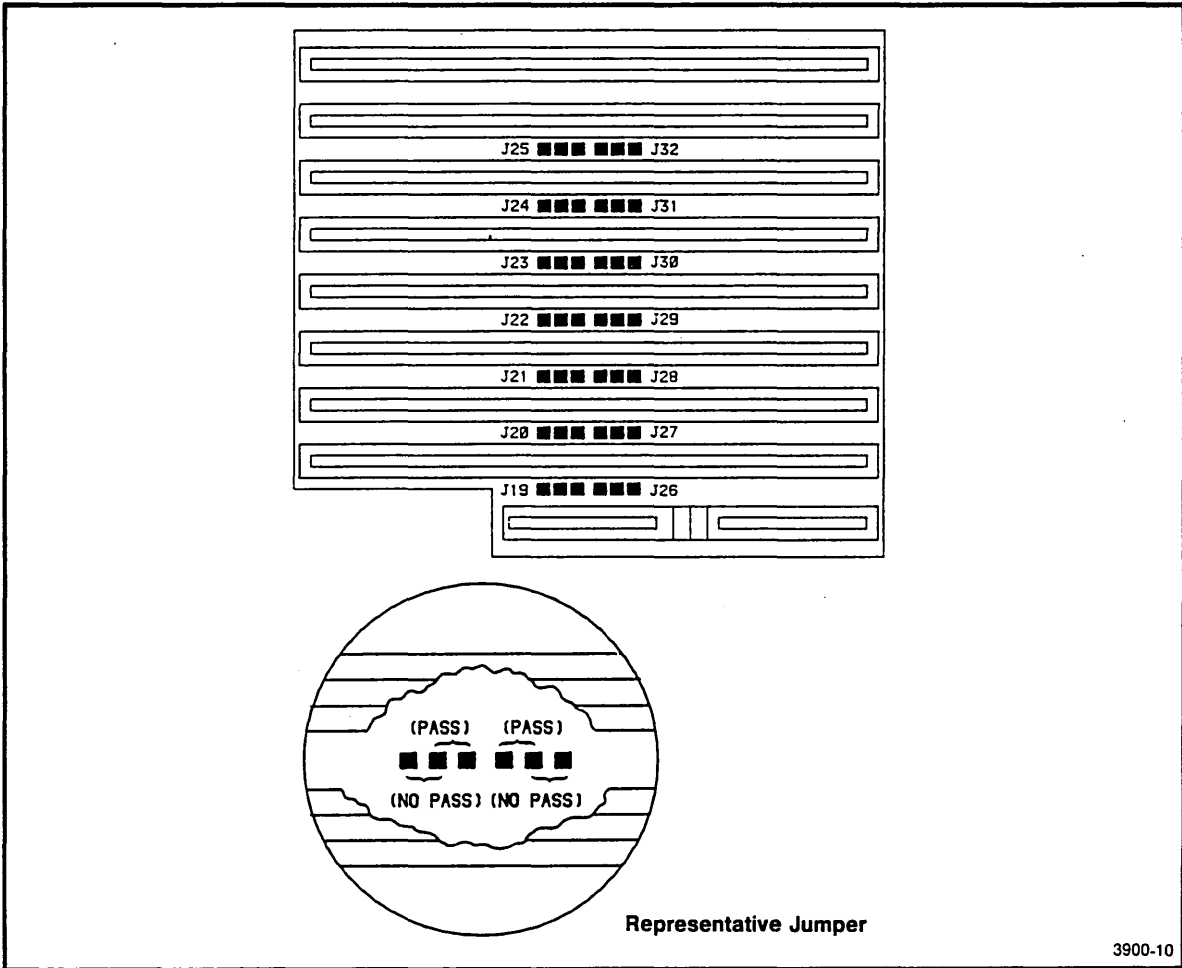

Fig. 6-17. Main Interconnect Board jumper locations.

Table 6-3 shows the default jumpering of the bus grant jumpers. These jumpers pass the bus grant to the next card if the next in-line slot is empty.

Table 6-3
Bus Grant Jumpers

| Jumper | Default |
|--------|---------|
| J19/26 | NO PASS |
| J20/27 | PASS |
| J21/28 | PASS |
| J22/29 | PASS |
| J23/30 | PASS |
| J24/31 | PASS |
| J25/32 | NO PASS |

Power Supply Board Configurations

The 8560 power supply has two boards which have jumpers: the Secondary Board and the Regulator Board. All other power supply boards have no jumpers. Tables 6-4 and 6-5 show the jumpers and their functions. Figures 6-18 and 6-19 show the jumper locations. Most power supply jumpers are used for troubleshooting. Except for P7017 and P7075, all jumpers are normally installed.

Table 6-4
Secondary Board Jumpers

| Jumper | Function | Default |
|--------|---|---------|
| P4114 | overvoltage protection | IN |
| P4102 | overcurrent protection for -12 V output | IN |
| P4112 | overcurrent protection for +24 V output | IN |
| P4097 | overcurrent protection for +5 V output | IN |
| P4116 | overcurrent protection for +12 V output | IN |

Table 6-5
Regulator Board Jumpers

| Jumper | Function | Default |
|--------|----------------------------------|-----------|
| P7017 | Fan connection | No jumper |
| P7047 | Low line voltage shutdown | IN |
| P7048 | Thermal shutdown | IN |
| P7075 | External power supply connection | No jumper |

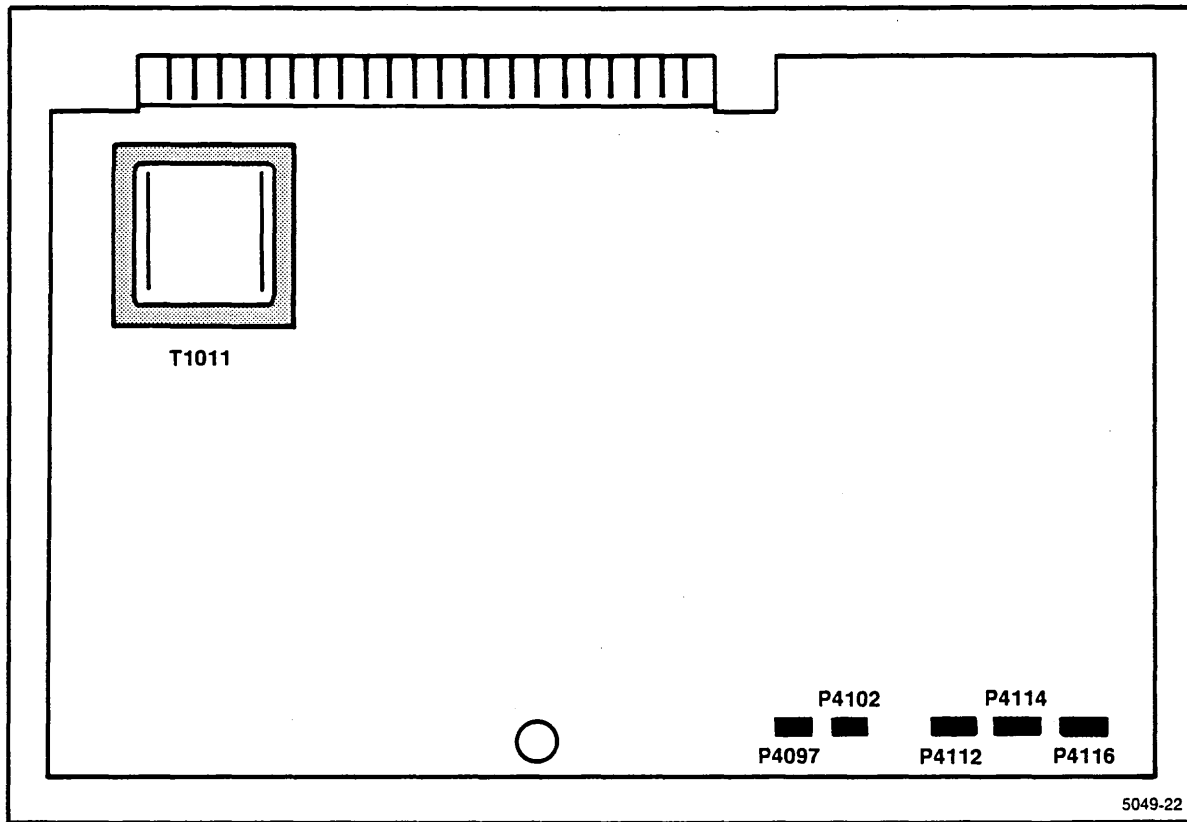

Fig. 6-18. Secondary Board jumper locations.

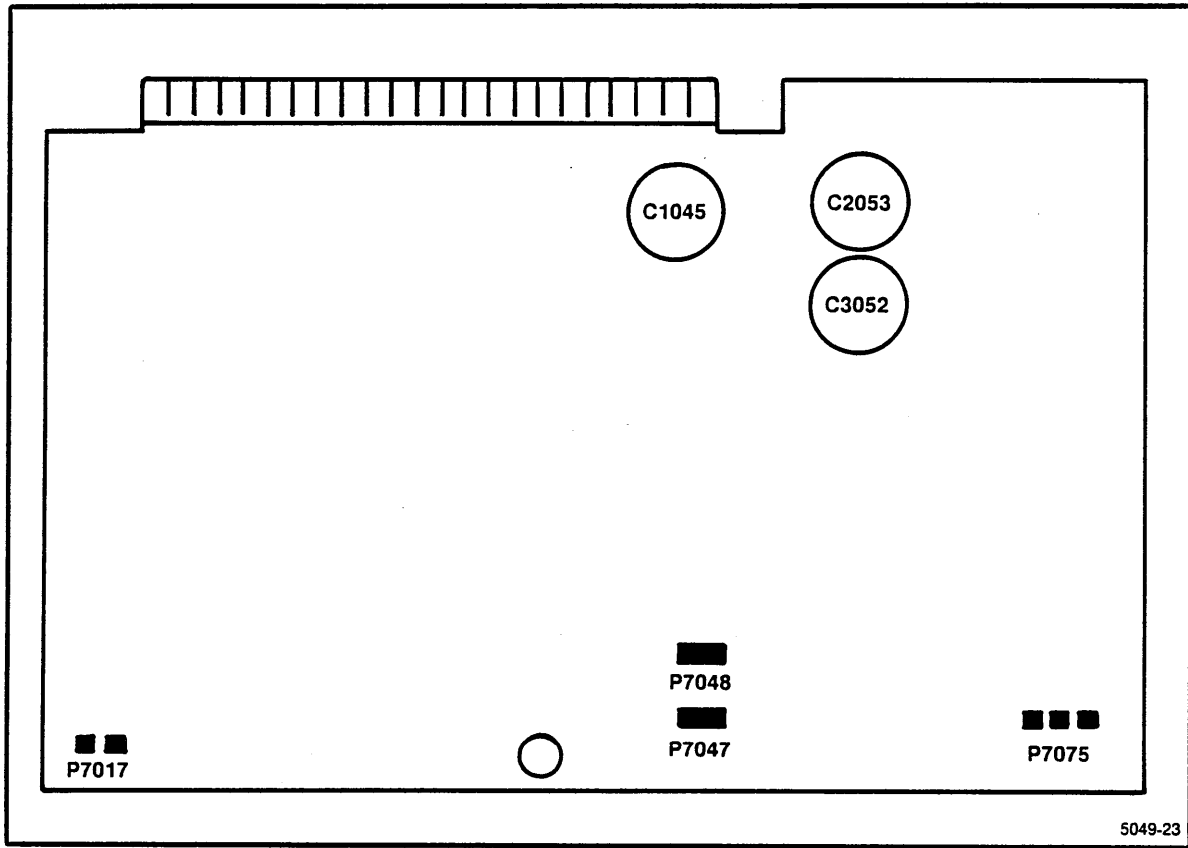

Fig. 6-19. Regulator Board jumper locations.

Section 7 PREPARATION FOR OPERATION

| | Page |
|--|------|
| Introduction | 7-1 |
| Installing the System Terminal | 7-1 |
| Configuring the System Terminal | 7-1 |
| Connecting the System Terminal | 7-2 |
| System Verification | 7-3 |
| Power-Up Procedure | 7-3 |
| System Verification Procedure | 7-4 |
| Verify Operation with One Terminal | 7-4 |
| Run the Disk-Based Diagnostics | 7-5 |
| Reconfiguring TNIX for Additional Users | 7-7 |

ILLUSTRATIONS

| Fig. No. | | Page |
|-------------|--|------|
| 7-1 | I/O Adapter Board jumper locations | 7-2 |

Section 7

PREPARATION FOR OPERATION

INTRODUCTION

This section shows how to install and configure your system terminal, and how to use the power-up and system diagnostics to verify that the 8560 is operating correctly.

WARNING

To avoid injury to yourself or damage to the equipment, turn off all power to the equipment before accessing its internal circuits.

INSTALLING THE SYSTEM TERMINAL

Configuring the System Terminal

Depending on your 8560's configuration, up to eight terminals may be connected to the 8560. The terminal connected to HSI Port 0 (which has been factory-jumpered for RS-232-C compatibility) is designated as the **system terminal**. Before you connect your system terminal, you must set the following terminal characteristics:

- Full duplex
- 2400 baud for transmit and receive
- 8 data bits, 1 stop bit, no parity

See your terminal owner's manual for instructions.

Connecting the System Terminal

The 8560 provides up to eight HSI ports. Any HSI port can provide direct interface to the system terminal. HSI Port 0 is factory-jumpered for RS-232-C protocol for use with a system terminal. Ports 1 through 7 are configured for RS-422 protocol. Any port may be reconfigured for either RS-232-C or RS-422 protocol using jumpers located on the I/O Adapter Board. (See Fig. 7-1.)

Perform the following procedure to connect the terminal to the 8560:

1. Connect the interface cable between the terminal and HSI Port 0 on the 8560's rear panel.
2. Plug the 8560 and the terminal into a power source.

Now proceed to the following system verification procedures.

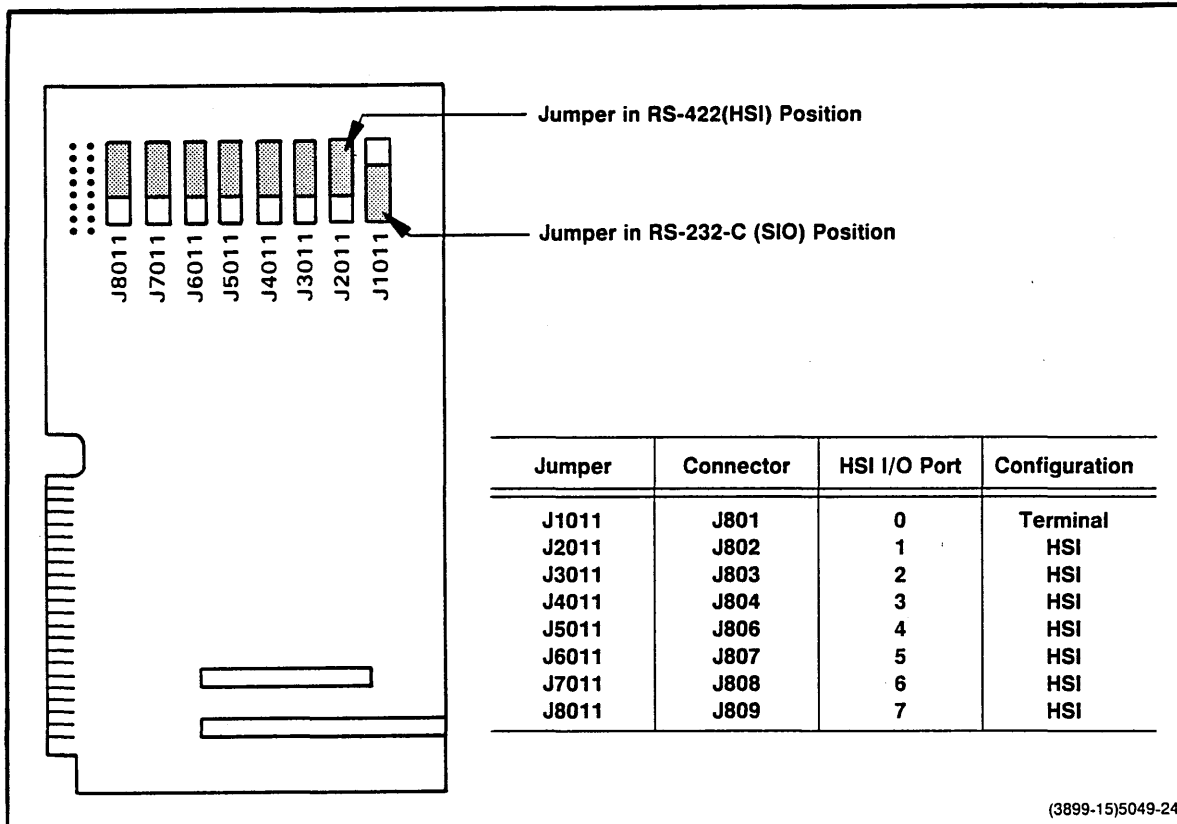

Fig. 7-1. I/O Adapter Board jumper locations.

SYSTEM VERIFICATION

This subsection describes 8560 system verification, which consists of two parts: ROM-based verification routines that execute automatically during power-up, and disk-based diagnostic programs that are executed through menu selection from the system terminal after all power-up tests have passed.

Menu-driven diagnostics are contained on a separate flexible disk and are executed from the system terminal after they are loaded into the 8560 memory. This procedure tests the following 8560 components in the order listed here:

- RAM
- ROM
- LSI-11 CPU
- Line Time Clock
- Line Printer Ports
- I/O Processor
- Mass Storage Controller (MSC)

Power-Up Procedure

NOTE

Before you use this procedure, your 8560 and the system terminal should be properly installed and connected to an AC power source.

1. Turn on the system terminal and allow it to warm up.
2. When the terminal is warmed up, turn on the 8560's AC POWER switch, located on the 8560 rear panel. The AC ON indicator on the front panel will light.
3. Move the 8560's front panel DC ON/OFF switch to the ON position, causing the DC ON and PROCESSOR BUSY indicators to light.

After a short time interval, the LED on the hard disk drive will light, indicating that the hard disk drive is at operating speed.

CAUTION

To protect the integrity of your filesystem, do not activate the HALT or RESTART switches until you have followed the shutdown procedure outlined in Section 1, "How to Shut Down the System."

If the PROCESSOR BUSY light goes out completely, or if an error message is displayed on the system terminal or a line printer, the power-up diagnostics have detected a fault. Refer to the optional *8560/8561/8562 Multi-User Software Development Unit Service Manual* for troubleshooting procedures. For more information about troubleshooting your 8560, contact your local Tektronix service center.

System Verification Procedure

Verify Operation with One Terminal

After the 8560 has passed its power-up test, you can start up TNIX (the 8560's operating system) by performing the following steps.

1. Open the flexible disk drive door.
2. Power up the system terminal
3. Power up the system:
 - Make sure that the POWER switch on the 8560's rear panel is in the ON position.
 - Move the RUN/HALT switch on the 8560's front panel to the RUN position.
 - Move the DC switch on the 8560's front panel to the ON position. The green light next to the DC switch should go on, and the internal disk should start running.
 - The system automatically boots when you first power it up. Within one minute after you move the DC switch to the ON position, the system displays the following message on the system console:

```
Welcome to TNIX Version X.X
```

This message tells you what version of TNIX is installed on your system, and that the system has started the boot procedure.

4. During the boot procedure, the system will ask you various questions. Answer any question asked during the boot procedure, for example:

```
check the filesystem (y or n)? y
  [You type "y". The syschk program checks the
  integrity of the filesystem, and prints the following:]
checking /dev/rhd0:
  ...checking i-nodes and directory entries...
  ...checking tree structure...
  ...checking free list...
  free list is ok. rebuild free list? (y or n): n [You type "n".]
  0 bad blocks (0 percent)
  52920 free blocks (84 percent)
  19916 free i-nodes (95 percent)
Enter date: 15-apr-84 13:55 [You enter the current date.]
Fri Apr 15 13:55:00 PDT 1984
Do you want to remain single user? (y or n): n [You type "n".]
login: root      [You type "root"]
#               [TNIX responds with the superuser prompt.]
```

If **syschk** reports problems with the filesystem, you have to shut the system down and run the stand-alone version of the **syschk** program. Refer to the procedures "How to Shut Down the System" and "Recovering from a System Crash" in Section 1 for additional information.

NOTE

In a new 8560, the root account does not require a password. If system security is important to the proper operation of your system, you should establish an appropriate password for the root account as soon as possible. For more information on the function and use of the root account, see Section 1.

Run the Disk-Based Diagnostics

After you have successfully verified operation with one terminal, you are ready to run the 8560 disk-based diagnostics. The following instructions tell how to use the system diagnostics but do not provide a complete 8560 diagnostics description. For a full description of these diagnostics, refer to the optional *8560/8561/8562 Multi-User Software development Unit Service Manual*.

To verify system operation, perform the following procedure:

1. Insert the 8560 System Diagnostics Disk (label side up) into the 8560's flexible disk drive.
2. Close the disk drive door.
3. Toggle the front panel RESET switch. Within 20 seconds, the 8560 begins a preliminary disk read operation.
4. The system terminal displays the following information:
8560 DIAGNOSTIC DISK V x.x

NOTE

This message is transmitted at 2400 baud. If the message is not readable, the terminal is not operating at 2400 baud.

5. If the terminal is not set for 2400 baud, press the BREAK key one or more times until the following message is displayed:
NEW BAUD RATE SELECTED
6. Press the return key if the terminal displays the following message:
PRESS RETURN TO SELECT TERMINAL
This message appears within 12 seconds if more than one terminal is online.
7. The 8560 diagnostics will now display the Option Menu. (See Display 7-1.)

```
*****8560 Diagnostics - Version X.X - loaded*****
```

```
Option menu
```

```
-----
```

```
0 - Run all tests [default]
1 - Test 8560 RAM
2 - Test 8560 ROM
3 - Test 8560 processor
4 - Test 8560 line-time clock
5 - Test 8560 printer ports
6 - Test 8560 IOP channels
7 - Test disk drives
8 - Test 8560 GPIB Controller
H - Help
```

```
Type in option (<cr>) or (0 - 8 or h and <cr>)
```

```
?
```

Display 7-1.

8. Press the RETURN key as soon as the system terminal displays the Option Menu. The terminal will now display the Loop Control Menu. (See Display 7-2.)

```
Loop control menu
-----

1 - Do not loop on test [default]
2 - Loop on test
3 - Loop until error
H - Help

Type loop control (<cr>) or {0 - 3 or h and <cr>}
?
```

Display 7-2.

9. Press the RETURN key as soon as the Loop Control Menu is displayed. The terminal then shows the Display Mode Menu. (See Display 7-3.)

```
Display mode menu
-----

1 - Display run-time status [default]
2 - No run-time display
H - Help

Type in mode (<cr>) or {1 - 2 or h and <cr>}
?
```

Display 7-3.

10. Press the RETURN key after the Display Mode Menu is displayed. The terminal first displays the run-time status, followed by the Display Output Menu. (See Display 7-4.)

```
Display output menu
-----

1 - Display on terminal [default]
2 - Display on printer 1
3 - Display on printer 2
H - Help

Type in display output (<cr>) or {1 - 3 or h and <cr>}
?
```

Display 7-4.

11. Press the RETURN key again and the diagnostics will begin to execute.

The 8560 disk-based diagnostics require about two minutes to execute. At the end of that time, the system terminal will display either:

```
8560 verification passed
```

or

```
8560 verification failed
```

If the “8560 verification failed” message is displayed, the diagnostics detected a fault in the 8560. In that case, refer to the optional *8560/8561/8562 Multi-User Software Development Unit Service Manual*, for detailed diagnostic troubleshooting procedures.

If the “8560 verification passed” message is displayed, refer to Section 1 and start common system operations, such as:

- Creating user accounts and user groups on the system
- Installing optional software

You can also connect peripherals and workstations to the 8560. First, set up and verify each peripheral or workstation as described in its installation manual (or owner’s manual). Then, attach each peripheral or workstation to the 8560 as described in Section 2.

RECONFIGURING TNIX FOR ADDITIONAL USERS

The Four-User Upgrade Option (for the 8561) requires installation of a different I/O Connector (IOC) Board and a modification to the TNIX operating system. The Eight-User Upgrade Option (for the 8560 and 8561) requires installation of a second I/O Processor (IOP) Board, a different I/O Connector (IOC) Board, and a modification to the TNIX operating system. (Information on installing a second IOP Board is located in Section 5.) If an upgrade option has been installed in your system, you must reconfigure TNIX to accommodate the additional number of users. Complete the following procedure:



Verify that the second IOP Board is properly installed in the 8560 before you reconfigure the system for eight users. Failure to do so will cause the system to crash.

NOTE

Prior to powering up, make sure that all the HSI ports involved in your optional upgrade have been appropriately jumpered for RS-232-C or RS-422 protocol depending on your requirement. Refer to Fig. 6-15 in Section 6 for the I/O Adapter Board jumper locations.

1. If you have not yet done so, perform the Power-Up Procedure, described earlier in this section.

2. During the boot procedure, when the system asks if you want to remain "single user", type "y" and press the RETURN key. The "#" prompt appears, indicating that you have superuser privileges.
3. Enter the following commands on the system terminal connected to the 8560:

| 4-User Upgrade Option | 8-User Upgrade Option |
|-----------------------|---------------------------|
| # ed /etc/ttys | # chmod 622 /dev/tty[4-7] |
| 1,2t2 | # ed /etc/ttys |
| 3s/0\$/2/ | 1,4t4 |
| 4s/1\$/3/ | 5s/0\$/4/ |
| w | 6s/1\$/5/ |
| q | 7s/2\$/6/ |
| # | 8s/3\$/7/ |
| | w |
| | q |
| | # |

When the superuser prompt (#) appears, reboot the 8560 as described earlier in this section, "Verify Operation with One Terminal."

The 8560 operating system is now configured to operate with four or eight HSI I/O ports.

Appendix A

CONTROLS, CONNECTORS, AND INDICATORS

The following paragraphs briefly describe controls, connectors, and indicators on the front and rear panels of the 8560 Series Multi-User Software Development Unit.

FRONT PANEL CONTROLS AND INDICATORS

There are three switches on the 8560 front panel: the DC ON/OFF switch, the system RESTART switch, and the RUN/HALT switch. There are also three indicators on the front panel: DC ON, AC ON, and PROCESSOR BUSY. Front panel controls and indicators are identified in Fig. A-1.

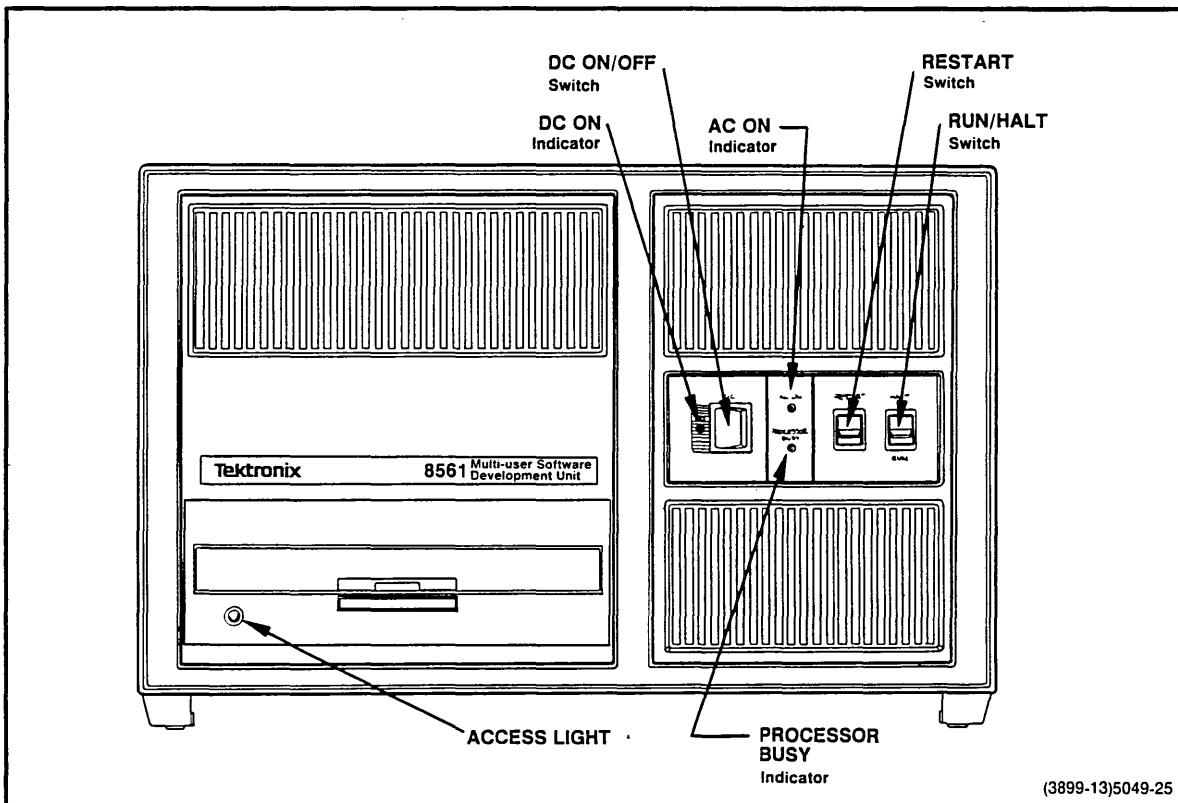

Fig. A-1. 8560 front panel controls and indicators.

DC ON/OFF Switch

This two-position rocker switch controls dc power to the 8560's logic circuits.

DC ON Indicator

The DC ON indicator illuminates when +5 Vdc power is present in the 8560.

RESTART Switch

This switch is a two-position, spring-return toggle switch. When the RESTART switch is toggled upward, the 8560 will reboot, depending on internal processor board configuration and the position of the RUN/HALT switch.

RUN/HALT Switch

The RUN/HALT switch selects the 8560 operating mode: RUN for normal program execution, HALT for special operations controlled by peripheral devices.

AC ON Indicator

This indicator illuminates whenever the rear panel POWER switch is in the ON position and primary ac power is applied to the 8560.

PROCESSOR BUSY

The PROCESSOR BUSY indicator is normally illuminated during program execution but is off when the processor is halted, or waiting for an interrupt after executing a Wait for Interrupt (WAI) command.

REAR PANEL CONTROLS AND CONNECTORS

The rear panel contains primary power components and all I/O interface connectors. Rear panel controls and connectors are identified in Fig. A-2.

Power Cord Receptacle

The line cord connects to this receptacle, supplying primary ac power to the 8560.



Connect the line cord only to the line voltage indicated on the primary voltage indicator plate, as shown in Fig. A-2.

Line Fuse

Use only a fuse rated as indicated on the primary voltage indicator plate:

- For 115 Vac operation, use a 3AG, 8 Amp, 250 Volt, fast-blow fuse.
- For 230 Vac operation, use a 3AG, 4 Amp, 250 Volt, fast-blow fuse.

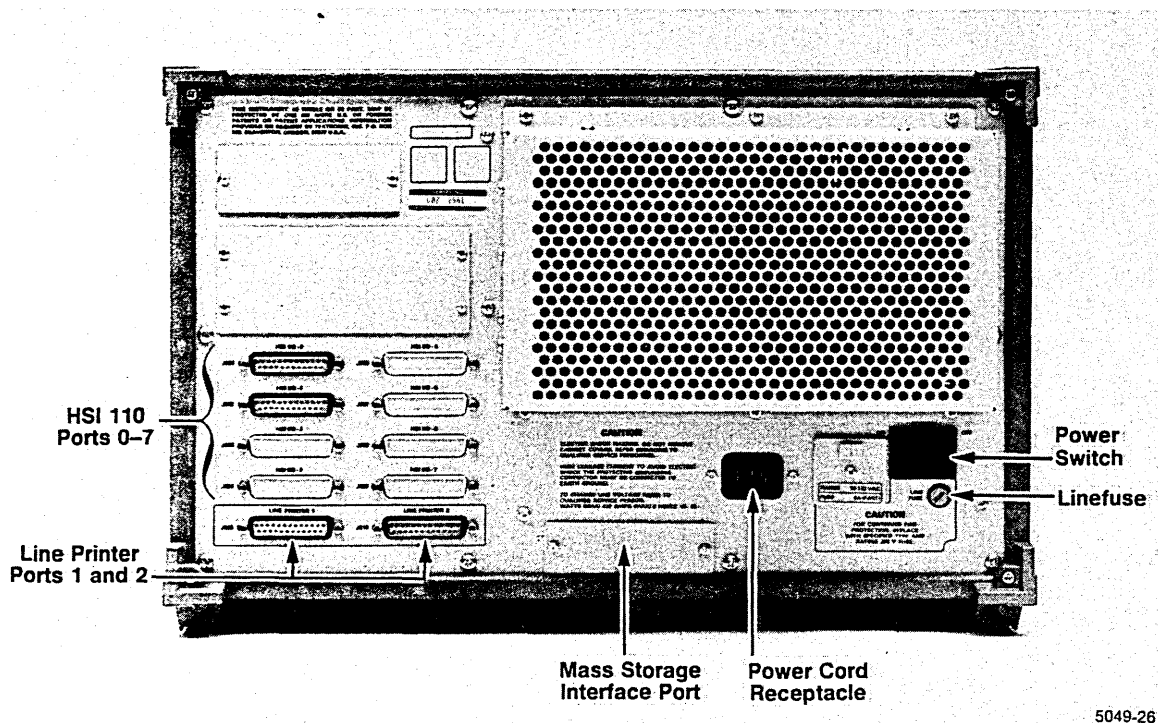

5049-26

Fig. A-2. 8560 rear panel controls and indicators.

Primary Voltage Selector Switch

This switch selects the primary power source for the 8560. A cover plate over the switch indicates which of the two possible voltage ranges is selected: 90-132 Vac or 180-250 Vac.



If you change the primary voltage range, be sure to replace the line fuse with a fuse rated for the new voltage range. (Refer back to the previous "Line Fuse" discussion.)

POWER Switch

This two-position rocker switch controls input ac power to the 8560. When primary power is applied and the POWER switch is ON, the AC ON indicator on the front panel will be illuminated.

HSI I/O Ports 0 through 7

HSI Port 0 is factory-jumpered for RS-232-C protocol for use with a system terminal. Ports 1 through 7 are configured for RS-422 protocol. Any one of Ports 0 through 7 may be reconfigured for either RS-232-C or RS-422 protocol by moving jumpers on the I/O Adapter Board.

NOTE

Standard 8560 configuration includes only Ports 0 through 3, and Ports 4 through 7 are optional. Standard 8561 configuration includes only Ports 0 and 1, and Ports 2 through 7 are optional. Standard 8562 configuration includes Ports 0 through 7.

Line Printer Ports 1 and 2

Line Printer Ports 1 and 2 are dedicated RS-232-C I/O Ports used to attach line printers to the 8560.

Appendix B

SPECIFICATIONS

CHARACTERISTICS

Table B-1 lists the 8560's electrical characteristics. Table B-2 lists the 8560's environmental characteristics, and Table B-3 lists its physical characteristics.

Table B-1
Electrical Characteristics

| Characteristic | Performance Requirements | Supplemental Information |
|----------------------------------|---|--|
| Primary Power Input Voltages | 90 to 132 Vac 180 to 250 Vac | |
| Frequency | 48 to 66 Hz | |
| Line Fuses 115 Vac 230 Vac | | 3AG, 8 Amps, 250 Volt, fast-blow 3AG, 4 Amps, 250 Volt, fast-blow |
| Power Consumption (maximum) | | 410 Watts |
| Power Supply | +5.0 Vdc +/- 3% +12.0 Vdc +/- 5% -12.0 Vdc +/- 5% +15.0 Vdc +/- 10% +24.0 Vdc +/- 10% | 33 A 6.5 A 260 mA 20 ma 1.0 A |
| Static Discharge (Operating) | | 12.5 kV and below with no effect on operation of unit |

Table B-2
Environmental Characteristics

| Characteristic | Description |
|-------------------------------------|---|
| Temperature Operating Storage | +10° C to +35° C (+50° F to +95° F) -10° C to +45° C (+14° F to +113° F) |
| Humidity Operating | 20% to 80% noncondensing 26° C (79° F) maximum wet bulb |
| Altitude Operating Storage | To 2 500 m (8,000 feet) To 9 140 m (30,000 feet) |

Table B-3
Physical Characteristics

| Characteristic | Description |
|-----------------------|--------------------|
| Net Weight | 22.4 kg (49.2 lb.) |
| Overall Dimensions | |
| Height | 267 mm (10.5 in.) |
| Width | 432 mm (17 in.) |
| Length | 646 mm (25.4 in.) |

PORT SPECIFICATIONS

The following text and tables provide specifications and connector pin assignments for the 8560 HSI I/O and line printer ports, and for the 8540 terminal port.

HSI I/O Port Specifications

HSI I/O Port 0 is a 25-pin female connector, factory-jumpered for RS-232-C protocol for use with a system terminal. HSI I/O Ports 1 through 7 are 25-pin female connectors, factory-configured for RS-422 protocol. Table B-4 identifies the interface connector pins.

Any HSI I/O port may be reconfigured for either RS-232-C or RS-422 protocol. RS-232-C configurations use only the positive side of the balanced signals. Jumpers on the I/O Adapter Board determine whether a port is compatible with RS-422 or with RS-232-C protocol.

NOTE

HSI I/O Port Connectors 0 through 7, while designed to support either RS-232-C or RS-422 interface signals, do not fully conform to the EIA RS-422 pinout specification.

Table B-4
HSI Port Connector Pin Assignments

| Pin No. | Description | Symbol | Comments |
|---------|------------------|--------|--------------------------|
| 1 | Shield | | |
| 7 | Signal Ground | | |
| 2 | Transmit Data | Tx | Data received by 8560 |
| 11 | Transmit Data | Tx' | |
| 3 | Receive Data | Rx | Data transmitted by 8560 |
| 12 | Receive Data | Rx' | |
| 20 | Data Track Ready | DTR | |
| 13 | Data Track Ready | DTR' | |
| 5 | Clear to Send | CTS | |
| 25 | Clear to Send | CTS' | |
| 6 | Data Set Ready | DSR | Always transmitted On |
| 18 | Data Set Ready | DSR' | Always transmitted On |
| 8 | Carrier Detect | DCD | Always transmitted On |
| 9 | Carrier Detect | DCD' | Always transmitted On |
| 4 | Ready to Send | RTS | Always transmitted On |
| 10 | Ready to Send | RTS' | Always transmitted On |

Note: Pins DSR, DCD, RTS, DSR', DCD', and RTS' are normally not used.

Line Printer Port Specifications

Each of the 8560's two line printer ports is a 25-pin female connector, normally configured as a RS-232-C interface. Table B-5 lists pin assignments for the RS-232-C line printer port connectors.

NOTE

Line printer ports are preset at the factory for 2400 baud. If you need a different baud rate, reconfigure the Utility Board as described in Section 6 of this manual.

Table B-5
RS-232-C Interface Connector Pin Assignments

| Pin No. | Description | Symbol | Comments |
|---------|---------------------|--------|-----------------------|
| 1 | Protective Ground | | |
| 2 | Transmit Data | Tx | Data received by 8560 |
| 3 | Receive Data | Rx | Data sent by 8560 |
| 4 | Request to Send | RTS | |
| 5 | Clear to Send | CTS | |
| 6 | Data Set Ready | DSR | Always transmitted ON |
| 7 | Signal Ground | | |
| 8 | Data Carrier Detect | DCD | Always transmitted ON |
| 15, 17 | External Clock | | |
| 20 | Data Terminal Ready | DTR | |

8540 Terminal Port Configuration

The 8540's TERMINAL Port is a 25-pin, RS-232-C-compatible rear panel female connector (J104). Table B-6 shows the port's pin configuration. If your terminal uses a different signal arrangement, a null modem may be required to adapt your terminal to the 8540. If a TEKTRONIX 4105, CT8500, 4024, or 4025 terminal is used, a null modem is not necessary.

Table B-6
8540 TERMINAL Port Pin Configuration

| Pin No. | Symbol |
|---------|-----------|
| 1 | Shield |
| 2 | Tx |
| 3 | Rx |
| 4 | RTS |
| 5 | CTS |
| 6 | DSR |
| 7 | LOGIC GND |
| 8 | DCD |
| 17 | — |
| 20 | DTR |

Appendix C

INTERFACE SIGNAL CONNECTIONS

Figures C-1, C-2, C-3, and C-4 show the most commonly used system configurations. These configurations are described in more detail in Section 2.

Figures C-1 and C-2 show the RS-422 and RS-232-C interface signals, respectively. Figure C-3 shows a typical terminal (RS-232-C) interface, and Fig. C-4 shows a typical line printer (RS-232-C) interface.

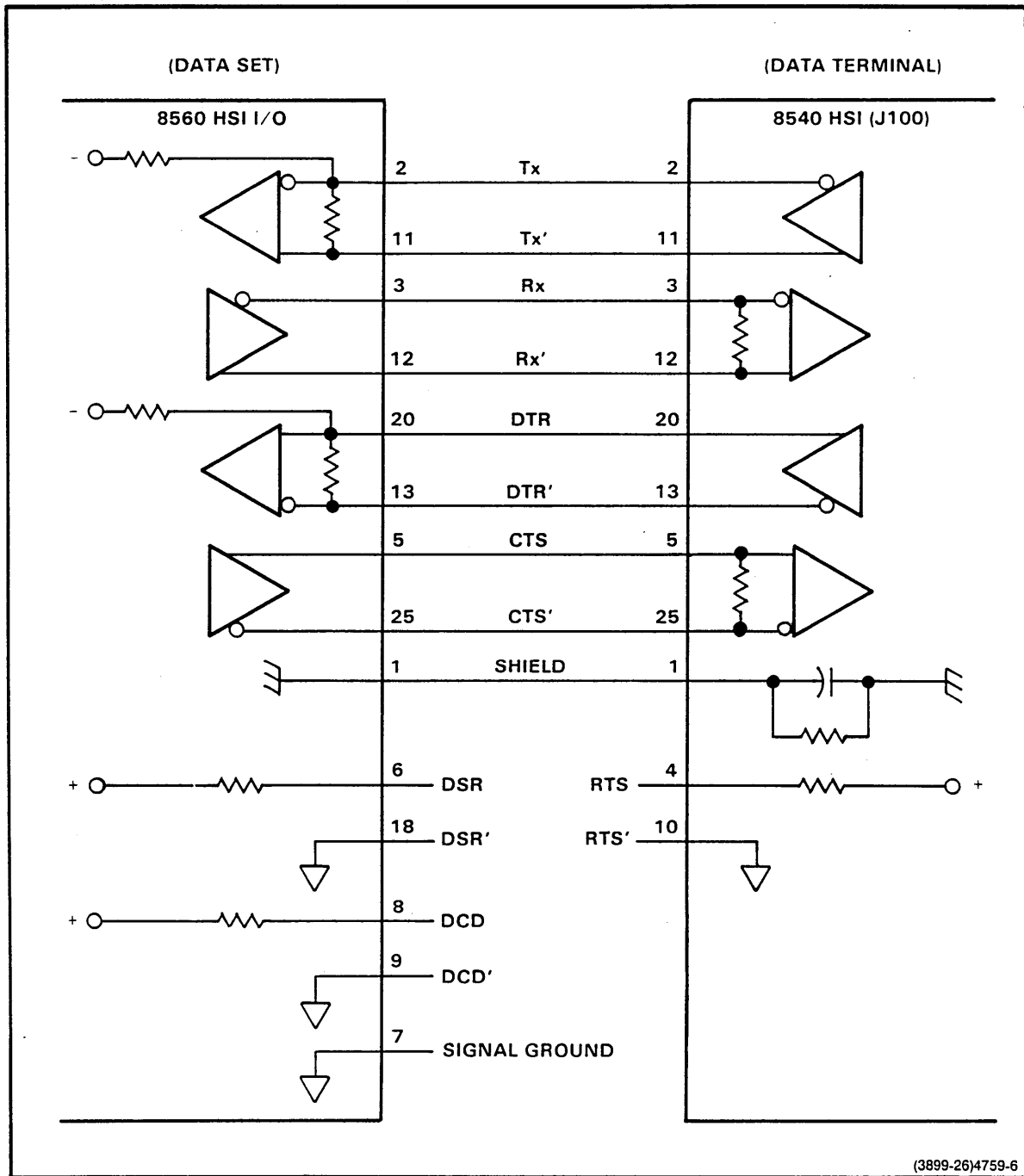

Fig. C-1. RS-422 signal lines between the 8560 and the 8540.

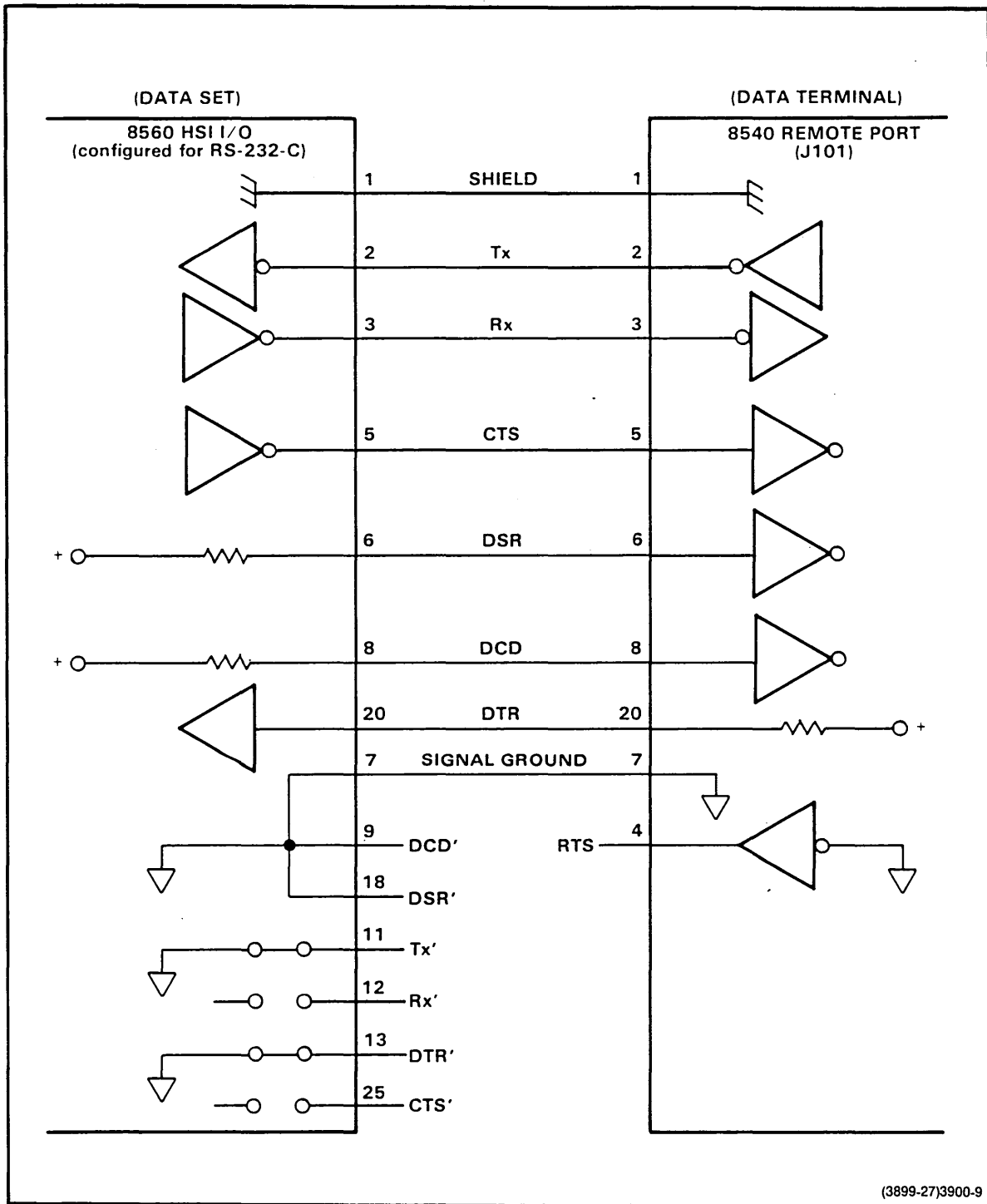

Fig. C-2. RS-232-C interface lines between the 8560 and the 8540.

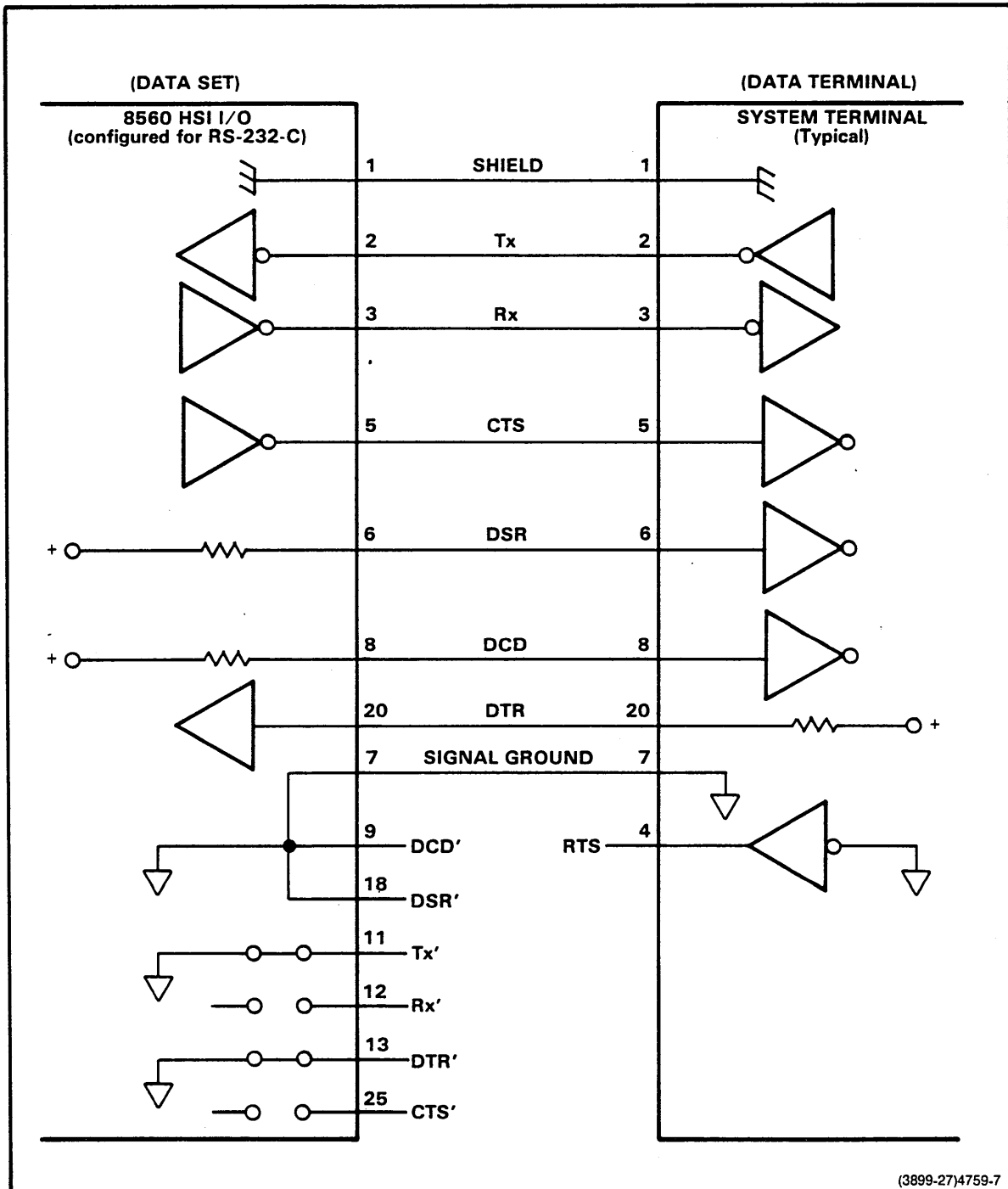

Fig. C-3. A typical RS-232-C system terminal interface with the 8560.

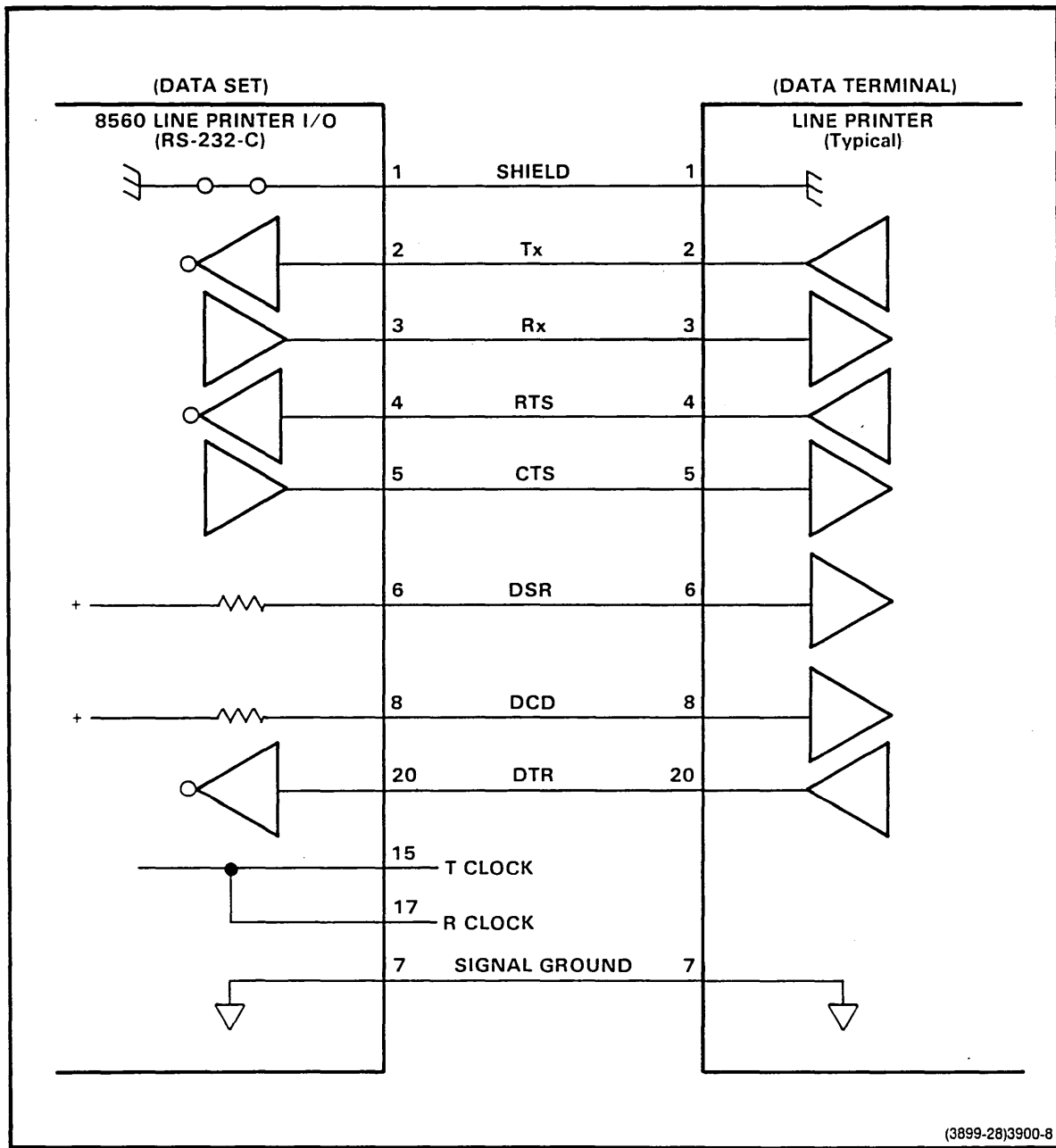

Fig. C-4. A typical line printer interface with the 8560.

Appendix D

INDEX

- '.' entry missing, 3-25
- '.' entry incorrect, 3-23
- ..' entry incorrect, 3-23
- ..' entry missing, 3-24
- ,profile file, 1-13
- /dev/rhd0 logical device, 1-2, 1-3, 1-23
- /dev/rhd01 logical device, 1-3
- /dev/rhd02 logical device, 1-3
- /dev/rhd03 logical device, 1-3
- /dev/rhd1 1-28
- /etc/checklist file, 1-17
- /etc/ddate file, 3-9, 3-10
- /etc/directory, 1-8, 1-29
 - problems with files in, 1-30
- /etc/group file, 1-13
- /etc/motd file, 1-15
- /etc/passwd file, 1-14 thru 1-15
- /etc/rc file, 1-16
- /etc/ttys file, 1-29, 2-2
- modifying port entry, 2-6, 2-8, 2-10
- port entry, 2-11
- /tnix file, 1-12, 3-7
- /usr/lib/default.profile file, 1-13
- 256K and 512K memory boards, 6-4 thru 6-6
- 8540/8560 configurations, 2-4 thru 2-7
- 8540 Terminal Port, B-4
- 8550/8560 configurations, 2-8 thru 2-10
- 8561, references to, iii, v

A

- accounts, creating and deleting, 1-13 thru 1-15
- AC ON indicator, A-2
- active page register, 1-31
- adding terminals, 8540s, 8550s and printers, Section 2
- Additional Users, Reconfiguring TNIX for, 7-7
- air flow through the 8560, 5-3
- algorithm for performing backups, 1-19 thru 1-20
- algorithm for restoring backups, 1-25 thru 1-26
- altitude, operating, B-2
- assigning passwords, 1-14

B

- backup algorithm, 1-19 thru 1-20, 1-26
- backups, 1-17 thru 1-28, 3-8, 3-18
- creating, 1-17 thru 1-20
 - full, 1-17 thru 1-19
 - incremental, 1-19 thru 1-20
 - periodic, 1-19 thru 1-20
 - restoring, 1-21 thru 1-28, 3-18 thru 3-20

- bad block:
 - i-node, 3-24
 - pointer change, 3-25
- bad blocks, 3-23 thru 3-25
 - adding new, 3-25
 - too many, 3-25
- bad count, 3-23
- bad mode, 3-23
- bad size, 3-23
- bad superblock, 3-23
- bank selection, 6-4
- baud rate, 2-3
 - in /etc/ttys file, 2-3
 - line printer, 2-11
 - selecting, 2-3, 6-14
 - variable, 2-3
- blocks:
 - bad, 3-22, 3-25
 - missing, 3-23
 - out of bounds, 3-24
 - too few, 3-24
- board configuration, 8560, Section 6
- boot block, installing, 1-29, 3-13
- boot, from standalone utilities disk, 1-6
- bootblock, 3-13
- booting the system, 1-4 thru 1-7
- BPT/trace, 1-32
- breakpoint instruction, 1-32
- bus error, 1-31

C

- cable connections, 2-4, 2-5, 2-7 thru 2-10
- cable lengths, 5-3
- changing:
 - a password, 1-3, 1-15
 - kernel parameters, 3-3 thru 3-7
 - the login message, 1-15
 - the system operating mode, 1-8
- checking the filesystem, 1-5, 1-29, 3-21 thru 3-26
- chgrp command, 1-22
- chown command, 1-22
- circuit board:
 - clearance requirements, 5-5
 - configuration, 6-1 thru 6-12
 - restrainer, 5-9
- com command, 8550/8540, 2-7, 2-10, 2-11
- COM Interface software, 2-8
- communicating with an 8550, 2-8 thru 2-10
- communication, establishing, 2-6, 2-7, 2-8, 2-10, 2-11
- communication, via COM command, 2-8

- communications adapters, 4-8
- configuration script, cvt, 3-3
- configurations, 8550/8560, 2-8
- configuring:
 - ports, 2-1 thru 2-3
 - the system terminal, 7-1
- connecting:
 - a line printer, 2-11
 - an 8550 MDL, 2-8 thru 2-10
 - an 8540 Integration Unit, 2-4 thru 2-8
 - terminals, 2-4
- connection failed, 3-23
- connections, cable, 2-4, 2-5, 2-7 thru 2-10
- connector pin assignments, B-3 thru B-4
- controller board jumpers, MSC, 6-8
- controls, connectors, and indicators, Appendix A
- core dump, how to obtain a, 1-33
- core map entries, changing the number of, 3-5
- countdown shell command file, 1-16
- crash causes and error messages, 1-30 thru 1-33
- crashes, recovering from, 1-29
- creating a group, 1-12
- creating backups, 1-17 thru 1-20
- cvt command, 1-23, 1-31, 3-3 thru 3-7
 - error messages, 3-7
 - parameters, 1-26, 3-3
 - script, 3-3
 - scripts, location of, 3-7
 - standalone version, 3-6

D

- date command, 1-6
- DC ON indicator, A-2
- DC ON/OFF switch, A-2
- dead process, 1-31
- debug ROM control jumper, 6-14
- deleting a user's account, 1-13
- deleting passwords, 1-15
- device numbers, major and minor, 3-5
- device register address jumpers, 5-12, 6-16
- diagnostics, disk-based, 7-5 thru 7-7
- dimensions of 8560, B-2
- directory:
 - extension failure, 3-24
 - lost + found, 3-25
 - making a login, 1-13
 - misaligned, 3-23
 - orphan, 3-24
- disk-based diagnostics, 7-5 thru 7-7
- disks, formatting, 1-17, 3-11
- DTE connector (J101), 2-9
- dump command, 1-17, 1-18, 3-1, 3-8 thru 3-10
- dump levels, 1-19
- dumpdir command, 1-21

E

- ed command, 1-15, 1-23
- EMT emulator trap, 1-32
- electrical characteristics, table of 8560, B-1
- encrypted password, 1-15
- environmental considerations, 5-6
- establishing communication, 2-6, 2-7, 2-8, 2-10, 2-11

F

- file recovery, from backups, 1-21 thru 1-23, 3-18 thru 3-20
- filesystem, 3-18
 - checking integrity of, 1-6, 3-21
 - configurations, table of, 3-16
 - making, 1-23, 3-14 thru 3-17
 - non-root, 1-3
 - restoring backups, 1-21
 - restoring backups to the root, 1-23
 - root, 1-3, 3-16
 - mounting, 1-3, 1-17
 - unmounting, 1-17
- Filesystem Configuration Record Sheet, 3-15
- fixed disks, formatting, 3-11 thru 3-12
- flexible disks, formatting, 3-11 thru 3-12
- flexible disks, reading backup data from, 3-18 thru 3-20
- flexible disk head restraint, 5-9
- Floating Point Option, installing, 5-12
- floating point trap, 1-32
- format commands, 1-18, 3-11
- Four-User Upgrade Option, 7-7
- free block pointer out of range, 3-23
- freelist:
 - bad block in, 3-23
 - duplicate in, 3-24
 - rebuilding, 3-24
- front panel controls and indicators, Appendix A
- fuse, line, A-3, B-1

G

- getblk, TNIX internal routine, 1-30
- getfs, TNIX internal routine, 1-30
- GPIB address of tape drive, 3-18
- group ID, numeric, 1-14
- group, listing members of, 1-13
- groups, assigning users to, 1-13
- groups, how to create, 1-12

H

- hard disks, formatting, 3-11 thru 3-12
- head restraint, flexible disk 5-9
- high bank of memory, 6-3
- HSI Ports, 2-1 thru 2-2, B-2 thru B-3
- humidity, operating, B-2

I

- i-node:
 - area overflow, 3-24
 - root not directory, 3-25
 - root unallocated, 3-25
 - too few, 3-25
 - too many, 3-26
 - unallocated, 3-22
- i-number, out of range, 3-24
- I/O:
 - Adapter board, 4-8
 - Adapter board jumpers, 2-4, 2-9, 6-17, 7-2
 - boards, 6-17
 - buffers, changing number of, 3-4
 - Connector Board straps, 6-18
 - Memory jumper, 6-7
 - memory selection, 6-4
 - Processor board, 4-7, 6-15
 - processor (IOP) jumpers, 6-15
- iget, TNIX internal routine, 1-30
- illegal instruction, 1-32
- incorrect link count, 3-24
- incremental backups, 1-19 thru 1-20
- initializing ports, 2-3
- inode table entries, changing the number of, 3-4
- stall command, 1-12
- stallation overview, Section 4
- installing:
 - a group, 1-12
 - a new boot block, 1-29
 - a new version of TNIX, 1-12
 - a user, 1-13
 - an 8560, overview, Section 4
 - an additional IOP board, 5-12
 - options, 5-9 thru 5-14
 - new software, 1-12
 - rack mount guides, 5-10
 - the Eight-User Upgrade Option, 7-7
 - the Floating Point Option, 5-12
 - the Four-User Upgrade Option, 7-7
 - the system terminal, 7-1 thru 7-2
- interface signal connections, Appendix C
- internal disk, 8560, iv, 1-3 thru 1-4, 1-6, 1-18, 1-23 thru 1-27, 1-30
- interrupt priority assignments, 6-16
- interrupt vector jumpers, 6-16
- I/O Adapter board, 6-17
- I/O Connector board, 6-18
- I/O Processor (IOP) board, 4-7, 6-15
 - device registers, 6-15
 - installing additional, 5-12
 - interrupt vectors, 6-16
- IOT I/O trap instruction, 1-32
- jumper:
 - debug ROM control, 6-14

- jumpers, 6-1
 - device register address, 6-16
- I/O adapter board, 2-4, 2-9, 6-18, 7-2
- I/O processor (IOP), 6-15
- interrupt vectors, 6-16
- LSI-11/23 Processor Board, 6-2
- LSI-11/73 Processor Board, 6-3
- Main Interconnect Board, 6-19
- Memory Boards
 - 256K Memory Board, 6-5, 6-7
 - 512K Memory Board, 6-6, 6-7
- Micropolis 1304 Hard Disk Drive, 6-12
- MSC Board, 6-8
- QumeTrak 242 Flexible Disk Drive, 6-10
- Regulator Board, 6-22
- Seagate ST419 Hard Disk Drive, 6-11
- Secondary Board, 6-21
- Utility board, 6-13
- Xebec S1410 Disk Controller, 6-9

K

- kernel size parameters, 3-4 thru 3-5

L

- line fuse, A3, B1
- line printer interface, 6-14, B-3 thru B-4, C-5
- line printer, configuring and connecting, 2-11 thru 2-13, B-3 thru B-4, C-5
- link count, incorrect, 3-24
- logical devices names, root filesystem, 1-3
- login:
 - command file, default, 1-13
 - directory, 1-13
 - message, changing, 1-16
 - shell, 1-14
- lost+found directory, 3-26
 - lack of, 3-25
- low bank of memory, 6-4
- LSI-11/23 processor, 4-6
 - jumpers and straps, 6-2
 - socket locations, 5-13
- LSI-11/73 processor, 4-6
 - jumpers and straps, 6-3
 - socket and straps, 5-14

M

- magnetic tape capacities, 3-9
- Main Interconnect board, 4-6
- maintenance access, 5-4
- making a filesystem, 1-23, 3-14 thru 3-17
- mass storage, 4-7
- memory bank selection, 6-4

memory boards, 6-4
 256K and 512K, 6-4 thru 6-7
 jumpers and straps, 6-5 thru 6-7
 memory parity error, 1-33
 message of the day file, 1-16
 messages, sending to all users, 1-16
 Micropolis 1304 Hard Disk Drive, jumpers, 6-12
 misaligned directory, 3-23
 mkboot command, 1-29, 3-14
 mkfs command, 1-23, 1-27, 3-14 thru 3-17
 mkggroup command, 1-12
 mkuser command, 1-13
 MODE SELECT switch, 2-8 thru 2-10
 modem:
 with 8540, 2-7
 with 8550, 2-10
 with 8560, 2-10
 modifying. *See* changing
 mount command, 1-5, 1-7, 1-28
 mounting filesystems, 1-16
 MSC Controller Board, 6-8
 multi-user mode, 1-10

N

newproc, TNIX internal routine, 1-30
 non-root filesystems, 1-3
 restoring backups to, 1-27
 notational conventions, 1-2
 nswap, cvt parameter, 1-25, 1-30

O

obtaining a system (core) dump, 1-33
 ODT microcode, console, 1-33
 operating mode, changing, 1-10 thru 1-11
 operating modes, system, 1-10
 orphan files, 3-23, 3-24
 OS/40, 4-5
 out of bounds blocks, 3-24

P

page register, 1-31
 panic messages, 1-30 thru 1-33
 parameters, cvt, 1-25, 3-3
 parameters, mkfs, 1-23, 1-27, 3-14
 passwd command, 1-3, 1-14
 passwords, assigning, deleting, modifying, 1-3, 1-14
 periodic backups, 1-19 thru 1-23
 permstr command, 2-6
 pipe device, major and minor numbers, 3-5
 pipedev, cvt parameter, 1-25, 3-5

ports, 2-1 thru 2-3
 8540 terminal configuration, B-4
 configuring, 2-1
 HSI, 2-1 thru 2-2, B-2 thru B-3
 initializing, 2-3
 interface signal connections, Appendix C
 line printer, 2-11
 normal configuration, 2-1
 numbers of, 2-2
 power:
 consumption, B-1
 cord receptacle, A-3
 failure, 1-32
 requirements, 5-6
 supply specification, B-1
 powering down the 8560, 1-7
 powering up the 8560, 1-4 thru 1-6, 7-3
 preposterous cvt address, 3-7
 primary voltage, selecting the proper, 5-11, A-4
 process table size, changing, 3-5
 Processor Busy indicator, A-2
 processor status word, 1-31
 processor jumpers and straps, 6-2 thru 6-3
 profile file, 1-13
 program counter contents, 1-31
 program status word, 1-31

Q

Q-bus, 4-6
 QumeTrak 242 Flexible Disk Drive, jumpers, 6-10

R

RAM boards, 6-4 thru 6-7
 rear panel controls and indicators, A-2 thru A-4
 reboot, from fixed disk, 1-6
 Record Sheet, Filesystem Configuration, 3-15
 reconfiguring TNIX for additional users, 7-7
 recovering files from backups, 1-21 thru 1-28, 3-18 thru 3-20
 recovering from a system crash, 1-29
 recursive system call during system crash, 1-32
 removing a user's account, 1-13
 removing passwords, 1-15
 reinitializing TNIX, 1-23
 REMOTE BAUD switch, 2-9, 2-10
 reshipment, 5-15
 RESTART switch, A-2
 restor command, 1-24, 1-28, 3-12, 3-18 thru 3-20
 restoring backups, 1-21 thru 1-28, 3-18 thru 3-20
 algorithm for, 1-25
 to a non-root filesystem, 1-27 thru 1-28
 to the root filesystem, 1-23 thru 1-27

- restoring the root filesystem, 1-23 thru 1-27
- root account, 1-3
- root device parameters, 3-5
- root directory, 1-3
- root filesystems, 1-3, 3-14 thru 3-17
 - logical device names, 1-3
 - restoring backups to, 1-23 thru 1-27
- rootdev, cvt parameter, 1-25
- RUN/HALT switch, A-2

S

- safety summary, ix
- script, configuration of cvt, 3-3
- Seagate ST419 Hard Disk Drive shunt, 6-11
- segmentation violation, 1-33
- selecting baud rate, 2-3
- sending messages to all users, 1-16
- shipping, 5-15
- shutdown command, 1-7
- shutting down the system, 1-7
- single-user mode, 1-10
- signal connections, commonly used, Appendix C
- site preparation, 5-1 thru 5-6
- size parameters, kernel, 3-4 thru 3-5
- step TNIX internal routine, 1-31
- stepping, 1-31
- slp command, 2-13
- space requirements of 8560, 5-2
- special files, 3-19
- specifications, Appendix B
- standalone mode, 1-10
- standalone syschk, 1-29
- starting the system, 1-4 thru 1-5
- STARTUP string, 2-6, 2-7
- storing the 8560, 5-15
- Straps. *See* Jumpers
- superblock, bad, 3-23
- superuser account, 1-3
- swap:
 - device, major and minor numbers, 3-5
 - map entries, changing the number of, 1-30, 3-5
 - parameters, 3-6
 - space, 1-31, 3-6
- swapdev, cvt parameter, 1-25, 3-5
- switches:
 - DC ON/OFF, A-2
 - front panel, A-1
 - MODE SELECT, 2-9, 2-10
 - PRIMARY VOLTAGE selector, A-4
 - rear panel, A-2
 - REMOTE BAUD, 2-9 thru 2-10
 - RESTART, A-2
 - RUN/HALT, A-2
- swplo, cvt parameter, 1-25, 1-31, 3-6
- syschk command, 1-5, 1-25, 1-29, 3-21 thru 3-26

- system:
 - backups, 1-17 thru 1-28, 3-8
 - crash, causes and recovery from, 1-29 thru 1-33
 - crash messages, 1-30 thru 1-33
 - date, 1-6, 3-6
 - dump, 1-33
 - installation overview, Section 4
 - maintenance commands, Section 3
 - manager, 1-1
 - manager account, 1-3
 - memory, 4-6
 - operating modes, 1-8 thru 1-11
 - power-up procedure, 7-3
 - shut down, 1-7
 - start up, 1-4 thru 1-5
 - time, 1-6
 - verification, 7-3 thru 7-7

T

- tape capacities, 3-9
- tapes, reading backup data from, 3-18 thru 3-20
- TERM mode, 2-5, 2-8, 2-9
- TERMINAL connector (J104), 2-9 thru 2-10
- terminal, connecting, 2-4, 7-1 thru 7-2
- text table entries, changing the number of, 3-5
- time, system, 1-6, 3-6
- time zone, setting, 3-6
- TNIX panic messages, 1-30 thru 1-33
- trace bit, 1-32
- trap, TNIX panic messages, 1-31 thru 1-33
- turning off the system, 1-7
- turning on the system, 1-4 thru 1-6, 7-3

U

- umount command, 1-11, 1-17
- unimplemented opcode, 1-32
- unmounting filesystems, 1-7, 1-17, 1-27
- unpacking, 5-7 thru 5-14
- user ID, 1-14
- users:
 - assigning to a group, 1-13
 - creating new accounts for, 1-13
 - deleting accounts for, 1-13
 - increasing system capacity, 7-7
 - information in /etc/passwd file, 1-14
- Utility Board, 6-13

V

- variable baud rate, 2-3
- verifying the system, 7-3 thru 7-7
- voltage, input, 5-11, B-1

- W**
- wall command, 1-16
 - who command, 1-12
- X**
- Xebec Disk Controller Board jumpers, 6-9

MANUAL CHANGE INFORMATION

At Tektronix, we continually strive to keep up with latest electronic developments by adding circuit and component improvements to our instruments as soon as they are developed and tested.

Sometimes, due to printing and shipping requirements, we can't get these changes immediately into printed manuals. Hence, your manual may contain new change information on following pages.

A single change may affect several sections. Since the change information sheets are carried in the manual until all changes are permanently entered, some duplication may occur. If no such change pages appear following this page, your manual is correct as printed.

Date: February 1, 1985 Change Reference: C1/285

Product: 8560 Series: System Manager's Guide-V2.1 Manual Part No.: 070-5050-00

DESCRIPTION

Product Group 61

The 512K Memory Board is now standard on 8560 Multi-User Software Development Units. (Mod # MDP 937).

CHANGE INSTRUCTIONS

Throughout this manual, change all references to the 256K Memory Board as standard configuration for the 8560 MUSDU, to read 512K Memory Board as standard.