

AV-C971B-TA

WORD PROCESSING SYSTEM

Reference Manual

**WPS-8 Word Processing System
Reference Manual
(Versions 2.7 and 3.0)**

Copyright © 1978 by Digital Equipment Corporation

The information in this document is subject to change without notice and should not be construed as a commitment by Digital Equipment Corporation. Digital Equipment Corporation assumes no responsibility for any errors that may appear in this document.

The software described in this document is furnished under a license and may not be used or copied except in accordance with the terms of such license.

Digital Equipment Corporation assumes no responsibility for the use or reliability of its software on equipment that is not supplied by DIGITAL.

Printed in U.S.A.

This document was typeset on DIGITAL's
DECset-8000 computerized typesetting system.

The following are trademarks of Digital Equipment Corporation:

COMPUTER LABS	DIBOL	OS/8
COMTEX	DIGITAL	PDP
DDT	EDUSYSTEM	PHA
DEC	FLIP CHIP	RSTS
DECCOMM	FOCAL	RSX
DECsystem-10	INDAC	TYPESET-8
DECSYSTEM-20	LAB-8	TYPESET-10
DECtape	MASSBUS	TYPESET-11
DECUS	OMNIBUS	UNIBUS

CONTENTS

Page

PREFACE

CHAPTER 1 INTRODUCTION

1.1	WORD PROCESSING EQUIPMENT.....	1-3
1.1.1	The Keyboard	1-7
1.1.2	The Display Screen.....	1-9
1.1.3	Storage.....	1-10
1.1.4	Printers	1-12
1.2	USING THE WORD PROCESSING SYSTEM	1-12

CHAPTER 2 OPERATING THE WS78 EQUIPMENT

2.1	TURNING ON THE MACHINE	2-1
2.2	INSERTING THE DISKETTES	2-4
2.3	BOOTSTRAPPING	2-7
2.4	TYPING THE DATE AND TIME	2-10
2.5	MAIN MENU	2-10
2.6	RESETTING THE DATE AND TIME	2-12
2.7	STOPPING.....	2-12
2.8	POWER FAILURES AND BROWN-OUTS.....	2-13

CHAPTER 2 OPERATING THE WS100 EQUIPMENT

2.1	TURNING ON THE MACHINE	2-1
2.2	BOOTSTRAPPING	2-4
2.3	INSERTING THE DISKETTES	2-5
2.4	TYPING THE DATE AND TIME	2-8
2.5	MAIN MENU	2-11
2.6	RESETTING THE DATE AND TIME	2-12
2.7	STOPPING.....	2-13
2.8	POWER FAILURES AND BROWN-OUTS.....	2-13

CONTENTS (CONT.)

CHAPTER 2 OPERATING THE WS102 AND WS202 EQUIPMENT

2.1	TURNING ON THE MACHINE.....	2-2
2.2	BOOTSTRAPPING.....	2-6
2.3	INSERTING THE DISKETTES.....	2-9
2.4	START MENU.....	2-12
2.5	TYPING THE DATE AND TIME.....	2-15
2.6	MAIN MENU.....	2-17
2.7	RESETTING THE DATE AND TIME.....	2-18
2.8	STOPPING.....	2-19
2.9	POWER FAILURES AND BROWN -OUTS.....	2-19

CHAPTER 3 CREATING A DOCUMENT

3.1	HOW TO CREATE A DOCUMENT.....	3-1
3.1.1	Naming a Document.....	3-3
3.1.1.1	Correcting a Typo in the Document Name.....	3-3
3.1.1.2	Document Storage Location.....	3-3
3.1.2	Screen Display When a Document Is Created.....	3-4
3.2	TYPING NEW TEXT.....	3-5
3.2.1	Ending Lines: Word Wrap Versus Hard Return.....	3-6
3.2.2	Removing Errors Just Typed.....	3-7
3.2.3	Leaving Vertical Space for Insertions.....	3-7
3.2.4	Centering, Underlining, and Boldfacing.....	3-8
3.2.5	Problem: Running Out of Storage Space While Typing.....	3-8
3.3	FILING A DOCUMENT.....	3-8

CHAPTER 4 DOCUMENT INDEX

4.1	EXAMINING THE INDEX.....	4-1
4.2	USING THE INDEX.....	4-3
4.3	PRINTING THE INDEX.....	4-4
4.4	DOCUMENT NUMBER ONE: CHANGING THE SPELLING OF A DOCUMENT NAME.....	4-7

CONTENTS (CONT.)

CHAPTER 5 EDITING A DOCUMENT

5.1	BRINGING AN EXISTING DOCUMENT TO THE SCREEN	5-2
5.1.1	Identifying a Document To Be Edited	5-3
5.1.1.1	Document Storage Location	5-4
5.1.1.2	Using the Index To Identify A Document	5-4
5.1.2	Screen Display	5-6
5.1.3	Getting an Extra Version of an Existing Document	5-7
5.2	MOVING THE CURSOR	5-8
5.2.1	Using the Mini Keyboard Grammatical Keys	5-9
5.2.2	Using the ADVANCE and BACK UP Keys To Scroll	5-10
5.2.3	Using the Gold TOP and BOT DOCMT Keys	5-11
5.3	INSERTING ADDITIONAL TEXT	5-12
5.4	MAKING CHANGES	5-12
5.4.1	Interchanging Two Characters	5-12
5.4.2	Deleting a Character or Word	5-13
5.4.3	Cutting: Deleting a Portion of Text	5-14
5.4.4	Cutting and Pasting	5-15
5.4.4.1	Preserving Rulers When Pasting	5-16
5.4.4.2	Summary of Different Cutting and Pasting Key Combinations	5-18

CHAPTER 6 RULERS

6.1	USING A RULER	6-2
6.1.1	Displaying a Ruler	6-3
6.1.2	Making Ruler Settings	6-5
6.1.2.1	Left Margin and Vertical Line Spacing	6-6
6.1.2.2	Right Margin	6-8
6.1.2.3	Paragraph Indent	6-9
6.1.2.4	Automatic Word Wrap Indent	6-11
6.1.2.5	Tabs	6-12
6.1.2.6	Incorrect Settings	6-16
6.1.3	Clearing a Ruler Display	6-16
6.2	CHANGING RULERS IN TYPED TEXT	6-16
6.3	USING A WIDE RULER	6-17
6.4	SAVING RULERS FOR REUSE	6-20
6.5	CHANGING AN UNDESIRED RULER	6-21

CONTENTS (CONT.)

CHAPTER 7 SEARCHING

7.1	BASIC AND CONTINUED SEARCHING	7-2
7.1.1	Searching Qualifications.....	7-3
7.1.2	Direction Reversal.....	7-3
7.2	SEARCHING AND REPLACING	7-3

CHAPTER 8 HIGHLIGHTING TEXT: CENTERING, UNDERLINING, BOLDFACING, AND CAPITALIZATION

8.1	CENTERING	8-2
8.1.1	Changing the Centering Point	8-4
8.1.2	Determining Whether Text Is Centered	8-5
8.2	UNDERLINING AND BOLDFACING	8-6
8.2.1	Underlining or Boldfacing While Typing.....	8-6
8.2.2	Underlining or Boldfacing After Typing	8-7
8.2.3	Determining Whether Text Is Underlined Or Boldfaced	8-8
8.2.4	Effect of Spaces on Underlining	8-8
8.2.4.1	Underlining Words and Spaces	8-8
8.2.4.2	Underlining Only Words.....	8-9
8.2.4.3	Effect of Right Margin On Underlining	8-9
8.3	CAPITALIZATION	8-11
8.4	REMOVING UNDERLINING, BOLDFACING AND CAPITALIZATION	8-12

CHAPTER 9 SUBSCRIPTS, SUPERSCRIPTS, AND COMPOSITE CHARACTERS

9.1	SUBSCRIPTS AND SUPERSCRIPTS.....	9-1
9.1.1	Producing Subscripts and Superscripts with the Gold SUB SCRIPT and SUPER SCRIPT Keys	9-2
9.1.1.1	Removing a Subscript or Superscript	9-4
9.1.1.2	Qualifications	9-4
9.1.2	Producing Subscripts and Superscripts with Half-line Ruler Spacing.....	9-4
9.2	COMPOSITE CHARACTERS.....	9-10

CONTENTS (CONT.)

CHAPTER 10 REUSABLE TEXT: LIBRARY DOCUMENTS

10.1	CREATING A LIBRARY ENTRY	10-2
10.1.1	Creating an Abbreviation Entry	10-2
10.1.2	Creating a Paragraph Entry	10-3
10.2	USING AN ABBREVIATION OR PARAGRAPH ENTRY	10-4
10.3	INCLUDING A RULER IN AN ABBREVIATION OR PARAGRAPH ENTRY.....	10-5
10.4	QUALIFICATIONS	10-6
10.5	NONSTANDARD ABBREVIATIONS AND PARAGRAPH DOCUMENTS	10-7

CHAPTER 11 HYPHENATION

11.1	COMPOUND WORDS.....	11-2
11.2	HYPHENATING TYPED TEXT BY PUSHING AND PULLING...	11-3
11.3	USING INVISIBLE HYPHENS.....	11-6
11.4	EXAMINING TEXT FOR BREAKING AND INVISIBLE HYPHENS	11-7
11.5	IMPROVING RIGHT MARGIN APPEARANCE BY HYPHENATION ZONE	11-7
11.5.1	Using a Hyphenation Zone When Typing or Editing.....	11-8
11.5.2	Using a Hyphenation Zone When Paginating	11-10

CHAPTER 12 PAGINATION

12.1	AUTOMATIC PAGINATION	12-1
12.2	FORCING PAGE ENDINGS	12-2
12.3	DISPLAYING AND MODIFYING PAGE ENDINGS	12-4
12.3.1	Changing PAGE MARKERS.....	12-7
12.3.2	Qualifications: Automatic Removal of PAGE MARKERS	12-7
12.3.3	Qualification: Word Wrapping	12-7
12.4	CHANGING THE NUMBER OF LINES PER PAGE.....	12-8

CONTENTS (CONT.)

CHAPTER 13 PRINTING A DOCUMENT

13.1	IDENTIFYING A DOCUMENT TO BE PRINTED	13-2
13.2	PRINT MENU	13-3
13.3	CHANGING PRINT MENU SETTINGS	13-7
13.3.1	Specifying Pagination	13-12
13.3.2	Specifying a Top Margin and Bottom Margin	13-12
13.3.3.	Multiple Column Printing	13-15
13.3.3.1	Space Between Multiple Columns	13-17
13.3.3.2	Effect of Rulers	13-19
13.3.3.3	Advancing to New Columns and Pages	13-20
13.3.3.4	Printing Multiple Columns of Unequal Length	13-22
13.3.3.5	Qualifications	13-24
13.3.4	Specifying the Number of Copies To Be Printed	13-25
13.3.5	Specifying the Document Destination	13-25
13.3.6	Adding Extra Vertical Space	13-25
13.3.7	Specifying the First and Last Pages To Be Printed and the Number To Appear on the First Page	13-26
13.3.8	Specifying the Pitch	13-28
13.3.8.1	Proportional Spacing	13-29
13.3.8.2	Qualifications	13-29
13.3.9	Adding Extra Space in the Left Margin	13-30
13.3.10	Specifying the Physical Page Size	13-31
13.3.11	Using Extra Print Wheel Characters (Version 3.0 only)	13-31
13.3.12	Saving and Retrieving Print Menu Settings	13-31
13.3.13	Stopping the Printer To Insert Special Paper	13-32
13.3.14	Using Two Different Styles of Type	13-33
13.4	CHECKING OUT THE PRINTER	13-34
13.5	INTERRUPTING PRINTING	13-35
13.6	WHEN PRINTING FAILS TO START	13-37
13.7	PRINTING DOCUMENTS ON ANOTHER SYSTEM	13-39
13.7.1	Saving a List of Documents to Be Printed on Another System	13-39
13.7.2	Printing Documents from a Saved List	13-41
13.7.3	Qualifications	13-41

CHAPTER 14 HEADERS AND FOOTERS

14.1	CREATING A HEADER OR FOOTER	14-2
14.2	CHANGING A HEADER OR FOOTER	14-4
14.3	PRINTING THE DATE AND PAGE NUMBERS	14-5
14.4	RESETTING PAGE NUMBERS	14-6
14.5	HEADER AND FOOTER POSITIONING ON A PAGE	14-6

CONTENTS (CONT)

14.6	QUALIFICATIONS: EFFECT OF RULER	14-9
14.7	EFFECT OF ADDING EXTRA VERTICAL SPACE WHEN PRINTING	14-10
CHAPTER 15 USER DEFINED KEYS		
15.1	CREATING A USER DEFINED KEY	15-1
15.2	USING A USER DEFINED KEY	15-5
15.3	CHANGING A USER DEFINED KEY	15-5
15.4	RESTRICTIONS	15-6
15.5	INCLUDING ONE USER DEFINED KEY WITHIN ANOTHER.	15-6
CHAPTER 16 CUSTOMIZING		
16.1	COMMENTS	16-1
16.2	DATE AND TIME STAMP	16-3
16.3	CUSTOMIZATION POINTS	16-3
16.4	LIST PROCESSING	16-4
16.4.1	Summary of Features	16-6
16.4.2	Using List Processing	16-9
CHAPTER 17 MAINTAINING DISKETTES		
17.1	DELETING A DOCUMENT	17-2
17.2	INITIALIZING, VERIFYING, AND COPYING DISKETTES	17-4
17.2.1	Initializing a Document Diskette	17-5
17.2.2	Initializing a System Diskette	17-6
17.2.3	Verifying a Diskette	17-6
17.2.3.1	How to Verify a Diskette	17-7
17.2.3.2	Recovering from Diskette Errors	17-10
17.2.3.3	Preventing Diskette Problems	17-11
17.2.4	Copying a Diskette	17-13

CONTENTS (CONT.)

CHAPTER 18 WS102 AND WS202 SPECIAL FEATURES

18.1	SHARING THE SAME SCREEN.....	18-3
18.2	ORDER IN WHICH DOCUMENTS ARE PRINTED	18-3

APPENDIX A WORD PROCESSING KEYS

A.1	THE MAIN KEYBOARD.....	A-2
A.2	THE MINI KEYBOARD.....	A-8

APPENDIX B MAIN MENU OPTIONS

APPENDIX C USING SYSTEMS THAT HAVE FOUR DISKETTE DRIVES

C.1	REFERENCING A DOCUMENT	C-3
C.2	USING THE DISKETTE INDEX	C-4

APPENDIX D VIEWING TEXT

APPENDIX E RULER SETTING CHARACTERS

APPENDIX F HOW NONTEXT KEYSTROKES ARE DISPLAYED WHEN TYPED INTO A USER DEFINED KEY

APPENDIX G USING THE WS78 AUXILIARY COMMUNICATIONS PORT

GLOSSARY

INDEX

FIGURES

Figure No.	Title	Page
1-1	Display Screen	1-1
1-2	WS78	1-3
1-3	WS100	1-4
1-4a	WS102	1-5
1-4b	WS202	1-6
1-5	Keyboards	1-7
1-6	Example of Main Keyboard	1-8
1-7	Mini Keyboard	1-9
1-8	Diskette	1-10
1-9	Document Index	1-11
1-10	Printers	1-12
1-11	Main Menu (Versions 2.7 and 3.0)	1-13
1-12	Print Menu (Version 2.7)	1-14
	Print Menu (Version 3.0)	1-15
1-13	Example of Prompt	1-15
1-14	Example of Error Message	1-16
	WS78:	
2-1	WS78 Display Screen ON/OFF Switch	2-2
2-2	WS78 Terminal ON/OFF Switch	2-3
2-3	Diskette	2-4
2-4	Inserting System Diskette in Drive	2-5
2-5	Inserting Document Diskette in Drive	2-6
2-6	WS78 START Switch	2-7
2-7	WS78 Date/Time Menu	2-8
2-8	WS78 Intensity Control Switch	2-9
2-9	Main Menu Page One (Versions 2.7 and 3.0)	2-11
2-10	Finished Message	2-12
	WS100:	
2-1	WS100 Display Screen Switch	2-2
2-2	WS100 ON/OFF Switch	2-3
2-3	WS100 START Switch	2-4
2-4	Diskette	2-5
2-5	Inserting System Diskette in Drive	2-6
2-6	Inserting Document Diskette in Drive	2-7
2-7	WS100 Date/Time Menu	2-8
2-8	WS100 Intensity Control Switch	2-10
2-9	Main Menu Page One (Version 2.7)	2-11
	Main Menu Page One (Version 3.0)	2-12

FIGURES (Cont)

Figure No.	Title	Page
2-10	Finished Message	2-13
	WS102/202:	
2-1	WS102 Display Screen Switch.....	2-2
2-2a	WS102 ON/OFF Switch.....	2-4
2-2b	WS202 ON/OFF Switch.....	2-5
2-3a	WS102 Start Switch.....	2-7
2-3b	WS202 START Switch.....	2-8
2-4	Diskette.....	2-9
2-5	Inserting System Diskette in Drive	2-10
2-6	Inserting Document Diskette in Drive.....	2-11
2-7a	WS102 Start Menu.....	2-12
2-7b	WS202 Start Menu.....	2-13
2-8	WS102 Intensity Control Switch.....	2-14
2-9	WS102 Date/Time Menu (Version 2.7).....	2-15
	WS102 Date/Time Menu (Version 3.0).....	2-16
2-10	Main Menu Page One (Version 2.7).....	2-17
	Main Menu Page One (Version 3.0).....	2-18
2-11	Finished Message	2-19
3-1	Document Create Prompt.....	3-2
3-2	Document Name Example.....	3-3
3-3	Example of Screen Display When Creating a Document	3-4
3-4	Viewed Text Showing Word Wrap and Hard Carriage Return	3-6
3-5	Main Keyboard RUB WORD OUT, RUB SENT, RUB CHAR OUT, RUB LINE Keys.....	3-7
3-6	Main Keyboard FILE DOCMT Key	3-8
4-1	Document Index Example	4-2
4-2	Copy Index Prompt.....	4-4
4-3	Example of Specifying Index Document.....	4-5
4-4	Prompt for Modifying an Existing Index Document.....	4-6
4-5	Example of Document One.....	4-7
5-1	Document Edit Prompt (1)	5-2
5-2	Document Edit Prompt (2)	5-3
5-3	Using the Document Index to Indicate Document to Be Edited (1)	5-4
5-4	Using the Document Index to Indicate Document to Be Edited (2)	5-5
5-5	Example of Screen Display When a Document Is Specified for Editing	5-6
5-6	Main Keyboard GET DOCMT Key.....	5-8
5-7	Mini Keyboard ADVANCE and BACK UP Keys	5-9
5-8	Main Keyboard TOP DOCMT and BOT DOCMT Keys	5-11
5-9	Mini Keyboard DEL WORD and DEL CHAR Keys.....	5-13
5-10	Mini Keyboard SEL and CUT Keys.....	5-14

FIGURES (Cont)

Figure No.	Title	Page
5-11	Mini Keyboard PASTE and CUT Keys.....	5-15
5-12	Example of Cutting and Pasting Using the Mini Keyboard CUT and PASTE Keys.....	5-16
5-13	Example of Cutting and Pasting Using the CUT and GOLD Plus PASTE Keys..	5-17
5-14	Ruler Used as a Result of Different Removal and Replacement Methods	5-18
6-1	Example of Rulers.....	6-2
6-2	Main Keyboard RULER Key.....	6-3
6-3	Example of Displayed Ruler	6-4
6-4	Example of Different Left Margin Ruler Settings	6-7
6-5	Main Keyboard PARA MARKER Key.....	6-9
6-6	Example of Paragraph Indent	6-10
6-7	Example of Word Wrap Indent	6-11
6-8	Example of Left-Justified, Right-Justified, and Decimal-Aligned Tabs.....	6-13
6-9	Example of Using the Right Margin as a Tab	6-14
6-10	Example of Viewing Tabbed Text	6-15
6-11	Example of Wide Ruler	6-17
6-12	Displayed Example of Text Typed with Wide Ruler in Effect.....	6-18
6-13	Printed Example of Text Typed with Wide Ruler in Effect	6-19
6-14	Example of Text Before Pasting.....	6-21
6-15	Reformatted Example of Text After Pasting	6-22
7-1	Main Keyboard SRCH, CONT SRCH, CONT SRCH and SEL Keys.....	7-2
8-1	Main Keyboard CENTR Key.....	8-2
8-2	Example of Centering Text	8-3
8-3	Example of a User-Specified Centering Point	8-4
8-4	Example of Viewing Centered Text	8-5
8-5	Mini Keyboard BOLD and UNDERLINE Keys.....	8-6
8-6	Example of Viewing Underlined and Boldfaced Text.....	8-8
8-7	Main Keyboard SHIFT and CAPS LOCK Keys, Mini Keyboard SEL and UPPER CASE Keys	8-11
8-8	Example of Changing Uppercase Text to Lowercase.....	8-12
9-1	Main Keyboard SUB SCRIPT and SUPER SCRIPT Keys.....	9-2
9-2	Example of Viewing Subscripts and Superscripts	9-3
9-3	Typing an Example Equation: Step 1	9-5
9-4	Typing an Example Equation: Step 2	9-6
9-5	Typing an Example Equation: Step 3	9-7
9-6	Typing an Example Equation: Step 4	9-8
9-7	Typing an Example Equation: Final Results	9-9
9-8	Main Keyboard DEAD Keys.....	9-10
9-9	Example of Typing Composite Characters.....	9-11

FIGURES (Cont)

Figure No.	Title	Page
10-1	Main Keyboard LIBRY and ABBRV Keys	10-4
10-2	Example of Inserting Ruler in Abbreviation Library Entry	10-5
10-3	Example of Text After Abbreviation Library Entry Which Includes Ruler Is Inserted	10-6
10-4	Editor Menu Showing Standard Abbreviation and Paragraph Library Documents.	10-8
10-5	Example of Editor Menu Showing User-Supplied Abbreviation and Paragraph Library Documents	10-9
11-1	Main Keyboard PRINT HYPH Key	11-2
11-2	Main Keyboard HYPH PUSH and HYPH PULL Keys	11-3
11-3	Main Keyboard SHIFT and PRINT HYPH Keys	11-6
11-4	Example of Viewing Text for Breaking, Nonbreaking, and Invisible Hyphens	11-7
11-5	Example of Using a Hyphenation Zone	11-9
12-1	Main Keyboard NEW PAGE Key	12-2
12-2	Example of Using a NEW PAGE Mark	12-3
12-3	Main Keyboard PAGE MARKER Key and Mini Keyboard PAGE Key ...	12-4
12-4	Example of a PAGE MARKER Inserted by the Word Processing System ...	12-5
12-5	Example of Page Ending Which Could Be Improved	12-6
12-6	Editor Menu Showing System-Supplied Text Sizes	12-8
12-7	Editor Menu Showing User-Supplied Text Sizes	12-9
12-8	Relationship of Editor and Print Menu Settings for Page Size	12-10
13-1	Printing Request Prompt	13-2
13-2	Example of Print Menu Page One (Version 2.7)	13-3
	Example of Print Menu Page One (Version 3.0)	13-4
13-3	Example of Print Menu Page Two (Versions 2.7 and 3.0)	13-5
13-4	Example of Print Menu Page Three	13-6
13-5	Relationship of Editor and Print Menu Settings for Page Size	13-13
13-6	Example of Two-Column Printed Text	13-15
13-7	Example of Typing Two-Column Text	13-16
13-8	Example of Two Column Text Separated by Two Spaces	13-17
13-9	Example of Specifying Different Widths in Multiple Columns	13-18
13-10	Example of Ruler Use with Multiple Columns	13-19
13-11	Example of Starting Multiple Column Text on a New Page	13-21
13-12	Example of a Complicated Multiple Column Table Produced by Word Processing ...	13-22
13-13	Example of Order in Which a Multiple Column Complicated Table Was Typed	13-23
13-14	Example of Screen Display for Typing a Multiple Column Complicated Table	13-24
13-15	Example of Printing the Third Stored Page as Number 23	13-27
13-16	Example of Using Ten-Pitch Letter Quality Printer Print Wheel	13-28
13-17	Example of Using Twelve-Pitch Letter Quality Printer Print Wheel	13-28

FIGURES (Cont)

Figure No.	Title	Page
13-18	Example of Using a Ten-Pitch Print Wheel with a Twelve-Pitch Setting.	13-28
13-19	Example of Proportional Printing	13-29
13-20	Example of Adding Space in the Left Margin of a Printed Page.....	13-30
13-21	Example of Two-Typeface Text After Being Printed with the First Print Wheel.....	13-33
13-22	Example of Two-Typeface Text After Being Printed with Both Print Wheels	13-33
13-23	Stop Printer Menu	13-35
13-24	Prompt for Saving a List of Documents to Be Printed.....	13-39
13-25	Prompt for Modifying an Existing Printing List.....	13-40
13-26	Prompt for Printing Documents from a Saved List.....	13-41
14-1	Example of Headers and Footers	14-1
14-2	Main Keyboard CMND Key	14-2
14-3	Screen Display Showing a Header	14-3
14-4	Screen Display Showing a Footer, Page Numbering Request, and Date Request	14-5
14-5	Header Positioning Within Top Margin; Footer Positioning Within Bottom Margin	14-7
14-6	Relationship of Editor and Print Menu Settings for Page Size	14-8
14-7	Example of Printed Header and Text When Extra Vertical Space is Specified	14-10
15-1	Prompt for Defining a User Defined Key.....	15-2
15-2	Screen Display for Typing a User Defined Key	15-3
15-3	Example of a User Defined Key Displayed on the Screen.....	15-4
16-1	Example of a Comment	16-1
16-2	Main Keyboard CMND Key	16-2
16-3	Main Keyboard DATE + TIME Key	16-3
16-4	Example of Form Letters Produced by List Processing	16-5
16-5	Example of Customized Letter Produced by List Processing	16-7
16-6	List Processing Selection/Merging/Printing Production.....	16-9
17-1	Document Deletion Prompt.....	17-2
17-2	Deletion Confirmation Prompt.....	17-3
17-3	Diskette Maintenance Menu	17-4
17-4	Diskette Initialization Prompt.....	17-5
17-5	Diskette Verification Prompt	17-7
17-6	Example of Diskette Verification Screen Display for a Diskette Without Errors	17-8
17-7	Example of Diskette Verification Screen Display for a Diskette Having Errors	17-9
17-8	Diskette Verification Prompt	17-10
17-9	Diskette Copy Prompt.....	17-13
17-10	Prompt Displayed at Completion of Diskette Copy	17-14
18-1	WS102 Main Menu Page (Versions 2.7 and 3.0).....	18-2
18-2	Example of Document Printing Order: Both Users Set SP to YES	18-4
18-3	Example of Document Printing Order: Both Users Set SP to NO	18-5
18-4	Example of Document Printing Order: One User Sets SP to YES, Other to NO (1)...	18-5
18-5	Example of Document Printing Order: One User Sets SP to YES, Other to NO (2)...	18-6

FIGURES (Cont)

Figure No.	Title	Page
A-1	Word Processing Main and Mini Keyboards.....	A-1
A-2	Main Keyboard.....	A-2
A-3	Mini Keyboard.....	A-8
B-1	Main Menu Page One (Version 2.7).....	B-1
	Main Menu Page One (Version 3.0).....	B-2
B-2	Main Menu Page Two (Versions 2.7 and 3.0).....	B-3
B-3	Main Menu Page Three (Version 2.7).....	B-4
	Main Menu Page Three (Version 3.0).....	B-5
B-4	Main Menu Page Four (Versions 2.7 and 3.0).....	B-6
B-5	Main Menu Page Four (Versions 2.7 and 3.0).....	B-6
B-5	Main Menu Page Five (Version 2.7) (WS102 and WS202 Systems Only).....	B-7
	Main Menu Page Five (Version 3.0).....	B-8
C-1	Four Diskette Drives.....	C-2
D-1	Main Keyboard VIEW Key.....	D-1
G-1	Systems Options Menu.....	G-1
G-2	Communications Settings Menu.....	G-2

TABLES

Table No.	Title	Page
13-1	Print Menu Settings.....	13-8
13-2	Stop Printer Menu Options.....	13-36
A-1	Main Keyboard Keys.....	A-3
A-2	Mini Keyboard Blue Keys.....	A-10
A-3	Mini Keyboard White Keys.....	A-11
A-4	Mini Keyboard Red Keys.....	A-13
A-5	Mini Keyboard Black Keys.....	A-13
D-1	Viewing Symbols.....	D-2
E-1	Summary of Ruler Setting Characters.....	E-1

PREFACE

The *Word Processing System Reference Manual* explains how to use Digital Equipment Corporation's word processing systems. It provides complete information for every word processing feature, with examples such as what you'll see on the display screen or the results of giving an incorrect response. The manual has been specially designed and formatted so that you can readily see the basic steps to perform an operation, if that's all you need.

This manual has been written for anyone who has access to a DIGITAL word processing system – typists, programmers, engineers, lawyers, doctors, dentists. The only prerequisite knowl-

edge is the ability to use an office-grade or portable typewriter.

To use this manual most effectively, inspect the Index for references to the pages where particular features are described. If you would like to read the entire manual but your time is limited, use the following guide to selective reading.

Because you start each DIGITAL word processing system model by a slightly different procedure, there is a separate Chapter 2 for each. Read the Chapter 2 that applies to the model you have available.

Application

Learning enough information to become productive

Typing and making changes

Laying out words on a page, both horizontally and vertically

Printing what was typed

Maintaining stored text

Learning more advanced features

Chapters to Read

1 Introduction
2 Operating the Equipment
3 Creating a Document
5 Editing a Document
13 Printing a Document
17 Maintaining Diskettes
Glossary

3 Creating a Document
5 Editing a Document
7 Searching
8 Highlighting Text: Centering, Underlining, Boldfacing, and Capitalization
9 Subscripts, Superscripts, and Composite Characters

6 Rulers
12 Pagination
14 Headers and Footers

13 Printing a Document
14 Headers and Footers

4 Document Index
17 Maintaining Diskettes

10 Reusable Text: Library Documents
15 User Defined Keys
16 Customizing
18 WS102 and WS202 Special Features

This manual is organized as follows:

- *Overviews of the subject matter* are located at the beginning of each chapter. These describe the different tasks you can accomplish and provide forward references (within the same chapter) to the detailed information.
- *Operating instructions* are listed in the order you should follow. Upper case letters are used in describing responses you may type to the word processing system. In most cases, however, you may type either upper or lower case letters. The manual points out when only upper or only lower case is required.
- *Drawings of the keyboards* show the location of the keys you should press while following the instructions.
- *Photographs of actual screen displays* show the information that will appear on the word processing display screen as you follow the instructions.
- *Appendixes*, located after the last chapter, provide information additional to the chapter instructions and descriptions.
- *A glossary*, located after the appendixes, provides definitions of all word processing words and terms.

Additional information may be obtained from the following DIGITAL documents:

Document	Part Number
Word Processing Operator Training Manual	JB034-A
Word Processing System List Processing User's Manual	AA - 5269B - TK
WPS-8/RCP Communications Options User's Guide	DEC-08-BWCOA-A-D
Letter Quality Printer User's Manual	EK-LQP78-UG-001
LA180 DECprinter I Maintenance Manual	EK-LA180-MM-001

CHAPTER 1 INTRODUCTION

All members of the DIGITAL family of word processing systems contain the same features, provide you with the same capabilities, and operate in the same way. Material typed on one DIGITAL word processing system can be edited or printed on any other.

Here is a summary of features of the DIGITAL family of word processing systems:

- **You can always see your typing on the display screen in front of you.** When you spot a typo, you can correct it and the system will immediately display the results on the screen for your inspection.



M.0805

Figure 1-1 Display Screen

- **You don't have to press the RETURN key when typing "straight" text.** The word processing system will determine where to end each line for you. This action is referred to as "word wrapping" because the system automatically puts a word at the beginning of the next line ("wraps" it down from the previous line).
- **Your typing will be saved automatically.** All you need to do is give your typing a document name. The system will decide where to store it, will keep track of all your other documents in storage, and will record the date and time each is used. Whenever you want to look at or edit some typing, just tell the system the document name and the beginning of it will automatically be displayed on the screen.
- **You can print one document while you type or edit another.** You'll print a document only when you need a copy, not every time

you use it. What's more, you can submit as many as eight documents for printing at one time, and the system will automatically print each in its turn. If you wish, you can have the system determine where to end each page, automatically number the pages, and add extra space between lines for rough drafts.

- **You can change, add, or delete portions of what you've typed without retyping the unchanged material.** The system will automatically expand or condense the spacing to accommodate your changes and will display the results on the screen.
- **You can change the margins or tabs to reformat your typing.** You don't have to retype a single word. The system will automatically readjust the typing to fit the new dimensions selected. You can preview on the screen how your typing looks with the new margins and tabs before printing.

1.1 WORD PROCESSING EQUIPMENT

The word processing **keyboard** lets you type text and tell the system what to do. The word processing **screen** lets you see your typed text plus various messages that help you use the system more efficiently. The word processing **storage** saves your work so you can use it again. The word processing **printer** produces paper copies of your typing. The **PDP-8 minicomputer** is the "brain" that makes the word processing systems work.

This Reference Manual describes how to use four configurations, or members, of the

DIGITAL family of word processing systems. They are the WS78, WS100, WS102, and WS202 (WS stands for Word Station).

The WS78 is a single-user word processing system and includes the following equipment:

- Main keyboard and mini keyboard,
- Display screen,
- One or two dual-diskette drives,
- Large scale integrated (LSI) PDP-8 minicomputer,
- Optional letter quality and/or draft printer.

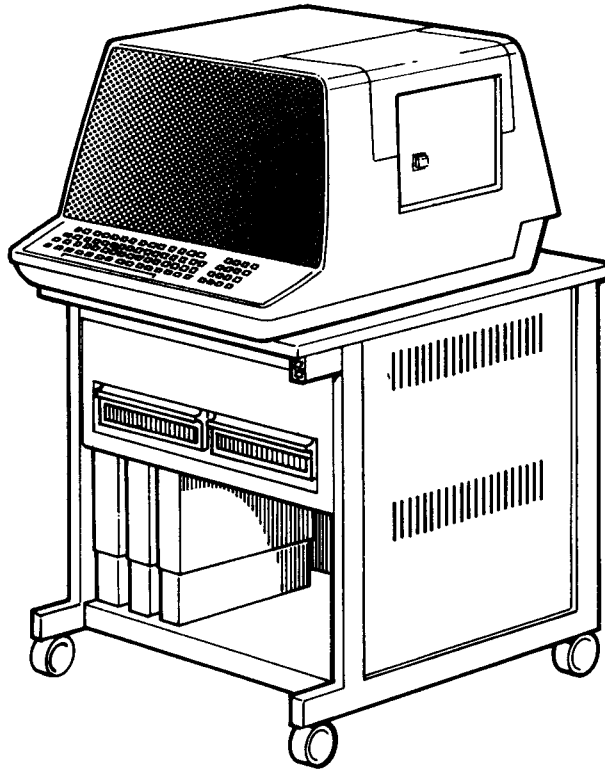

MK-0129

Figure 1-2 WS78

The WS100 is a single-user word processing system and includes the following equipment:

- Main keyboard and mini keyboard,
- Display screen,
- One or two dual-diskette drives,
- PDP-8A minicomputer,
- Optional letter quality and/or draft printer.

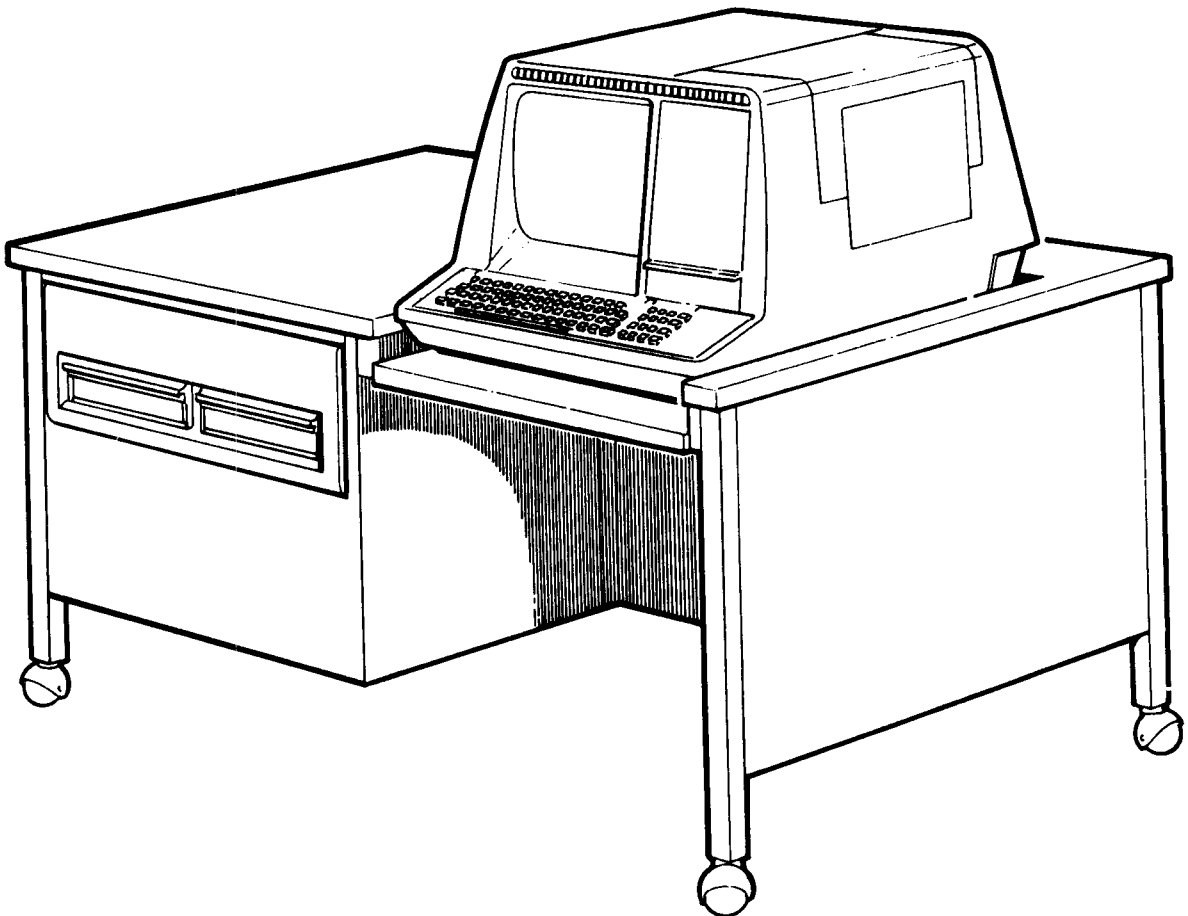

MK-0067

Figure 1-3 WS100

The WS102 and WS202 are two-user word processing systems and include the following equipment:

- Two main keyboards and mini keyboards,
- Two display screens,
- Two dual-diskette drives,

- PDP-8A minicomputer,
- Optional letter quality and/or draft printer.

See Figures 1-4a for the WS102 and 1-4b for the WS202.

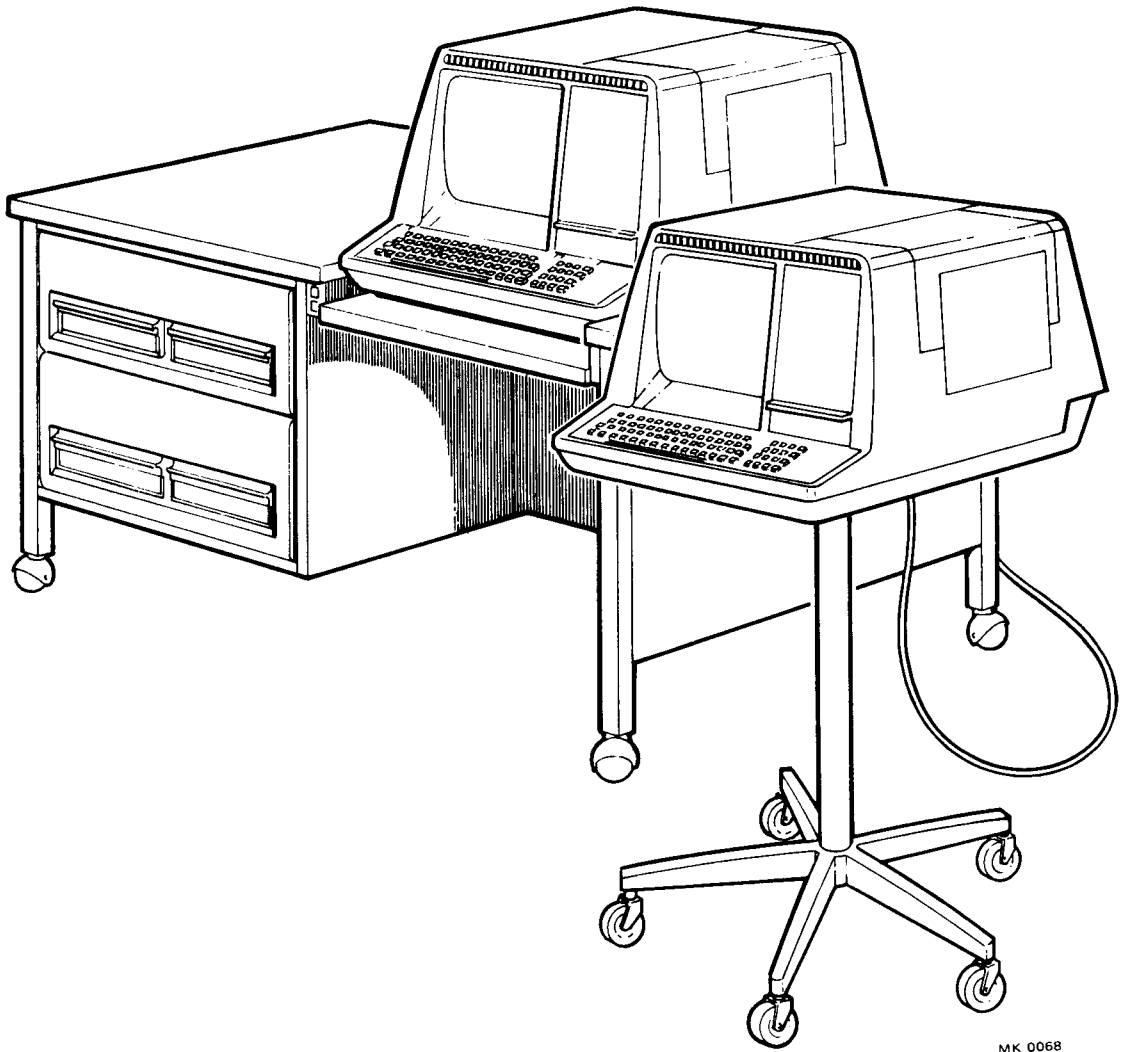

MK 0068

Figure 1-4a WS102

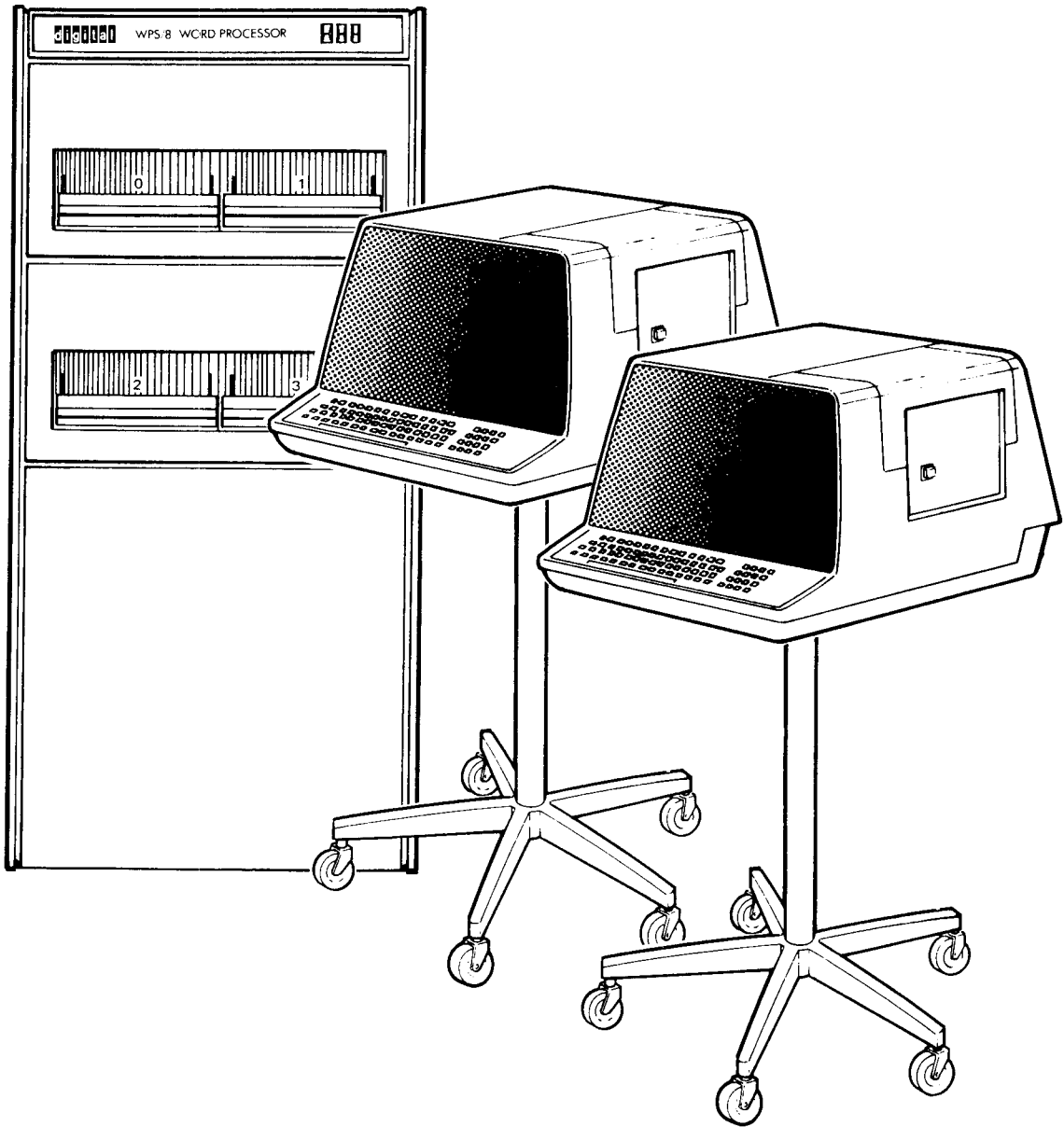

MK-0188

Figure 1-4b WS202

1.1.1 The Keyboard

The word processing system contains two keyboards: a main keyboard and a mini keyboard.

The main keyboard has a standard typewriter keyboard plus some special keys. The special

keys let you correct errors noticed while typing. For example, if you type "tha" instead of "the" you can erase the letter "a" just by pressing the RUB CHAR OUT key. If you type "rhe" instead of "the" you can erase the entire word just by pressing the RUB WORD OUT key.

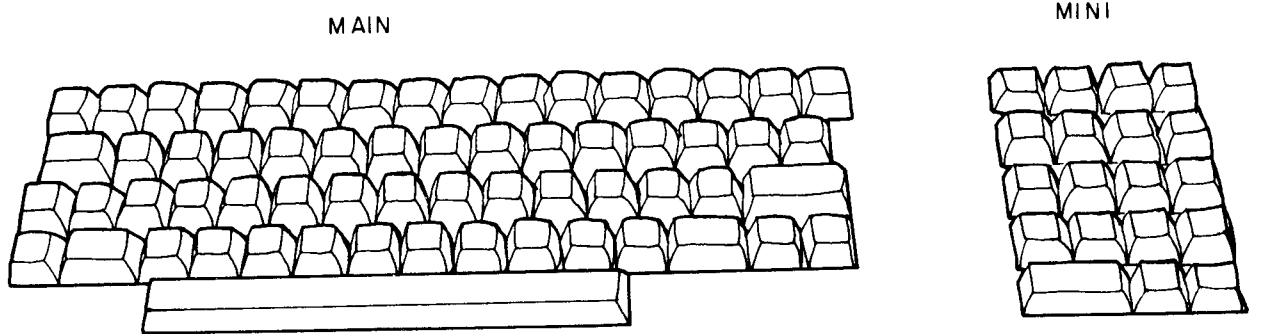

CP - 3249

Figure 1-5 Keyboards

Some main keyboard keys have gold lettering on their front face. When the gold key on the mini keyboard is pressed first, these keys perform the special operation indicated by the gold labels rather than their normal operation. For ex-

ample, you can automatically center a line just by pressing the gold and the CENTR keys (gold lettering on the front face of the "C" key). Appendix A.1 describes all main keyboard keys.

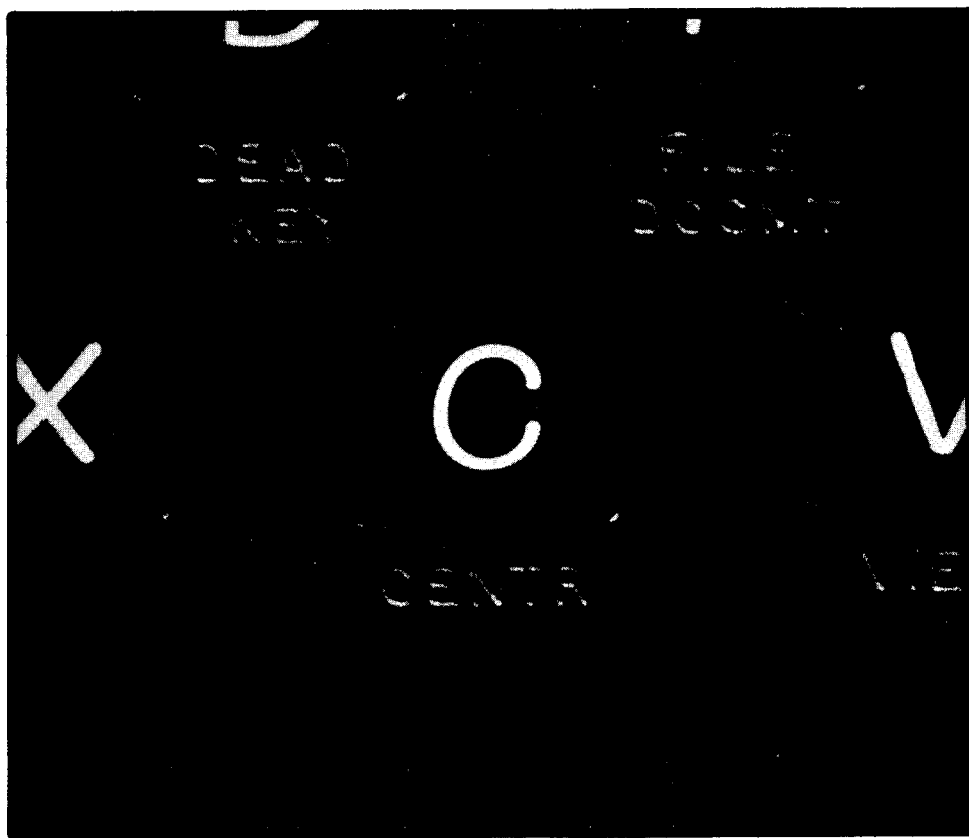

8018-215-A0060

Figure 1-6 Example of Main Keyboard

The mini keyboard, a set of 19 keys to the right of the main keyboard, is used for editing and organizing text. If you want to underline a sentence, for example, press the mini keyboard white UNDER LINE key to tell the system the

action to be performed. Then press the mini keyboard blue SENT (for SENTence) key to tell the system how much typing is to be underlined. Appendix A.2 describes all mini keyboard keys.

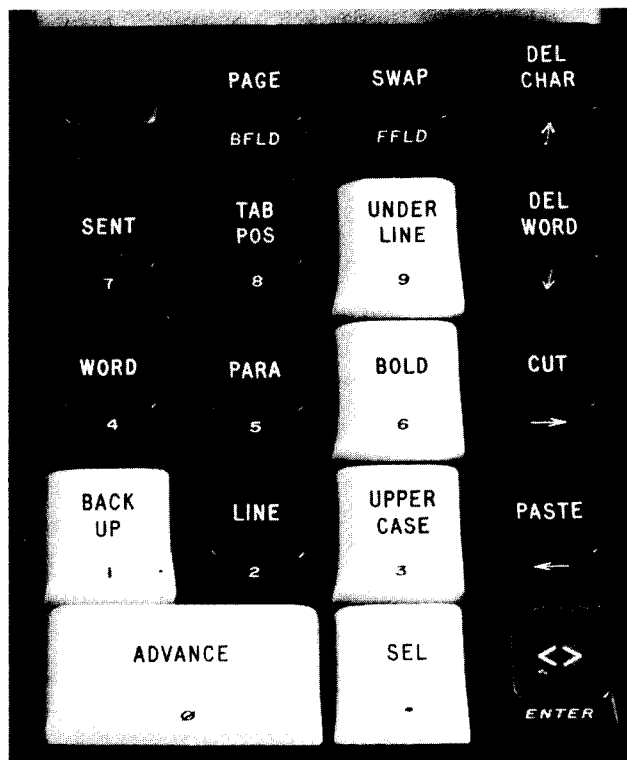

8018-214-A0145

Figure 1-7 Mini Keyboard

1.1.2 The Display Screen

The word processing screen displays 24 80-character lines of text (single-spaced). This display area lets you see what you have just typed and where you are at the present time. When you make changes or type new material, you can see the results instantly on the screen.

All typing and editing is shown on the bottom line of the display screen, just as on a familiar typewriter. The last screen line always contains a blinking underscore character, called a "cursor," that marks your current position and indicates where the next typed character will appear. As you type additional material, the text

moves upward one line, similar to paper being rolled forward in a typewriter.

When working with a lengthy document, you can always find whatever portion you want by moving the text up or down on the screen. This is called scrolling, and is accomplished by mov-

ing the cursor through the document by using the mini keyboard keys.

1.1.3 Storage

The word processing system stores your documents on diskettes. A diskette is about the size and shape of a 45-rpm phonograph record.

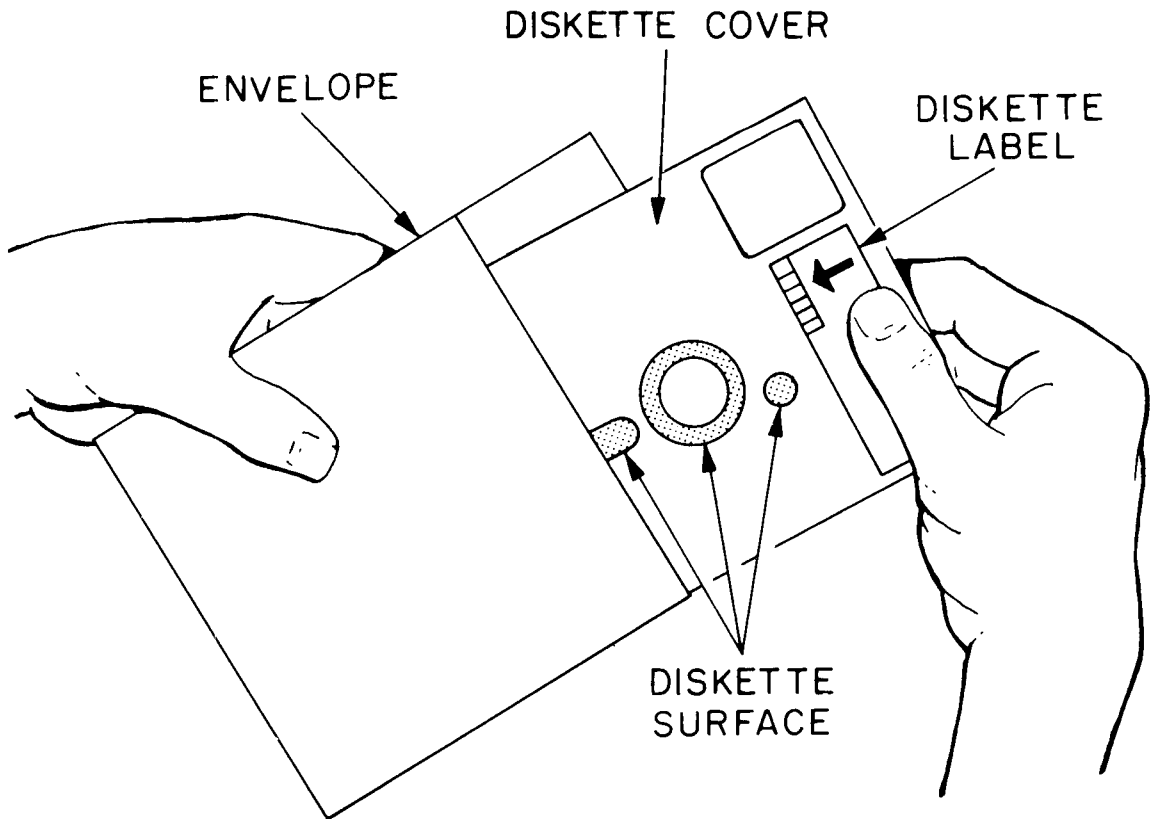

CP-3234

Figure 1-8 Diskette

Diskettes fit in the disk drives, which are similar to phonographs. The right drive holds the document diskette, which stores approximately 125 pages of typing. The left drive holds the system diskette, which contains the programs that run the system plus space for library text (such as form letters, or dictionaries of difficult words), and additional documents.

Document diskettes are completely interchangeable among all DIGITAL word processing systems. On word processing systems with four diskette drives, you potentially have two additional diskettes, or 250 more pages, for document storage. Document storage space is assigned according to the actual size of a docu-

ment. A two-line memo, for example, takes up a fraction of the space of a full page letter, so there is no wasted storage space.

The system automatically maintains an index of each diskette, showing the documents' names, sizes, and the dates each document was originally created and last edited. For example, you don't have to remember whether a document was called "Memo 8/26" or "Relocation Memorandum," because you can look at the index on your screen whenever you desire. In addition, you can print this index to keep a running log of typing activity, or attach it to the diskette jacket or put it in a notebook for quick reference.

```

— DOCUMENT INDEX —
1/24/78 Tue 9:11:51
Drive: 3, Name: HELLO , # of Docs: 5, Blocks left: 439 (of 627)

```

Document Number	Name	Created	Modified	Size	Version	Elapsed Time Last	Total
* 6	index	1/5/78	1/16/78 9:54	3	2	0:00	0:00
5	Memo for basic information on preliminary plan	11/11/77	11/11/77 16:31	10	1	0:01	0:01
3	abbrv	11/4/77	11/4/77 11:12	1	3	0:01	0:05
2	intro part ii	11/2/77	11/7/77 10:07	168	22	0:06	4:43
1		11/2/77	1/16/78 9:53	1	9	0:00	0:00

Press RETURN to display more entries
OR Gold MENU to recall the Main Menu.

9113-23R1-A0075

Figure 1-9 Document Index

1.1.4 Printers

Two types of printers are available for purchase with all DIGITAL word processing systems: a letter quality printer and a draft printer. The letter quality printer produces typing comparable

to a typewriter at an average speed of 540 words per minute. The draft printer produces typing comparable to a computer printout at an average speed of 2160 words per minute, or approximately four times faster.

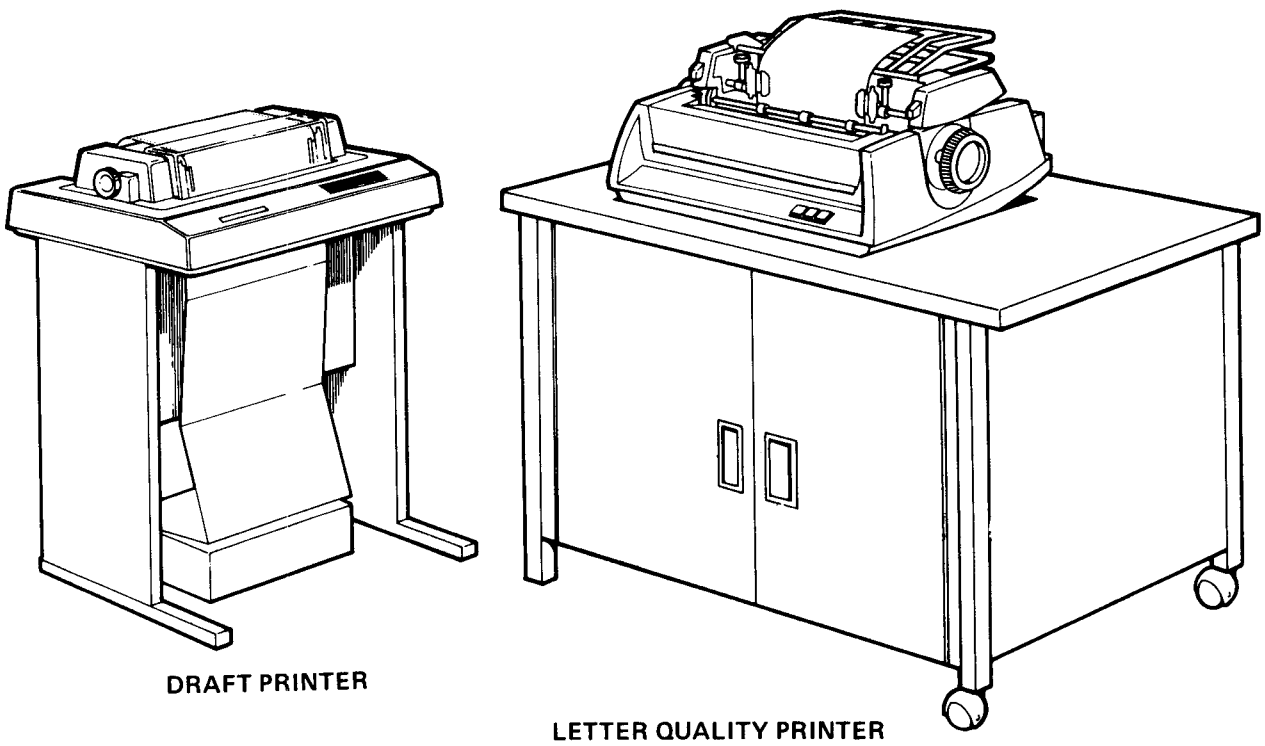

MK-0066

Figure 1-10 Printers

1.2 USING THE WORD PROCESSING SYSTEM

When you use a DIGITAL word processing system, you don't have to memorize special codes or instructions. The system leads the way by displaying menus, prompts, and error messages on the screen. You'll always know what to do next.

A *menu* is a list of options from which you can choose an action to perform. The Main Menu is the heart of the word processing system. It provides such "main" options as document creation, editing, and printing (similar to choosing your main course from a restaurant menu). Appendix B summarizes all Main Menu options and provides a cross-reference to where each is described in this Reference Manual.

```
-- MAIN MENU --                                1/24/78 Tue 9:06:00

C = Create a new letter or document
E = Edit an existing letter or document
P = Print a letter or document
I = Index of letters and documents on file
F = Finished using the system
M = More main menu selections...

Type the letter and then press RETURN.
```

9113-3R1-A0062

(Version 2.7)

```
-- MAIN MENU --                                4/6/78 Thu 10:37:37

C = Create a new letter or document
E = Edit an existing letter or document
P = Print a letter or document
I = Index of letters and documents on file
D = Delete a document
F = Finished using the system
M = More main menu selections...

Type the letter and then press RETURN.
```

M113-12A0385

(Version 3.0)

Figure 1-11 Main Menu

Depending on the Main Menu option selected, the system may display other menus from which you can choose suboptions (similar to deciding among "rare," "medium," and "well-done" after you've selected steak as your main course).

For example, if you select the Main Menu printing option, the system will display a Print Menu letting you choose how many copies to print or what size paper to use, to list just a few of the printing suboptions.

```
-- PRINT MENU --                               9/30/77 Fri 12:34:32

These are the current settings for printing document:

(1.28) s11 hyphenation

1 copy will be printed                          66 total lines per page
1 is the number on the first page               6 lines in the top margin
1 is the first page printed                     6 lines in the bottom margin
                                                10 characters per inch (pitch)

0 extra half-line space between lines
0 spaces added to the left margin
0 spaces between columns
do not stop before every page
automatically break into pages
do not print extra dark
do not print with two wheels
document destination is LQP

If all settings are correct type YES, otherwise type NO,
then press RETURN.
```

8920-14R3-A0061

Figure 1-12 Print Menu (Version 2.7)

```

-- PRINT MENU --
4/6/78 Thu 10:57:42
These are the current settings for printing document:

(0.2) index
10 characters per inch (pitch)      66 total lines per page
1 copy will be printed              6 lines in the top margin
1 is the number on the first page   6 lines in the bottom margin
1 is the first page printed         0 spaces added to the left margin
                                     0 spaces between columns

0 extra half-line space between lines
do not stop before every page
automatically break into pages
do not print extra dark
do not print with two wheels
document destination is LQP

If all settings are correct type YES, otherwise type NO,
then press RETURN.

```

M113-2BWA0382

Figure 1-12 Print Menu (Version 3.0)

A *prompt* is a request for additional information. The system displays prompts as the need arises. For example, if you tell the system you want to print a document, it will display the following prompt on the screen:

```

1/24/78 Tue 9:00:28

Type the name of the document you want to print and press RETURN
OR Just press RETURN if the document desired is (1.17) index
OR Press Gold MENU to recall the Main Menu.

```

9113-15R1-A0064

Figure 1-13 Example of Prompt

When responding to a prompt, always be certain to follow the spacing shown on the screen and to distinguish between the letter "l" and the numeral "1." These two characters are NOT interchangeable.

An *error message* is displayed on the screen whenever you make an inappropriate response to a menu or prompt. (See below.)

Whenever you try to do something that's not possible, the system will buzz to alert you. For example, if you try to move the cursor forward when it is located on the very last character of your document, the system will buzz.

If you're a fast typist, you can type instructions faster than the word processing system can re-

spond. The system will "stack" them for you and act on each only when the previous one has been completely processed. For example, if you know you want to add new material to the top of the second page of a document, you can type the letter E and the document's name (to tell the system you want to Edit a particular document), and start typing your new material even before the system has displayed the bottom of the document on the screen.

When typing text, you should press the RETURN key only at the end of a paragraph, list item, or table entry. Do NOT press the RETURN key when typing straight text (because the word processing system automatically "word wraps" your typing, or determines where to end each line).

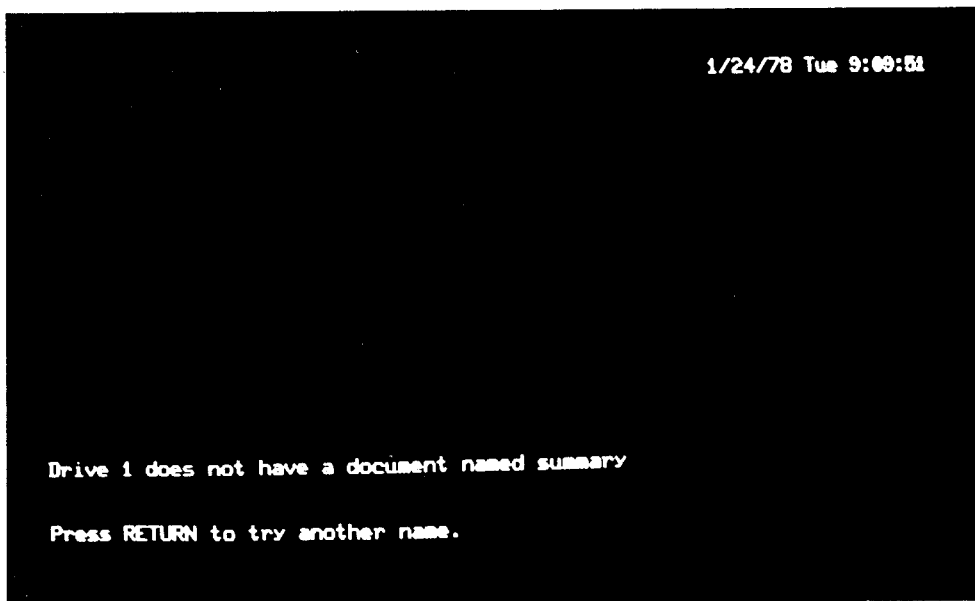

9113-17R1-A0063

Figure 1-14 Example of Error Message

CHAPTER 2 OPERATING THE WS78 EQUIPMENT

The WS78 word processing system consists of hardware and software. *Hardware* is the actual equipment you can see – the keyboards, the display screen, the diskette drives and the computer. *Software* is computer programs that allow you to operate the equipment in a particular way. The word processing software allows you to type text, correct errors, save the text for using again, and print what you've typed.

To start up the WS78 word processing system, you must make both the hardware and the software operational. Start up requires two diskettes: (1) a system diskette, which contains the WS78 software, and (2) a document diskette, which contains (or will contain) the documents you create and edit. If you don't already have these diskettes, see your System Manager.

In summary, to start up the WS78 hardware and software, follow these steps:

1. Press the ON/OFF switches to supply electrical power to the hardware (see Section 2.1).

2. Insert the system and document diskettes (see Section 2.2).
3. Press the START switch to bootstrap, or activate, the software (see Section 2.3).
4. Type today's date and the time, and press the RETURN key (see Section 2.4).

Once you start up the hardware and software, the Main Menu is displayed on the screen. This menu gives you a selection of word processing work you may perform. See Section 2.5 for how to use the Main Menu.

2.1 TURNING ON THE MACHINE

If you see some words or a blinking underscore character on the screen, the machine is on already. All you then have to do is insert the diskettes, bootstrap, and type the date and time (see Sections 2.2 - 2.4). You can do this provided no one has left the terminal unattended (with work in process). It is available if the screen displays either the message "FINISHED USING THE SYSTEM" or some instructions that begin with "MAIN MENU."

To turn on the machine, follow these steps:

1. Make sure the ON/OFF switch (located on the back of the terminal) which supplies power to the display screen is in the ON position (up).

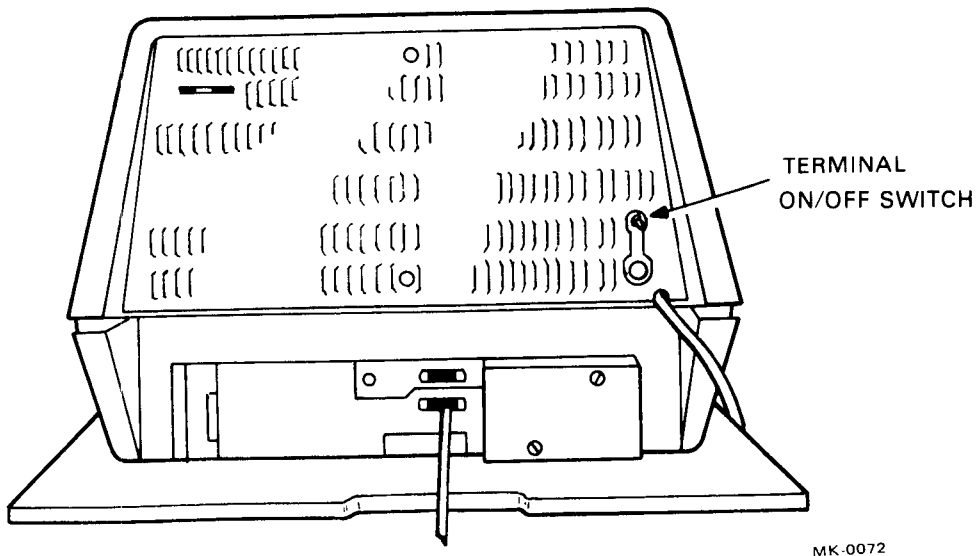
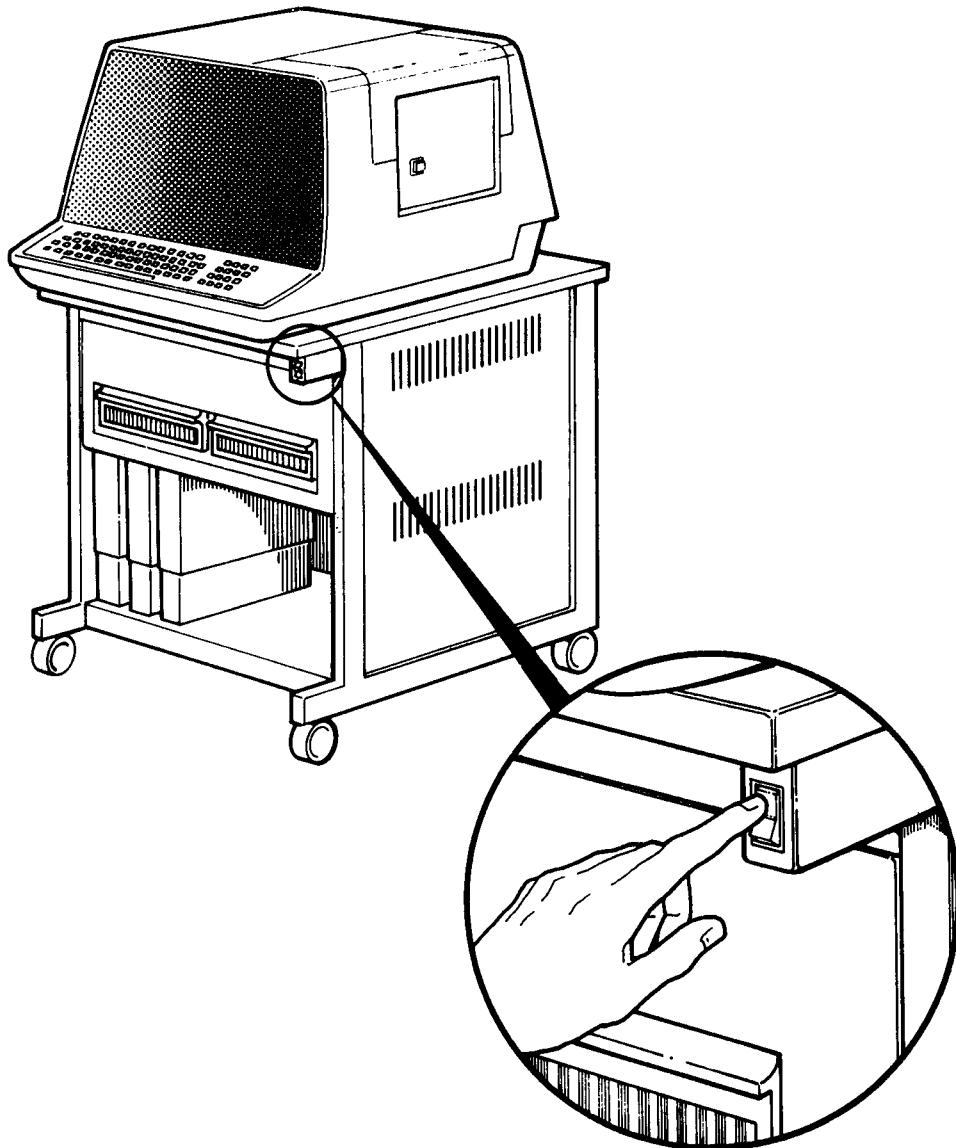

Figure 2-1 WS78 Display Screen
ON/OFF Switch

2. Push up the ON/OFF switch which supplies power to the entire system (located on the stand under the right front of the terminal). The word processing system will start to hum. If nothing happens, check that the

power plug is securely in the wall socket. (If it is, and your system still does not respond, call your DIGITAL Field Service Representative.)



MK 0128

Figure 2-2 WS78 Terminal ON/OFF Switch

After the system warms up, the characters
ABCDEF
plus a line of dashes and the cursor (a blinking
underscore character) will appear on the screen.

Insert your diskettes BEFORE proceeding further.

2.2 INSERTING THE DISKETTES

A diskette is a round piece of magnetic material, about the size of a 45-rpm record, kept inside a nonremovable square protective cover. The diskette and protective cover fit into a special envelope when not in use.

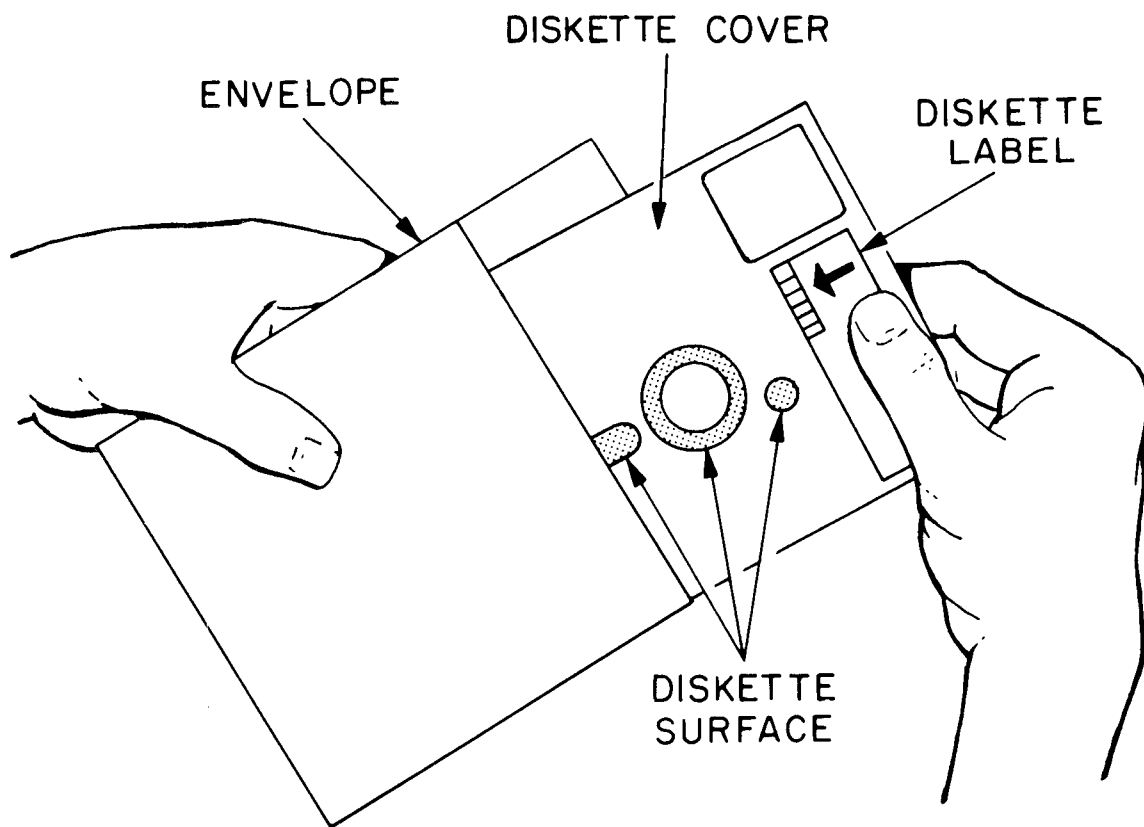

CP-3234

Figure 2-3 Diskette

To operate the WS78 word processing system, insert your system diskette and your document diskette by following these steps:

1. Open the diskette drives by squeezing the handles with your thumb and forefinger. If

either already contains a diskette (left there by the previous user), remove it.

2. Remove the system diskette from its envelope and insert it in the left diskette drive (drive zero). Push down on the handle until it snaps shut.

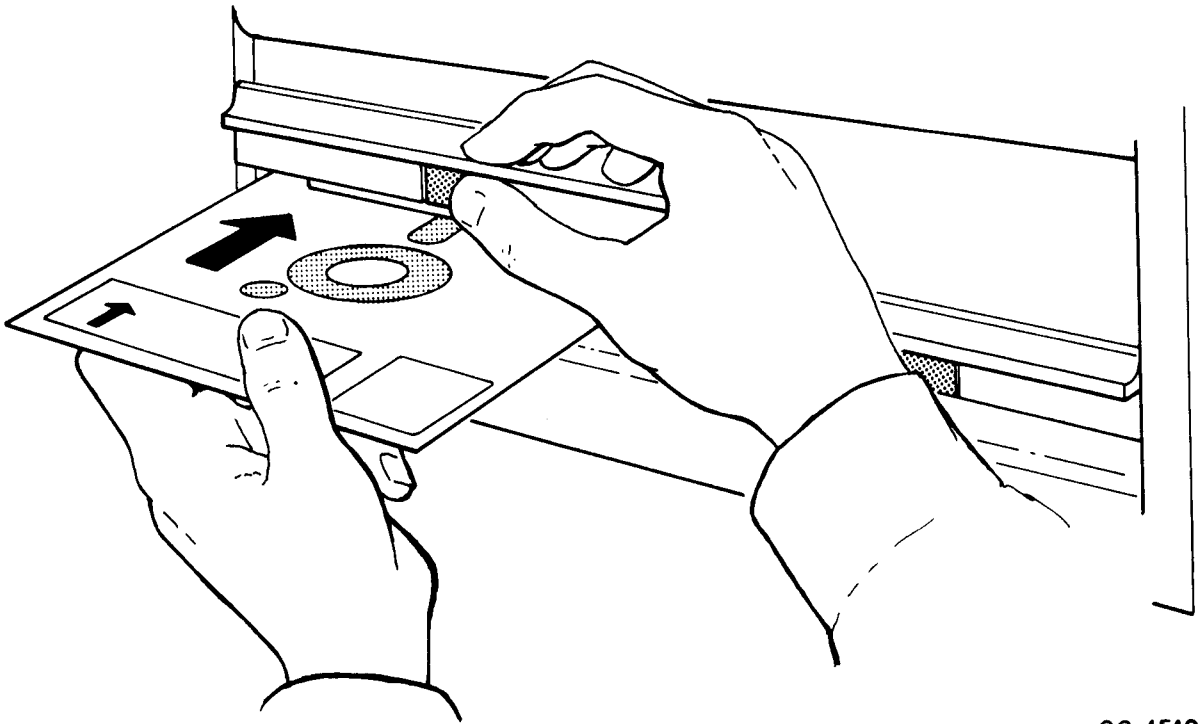

08-1519

Figure 2-4 Inserting System Diskette in Drive

3. Insert your document diskette in the right drive (drive one) the same way you inserted the system diskette.

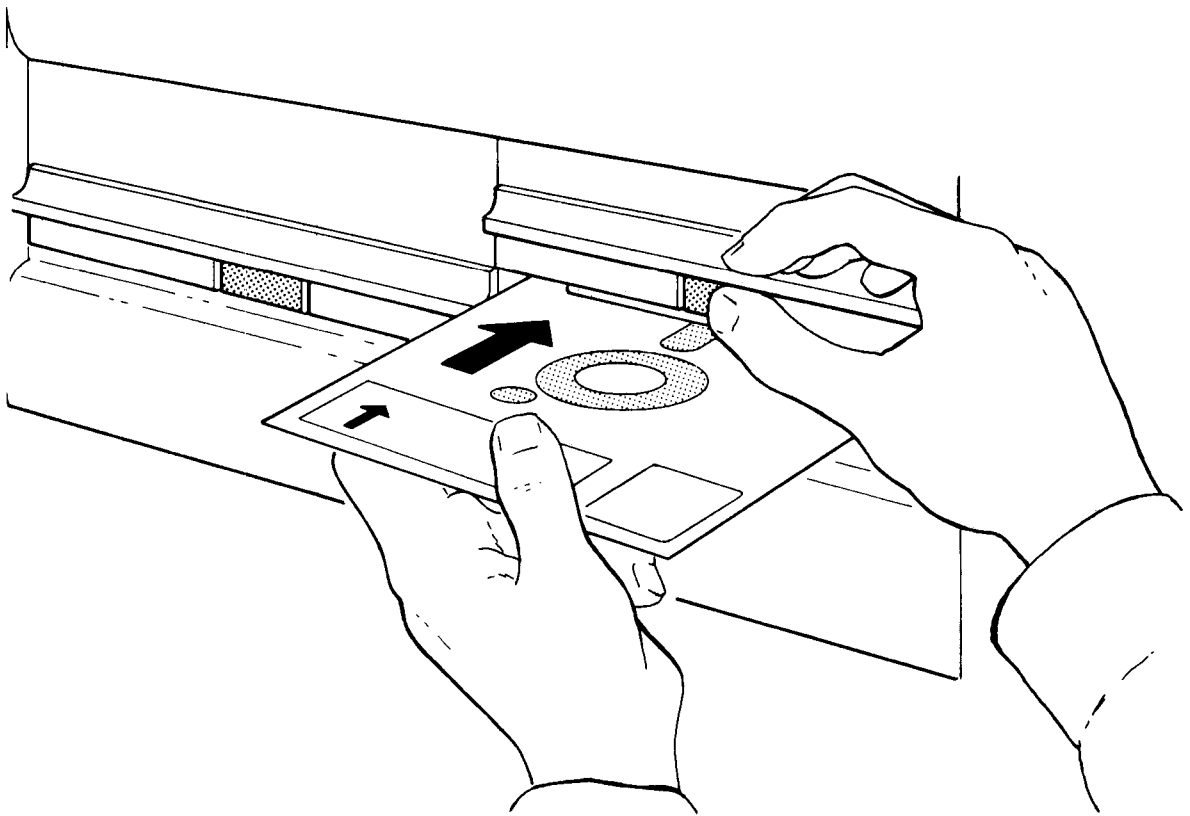

08-1530

Figure 2-5 Inserting Document Diskette
in Drive

2.3 BOOTSTRAPPING

The first step in starting up the software is called *bootstrapping*. This term is derived from the adage "Pull yourself up by your bootstraps." Technically speaking, bootstrapping means to put a

small program into the computer memory which, in turn, inserts a larger program.

To bootstrap, press the blue START switch located on the right side of the terminal.

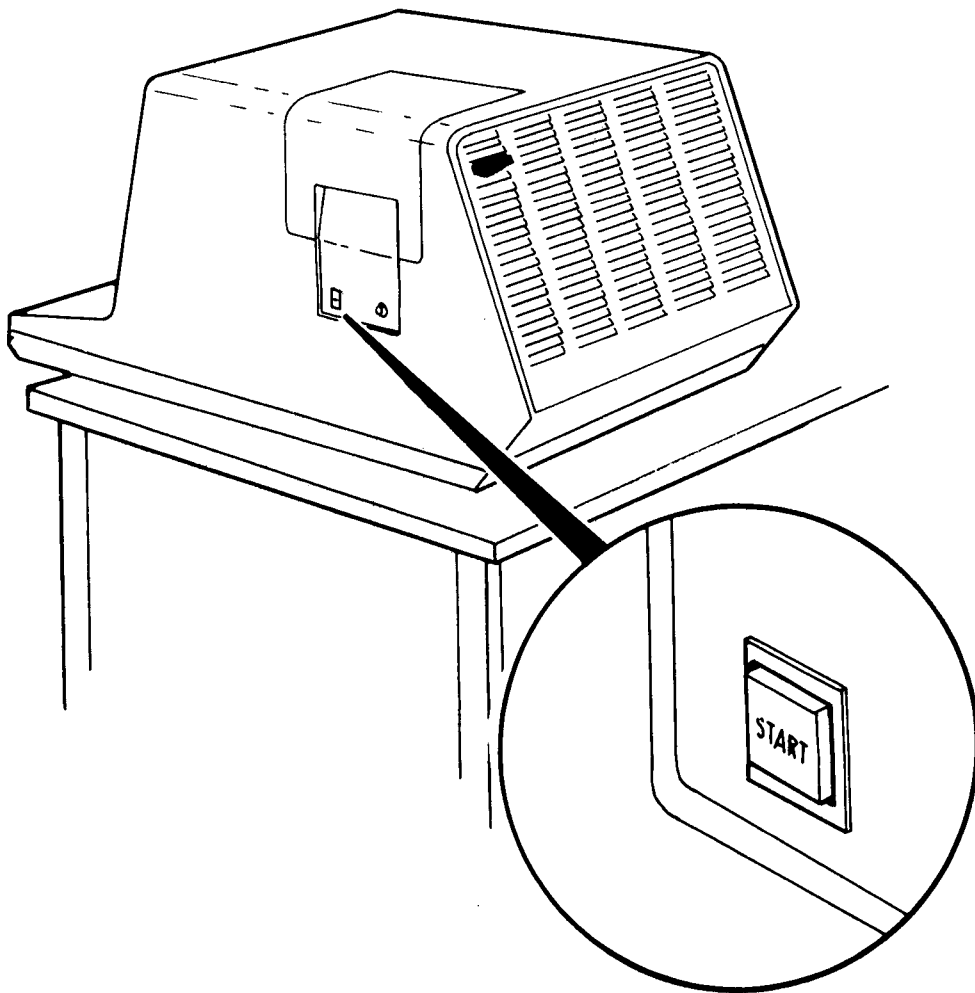

CP-3233

Figure 2-6 WS78 START Switch

A message that looks like the following will be displayed on the screen:

```
START 1000 1132; AC,MQ 4120 0000ABC
```

Do not be concerned that the numbers actually displayed on your screen differ from those above. These numbers are only an example.

The characters "ABC" will briefly be displayed on the screen and will be followed by the word processing Date/Time Menu.

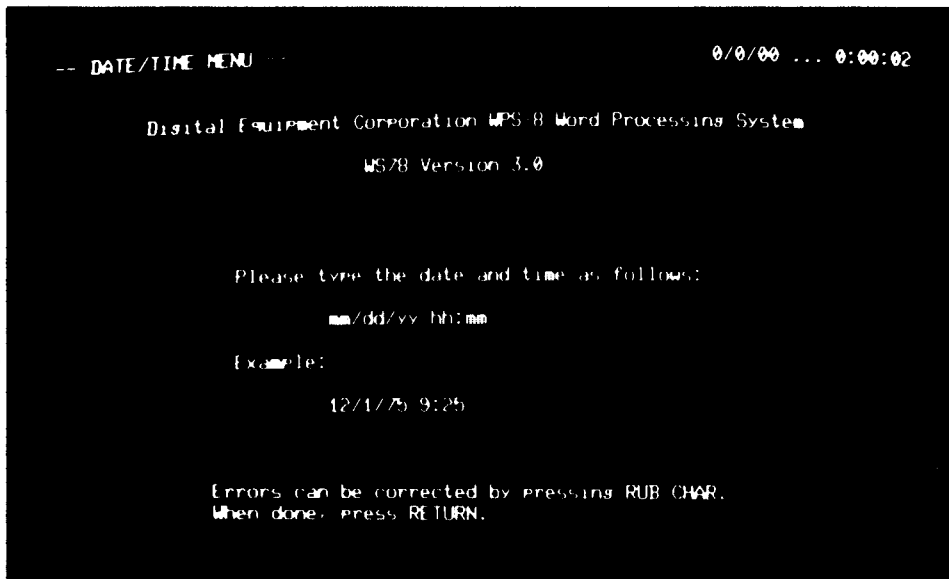

M113-7A0391

Figure 2-7 WS78 Date/Time Menu

Before going further, look at the white/black contrast on your screen. If it is too bright or too blurry, you can adjust it with the INTENSITY CONTROL switch (located on the back of the terminal).

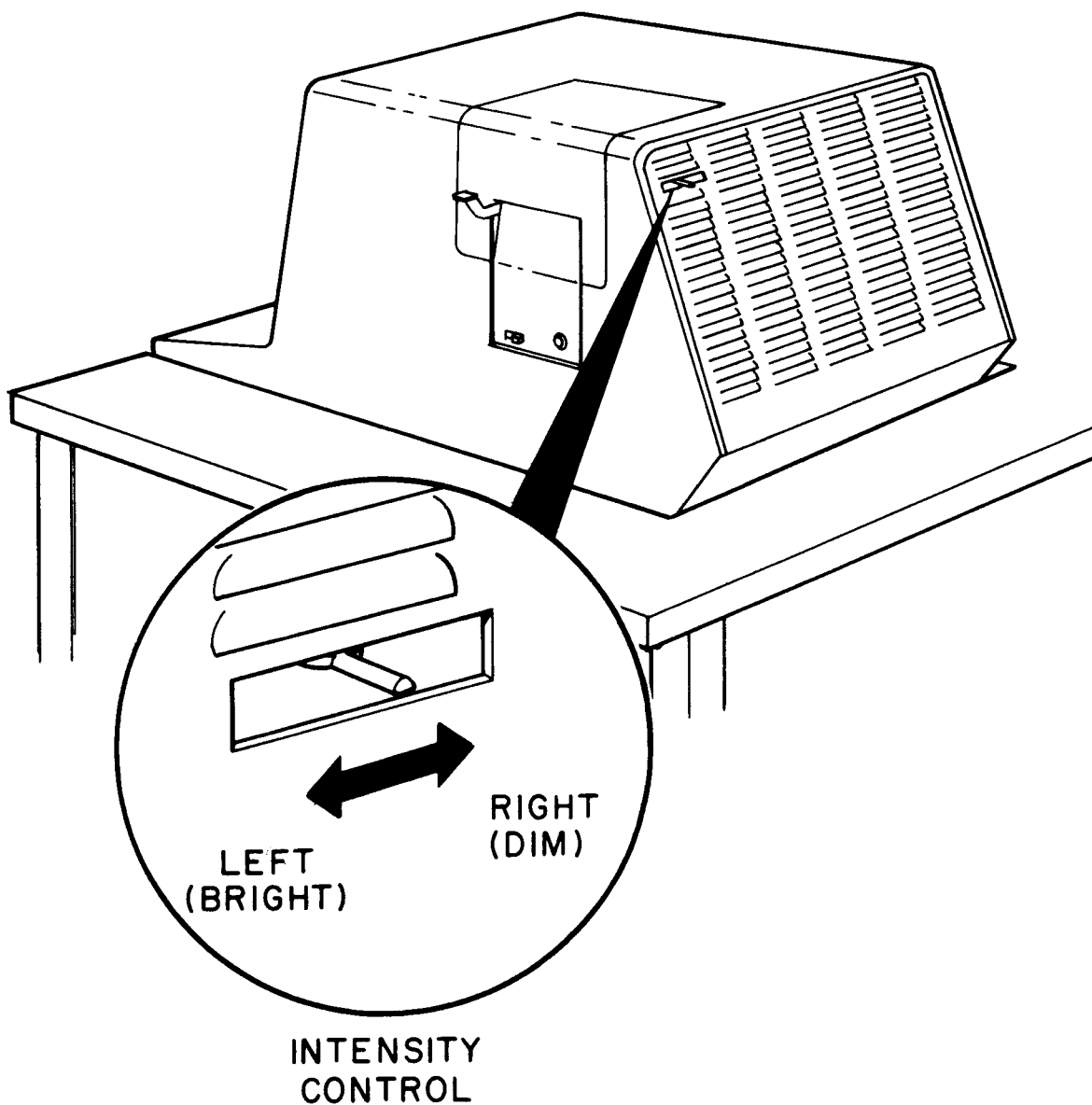

08-1560

Figure 2-8 WS78 Intensity Control Switch

2.4 TYPING THE DATE AND TIME

Respond to the prompt by typing today's date and the present time and then press the RETURN key. Be sure to follow the format and spacing as the Date/Time Menu instructs and to use the number 1 instead of the letter l. It is preferable to use a 24 hour clock (for example, type 5 p.m. as 17:00).

If you make a mistake before pressing the RETURN key, press the RUB CHAR OUT key (second row, upper right of the main keyboard). Pressing RUB CHAR OUT causes a back space and erases the character to the left of the cursor. To remove the entire date or time, press the RUB WORD OUT key (located just left of the RUB CHAR OUT key). This causes a back space and erases the word to the left of the cursor.

If you don't specify the date and time correctly, the following message is displayed on the screen:

Date/Time typed incorrectly. Try again.

Retype the date and time and press the RETURN key.

You may omit typing the date or time and just press the RETURN key. No harm will be done, but your bookkeeping will not be entirely accurate. The word processing system keeps an index in which it records when you use each document (among other information). Therefore, if you don't specify a date, the word processing system cannot record the correct bookkeeping information.

2.5 MAIN MENU

After you type the date and time, the first page of the Main Menu is displayed on the screen. Notice that the date and time are displayed in the upper right corner. The day of the week (abbreviated to three letters) and the time in seconds are also displayed there. If you should be working at midnight, the screen display will automatically change to reflect the new date and time (provided you specified the time in 24 hour clock format).

```
— MAIN MENU —                               1/24/78 Tue 9:06:00

C = Create a new letter or document
E = Edit an existing letter or document
P = Print a letter or document
I = Index of letters and documents on file
F = Finished using the system
M = More main menu selections...

Type the letter and then press RETURN.
```

9113-3R1-A0069

(Version 2.7)

```
— MAIN MENU —                               4/6/78 Thu 10:37:37

C = Create a new letter or document
E = Edit an existing letter or document
P = Print a letter or document
I = Index of letters and documents on file
D = Delete a document
F = Finished using the system
M = More main menu selections...

Type the letter and then press RETURN.
```

M113-12-A0183

(Version 3.0)

Figure 2-9 Main Menu Page One

The Main Menu lists the special options of the word processing system. To perform any option, type its letter(s) and press the RETURN key.

Because the system provides so many different options, there are several pages to the Main Menu. To display each successive page, type the letter M and press the RETURN key. If you type M and press the RETURN key when the last Main Menu page is on the screen, the first page will be displayed again. For a complete listing of all Main Menu options, refer to Appendix B.

You can type any Main Menu option regardless of what Main Menu page is displayed. For example, if you have completed your word processing work, you can type P (to Print a document) and press the RETURN key even if

the second or third Main Menu page is displayed.

2.6 RESETTING THE DATE AND TIME

The RD Main Menu option allows you to reset the date and time. This is useful if you accidentally type the wrong date or time (if it's January 1977 and you're still in the habit of typing 1976). To reset the date or time, type the letters RD (when any Main Menu page is displayed on the screen) and press the RETURN key. The Date/Time Menu is displayed once again. You can now proceed to type the correct date and time.

2.7 STOPPING

When you are finished using the word processing system, type the letter F (for Finished) and press the RETURN key. The following message is displayed on the screen:

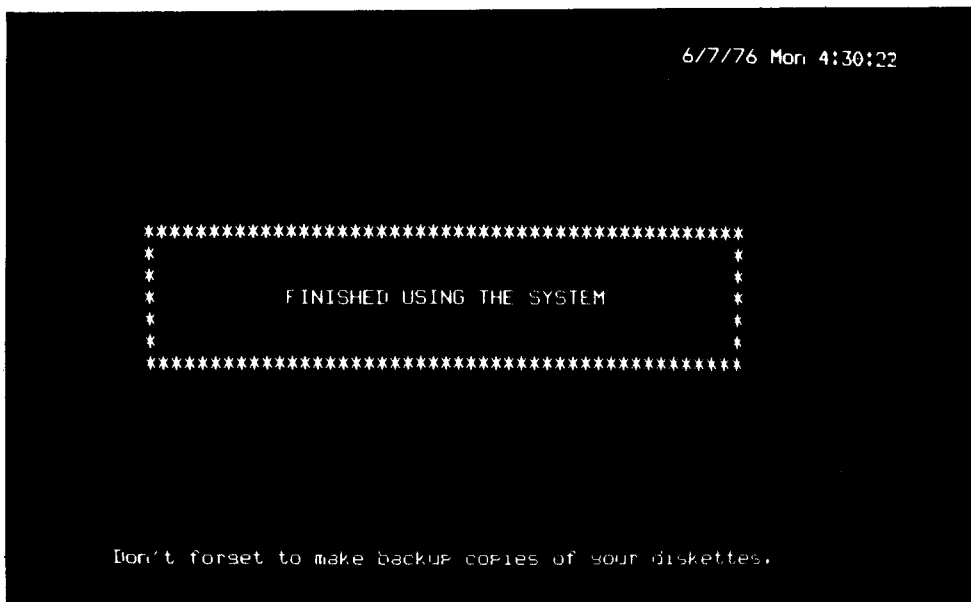

8018-78-A0067

Figure 2-10 Finished Message

If you intend to take a lengthy break and no one else wants to use the word processing system, remove your diskettes and turn off the machine to conserve energy. Just press the red OFF switch located on the front of the machine.

2.8 POWER FAILURES AND BROWN-OUTS

If the power supply to your WS78 system ever fails, you may lose approximately one page of your most recent typing. When power is restored, do the following:

1. Bootstrap the system once again (see Section 2.3).

2. Verify your diskettes to make certain no electrical damage was done (see Section 17.2.3).

If the system ever stops responding to your typing, you have experienced a brown-out, a momentary drop in power supply. You may lose approximately one page of your most recent typing. If the characters "ABCDEF" are displayed on the screen instead of your document, portions of your document may be missing. Should this occur, perform the two steps described above for recovering from a power failure.

CHAPTER 2 OPERATING THE WS100 EQUIPMENT

The WS100 word processing system consists of hardware and software. *Hardware* is the actual equipment you can see – the keyboards, the display screen, the diskette drives, and the computer. *Software* is computer programs that allow you to operate the equipment in a particular way. The word processing software allows you to type text, correct errors, save the text for using again, and print what you've typed.

To start up the WS100 word processing system, you must make both the hardware and the software operational. Start up requires two diskettes: (1) a system diskette, which contains the WS100 software, and (2) a document diskette, which contains (or will contain) the documents you create and edit. If you don't already have these diskettes, see your System Manager.

In summary, to start up the WS100 hardware and software, you follow these steps:

1. Press the ON/OFF switches to supply electrical power to the hardware (see Section 2.1).
2. Press the START switch to bootstrap, or activate, the software (see Section 2.2).

3. Insert the system and document diskettes (see Section 2.3).
4. Press the RETURN key to display the Date/Time Menu. Type today's date and the time, and press the RETURN key (see Section 2.4).

Once you start up the hardware and software, the Main Menu is displayed on the screen. This menu gives you a selection of word processing work you may perform. See Section 2.5 for how to use the Main Menu.

2.1 TURNING ON THE MACHINE

If you see some words or a blinking underscore character on the screen, the machine is on already. All you then have to do is bootstrap, insert the diskettes and type the date and time (see Sections 2.2 - 2.4). You can do this provided no one has left the terminal unattended (with work in process). It is available if the screen displays either the message "FINISHED USING THE SYSTEM" or some instructions that begin with "MAIN MENU."

To turn on the mainline, follow these steps:

1. Make sure the ON/OFF switch (black, located on the side of the terminal) which supplies power to the display screen is in the ON position.

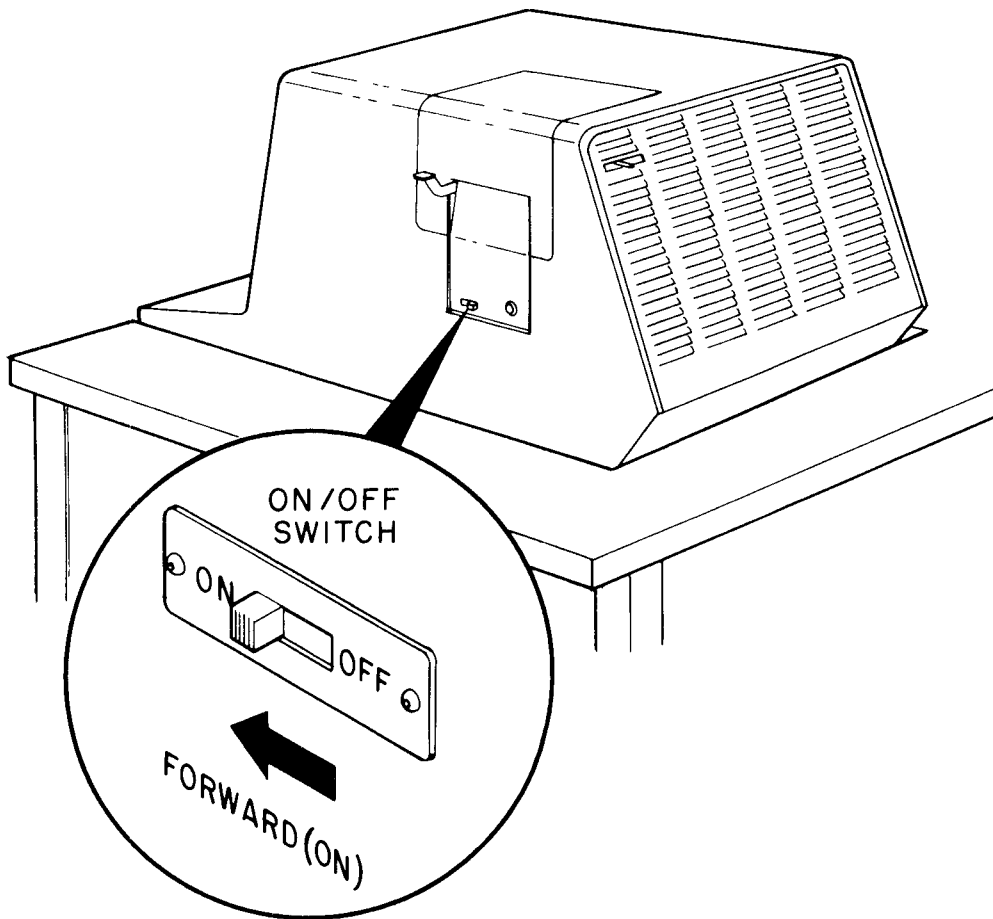

08-1558

Figure 2-1 WS100 Display Screen Switch

2. Push in the ON/OFF switch which supplied power to the entire system (red, located on the front of the system). The word processing system will start to hum. If nothing happens, check that the power plug is securely in the wall socket. (If it is, and your system still does not respond, call

your DIGITAL Field Service Representative.)

After the system warms up, the cursor (a blinking underscore character) will appear in the upper left corner of the screen.

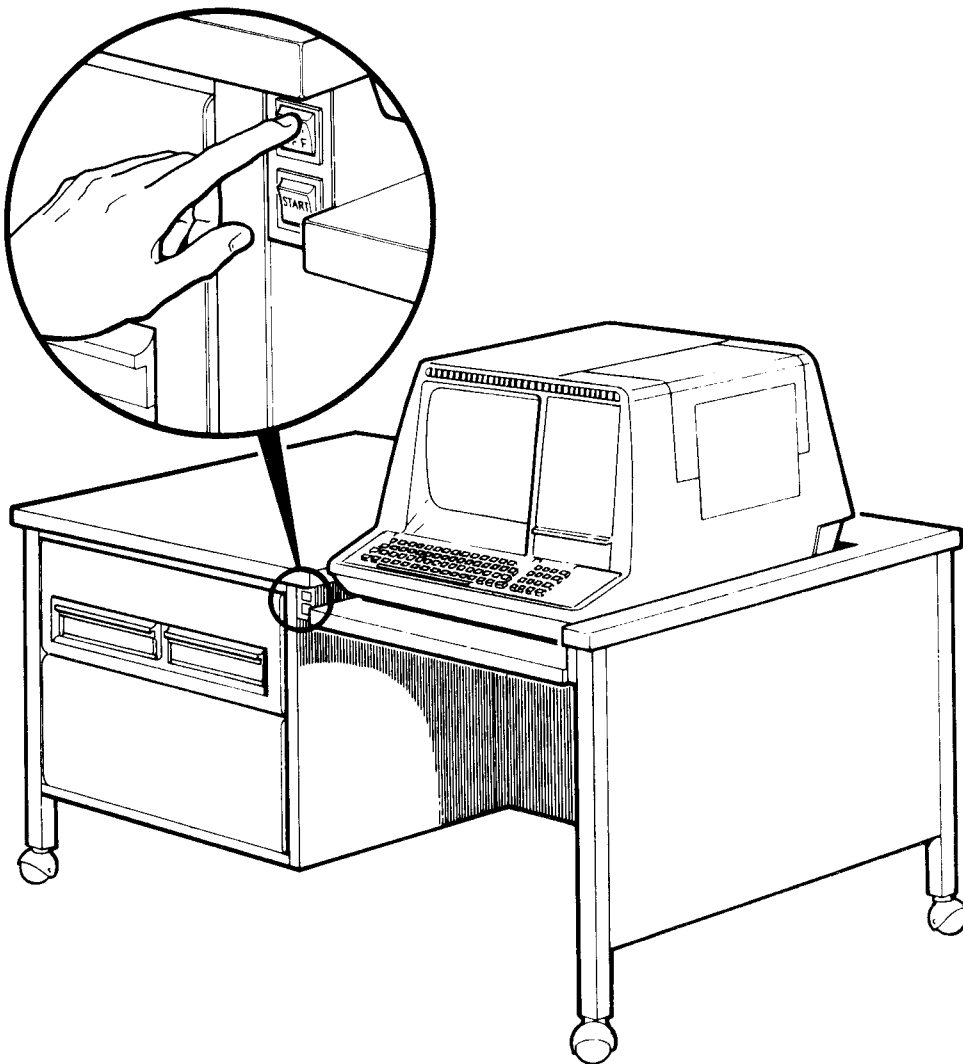

MK 0071

Figure 2-2 WS100 ON/OFF Switch

2.2 BOOTSTRAPPING

The first step in starting up the software is called *bootstrapping*. This term is derived from the adage "Pull yourself up by your bootstraps." Technically speaking, bootstrapping means to put a small program into the computer memory which, in turn, inserts a larger program.

To bootstrap, press the white START switch located on the front of the terminal right beneath the ON/OFF switch. The characters "0123" will be displayed in the upper left of the screen.

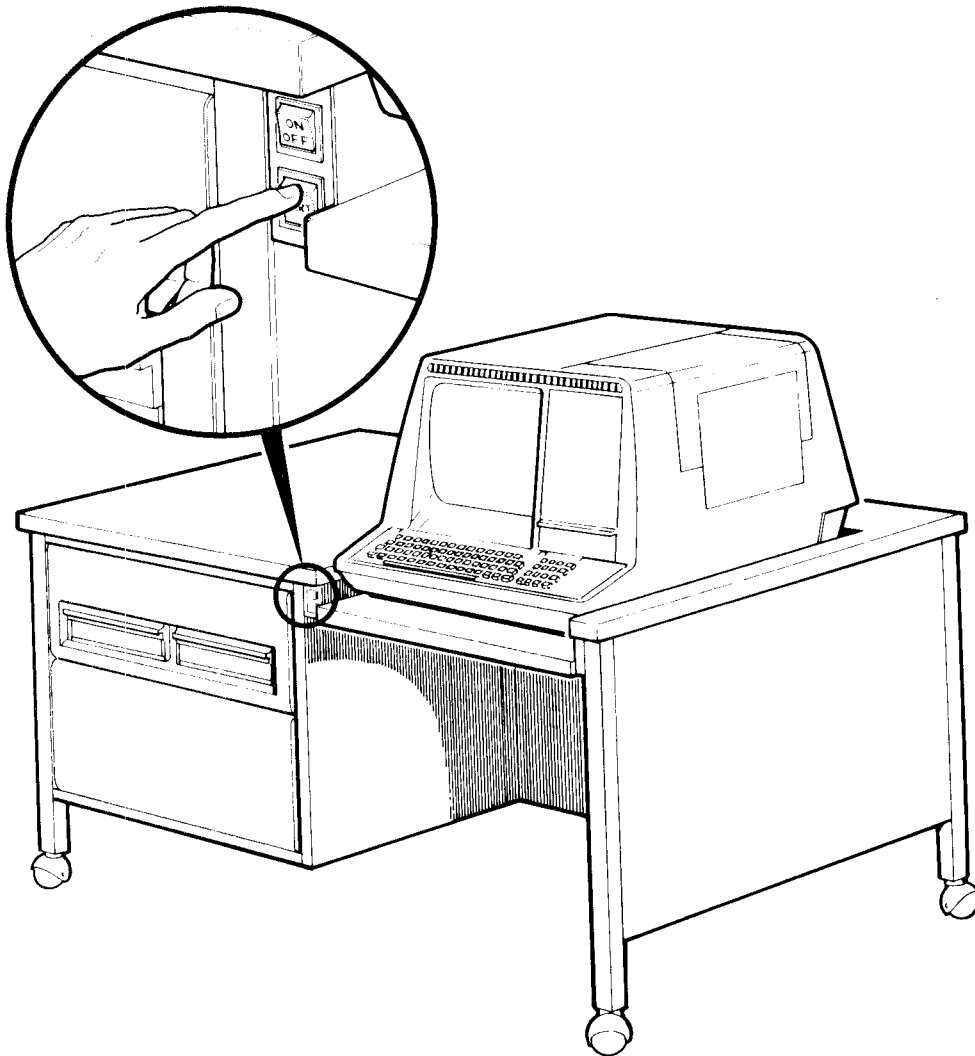

MK 0070

Figure 2-3 WS100 START Switch

2.3 INSERTING THE DISKETTES

A diskette is a round piece of magnetic material about the size of a 45-rpm record, kept inside a nonremovable square protective cover. The diskette and protective cover fit into a special envelope when not in use.

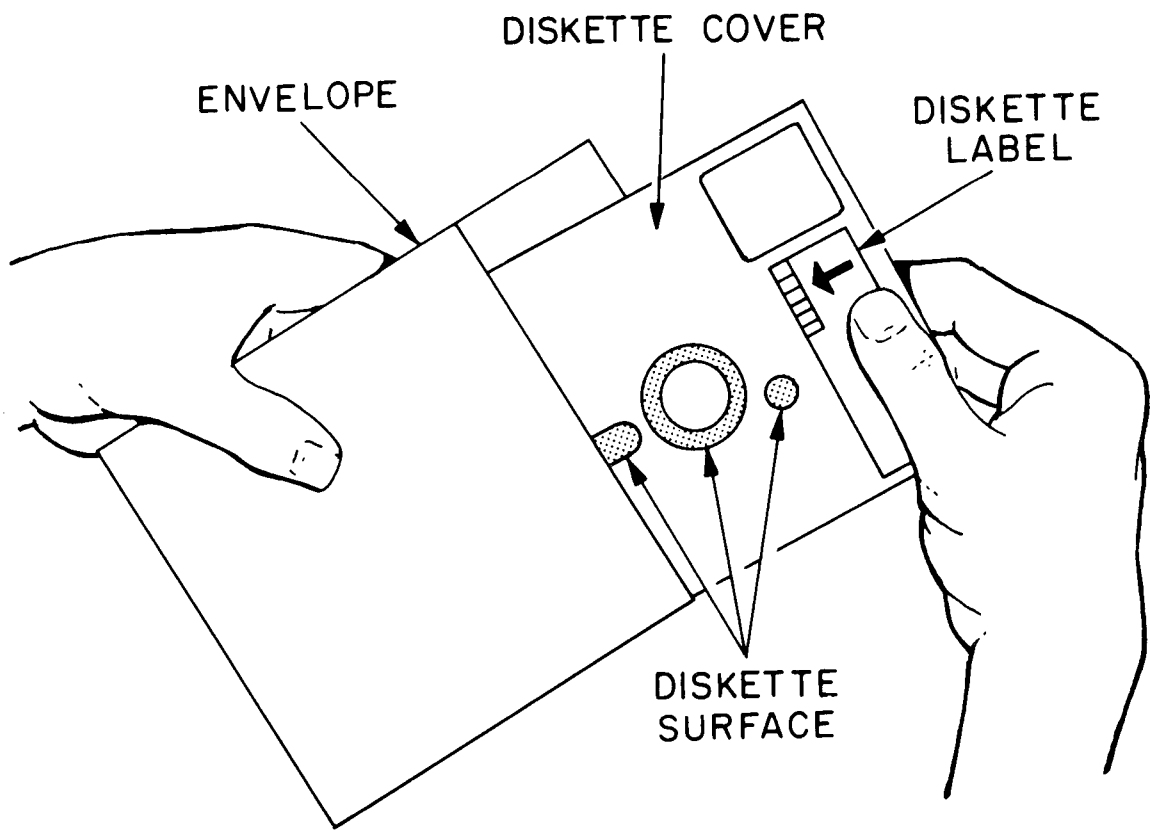

CP-3234

Figure 2-4 Diskette

To operate the WS100 word processing system, insert your system diskette and your document diskette by the following method. If your system has four diskette drives, use the top two.

1. Open the diskette drives by squeezing the handles with your thumb and forefinger. If

either already contains a diskette (left there by the previous user), remove it.

2. Remove the system diskette from its envelope and insert it into the left diskette drive (drive zero). Push down on the handle until it snaps shut.

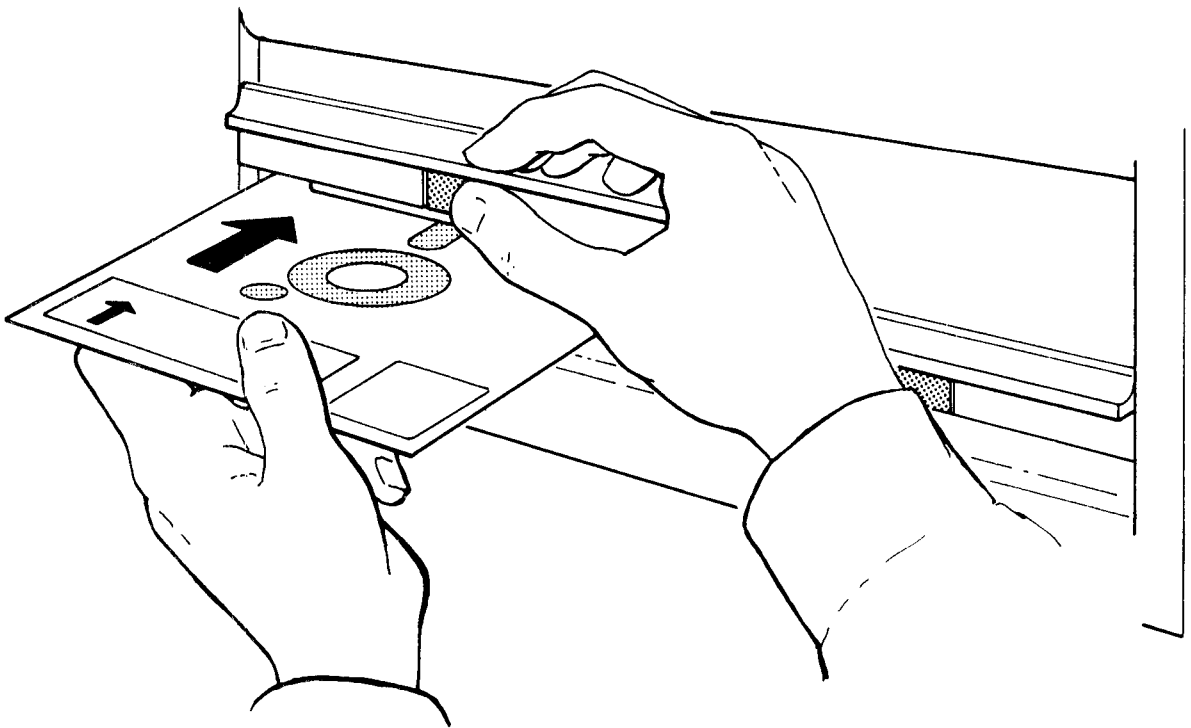

08-1519

Figure 2-5 Inserting System Diskette in Drive

3. Insert your document diskette into the right drive (drive one) the same way you inserted the system diskette.

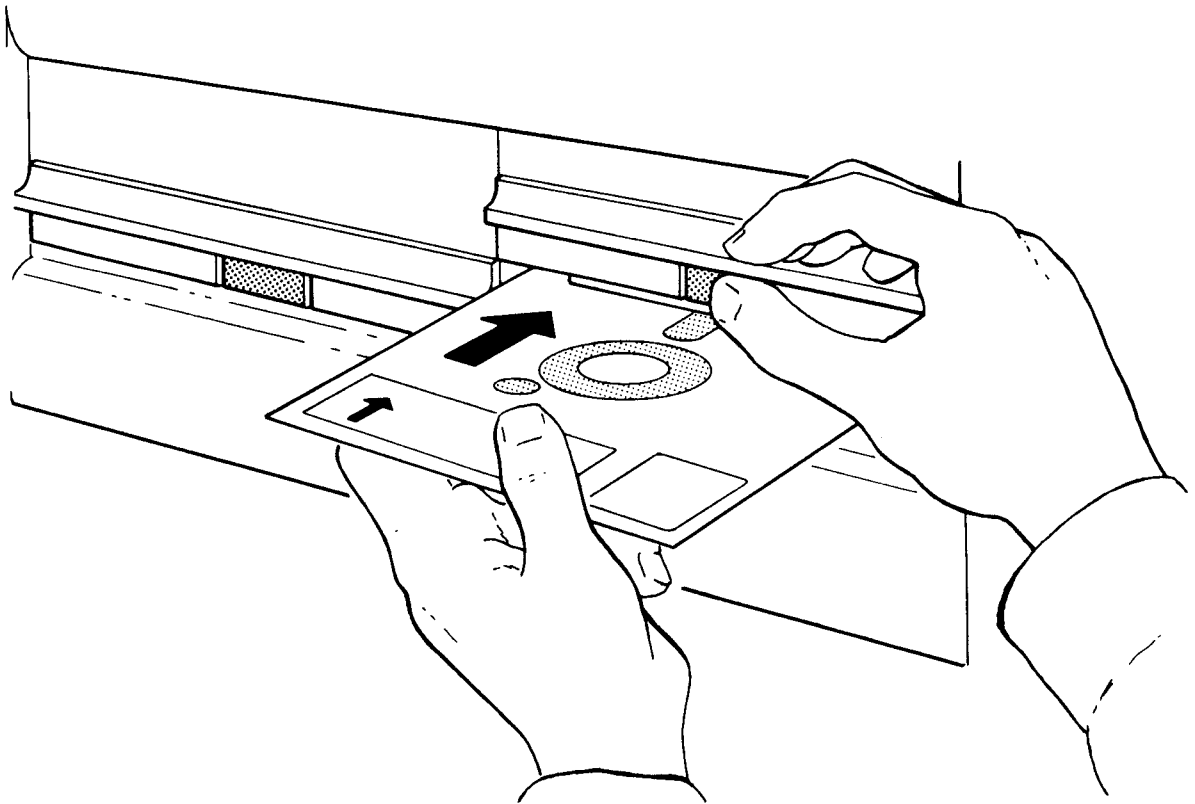

08-1530

Figure 2-6 Inserting Document Diskette
in Drive

2.4 TYPING THE DATE AND TIME

After inserting the diskettes, press the RETURN key (located on the right of the main keyboard). The characters "ABC" will briefly be displayed on the screen and will be followed by the word processing Date/Time Menu.

```
-- DATE/TIME MENU --                                0/0/00 ... 0:01:26

Digital Equipment Corporation WPS-8 Word Processing System
WS100 Version 2.7

Please type the date and time as follows:
mm/dd/yy hh:mm
Example:
12/1/75 9:25

Errors can be corrected by pressing RUB CHAR.
When done, press RETURN.
```

9113-30R4-A0068

Figure 2-7 WS100 Date/Time Menu

Respond to the prompt by typing today's date and the present time and then press the RETURN key. Be sure to follow the format and spacing as the Date/Time Menu instructs and to use the number 1 instead of the letter l. It is preferable to use a 24 hour clock (for example, type 5 p.m. as 17:00).

If you make a mistake before pressing the RETURN key, press the RUB CHAR OUT key (second row, upper right of the main keyboard). Pressing RUB CHAR OUT causes a back space and erases the character to the left of the cursor. To remove the entire date or time, press the RUB WORD OUT key (located just left of the RUB CHAR OUT key). This causes a back space and erases the word to the left of the cursor.

If you don't specify the date and time correctly, the following message will be displayed on the screen:

Date/Time typed incorrectly. Try again.

Retype the date and time and press the RETURN key.

You may omit typing the date or time and just press the RETURN key. No harm will be done, but your bookkeeping will not be entirely accurate. The word processing system keeps an index in which it records when you use each document (among other information). Therefore, if you don't specify a date, the word processing system cannot record the correct bookkeeping information.

Before going further, look at the white/black contrast on your screen. If it is too bright or too blurry, you can adjust it with the INTENSITY CONTROL switch (located on the back of the terminal).

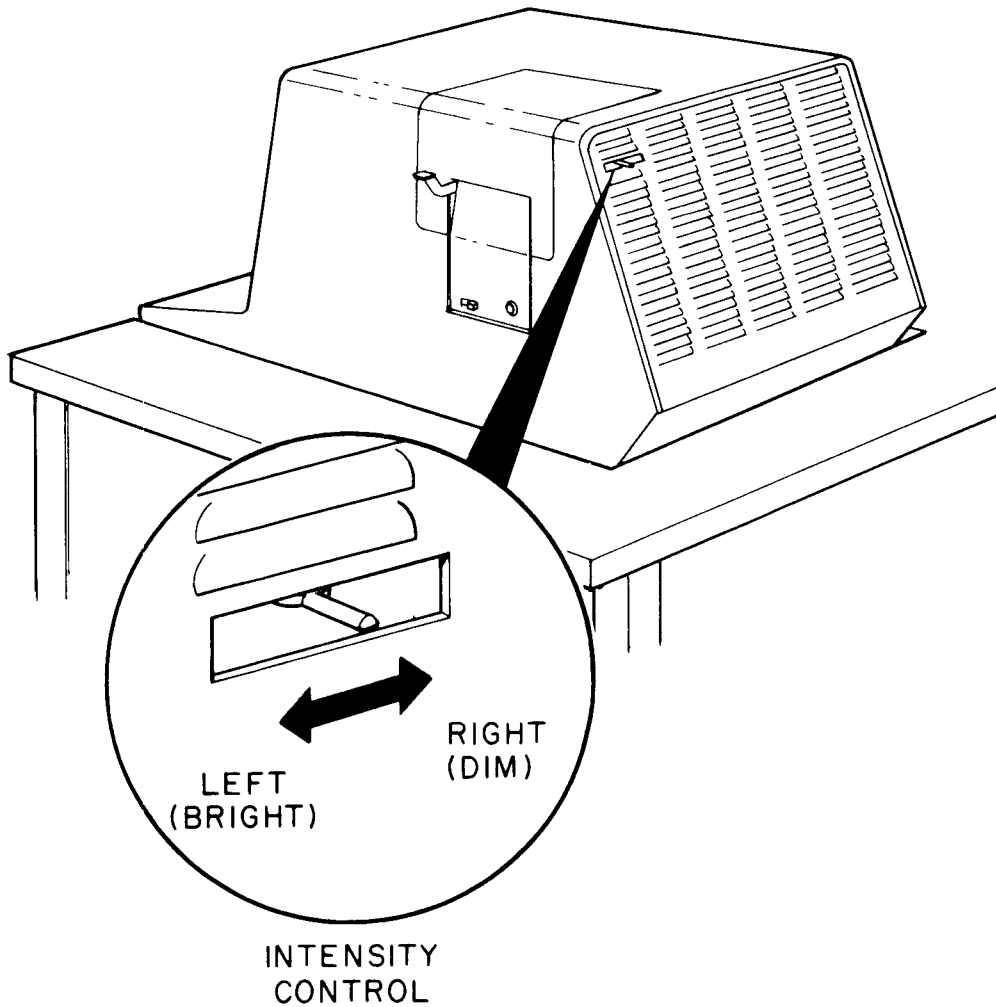

08-1560

Figure 2-8 WS100 Intensity Control Switch

2.5 MAIN MENU

After you type the date and time, the first page of the Main Menu will be displayed on the screen. Notice that the date and time are displayed in the upper right corner. The day of the week (abbreviated to three letters) and the time in seconds are also displayed there. If you should be working at midnight, the screen display will automatically change to reflect the new date and time (provided you specified the time in 24 hourclock format).

The Main Menu lists the special options of the word processing system. To perform any option, type its letter(s) and press the RETURN key.

Because the system provides so many different options, there are several pages to the Main

Menu. To display each successive page, type the letter M and press the RETURN key. If you type M and press the RETURN key when the last Main Menu page is on the screen, the first page will be displayed again. For a complete listing of all Main Menu options, refer to Appendix B.

You can type any Main Menu option regardless of what Main Menu page is displayed. For example, if you have completed your word processing work, you can type P (to Print a document) and press the RETURN key even if the second or third Main Menu page is displayed.

```
-- MAIN MENU --                                1/24/78 Tue 9:06:00

C = Create a new letter or document
E = Edit an existins letter or document
P = Print a letter or document
I = Index of letters and documents on file
F = Finished using the system
M = More main menu selections...

Type the letter and then press RETURN.
```

9113-3R1-A0069

Figure 2-9 Main Menu Page One (Version 2.7)

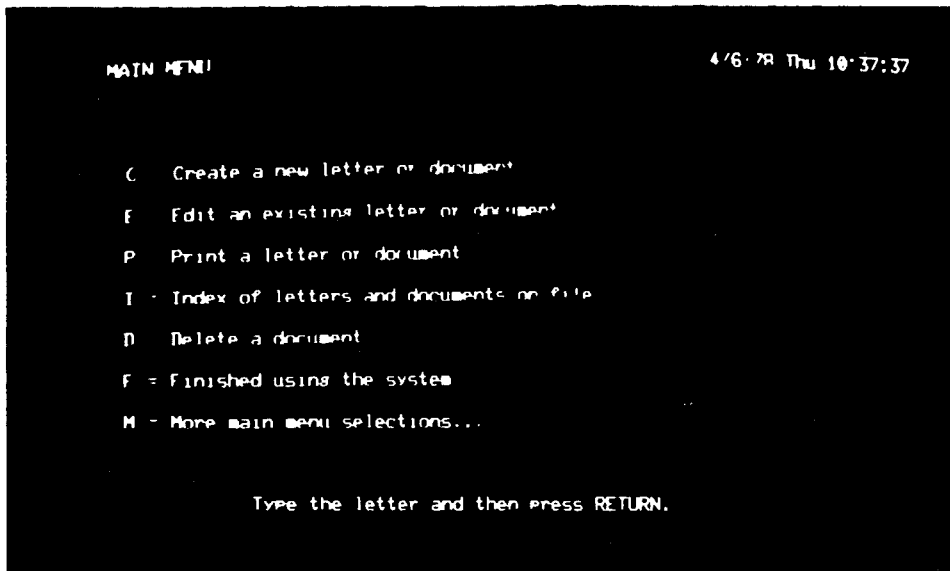

M113-12A0385

Figure 2-9 Main Menu Page One (Version 3.0)

2.6 RESETTING THE DATE AND TIME

The RD Main Menu option allows you to reset the date and time. This is useful if you accidentally type the wrong date or time (if it's January 1977 and you're still in the habit of typing 1976). To reset the date or time, type the letters RD

(when any Main Menu page is displayed on the screen) and press the RETURN key. The Date/Time Menu is displayed once again. You can now proceed to type the correct date and time.

2.7 STOPPING

When you are finished using the word processing system, type the letter F (for Finished) and press the RETURN key. The following message is displayed on the screen:

If you intend to take a lengthy break and no one else wants to use the word processing system, remove your diskettes and turn off the machine to conserve energy.

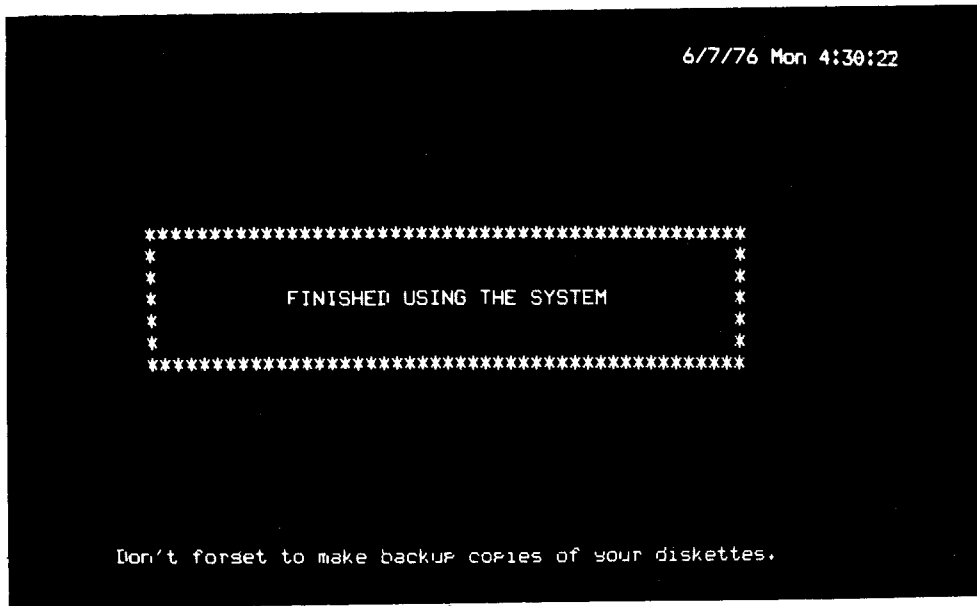

8018-78-A0067

Figure 2-10 Finished Message

2.8 POWER FAILURES AND BROWN-OUTS

If the power supply to your WS100 system ever fails, you will not lose any typing. When the power comes on again, do the following:

1. If the screen does not display your previous work, press the ON/OFF switch once to turn the machine off and a second time to turn it back on again. If you previously had been viewing a menu, you must also press the gold and the MENU keys.

2. Verify your diskettes to make certain no electrical damage was done (see Section 17.2.3).
3. If the power was off for a long time, reset the date and time (see Section 2.6). Otherwise you will still be using the old time (when power failed).

If the system ever stops responding to your typing, you have a brown-out, a momentary drop in power supply. To proceed with your work, press the ON/OFF switch twice and then verify your diskettes (see Section 17.2.3).

CHAPTER 2 OPERATING THE WS102 AND WS202 EQUIPMENT

The WS102 and WS202 word processing systems consist of hardware and software. *Hardware* is the actual equipment you can see – the keyboards, the display screen, the diskette drives, and the computer. *Software* is computer programs that allow you to operate the equipment in a particular way. The word processing software allows you to type text, correct errors, save the text for using again, and print what you've typed.

To start up the WS102 and WS202 word processing system, you must make both the hardware and the software operational. Start up requires two diskettes: (1) a system diskette, which contains the WS102 software, and (2) a document diskette, which contains (or will contain) the documents you create and edit. If you don't already have these diskettes, see your System Manager.

You can start the WS102 and WS202 only from the terminal connected to the top two diskette drives (numbered zero and one). This terminal is referred to as the main terminal in this chapter.

In summary, to start up the WS102 and WS202 hardware and software, you follow these steps:

1. Press the ON/OFF switches to supply electrical power to the hardware (see Section 2.1).
2. Press the appropriate switches to bootstrap, or activate, the software (see Section 2.2).
3. Insert the system and document diskettes (see Section 2.3).
4. Press the RETURN key once to display the Start Menu (see Section 2.4).
5. Press the RETURN key again to display the Date/Time Menu, type today's date and the time, and press the RETURN key (see Section 2.5).

Once you start up the hardware and software, the Main Menu is displayed on the screen. This menu gives you a selection of word processing work you may perform. See Section 2.6 for how to use the Main Menu.

2.1 TURNING ON THE MACHINE

If you see some words or a blinking underscore character on the screen, the machine is on already. All you have to do is bootstrap, insert the diskettes, and type the date and time (see Sections 2.2 - 2.5). You can do this provided (1) no one is using the other terminal and (2) no one has left the main terminal unattended (with work in process). It is available if the screen displays either the message "FINISHED USING

THE SYSTEM" or some instructions that begin with "MAIN MENU."

To turn on the machine, follow these steps:

1. Make sure the ON/OFF switch (black, located on the side of each terminal) which supplies power to the display screen is in the ON position.

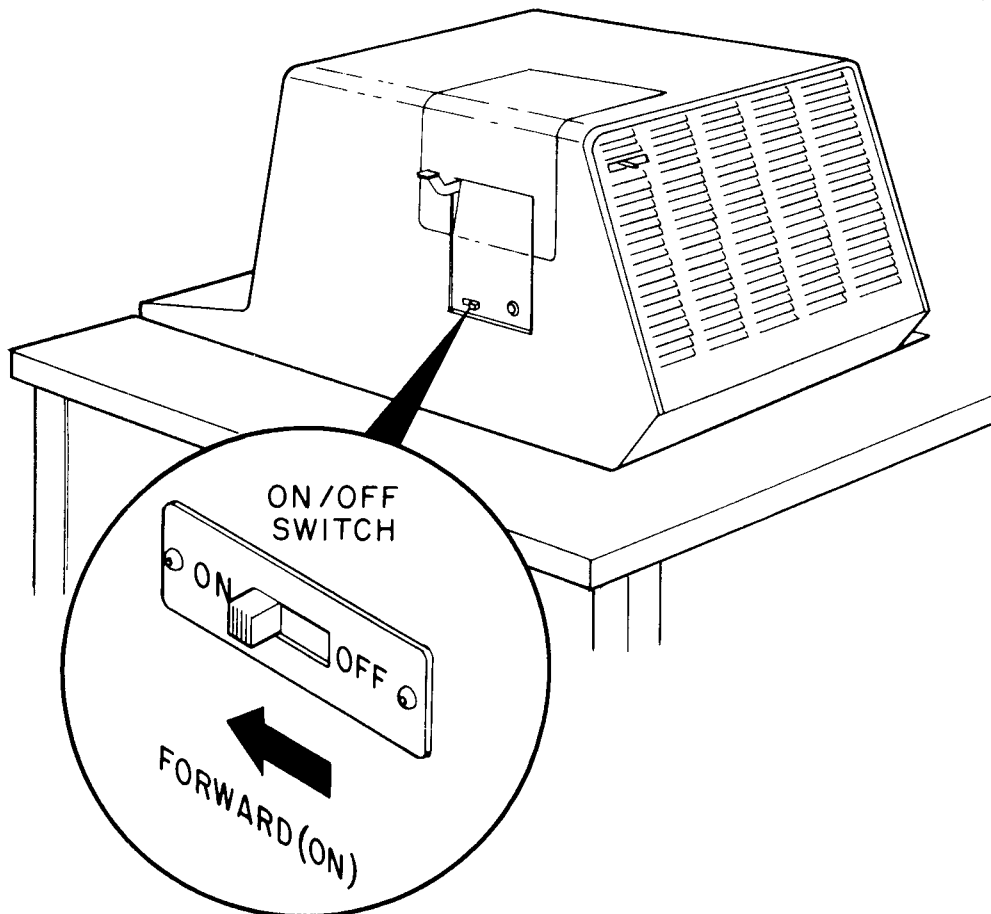

08-1558

Figure 2-1 WS102 Display Screen Switch

2. Push in the ON/OFF switch which supplies power to the entire system. The WS102 ON/OFF switch is red and is located on the front of the main terminal. The WS202 ON/OFF switch is white and the middle of three switches on the top of the diskette drive cabinet. The word processing system will start to hum. If nothing happens, check that the power plug is securely in the wall socket. (If it is and your

system still does not respond, call your DIGITAL Field Service Representative.)

See Figure 2-2a for the WS102 and Figure 2-2b for the WS202.

After the system warms up, the cursor (a blinking underscore character) will appear in the upper left corner of each terminal's screen.

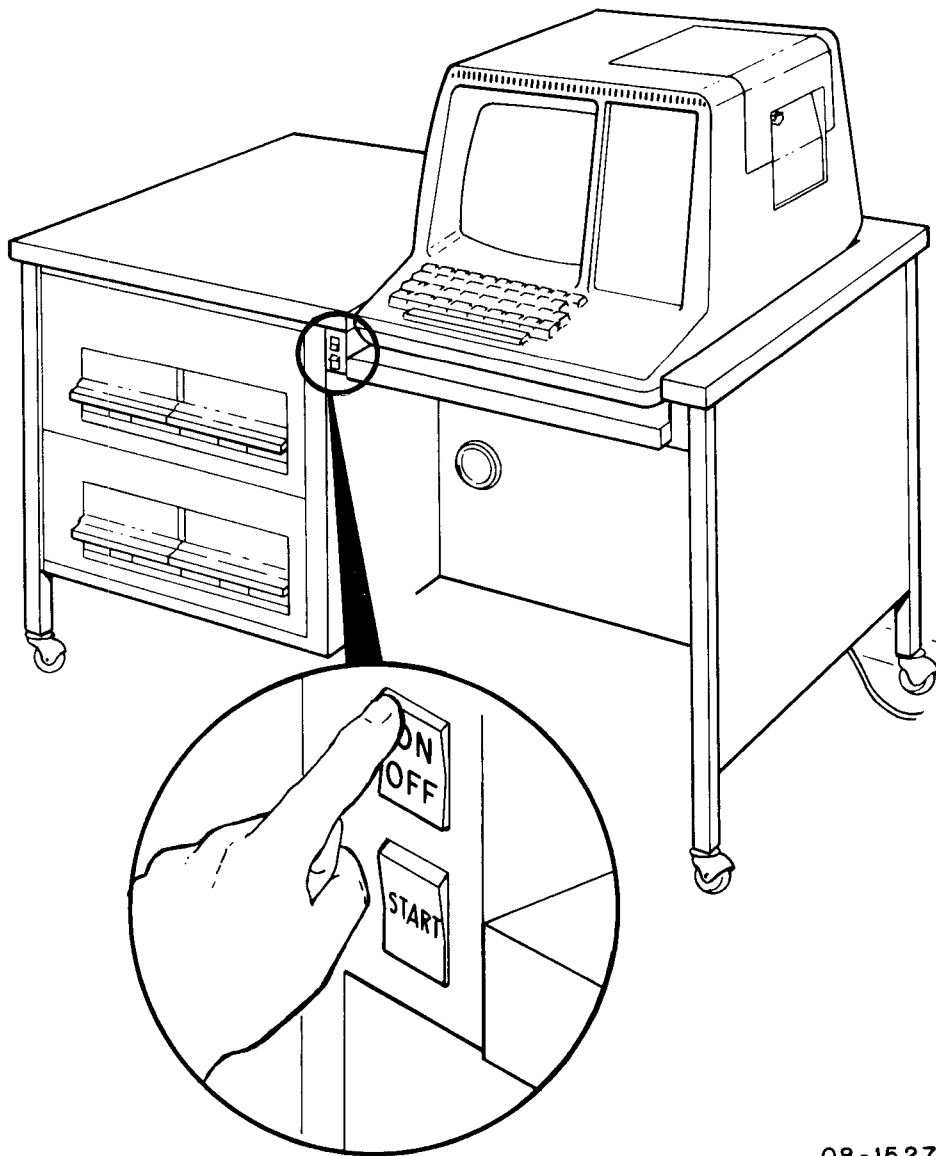

08-1527

Figure 2-2a WS102 ON/OFF Switch

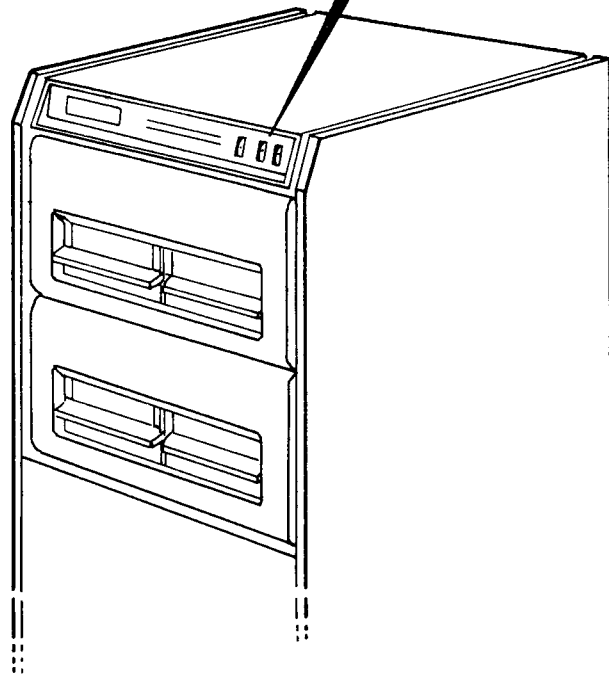
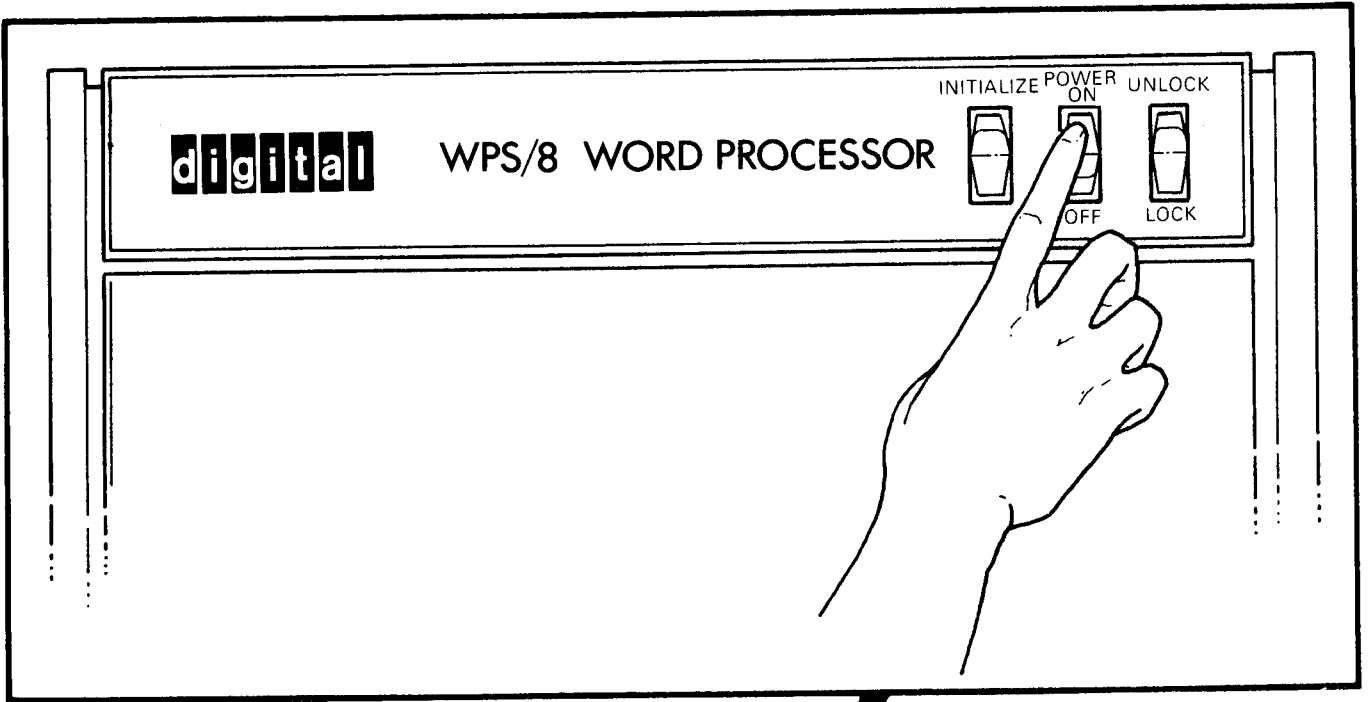

MK-0189

Figure 2-2b WS202 ON/OFF Switch

2.2 BOOTSTRAPPING

The first step in starting up the software is called *bootstrapping*. This term is derived from the adage "Pull yourself up by your bootstraps." Technically speaking, bootstrapping means to put a small program into the computer memory which, in turn, inserts a larger program.

To bootstrap the WS102 system, press the white START switch located on the front of the main terminal right beneath the ON/OFF switch. To bootstrap the WS202 system, push the rightmost

switch on the top of the diskette drive cabinet to the UNLOCK position. While holding that switch, press the leftmost switch to the INITIALIZE position.

When bootstrapping is complete, the characters "0123" will be displayed in the upper left of the main terminal's screen. The other terminal's screen will display the cursor.

See Figure 2-3a for the WS102 and Figure 2-3b for the WS202.

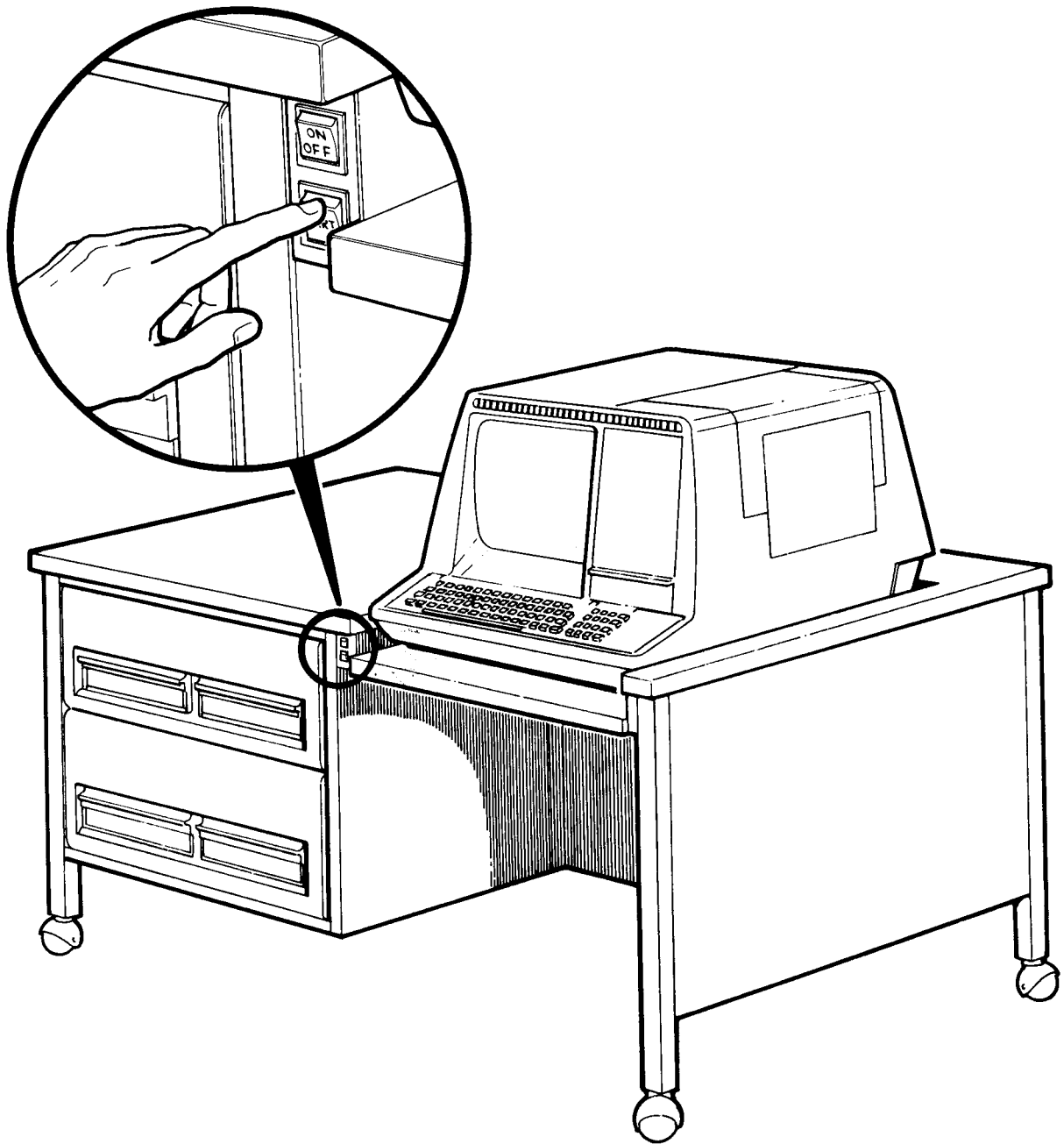

MK-0069

Figure 2-3a WS102 START Switch

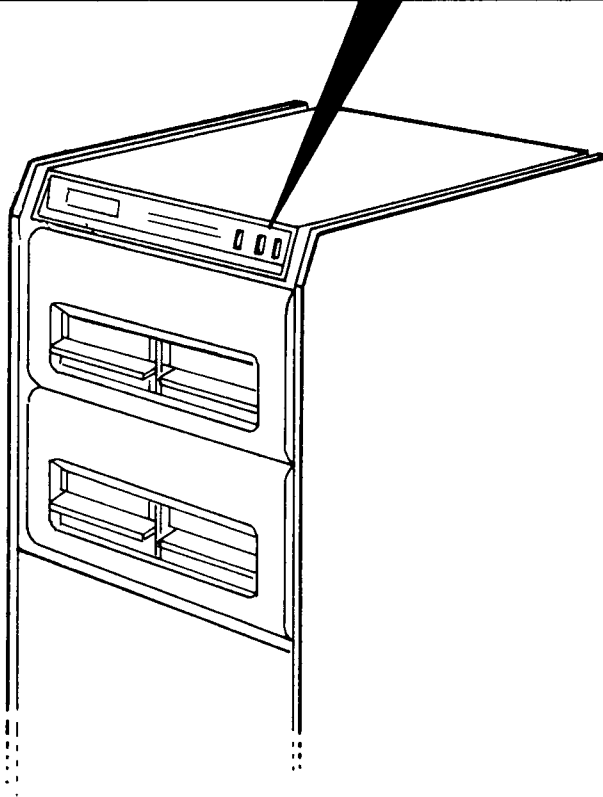
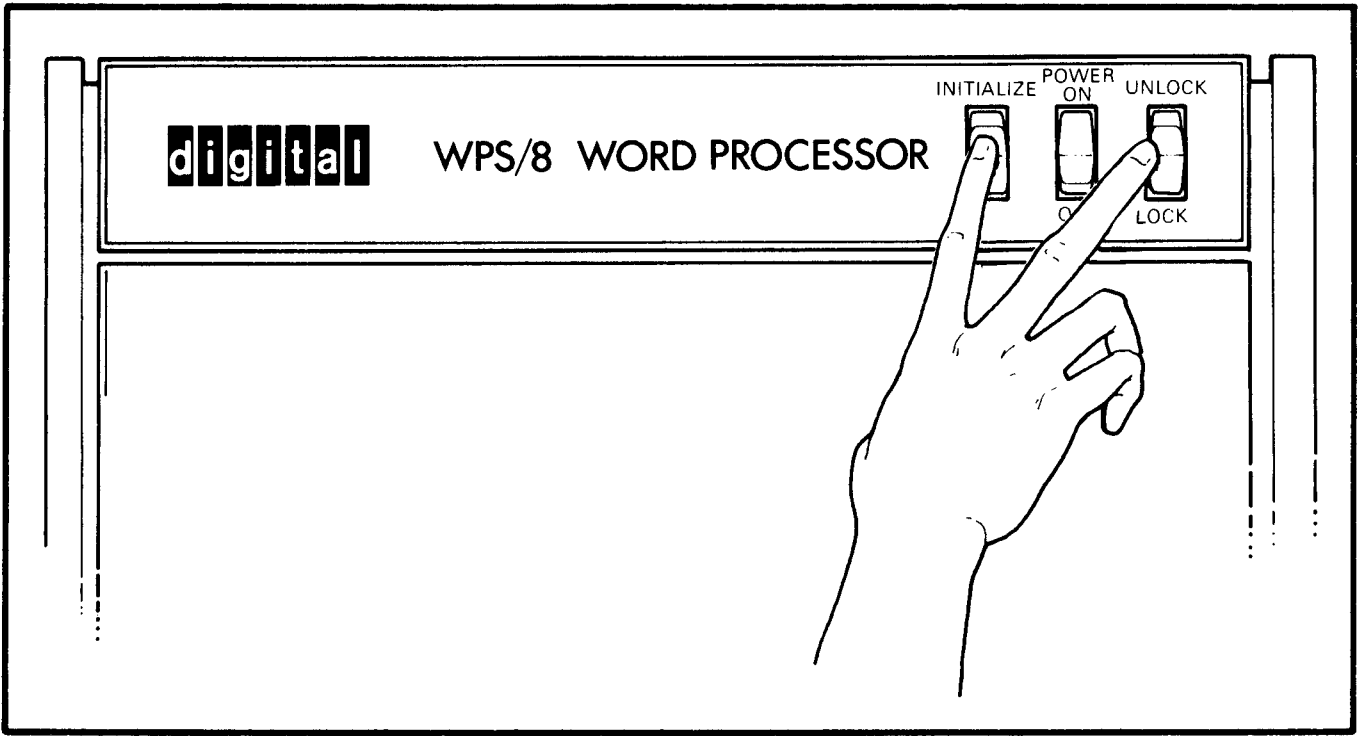

MK-0187

Figure 2-3b WS202 START Switch.

2.3 INSERTING THE DISKETTES

A diskette is a round piece of magnetic material about the size of a 45-rpm record, kept inside a nonremovable square protective cover. The diskette and protective cover fit into a special envelope when not in use.

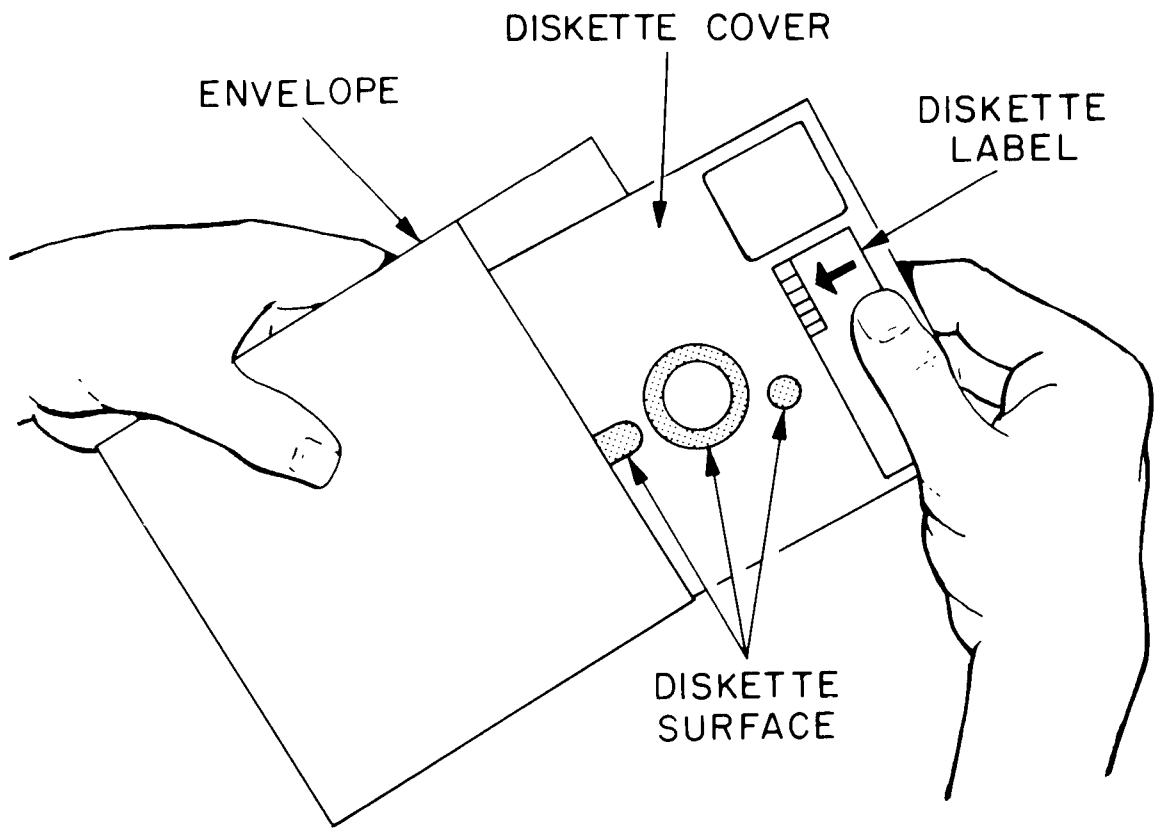

CP-3234

Figure 2-4 Diskette

To operate the WS102 and WS202 word processing systems, insert your system diskette into the top left diskette drive (drive zero) and your document diskette into the top right (drive one) by following these steps:

1. Open the diskette drives by squeezing the handles with your thumb and forefinger. If

either already contains a diskette (left there by the previous user), remove it.

2. Remove the system diskette from its envelope and insert it into the top left diskette drive (drive zero). Push down on the handle until it snaps shut.

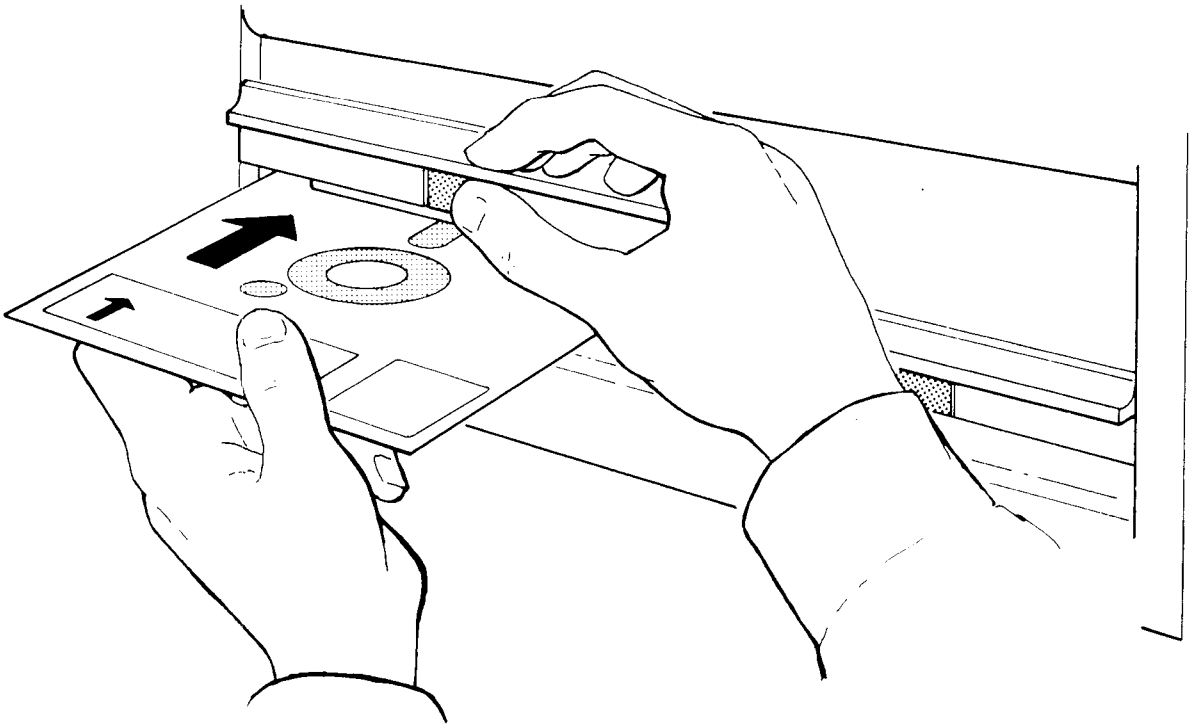

08-1519

Figure 2-5 Inserting System Diskette in Drive

3. Insert your document diskette into the top right drive (drive one) the same way you inserted the system diskette.

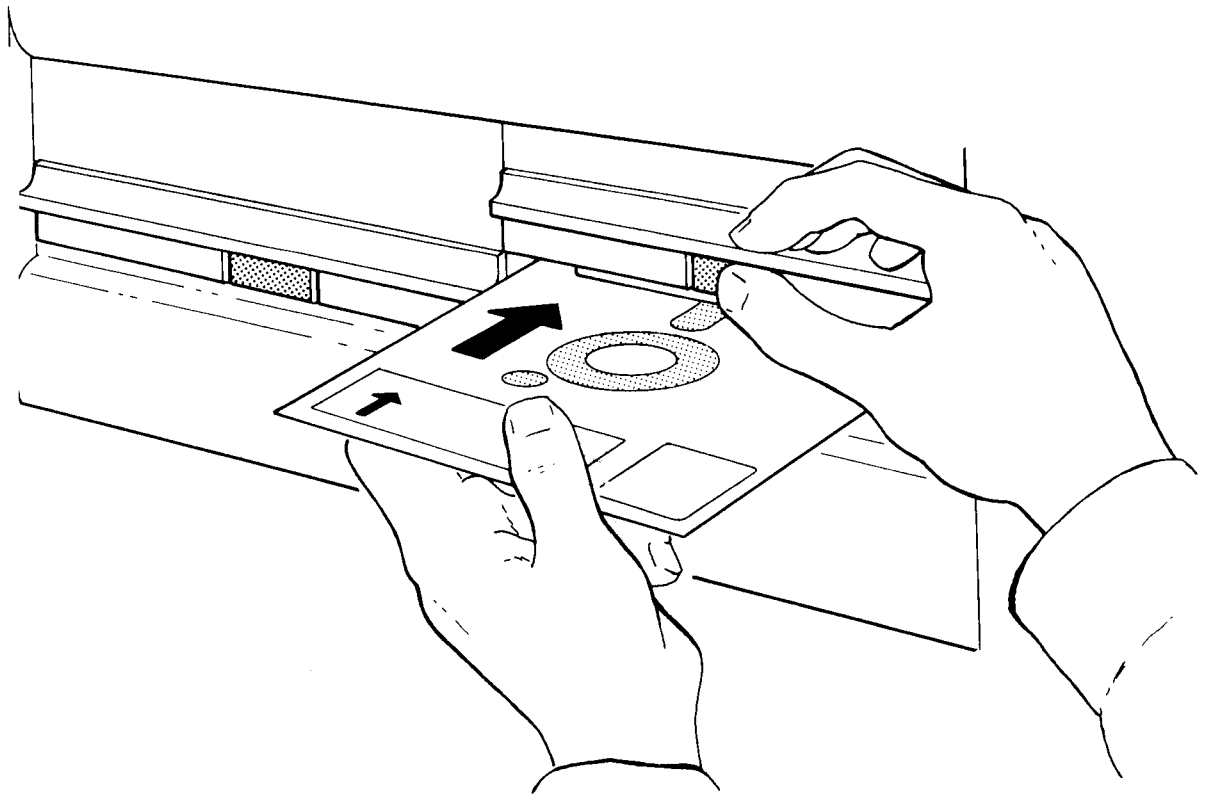

08-1530

Figure 2-6 Inserting Document Diskette
in Drive

2.4 START MENU

After inserting the diskettes, press the RETURN key (located on the right of the main terminal's keyboard). The characters "ABC" will briefly be

displayed on the main terminal's screen. Then the word processing Start Menu will be displayed on each screen. Here is how the main terminal's screen appears:

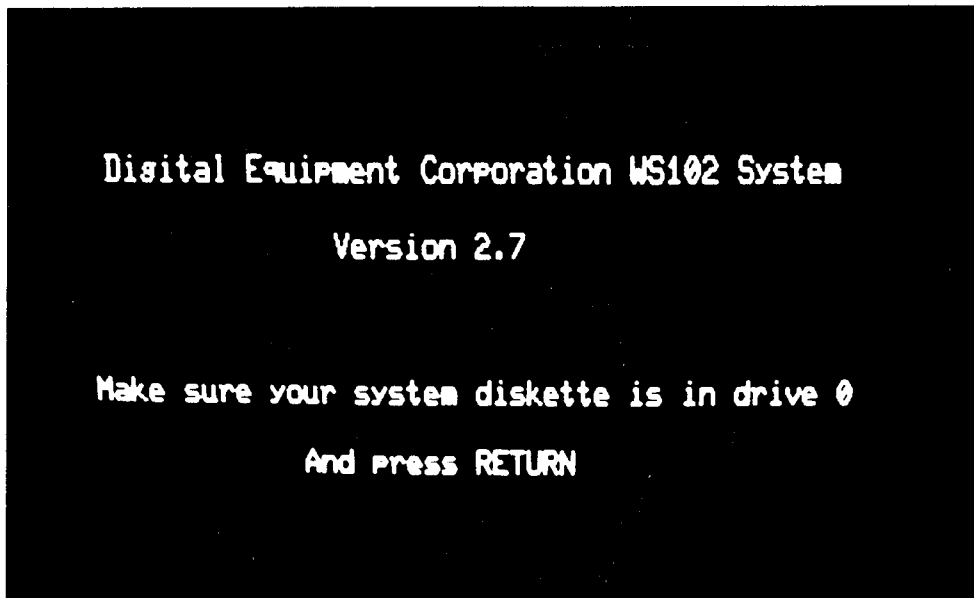

9113-31R4-A0070

Figure 2-7a WS102 Start Menu

Digital Equipment Corporation WS102 System

Version 3.0

Make sure your system diskette is in drive 0

And press RETURN

M113-8A0384

Figure 2-7b WS202 Start Menu

For the other terminal, the number 2 will appear on the screen instead of the number 0 (in the next to last line) for a WS102 system and the number 1 for a WS202 system.

Before going further, look at the white/black contrast on your screen. If it is too bright or too blurry, you can adjust it with the INTENSITY CONTROL switch (located on the back of the terminal).

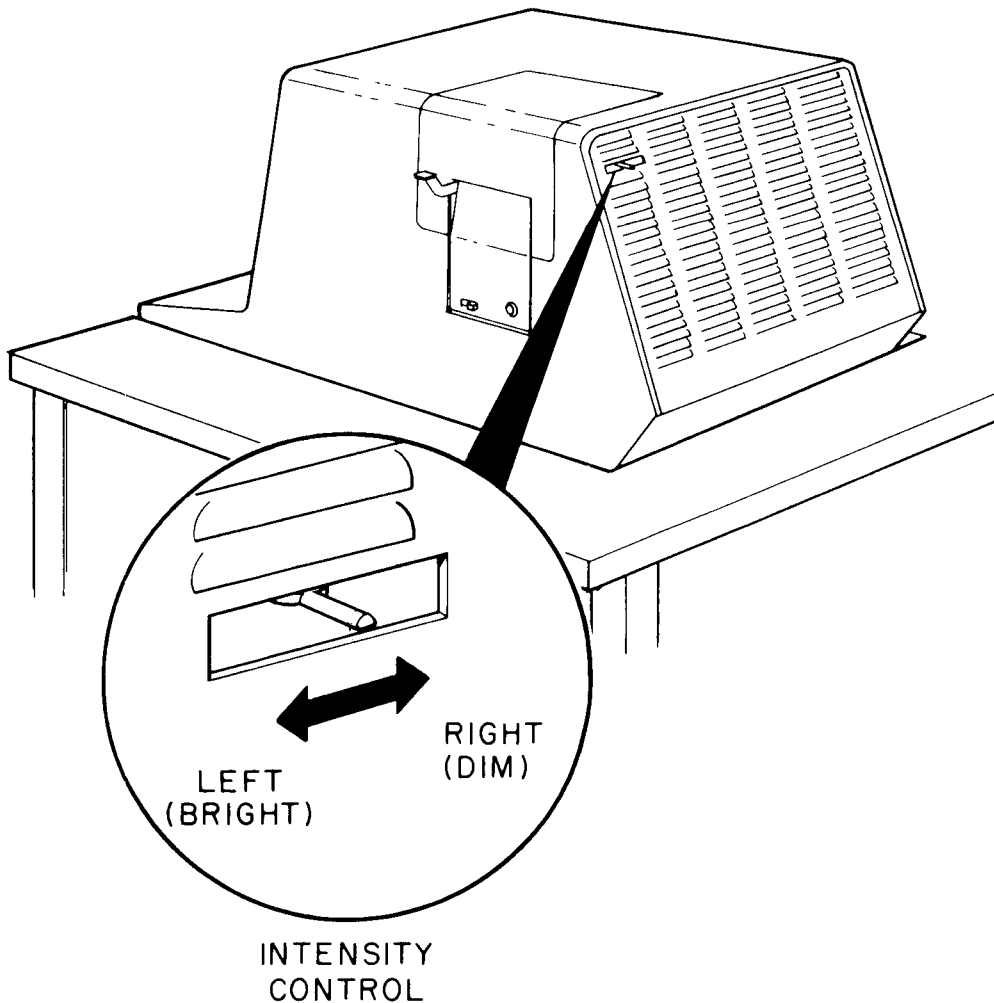

08-1560

Figure 2-8 WS102 Intensity Control Switch

2.5 TYPING THE DATE AND TIME

After you press the RETURN key in response to the Start Menu prompt, the word processing Date/Time Menu will be displayed on your screen (the other terminal's screen will continue displaying the Start Menu).

```
— DATE/TIME MENU —                               1/24/78 Tue 9:10:13

Digital Equipment Corporation MPS-8 Word Processing System
WS102 Version 2.7

Please type the date and time as follows:
      mm/dd/yy hh:mm

Example:
      12/1/75 9:25

Errors can be corrected by pressing RUB CHAR.
When done, press RETURN.
```

9113-19R1-A0071

Figure 2-9 WS102 Date/Time Menu (Version 2.7)

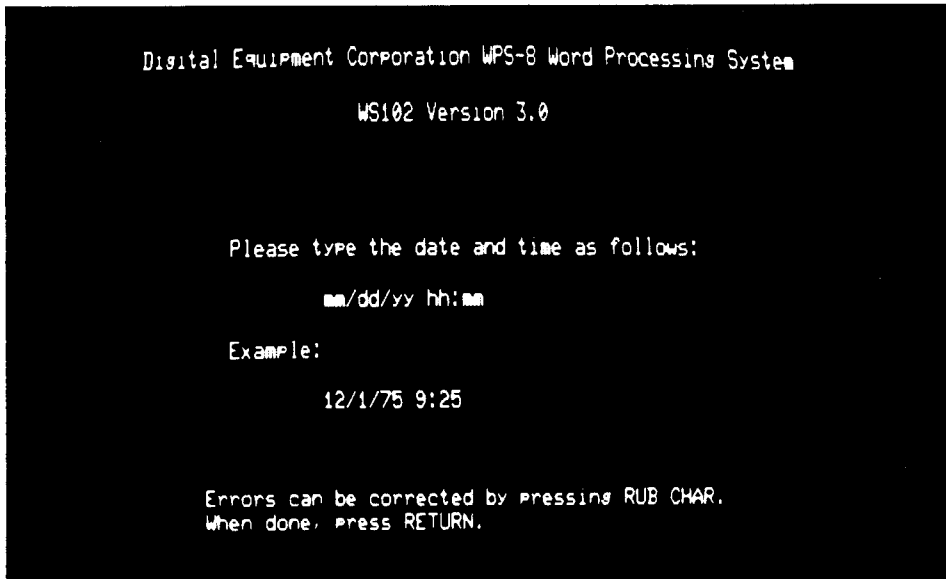

M113-9A0392

Figure 2-9 WS102 Date/Time Menu (Version 3.0)

Respond to the prompt by typing today's date and the present time from either terminal and then pressing the RETURN key. Be sure to follow the format and spacing as the Date/Time Menu instructs and to use the number 1 instead of the letter l. It is preferable to use a 24 hour clock (for example, type 5 p.m. as 17:00).

If you make a mistake before pressing the RETURN key, press the RUB CHAR OUT key (second row, upper right of the main keyboard). Pressing RUB CHAR OUT causes a back space and erases the character to the left of the cursor. To remove the entire date or time, press the RUB WORD OUT key (located just left of the RUB CHAR OUT key). This causes a back space and erases the word to the left of the cursor.

If you don't specify the date and time correctly, the following message is displayed on the screen:

Date/Time typed incorrectly. Try again.

Retype the date and time and press the RETURN key.

You may omit typing the date or time and just press the RETURN key. No harm will be done, but your bookkeeping will not be entirely accurate. The word processing system keeps an index in which it records when you use each document (among other information). Therefore, if you don't specify a date and time, the word processing system cannot record the correct bookkeeping information.

2.6 MAIN MENU

The first page of the Main Menu is automatically displayed on the main terminal screen after you type the date and time. In order for the Main Menu to be displayed on the screen of the other terminal, that user must press the RETURN key.

Notice that the date and time are displayed in the upper right corner. The day of the week (abbreviated to three letters) and the time in seconds are also displayed there. If you should be working at midnight, the screen display will automatically change to reflect the new date and time (provided you specified the time in 24 hour clock format).

The Main Menu lists the special options of the word processing system. To perform any option, type its letter(s) and press the RETURN key.

Because the system provides so many different options, there are several pages to the Main Menu. To display each successive page, type the letter M and press the RETURN key. If you type M and press the RETURN key when the last Main Menu page is on the screen, the first page will be displayed again. For a complete listing of all Main Menu options, refer to Appendix B.

You can type any Main Menu option regardless of what Main Menu page is displayed. For example, if you have completed your word processing work, you can type P (to Print a document) and press the RETURN key even if the second or third Main Menu page is displayed.

```
— MAIN MENU —                               1/24/78 Tue 9:06:00

C = Create a new letter or document
E = Edit an existing letter or document
P = Print a letter or document
I = Index of letters and documents on file
F = Finished using the system
M = More main menu selections...

Type the letter and then press RETURN.
```

9113-3R1-A0069

Figure 2-10 Main Menu Page One (Version 2.7)

```
-- MAIN MENU --                                4/6/78 Thu 10:37:37

C = Create a new letter or document
E = Edit an existing letter or document
P = Print a letter or document
I = Index of letters and documents on file
D = Delete a document
F = Finished using the system
M = More main menu selections...

Type the letter and then press RETURN.
```

M113-12A0385

Figure 2-10 Main Menu Page One (Version 3.0)

2.7 RESETTING THE DATE AND TIME

The RD Main Menu option allows you to reset the date and time from either terminal. This is useful if you accidentally type the wrong date or time (if it's January 1977 and you're still in the habit of typing 1976).

To reset the date or time, type the letters RD (when any Main Menu page is displayed on the screen) and press the RETURN key. The Date/Time Menu will be displayed once again. You can now proceed to type the correct date and time. The new date and time will take effect on both terminals.

2.8 STOPPING

When you are finished using the word processing system, type the letter F (for Finished) and press the RETURN key. The following message is displayed on the screen:

If you intend to take a lengthy break and no one else wants to use the word processing system, remove your diskettes and turn off the machine to conserve energy.

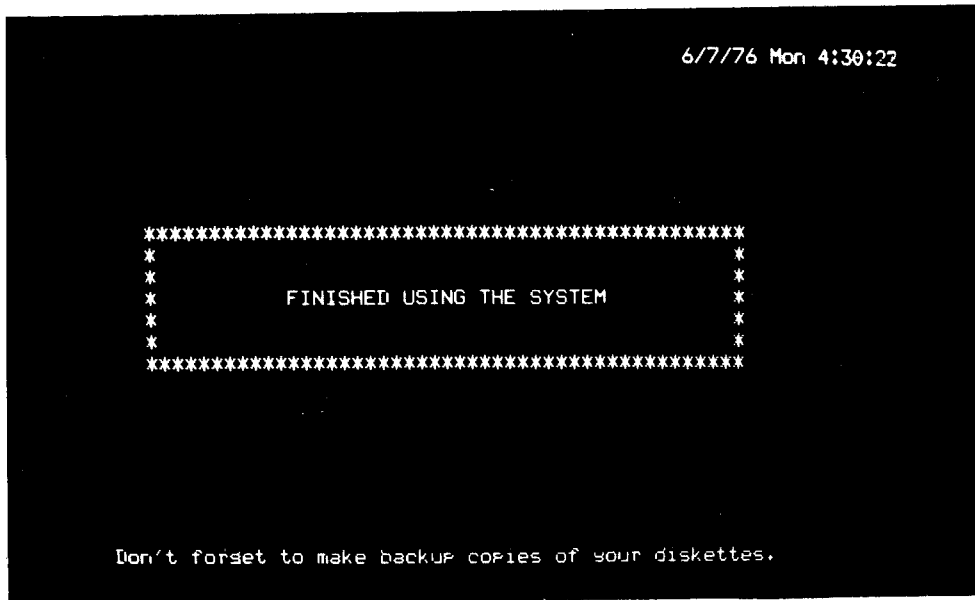

8018-78-A0067

Figure 2-11 Finished Message

2.9 POWER FAILURES AND BROWN-OUTS

If the power supply to your WS102 system ever fails, you will not lose any typing. When the power comes on again, do the following:

1. If the screen does not display your previous work, press the ON/OFF switch once to

turn the machine off and a second time to turn it back on again. If you previously had been viewing a menu, you must also press the gold and the MENU keys.

2. Verify your diskettes to make certain no electrical damage was done (see Section 17.2.3).

3. If the power was off for long time, reset the date and time (see Section 2.7). Otherwise you will still be using the old time (when power failed).

If the power supply to your WS202 system ever fails, you may lose approximately one page of your most recent typing. When power is restored, do the following:

1. Bootstrap the system once again (see Section 2.3).
2. Verify your diskette to make certain no electrical damage was done (see Section 17.2.3).

If the system ever stops responding to your typing, you have experienced a brown-out, a momentary drop in power supply. To proceed with your work, press the ON/OFF switch twice and then verify your diskettes (see Section 17.2.3).

CHAPTER 3 CREATING A DOCUMENT

The process of telling the word processing system you want to type some new text is called creating a new document. To the word processing system a document is a unit of storage. The system saves documents on your diskette in much the same way as you save reports in a file cabinet drawer: it uses the document name just like a projecting file folder label. When creating a document, you give the document a name and the system gives you essentially a “clean sheet of paper” on which to type.

When you create a document, you will do the following:

1. Tell the word processing system the document name (see Section 3.1).
2. Type your text (see Section 3.2).

3. File the document onto your diskette (see Section 3.3).

3.1 HOW TO CREATE A DOCUMENT

To create a new document, type the letter C (for Create) when any Main Menu page is displayed on the screen and press the RETURN key. The screen will display a message asking you to name your document.

Now type the name you want to assign to the document and press the RETURN key.

You can save time creating a document by typing the letter C, a space, the document name, and pressing the RETURN key. When you use this method, the screen display asking for a document name is omitted.

9/30/77 Fri 10:51:03

Type the name to be given to the document you wish to create
and press RETURN

OR Press Gold MENU to recall the Main Menu.

8920-15R1-A0074

Figure 3-1 Document Create Prompt

3.1.1 Naming a Document

A document name must conform to these requirements:

1. No more than 60 characters can be used.
2. First character must be a letter.
3. Second through last characters can be any letters, numbers, punctuation marks, or spaces except for the left and right angle brackets (< and >).
4. The name must be unique – you can't already have a document with this name on your diskette. If you use the same name twice, the word processing system will display an error message asking for another name. Also, you cannot use one or more words of a document's name as the complete name for another. For example, if you have a document named "quarterly report," you may not name another document "quarterly."
5. No extra spaces are allowed before or after a document name (before pressing the RETURN key).

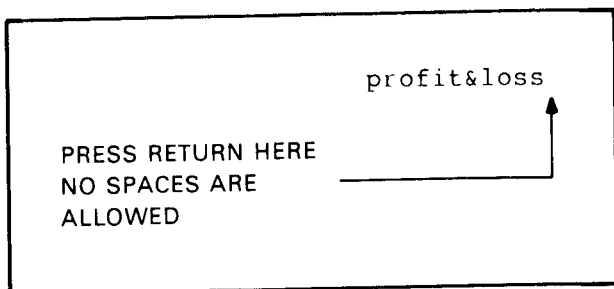

MK-0073

Figure 3-2 Document Name Example

Though not a requirement, it's a good idea to give your documents meaningful names. For example, "profit&loss" is more meaningful than "p&l" while "profit&loss, March 1977" is even more specific.

3.1.1.1 Correcting a Typo in the Document Name

Name – If you make a mistake before pressing the RETURN key, press the RUB CHAR OUT key (second row, upper right of the main keyboard). Pressing RUB CHAR OUT causes a backspace and erases the character to the left of the cursor.

You can remove a word in the document name (or the entire name if it does not contain spaces) by pressing the RUB WORD OUT key (to the left of the RUB CHAR OUT key). Pressing this key causes a back space and erases the word to the left of the cursor. For example, if you type the following

c Smith memo3/30/77

and then discover the memo recipient's name is really spelled Smyth, press the RUB WORD OUT key once, the RUB CHAR OUT key three times, and retype the correct document name.

3.1.1.2 Document Storage Location – When you create a document you have the option of specifying where you want to store it: on either the system or the document diskette. The word processing system assumes you intend to use the document diskette unless you specify otherwise.

To store a document on the document diskette, just type a document name after typing the letter C. To store a document on the system diskette, type the { character in front of the document name.

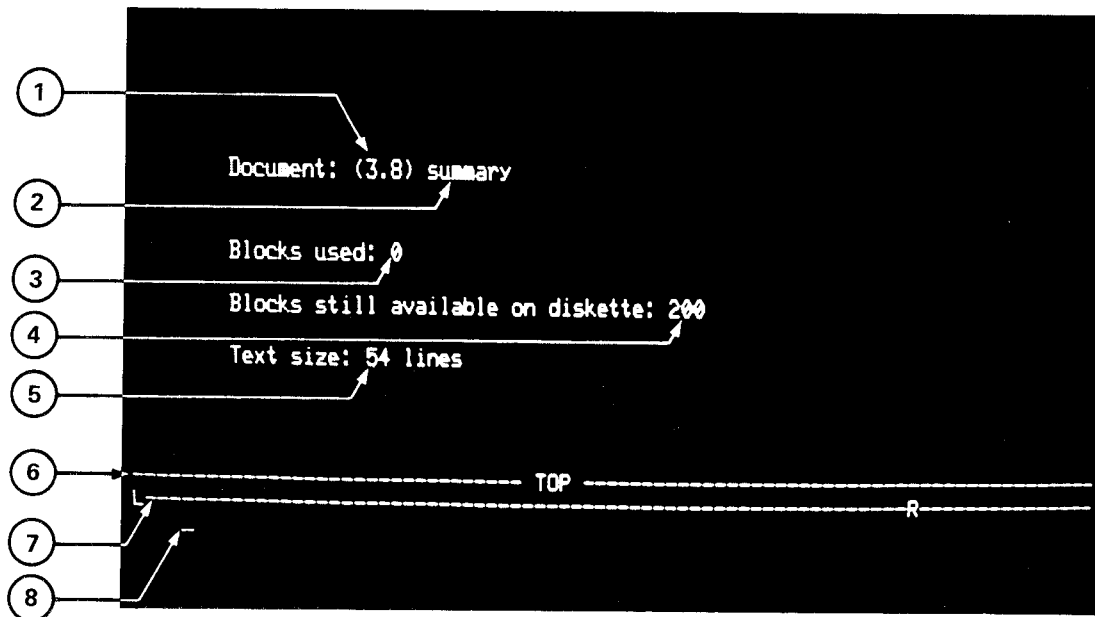

8920-16R1-A0073

Figure 3-3 Example of Screen Display When Creating a Document

If you are operating a system that contains four diskette drives, you have two additional drives available for document storage. Appendix C.1 supplies details for how to store documents in these systems.

3.1.2 Screen Display When a Document Is Created

Here is an example of the screen display when you create a new document:

- ① **Diskette drive number and document number.** The first number identifies the diskette drive where the document is stored. The possible values are 0 or 1 for a system with two diskette drives and 0, 1, 2, or 3 for a system with four

drives. The drive number is followed by a period and the document's number which was automatically assigned by the word processing system.

- ② **Document name.** This is the document name you specified.
- ③ **Amount of storage space used.** Storage space is measured in units called blocks, approximately 500 typed characters or one paragraph. As you haven't yet typed a single character, this position contains zero.
- ④ **Amount of storage space available.** This is the number of blocks still available

for document storage on your diskette. If this number is less than 25, you should either delete any obsolete documents from the diskette or use another diskette.

- ⑤ **Preset text size.** The word processing system will automatically put 54 lines of text on each page typed. You may change this to accommodate different sizes of paper (see Section 12.4).
- ⑥ **Top marker.** This marks the top of your text.
- ⑦ **Preset ruler.** This contains left and right margin settings, tabs, and vertical line spacing. The ruler you see when you create a document may differ from the one in the example above (see Section 6.5 for how to change a preset ruler).

- ⑧ **Cursor.** The cursor is a blinking underscore character which marks your current position in the document. As you haven't yet typed anything, the cursor is positioned at the beginning of your document.

3.2 TYPING NEW TEXT

You type text into the word processing system with the black keys on the main keyboard. These keys contain the letters, numbers, punctuation marks, and other special characters in the same positions as on an ordinary typewriter.

The main keyboard also has some extra keys, and some of the keys can be used to perform special gold-lettered functions only when the gold key on the mini keyboard is first pressed. Appendix A.1 presents a complete description of all main keyboard keys.

3.2.1 Ending Lines: Word Wrap Versus Hard Return

The word processing system automatically "word wraps" lines you type. That is, if a word cannot fit at the end of one line, the system automatically inserts a carriage return (called automatic or word wrap) and moves the word to the next line. Press the RETURN key only when you don't want text to be word wrapped, such as at the end of a paragraph or an entry in a table or list. This type of carriage return is referred to as a hard return.

Carriage returns – both word wrap and hard – are not displayed on the screen as you type. Sometimes you may need to know which type you have (perhaps you think you may have accidentally pressed the RETURN key). You can inspect your typing for carriage returns by viewing the text (see Appendix D). When you view text, an automatic or word wrap return is displayed as a \circ symbol. A hard return is displayed as a \downarrow symbol.

Here is an example of viewed text showing both word wrap and hard carriage returns:

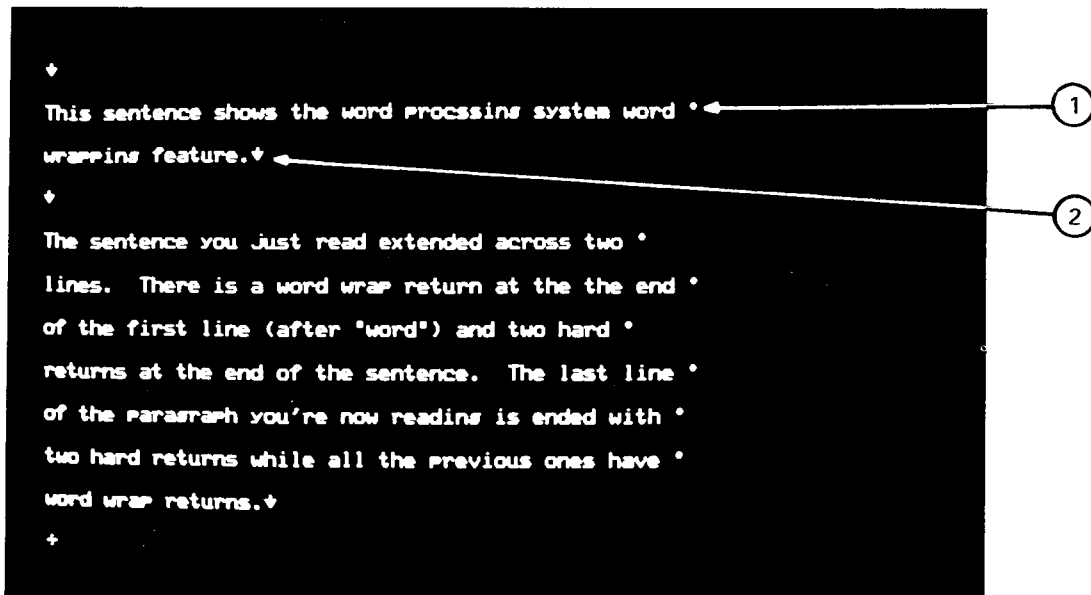

- ① WORD WRAP RETURN
- ② HARD RETURN

9113-21R1-A0072

Figure 3-4 Viewed Text Showing Word Wrap and Hard Carriage Return

Pressing the RETURN key inserts a mark for a hard return into your document. While this mark is not displayed on the screen (except when you view text), it nevertheless occupies one typing position. Therefore, you can remove it from your text with either the DEL CHAR or RUB CHAR OUT key.

3.2.2 Removing Errors Just Typed

If you notice an error as you are typing, you can remove it with the main keyboard RUB CHAR OUT, RUB WORD OUT, RUB LINE, or RUB SENT key. Each time you press one of these four keys, the word processing system removes the corresponding item to the immediate left of the cursor.

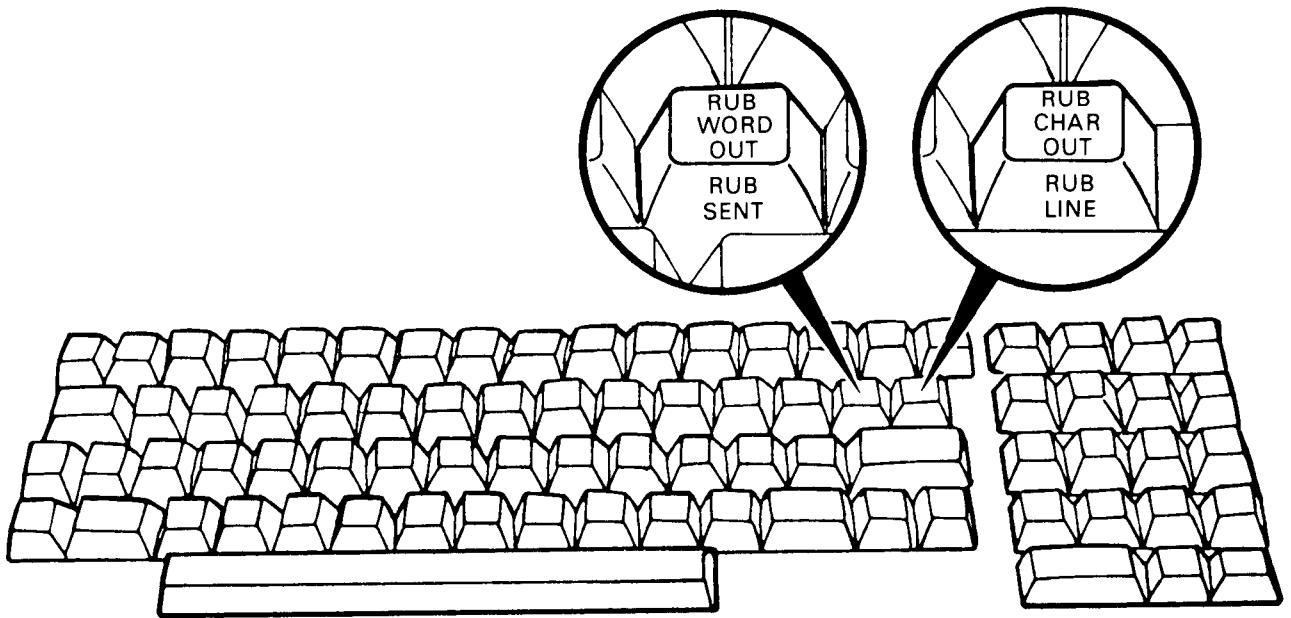

MK-0074

Figure 3-5 Main Keyboard RUB WORD OUT, RUB SENT, RUB CHAR OUT, RUB LINE Keys

You can also make other changes anywhere in your text. You can insert additional material, delete, or make other changes. Refer to Sections 5.2 - 5.4 for details.

3.2.3 Leaving Vertical Space for Insertions

If you need to leave vertical space for insertions,

such as a drawing or photograph, just press the RETURN key six times for each inch (when single-spacing is used). If you are not certain how many times you pressed RETURN, view your typing (by pressing the gold and VIEW keys) and count the number of symbols that appear. Each corresponds to a single pressing of the RETURN key.

3.2.4 Centering, Underlining, and Boldfacing

You can center, underline, or boldface text at the same time as you type it. Refer to Chapter 8 for details.

3.2.5 Problem: Running Out of Storage Space While Typing

If the warning message

```
-- Do not add much more to document --  
Only "number" blocks left on diskette.  
Press Return
```

appears on the screen while you are typing (an actual value will appear instead of "number"), proceed only a few more lines to a point where you can stop and then file the document. Either

delete obsolete documents from the diskette or get another one (be sure it is initialized before using it – See Section 17.2.1), create a new document, and continue your typing. Mark the label of the first diskette to indicate it is full so you won't accidentally try to add text to it at some future time.

If you ignore the warning message, not only will you lose some of your typing, but you may also destroy other documents stored on the diskette.

3.3 FILING A DOCUMENT

Filing a document means to save it for using again. You must file a document when you are through typing in order to work with another document or to print what you just typed. To file a document, press the gold and the FILE DOCMT keys.

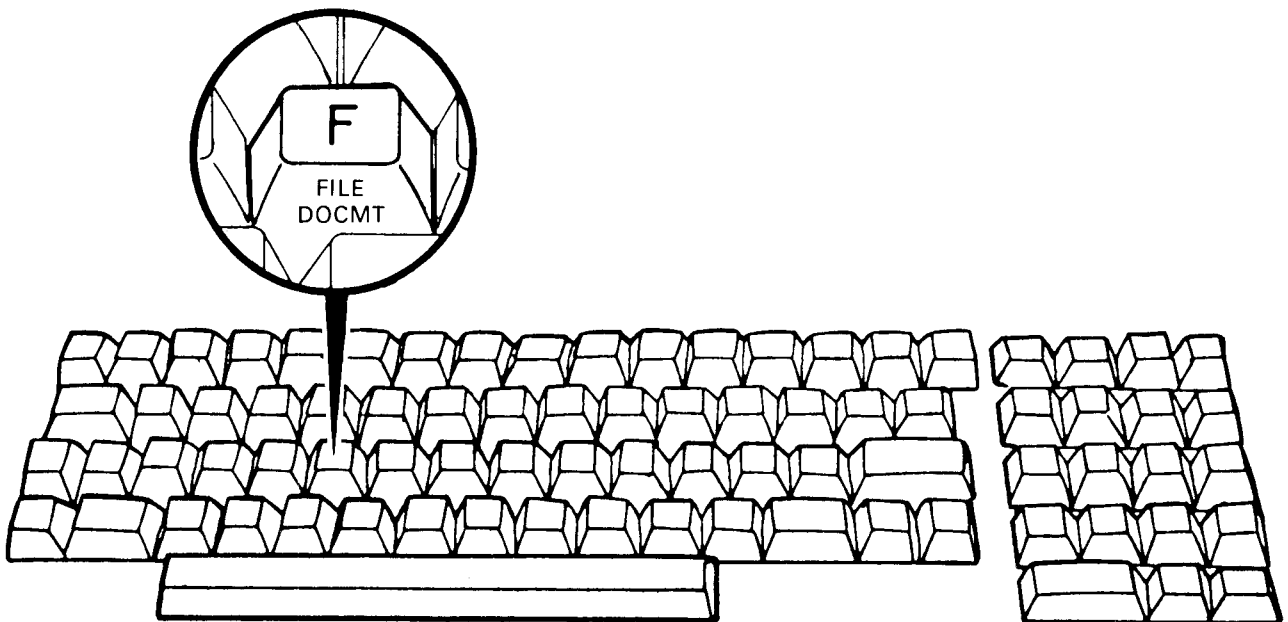

MK-0075

Figure 3-6 Main Keyboard FILE DOCMT Key

When you file a document the message

-- DOCUMENT FILING BEING COMPLETED --

is briefly displayed on the screen. After a few seconds the Main Menu is displayed on the screen (same page as was displayed when you directed the system to create a document).

The cursor can be located anywhere in a document – top, middle, or bottom – when you file.

CHAPTER 4 DOCUMENT INDEX

The word processing system maintains an index of all documents for each of your diskettes. The index is stored on each diskette and contains the following information.

- How much space is used and how much is available on the diskette.
- The name and number of each document.
- When each document was originally created and most recently modified.
- The size of each document.

- The amount of time used in the most recent editing session for each document plus the total amount of time spent editing.

4.1 EXAMINING THE INDEX

To examine the index for your document diskette, type the letter I (for Index) and press the RETURN key (when any Main Menu page is displayed on the screen). To examine the index for your system diskette, type the letter I and { character (space between the two is optional). If you are using a system that has four diskette drives, you may also examine the indexes of two additional diskettes. Refer to Appendix C.2 for details.

1/24/78 Tue 9:11:51

Drive: 3, Name: HELLO , # of Docs: 5, Blocks left: 439 (of 627)

Document Number	Name	Created	Modified	Size	Version	Elapsed Time Last	Total
6	index	1/5/78	1/16/78 9:54	3	2	0:00	0:00
5	Memo for basic information on preliminary plan	11/11/77	11/11/77 16:31	10	1	0:01	0:01
3	abbrv	11/4/77	11/4/77 11:12	1	3	0:01	0:05
2	intro part ii	11/2/77	11/7/77 10:07	168	22	0:06	4:43
1		11/2/77	1/16/78 9:53	1	9	0:00	0:00

Press RETURN to display more entries
OR Gold MENU to recall the Main Menu.

9113-23R1-A0075

Figure 4-1 Document Index Example

Here is an example of a document index:

- ① **Diskette drive number.** This is the number of the diskette drive whose index you are examining. The possible values are 0 or 1 for a system with two diskette drives and 0, 1, 2, or 3 for a system with four diskette drives.
- ② **Diskette name.** This is the name given to the diskette when it was initialized (see Section 17.2.1 for details).
- ③ **Total number of documents stored on your diskette.** You may have as many as 200 on a diskette.

- ④ **Amount of unused storage available.** This is specified in units called blocks, each of which contains approximately 500 characters or one paragraph. You can store as many as 627 blocks on the document diskette, fewer on the system diskette.
- ⑤ **Document number and name.** The documents are automatically listed in the order they were created, from the most recently-created to the first created. There are (at most) five listed on each index page displayed on the screen.

⑥ **Asterisk.** This appears in front of the first document entry. You can move it to an index entry and then direct the word processing system to let you edit, print, or delete that particular document. See Section 4.2 for how to use the asterisk.

⑦ **Creation date.** This is the date when you created the document. If you failed to specify a date when starting up the system, the characters

NO/DA/TE

will appear here.

⑧ **Modification date and time.** This indicates when you most recently edited the document. The same date appears here as in the creation date position if you failed to type a date when you started up the system and modified the document.

⑨ **Size.** This specifies the number of blocks used by the document on the diskette.

⑩ **Version number.** When you create and file a document, the system assigns it version number one. Each time you edit and file the document, the system increases the version number by one. This also happens each time you press the gold and TOP DOCMT keys.

⑪ **Amount of time in most recent use.** This is the amount of time spent the last time you used the document (creating, editing, examining, but not printing it). The time is specified in hours and minutes.

⑫ **Total amount of time.** This is the total of all time spent using the document (creating, editing, examining, but not printing it). The time is specified in hours and minutes.

⑬ **Document one.** This document is automatically created and maintained by the word processing system. It has no name. See Section 4.4 for details.

If the index contains more than five documents, the message

Press RETURN to display more entries

OR Gold MENU to recall the Main Menu.

is displayed at the bottom of each page. To see index information for the next five entries, do as the message says. Once you display the last index page, pressing the RETURN key will bring the Main Menu back on the screen.

4.2 USING THE INDEX

You can use the index when you want to edit, print, or delete a document and don't know the exact spelling of its name. You can also use it when you have a long document name to avoid typing it all out. Just move the asterisk character in the index to the document you want, by doing the following:

1. **Type the letter I and press the RETURN key** when any Main Menu page is displayed on the screen. This action displays the diskette index.
2. **Find the document you want in the index.**
3. **Press the ADVANCE key** (mini keyboard, white, left bottom) to move the asterisk in front of the document you want. Each time

you press the ADVANCE key, the asterisk advances to the next document entry. If you press ADVANCE when the asterisk is at the bottom of an index page (and there are more entries), the next index page will be displayed on the screen with the asterisk positioned in front of the first document entry. You can also move the asterisk backwards by pressing the BACK UP key (mini keyboard, white) through entries on the page being displayed. It is not possible to display a previous index page.

4. Press the gold and the MENU keys. A Main Menu page will now be displayed on the screen.

5. Edit, print, or delete the document which you marked by the asterisk.

4.3 PRINTING THE INDEX

Because the diskette index contains bookkeeping information about your documents, it's often useful to print it to have a record of your word processing activities. In order to print an index, you must first store it in a document, by doing the following:

1. Type the letters CI (for Copy Index) when any Main Menu page is displayed on the screen and press the RETURN key. The following prompt will be displayed.

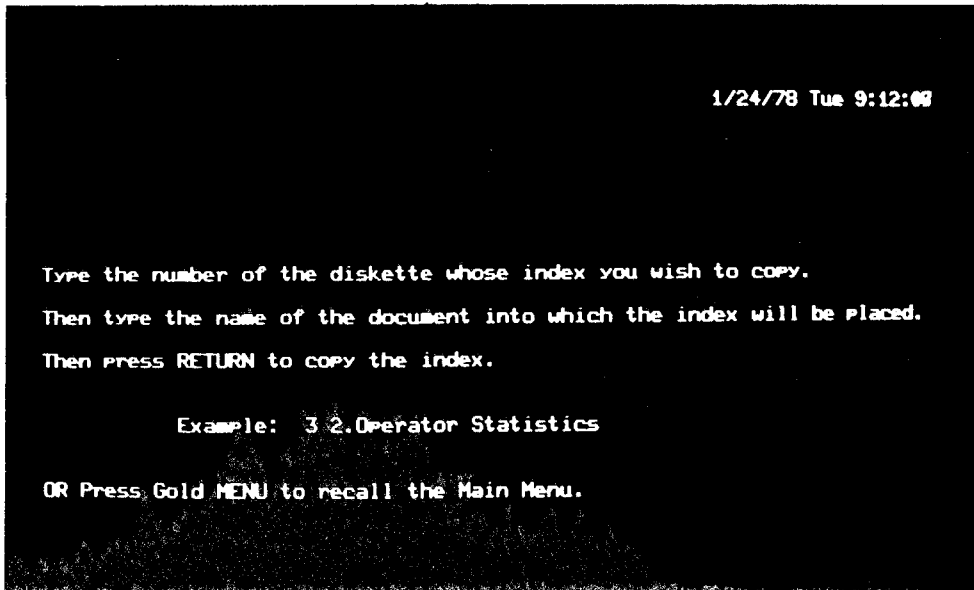

9113-25R1-A0076

Figure 4-2 Copy Index Prompt

2. Specify the diskette drive number whose index you want, type a space, identify the document to hold the index, and press the RETURN key. Use the following format:

You may omit specifying a drive number if you want the index of your document diskette or if you want to save the index on your document diskette.

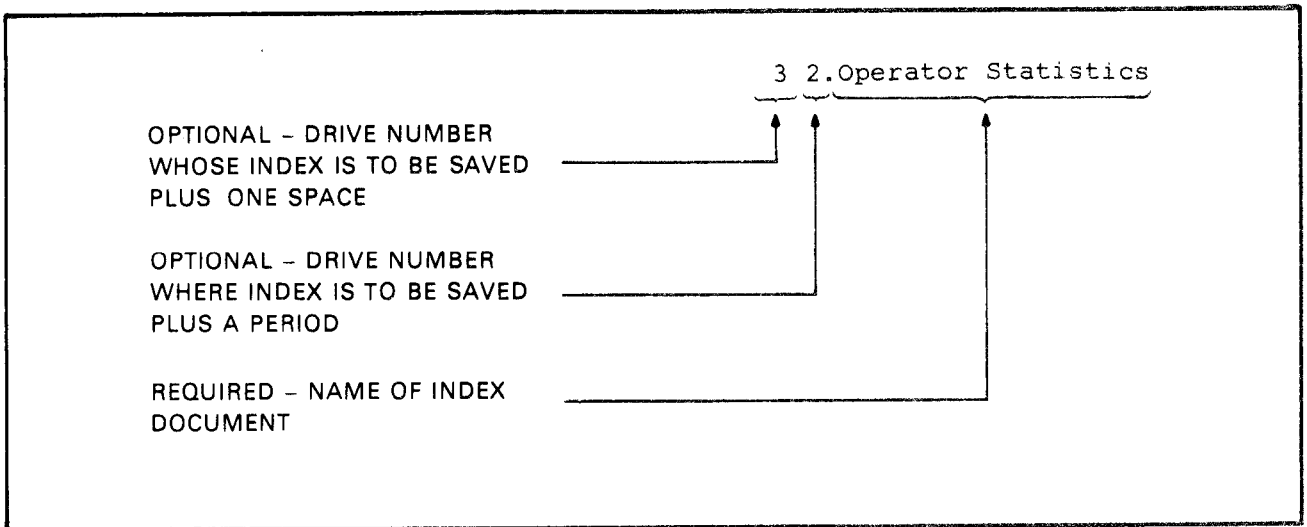

MK-0124

Figure 4-3 Example of Specifying Index Document

You may specify either a new document or one which already exists. If you specify a new document, the word processing system

will automatically create it. If you specify a document that already exists, the following prompt will be displayed on the screen.

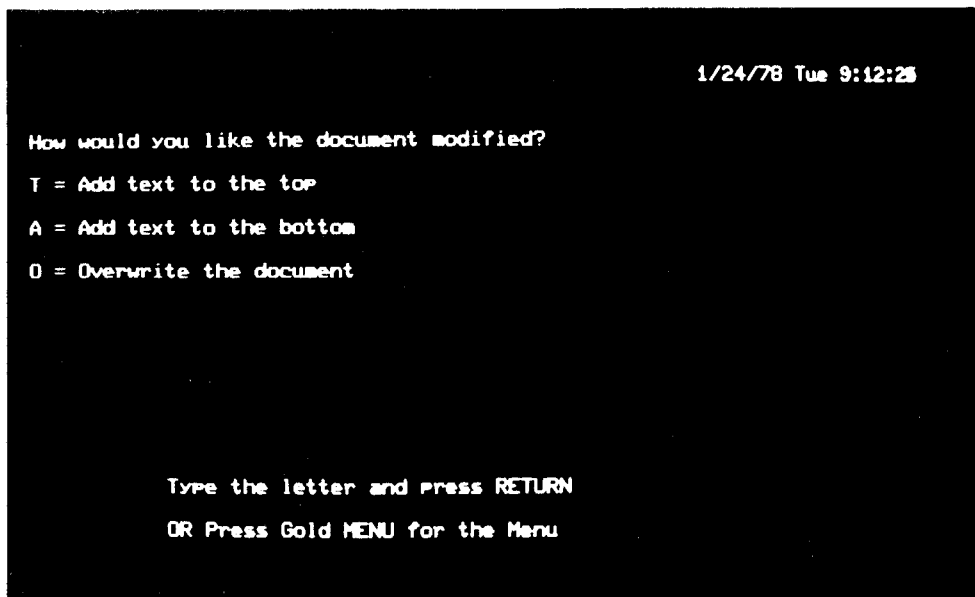

```
1/24/78 Tue 9:12:25  
  
How would you like the document modified?  
T = Add text to the top  
A = Add text to the bottom  
O = Overwrite the document  
  
Type the letter and press RETURN  
OR Press Gold MENU for the Menu
```

9113-27R1-A0077

Figure 4-4 Prompt for Modifying an Existing Index Document

This feature allows you to keep a “running index” by adding to a document that already contains other indexes. For example, you might want to save your index on a daily basis for a one-week period and print it on Friday. Every Monday you might want to start over again by replacing the previous week’s information. The index document will be displayed briefly on the screen. When complete, the Main Menu will again be displayed.

3. **Print the document** that contains the index (see Chapter 13). You can also edit the document before printing. This is useful if you want to delete some information or to add additional information, such as initials of the typists.

If you are using a system that has four diskette drives, you may save the indexes of two additional diskettes for printing. You may also use the two additional diskettes to save the index of

the system or document diskette. Refer to Appendix C.2 for details of specifying the two additional diskettes.

4.4 DOCUMENT NUMBER ONE: CHANGING THE SPELLING OF A DOCUMENT NAME

Document number one on each diskette is a list

of document names and corresponding numbers. The word processing system provides this document so that you can change the spelling of a document name: just change its spelling in document one (using any of the techniques described in Sections 5.3 and 5.4).

Here is an example of a document one:

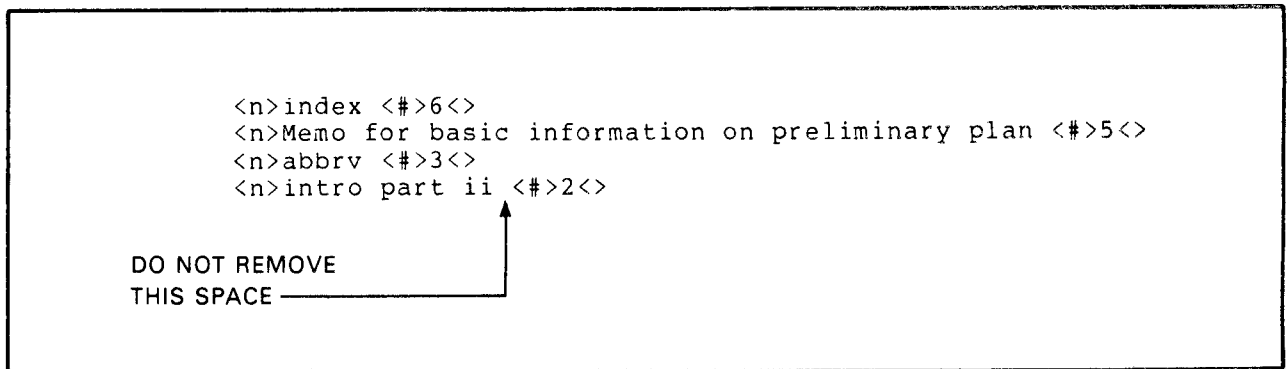

MK-0076

Figure 4-5 Example of Document One

Document number one is in a special format used by the word processing system. When editing document one, do not disturb the special format.

CHAPTER 5 EDITING A DOCUMENT

You can add new material or make changes to any document – one you are currently creating or one you previously stored on a diskette. You can also examine a portion of your document which is not currently displayed on the screen. Once you are through editing, file your document (see Section 3.3) to save your changes.

In summary, this chapter describes the following:

1. **How to bring a stored document to the screen.** In order to examine a document or to make changes to it, it must be on the screen. See Section 5.1 for details.
2. **How to move the cursor through the document that is currently on the screen.** You tell the word processing system where you want to insert additional material or where you want to make a change by moving the cursor to the desired location. To examine a portion of your document not currently displayed, you must move the cursor to the desired location. See Section 5.2 for details.
3. **How to insert additional material.** Typing additional material into a stored document

is probably one of the tasks you most frequently have to do. See Section 5.3 for details.

4. **How to make changes.** You can interchange two characters (change “hte” to “the”), delete single characters, words, or larger portions of text, and move a piece of text from one location to another. All changes are automatically stored on the diskette. See Section 5.4 for details.

If the warning message

-- Do not add much more to document --
Only “number” blocks left on diskette.
Press Return

appears on the screen while you are typing (an actual value will appear instead of “number”), proceed only a few more lines to a point where you can stop and then file the document. Either delete obsolete documents from the diskette or get another one (be sure it’s initialized before using it – see Section 17.2.1), create a new document, and continue your typing. Mark the label

of the first diskette to indicate it is full so you won't accidentally try to add text to it at some future time.

If you ignore the warning message, not only will some of your typing be lost, but you will also destroy some other documents stored on your diskette.

5.1 BRINGING AN EXISTING DOCUMENT TO THE SCREEN

To bring an existing document to the screen for editing, type the letter E (for Edit) when any Main Menu page is displayed on the screen and press the RETURN key. The screen will display a message asking you to identify the document you want to use.

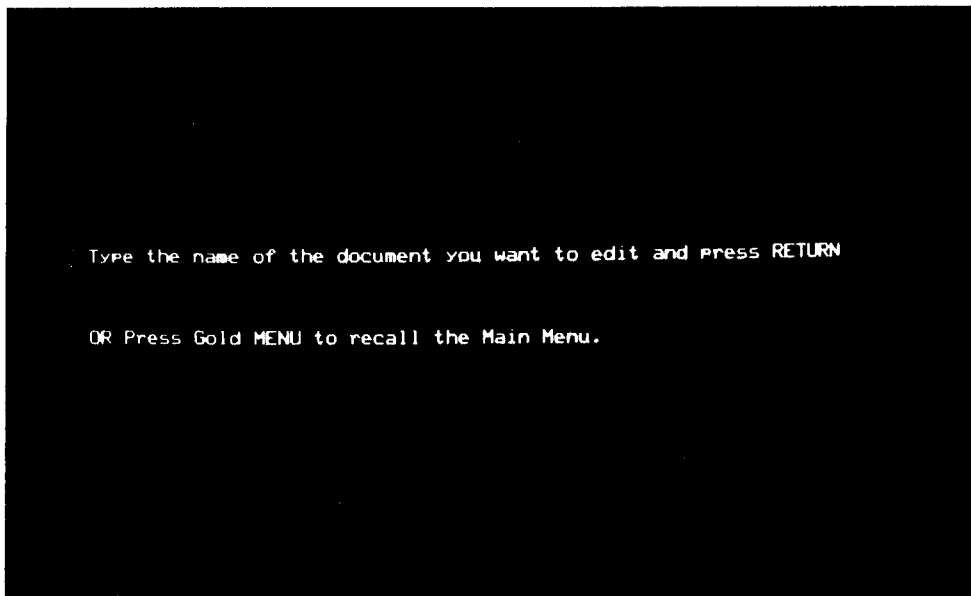

8920-22R1-A0078

Figure 5-1 Document Edit Prompt (1)

If you have previously worked on another document in the current word processing session, the system will ask you if you want to edit that document. If you have inspected the index, the system

will ask if you want to edit the document marked by the asterisk. For example, if you have just printed a document called "index" and you type the letter E, the screen display will look like this:

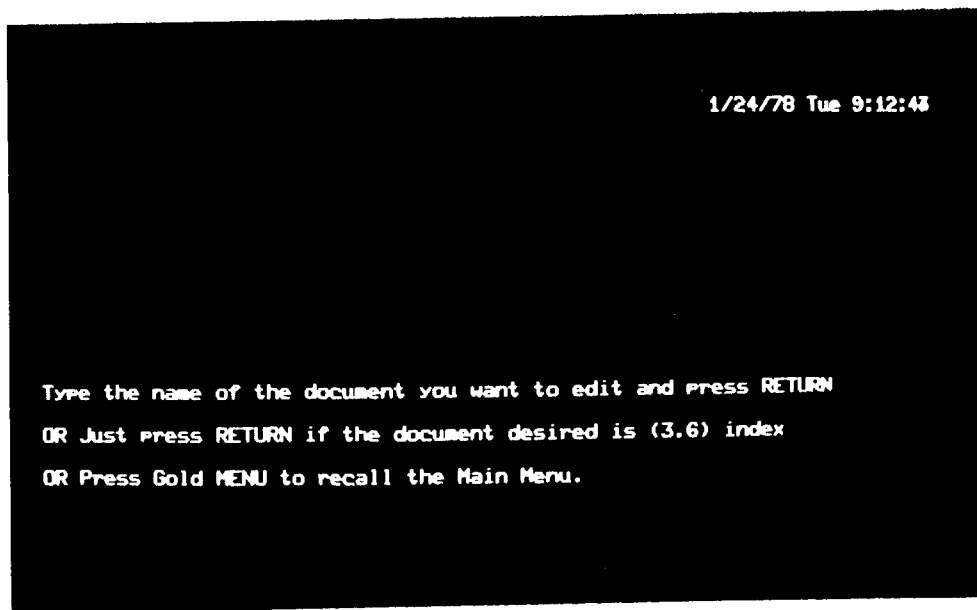

9113-29R1-A0079

Figure 5-2 Document Edit Prompt (2)

As a shortcut, you can type the letter E, a space, identify the document, and press the RETURN key. In this case the word processing system does not prompt for your document name because you've already typed it.

5.1.1 Identifying a Document To Be Edited

To identify the document you want brought to the screen, type its name and press the RETURN key. If you specify a document which

does not exist, the system will display an error message asking you to try again.

You may use either upper case, lower case, or a combination of the two. For example, if your document is called "Profit&Loss" you may type "profit&loss" or "PROFIT&LOSS" and the word processing system will automatically find the correct document.

If your document name is long but has at least one space, you can type just the first word. For example, if you want to use a document called

Kimball memo9/9/77

you may type just the following:

Kimball

Be certain to type a complete word. If you don't, the word processing system will display an error message on the screen asking you for another name.

You may also type the document's number in the index instead of its name. This is useful if your document names are long and you know their numbers. For example, suppose you want to use a document called "carburetor.specifications" and you don't care to type all those letters. Suppose also that you print an index daily (see Section 4.3). All you have to do is look for "carburetor.specifications" in the printed index and type its number.

5.1.1.1 Document Storage Location – You can bring a document from either the document or the system diskette to the screen. To specify that a document is stored on the document diskette, just type its name (or number). To specify that a document is stored on the system diskette, type the character { in front of the name (or number).

If you are operating a system that contains four diskette drives, you have two additional drives available for document storage. Appendix C.1 supplies details for how to specify documents stored in these systems.

5.1.1.2 Using the Index To Identify a Document – You can also use the index to identify a document, by doing the following:

1. **Type the letter I and press the RETURN key** when any Main Menu page is displayed on the screen. The first page of the index will be displayed on the screen. Notice an asterisk at the left of the first entry.

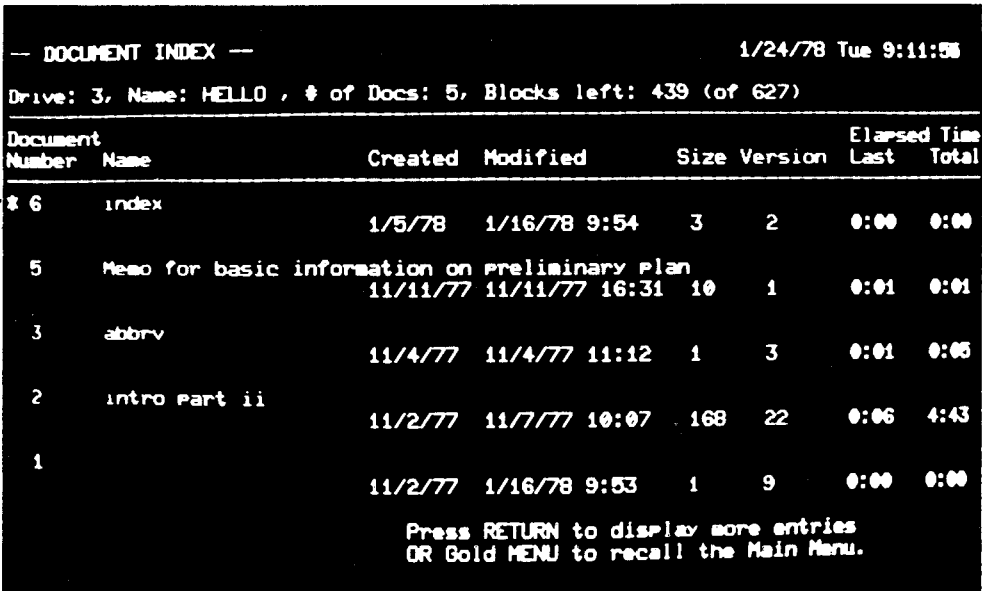

DOCUMENT INDEX		1/24/78 Tue 9:11:06					
Drive: 3, Name: HELLO, # of Docs: 5, Blocks left: 439 (of 627)							
Document Number	Name	Created	Modified	Size	Version	Elapsed Time	
						Last	Total
* 6	index	1/5/78	1/16/78 9:54	3	2	0:00	0:00
5	Memo for basic information on Preliminary Plan	11/11/77	11/11/77 16:31	10	1	0:01	0:01
3	abbrv	11/4/77	11/4/77 11:12	1	3	0:01	0:05
2	intro part ii	11/2/77	11/7/77 10:07	168	22	0:06	4:43
1		11/2/77	1/16/78 9:53	1	9	0:00	0:00

Press RETURN to display more entries
OR Gold MENU to recall the Main Menu.

① ASTERISK

9113-24R1-A0082

Figure 5-3 Using the Document Index to Indicate Document to Be Edited (1)

2. Press the ADVANCE key (mini keyboard, white) until the asterisk is in front of the document you want. For example, if you want to edit the document called "abbrv" press the ADVANCE key twice. Here is what the index will then look like.

Pressing the ADVANCE key when the asterisk is positioned in front of the last index entry on the screen causes the next index page to be displayed (provided there are more entries). Pressing the BACK UP key (mini keyboard, white) moves the asterisk

back to other index entries displayed on the screen. You cannot display a previous index page by pressing the BACK UP key.

3. Press the gold and the MENU keys. The Main Menu will be displayed on the screen again.

Now when you type the letter E and press the RETURN key, the word processing system will ask you if you want to edit the document you just marked (with the asterisk) in the index.

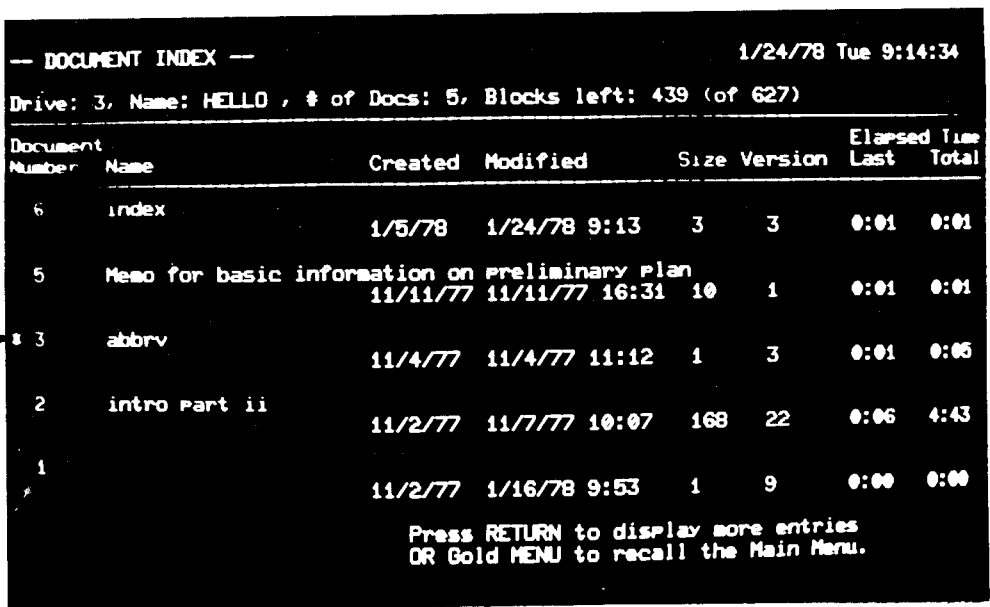

```

-- DOCUMENT INDEX --
1/24/78 Tue 9:14:34
Drive: 3, Name: HELLO , # of Docs: 5, Blocks left: 439 (of 627)
-----
Document Number  Name                Created      Modified      Size  Version  Elapsed Time Last  Total
-----
6      index                1/5/78      1/24/78 9:13   3      3        0:01  0:01
5      Memo for basic information on preliminary plan
      11/11/77 11/11/77 16:31  10      1        0:01  0:01
* 3      abbrv                11/4/77    11/4/77 11:12   1      3        0:01  0:05
2      intro Part ii       11/2/77    11/7/77 10:07   168    22       0:06  4:43
1
      11/2/77 1/16/78 9:53   1      9        0:00  0:00

Press RETURN to display more entries
OR Gold MENU to recall the Main Menu.

```

① ASTERISK

9113-33R1-A0081

Figure 5-4 Using the Document Index to Indicate Document to Be Edited (2)

5.1.2 Screen Display

Here is what the screen looks like when you bring an existing document to the screen for editing:

- ① **Diskette drive number and document number.** The first number is the diskette drive where the document is stored. The second is the document's number in the index.
- ② **Document name.** This is the name you specified after typing the letter C. If you specified one word of a longer name, only that word is displayed in this position. If you specified a document number, this position on the screen contains that number.
- ③ **Amount of storage space used.** This is the number of blocks (approximately 500 typed characters or one paragraph) which the document occupies on the diskette.
- ④ **Amount of storage space available.** This is the number of blocks still available for document storage on the diskette. If this number is less than 25 (preferably less than 50), you should either delete any obsolete documents or use another diskette.
- ⑤ **Number of text lines per page.** This is the maximum number of text lines that may appear on each page typed.

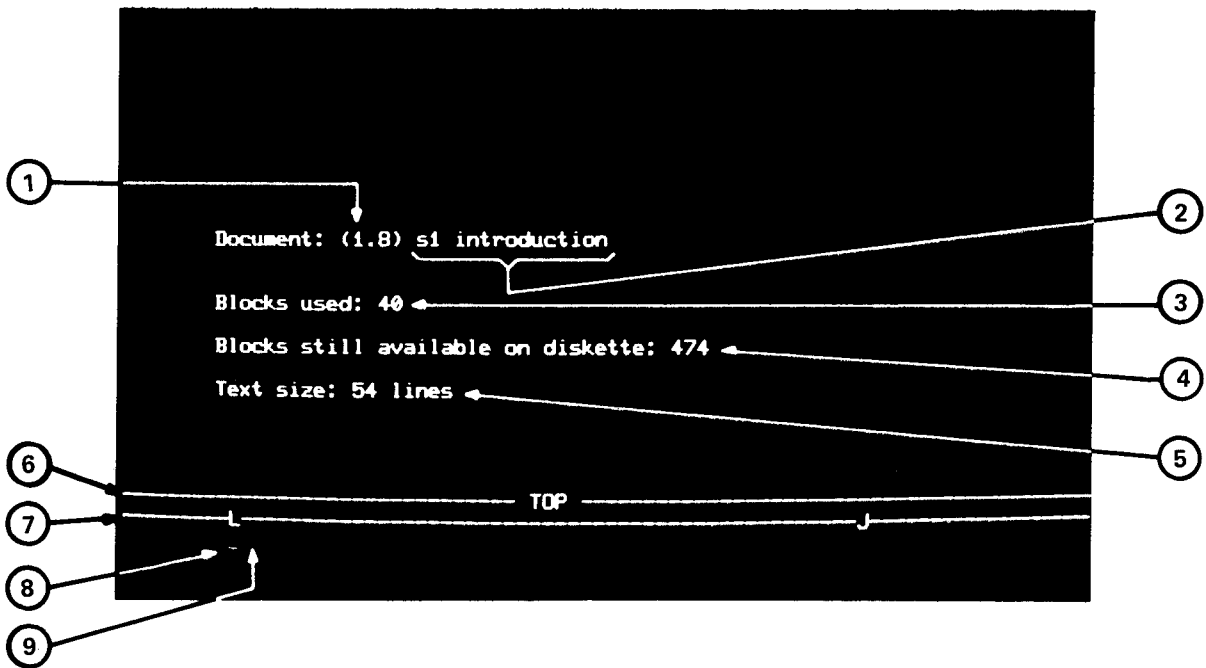

9113-35R1-A0080

Figure 5-5 Example of Screen Display When a Document Is Specified for Editing

- ⑥ **Top marker.** This marks the top of your text.
- ⑦ **Ruler.** These are the margin, tab, and vertical line spacing settings used at the beginning of your document.
- ⑧ **First line of text.** This is the first line that was typed when the document was created.
- ⑨ **Cursor.** This is a blinking underscore character which marks your current position in the document. Since you haven't yet edited anything, the cursor

is positioned at the beginning of the document.

5.1.3 Getting an Extra Version of an Existing Document

When you bring a document to the screen for editing and make changes to it, you no longer have a stored copy of your original document. Sometimes you may want to retain a copy of the original as an extra, or backup, version. This is useful if, for example, your boss makes pen and ink changes to a report but cautions you that the changes are not firm – just type them to see how they look before deciding to keep them.

To get an extra version of an existing document, follow these steps:

1. Create a new document.
2. Press the gold and the GET DOCMT keys. The system will ask for the name of the document to be copied.
3. Type the name (or number) of the document that you want to retain as the original. A complete copy of the original document will now be placed into the newly-created document.
4. File the document.

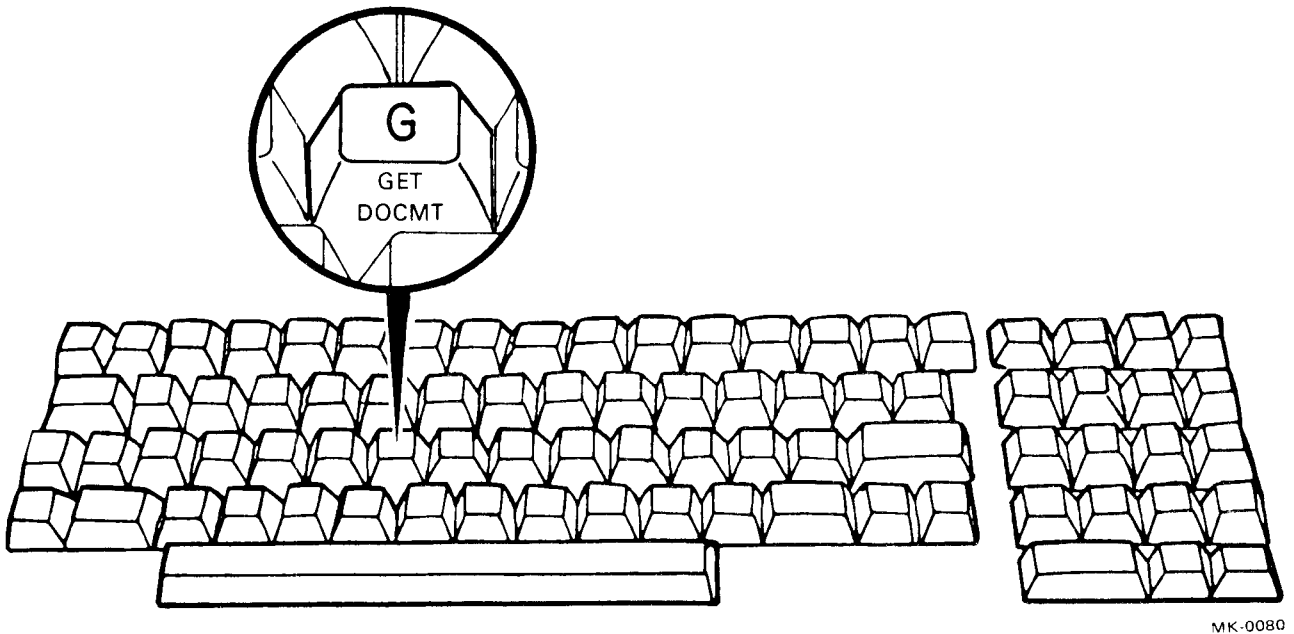

MK-0080

Figure 5-6 Main Keyboard GET DOCMT Key

5.2 MOVING THE CURSOR

In order to make changes, insert additional material, or examine a portion of your document not currently displayed on the screen, you must move the cursor to the desired location. You can move the cursor either forwards or backwards. There are three ways of moving the cursor through a document.

1. **With the mini keyboard grammatical keys**, to move over a particular word, line, sentence, tab position, paragraph, page, or > character (see Section 5.2.1).
2. **With the gold and the ADVANCE or BACK UP keys**, to move continuously through the text (see Section 5.2.2). This displays your

entire document on the screen as though it were a scroll. Hence, this technique is referred to as *scrolling*.

3. With the gold **TOP DOCMT** and **BOT DOCMT** key to move immediately to the top or bottom of the document (see Section 5.2.3).

You can also move the cursor to a particular word or group of words with a technique called *searching*. This is especially useful if you know exactly where you want the cursor to be located. For example, if your first change occurs under a section heading called "Survey Results" you can

search for "Survey Results" and have the cursor positioned there quickly. See Chapter 7 for details.

5.2.1 Using the Mini Keyboard Grammatical Keys

When you press the **ADVANCE** key located on the mini keyboard, the cursor moves forward one character, space, tab position, hard return, or word wrap return. If you press the **ADVANCE** key when the cursor is at the end of a line, it moves to the beginning of the next line. Similarly, when you press the mini keyboard **BACK UP** key, the cursor moves backward one position.

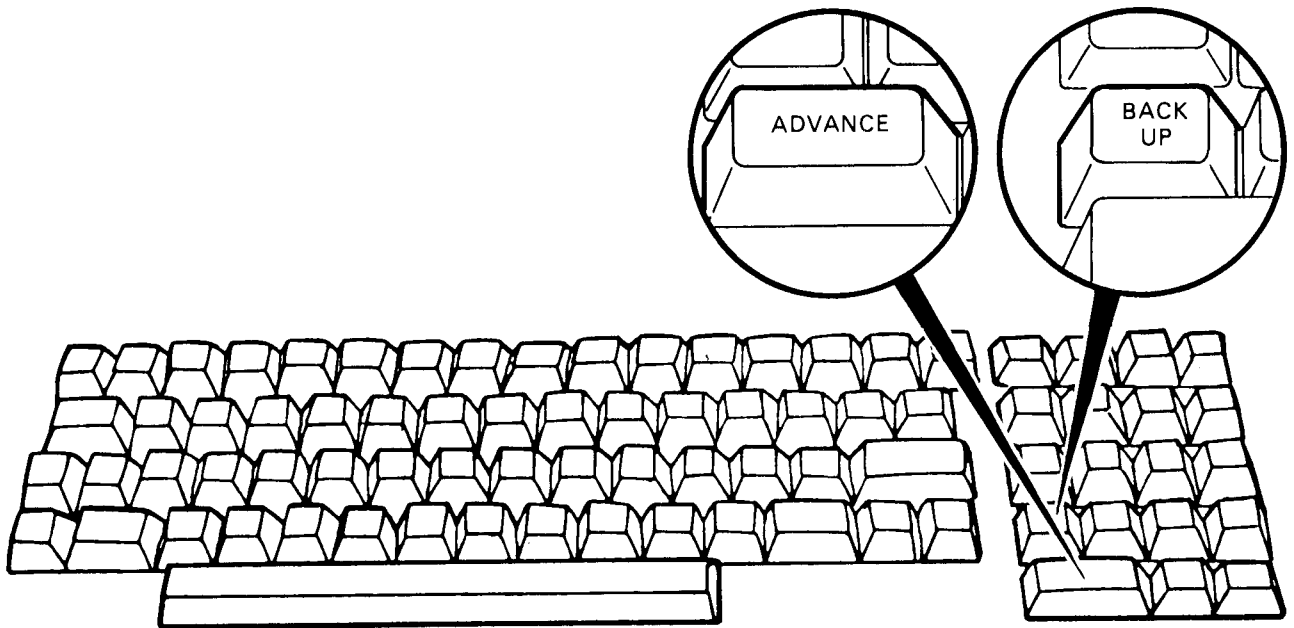

MK-0081

Figure 5-7 Mini Keyboard **ADVANCE** and **BACK UP** Keys

In addition, pressing either the **ADVANCE** or **BACK UP** key “sets” the direction of cursor movement. You can then use one of the blue grammatical keys to indicate how much text to move over.

Refer to Appendix A.2 for a description of each blue grammatical key.

You can also use the blue grammatical keys in the following ways:

1. **Repeating Movement.** You can move the cursor more than one grammatical item at a time by holding down the **REPEAT** key (main keyboard, bottom row) at the same time as either the **ADVANCE** key, **BACK UP** key, or one of the blue grammatical keys.
2. **Canceling Movement.** Once you press the **ADVANCE** or **BACK UP** key and one of the blue grammatical keys, you can stop the cursor from reaching its destination by pressing the gold and the **HALT** keys.
3. **Reaching the top or bottom of a document.** If you attempt to go forward when the cursor

is at the end of a document, the system will buzz and the cursor will not move. However, if you attempt to go backward when the cursor is at the top of a document, the system will buzz and the cursor will then move forward.

5.2.2 Using the ADVANCE and BACK UP Keys To Scroll

You can scroll, or move the cursor continuously through your entire document, by pressing the gold key before pressing either the **ADVANCE** or the **BACK UP** key.

If you do either of the following, the system will buzz.

1. Press the gold and **ADVANCE** keys when the cursor is located under the last typed position.
2. Press the gold and **BACK UP** keys when the cursor is located under the first typed position.

To stop scrolling, press the gold and the **HALT** keys.

5.2.3 Using The Gold TOP and BOT DOCMT Keys

You can move the cursor directly to the very first typed position in a document by pressing

the gold and the TOP DOCMT keys. You can move the cursor directly to the very last typed position by pressing the gold and the BOT DOCMT keys.

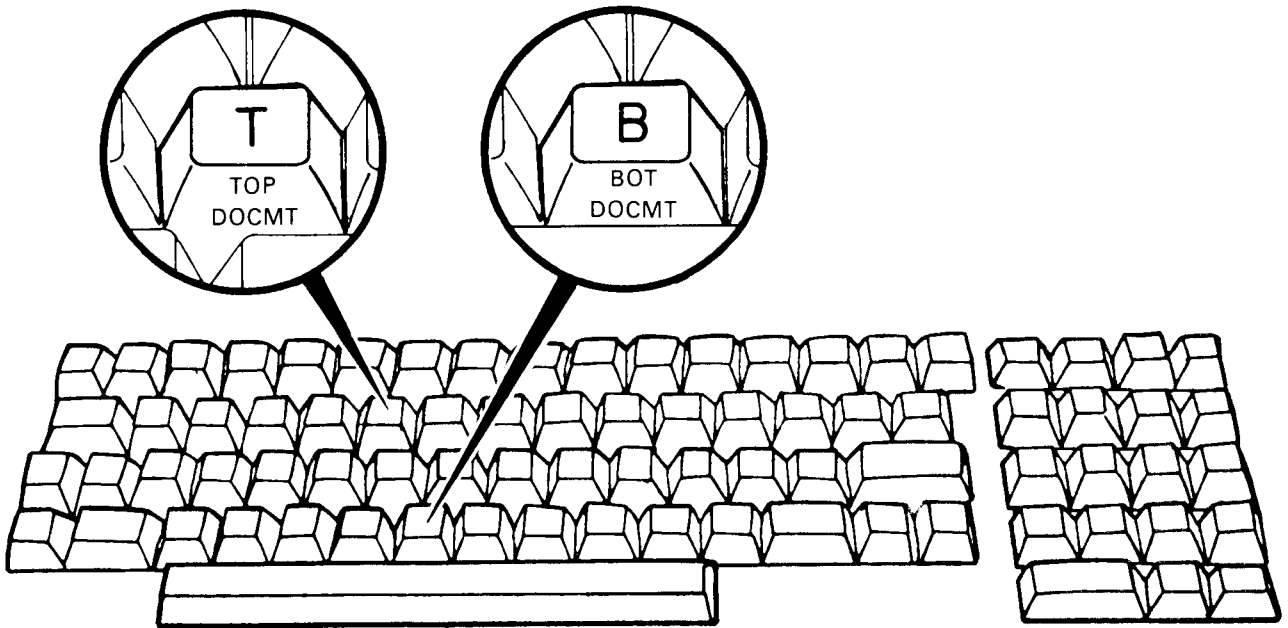

MK-0082

Figure 5-8 Main Keyboard TOP DOCMT and BOT DOCMT Keys

When you press the gold and the TOP DOCMT keys, the message

-- DOCUMENT FILING BEING COMPLETED --

is displayed on the screen. Then the top of your document is displayed with the cursor positioned under the first typed position. This method is equivalent to filing the document and bringing it to the screen to edit again.

Since you can move the cursor to the top of a document by pressing either the gold and BACK UP keys or the gold and TOP DOCMT keys, which method should you use? It all depends on how big your document is and where the cursor currently is located.

1. If the cursor is located near the beginning of your document, press the gold and BACK UP keys.

2. If your document is large and the cursor isn't located near the beginning, it's faster to press the gold and TOP DOCMT keys.

When you press the gold and the BOT DOCMT keys, the screen will momentarily go blank, the last 24 lines of your document (only 11 if your right margin is set beyond typing position 79) will be displayed on the screen, and the cursor will be located under the last typed position.

If you change your mind after pressing the gold and BOT DOCMT keys, you can cancel the effect by pressing the gold and the HALT keys. However, you cannot stop the system once you press the gold and the TOP DOCMT keys.

5.3 INSERTING ADDITIONAL TEXT

You can insert additional text into any document – one which you've just created or one which you've brought to the screen for editing.

To insert additional text, follow these steps:

1. **Position the cursor where the new text is to begin.** Use any of the cursor movement techniques described in Section 5.2.
2. **Type the additional text.** What you type is added to your document to the left of the cursor. As you type, the new text is displayed on the screen and the cursor moves forward.
3. **Word wrap the paragraph.** When you insert text, the line endings are "thrown off" so that succeeding lines extend beyond the right margin. To reformat the text, press the mini keyboard PARA key (it also advances the cursor forward to the next paragraph).

5.4 MAKING CHANGES

There are many different ways to change a document. They range from simply correcting a typo to picking up text and moving it to another location in the same (or even a different) document.

Here are four ways of making a change to a document (in addition to using the RUB OUT keys described in Section 3.2.2):

1. Interchange two characters by using the SWAP key located on the mini keyboard (see Section 5.4.1).
2. Delete characters or words by pressing the red DEL CHAR or DEL WORD key located on the mini keyboard (see Section 5.4.2).
3. Delete several words, lines, sentences or paragraphs by using the SEL and CUT keys located on the mini keyboard (see Section 5.4.3).
4. Move some text from one location to another by using the CUT and PASTE keys located on the mini keyboard (see Section 5.4.4).

You can also search for a particular phrase (word or group of words) and replace it with another phrase. Refer to Section 7.2 for details.

5.4.1 Interchanging Two Characters

If you accidentally reverse two characters, such as typing "teh" instead of "the," you can easily interchange them with the mini keyboard SWAP key. Just move the cursor so it's underneath the first character to be swapped and press the SWAP key. The two characters will be interchanged with the cursor positioned underneath the second.

5.4.2 Deleting a Character or Word

The red mini keyboard DEL CHAR key allows you to delete a single character, space, tab, hard return, PAGE MARKER, or NEW PAGE mark located above the cursor. The red mini

keyboard DEL WORD key allows you to delete a single word that begins where the cursor is located (including the character directly above the cursor).

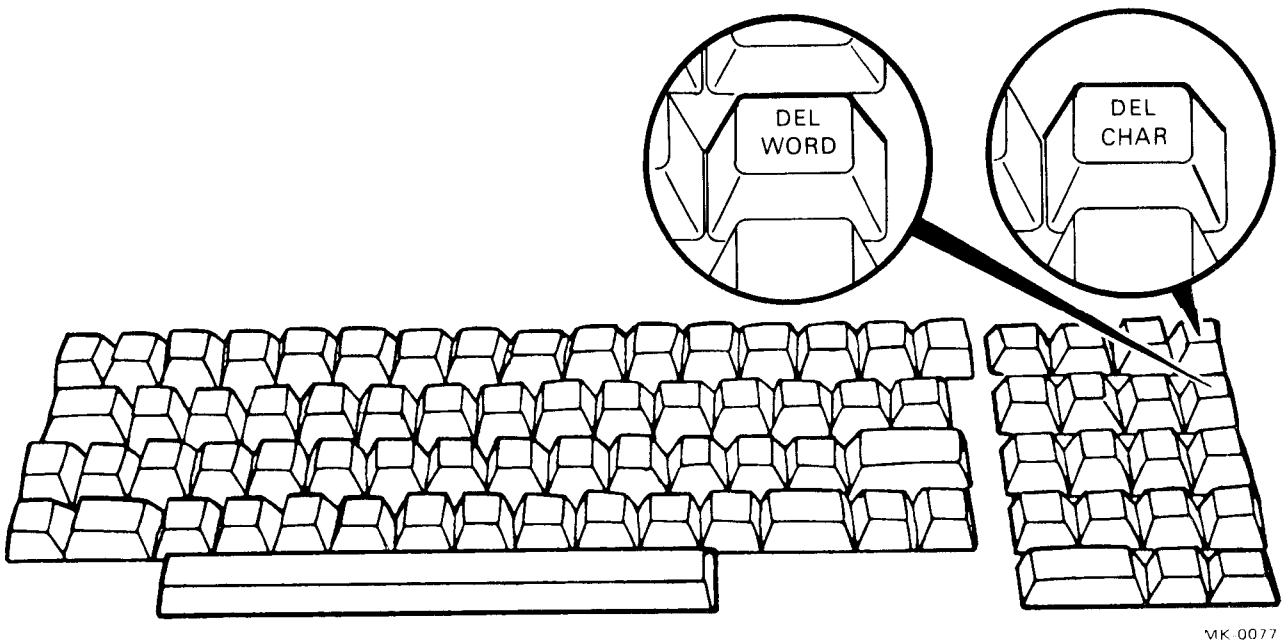

MK 0077

Figure 5-9 Mini Keyboard DEL WORD and DEL CHAR Keys

If you accidentally press the DEL CHAR or DEL WORD key, you can restore the deleted information by pressing the gold key and then either the DEL CHAR or DEL WORD key again.

While it is possible to remove more than one character or word, by holding down the REPEAT key (main keyboard) at the same time as the DEL CHAR or DEL WORD key, you might also delete more than you intended. Therefore, it is advisable to delete a larger portion of text by cutting.

5.4.3 Cutting: Deleting a Portion of Text

You can delete a group of words, lines, sentences, or paragraphs by using the SEL (for SE-lect) and CUT keys located on the mini keyboard.

To use these keys to delete a portion of text, follow these steps:

1. **Move the cursor to the beginning of the text and press the SEL key.** A select mark, or white square, will appear on the screen and the text will move down one line. If you accidentally press SEL in the wrong place, just press it again to remove the select mark.
2. **Move the cursor to right after the end of the text and press the CUT key.** All the text just

marked plus the white square is deleted. If you accidentally delete the wrong portion of text, you can restore it to your document. That's because the text just deleted was put in the system's paste area. Just press the PASTE key located on mini keyboard to restore the deleted text.

The maximum amount of text that can be cut at one time is 7500 characters, or approximately three pages. If you mark off more, only the first 7500 will be cut and the system will buzz (to warn you to return and cut the rest).

You can also press the SEL key at the end of the text to be deleted, move the cursor backwards, and then press the CUT key.

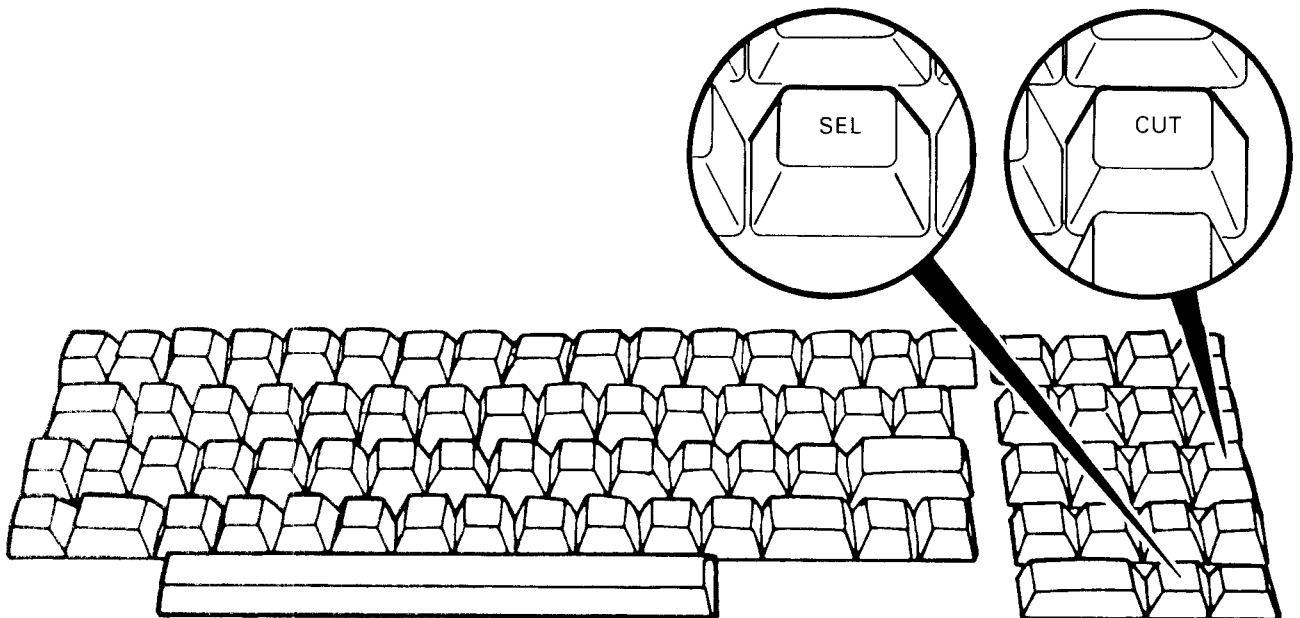

MK-0078

Figure 5-10 Mini Keyboard SEL and CUT Keys

5.4.4 Cutting and Pasting

You can remove a piece of text from a word processing document by *cutting* and then insert the same text elsewhere in your document by *pasting*. You can paste the same piece of text many times in many different places without ever having to retype it.

The CUT (red) and PASTE (black) mini keyboard keys are used for cutting and pasting.

To move text from one location to another by cutting and pasting, follow these steps:

1. **Put the text in the paste area by cutting it** (position the cursor at the beginning and press the SEL key, then position the cursor at the end and press the CUT key).

2. **Position the cursor** where you want to insert the text. This location may be in the same or an entirely different document (this latter requires you to file the document from which you have just cut and bring the document to receive the text to the screen for editing).

3. **Press the PASTE key.** The word processing system automatically inserts the text from the paste area and adjusts the rest of the text down to accommodate the addition. The inserted text is automatically adjusted to the ruler (margin and tab settings) in effect at the insertion point.

4. **Press the PARA key** (blue, mini keyboard) only if you have pasted into the middle of a

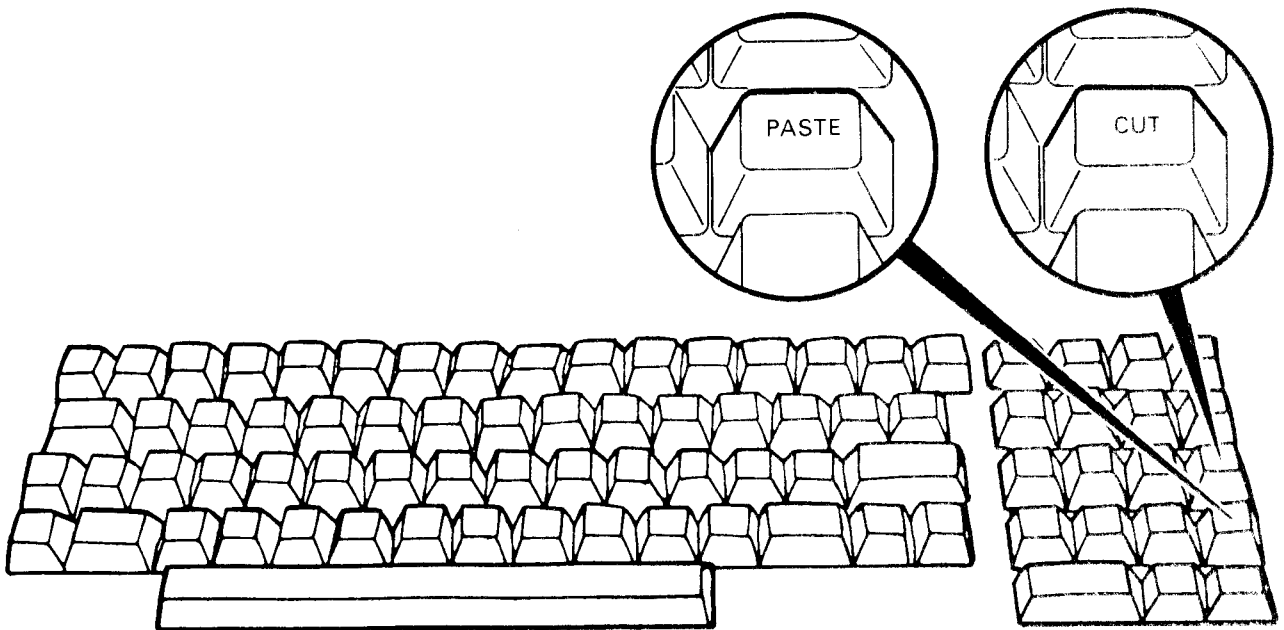

MF 0079

Figure 5-11 Mini Keyboard PASTE and CUT Keys

paragraph: line endings are "thrown off" so that the following text extends beyond the right margin. To reformat your text, press the PARA key. This action word wraps the remainder of the paragraph (advances the cursor forward to the next paragraph). If your pasted text is followed by a hard return, this step is not necessary.

Repeat steps 2-4 as many times as desired.

If you want to retain the text in its original location in addition to inserting it elsewhere, press the gold key BEFORE pressing the CUT key in step 1 above.

5.4.4.1 Preserving Rulers When Pasting – When a piece of text is cut and pasted, the margins and tabs (ruler) in effect in the new location are applied to the pasted text instead of the original ones.

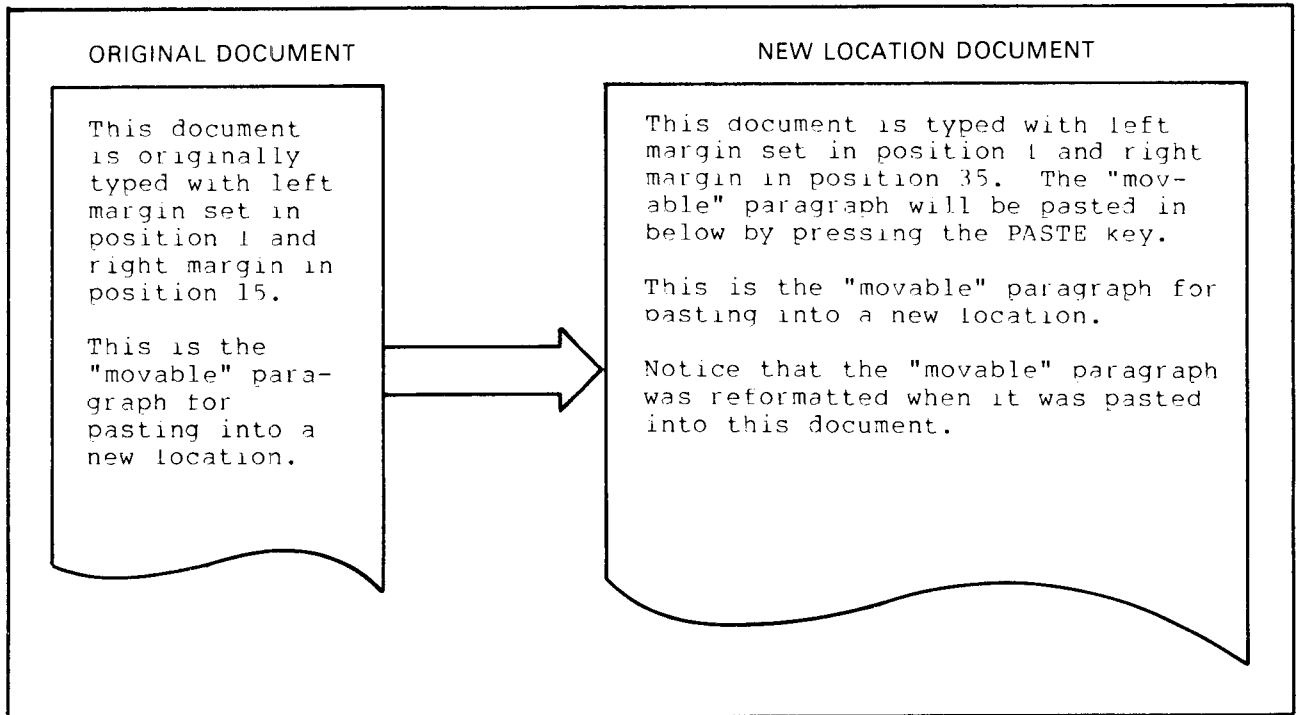

MK.0083

Figure 5-12 Example of Cutting and Pasting Using the Mini Keyboard CUT and PASTE Keys

In order to apply the ruler in effect in the original location to the pasted text, press the gold key BEFORE pressing the PASTE key. When cutting the text, use only the CUT key to put the text into the paste area. If you use the gold and the CUT keys, the original ruler will not be retained with the text when it is pasted.

In order to (1) cut and paste a piece of text keeping the original ruler and also (2) leave the text in its original location, then do the following:

1. Cut it from its original location by means of the SEL and CUT keys.
2. Immediately paste it right back by means of the PASTE key.
3. Paste it into the receiving location by means of the gold and PASTE keys.

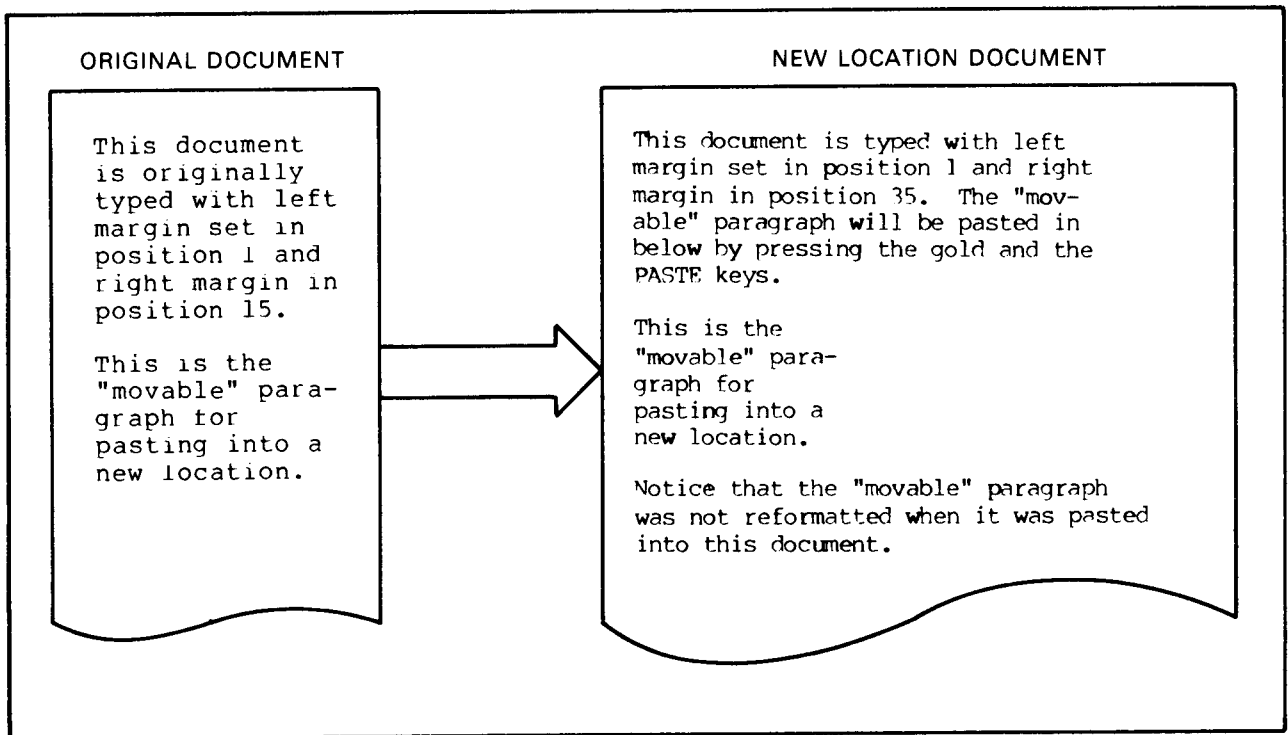

MK-0084

Figure 5-13 Example of Cutting and Pasting Using the CUT and Gold Plus PASTE Keys

5.4.4.2 Summary of Different Cutting and Pasting Key Combinations - The following table summarizes the ruler that is used as a result of pressing different combinations of the gold, CUT, and PASTE keys.

REMOVAL METHOD \ REPLACEMENT METHOD	PASTE KEY	GOLD AND PASTE KEYS
CUT KEY	NEW LOCATION RULER USED	ORIGINAL RULER USED
GOLD AND CUT KEYS	NEW LOCATION RULER USED	NEW LOCATION RULER USED

MK-0085

Figure 5-14 Ruler Used as a Result of Different Removal and Replacement Methods

CHAPTER 6 RULERS

Before you start typing on a typewriter, you generally set left and right margins in whatever positions you want and set vertical line spacing (single, double, space and a half, etc.) by moving a switch, button, or lever. You may also set up tabs for columns in a table or for text you want indented.

You work the same way with the word processing system except the procedure is easier. Instead of moving switches, buttons, levers, or knobs, you type a single character code in a particular

position in a ruler. A ruler contains your word processing left and right margin settings, vertical line spacing, and tabs (if any).

A ruler allows you to type text in one long stream without pressing the RETURN key. The system uses your right margin ruler settings to determine where to end each line and start the next. In addition, a ruler allows you to reformat text without having to retype: simply change the margin or tab settings in the ruler.

A ruler appears on the screen as a dashed line with characters in place of some of the dashes. Each dashed line corresponds to a typing posi-

tion (from 1 to 80) while each character corresponds to a particular kind of setting. Here is an example of two rulers:

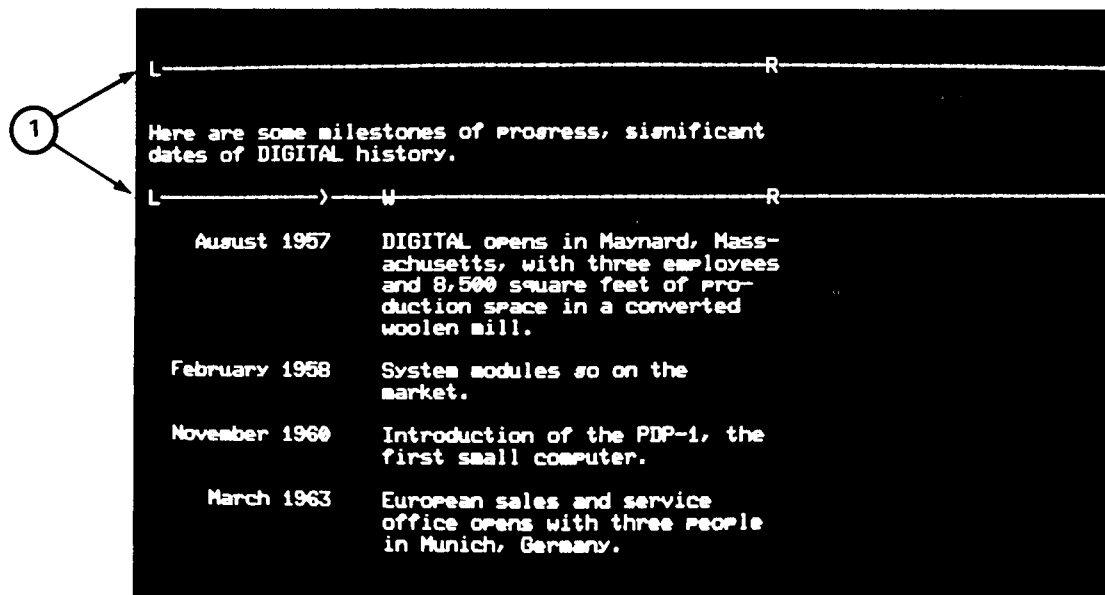

① RULER

9113-2R2-A0088

Figure 6-1 Example of Rulers

As you type or edit, the ruler may move off the top of the screen with your text. However, the word processing system will retain the ruler settings and continue using them to format your document.

6.1 USING A RULER

When you create a document, the word processing system automatically supplies a ruler that has preassigned settings (see Section 6.5 for how to change this "standard" ruler). If you are satisfied with the ruler, you can proceed with your

typing or editing. If you are not, change it. You may change a ruler anyplace in a document as many times as desired by doing the following:

1. Display the ruler (see Section 6.1.1).
2. Make all the desired ruler settings (see Section 6.1.2).
3. Clear the display and embed the ruler (see Section 6.1.3).

6.1.1 Displaying a Ruler

Displaying a ruler means the word processing system is ready to accept any new or changed settings you care to make. To display a ruler, press the gold and the RULER keys.

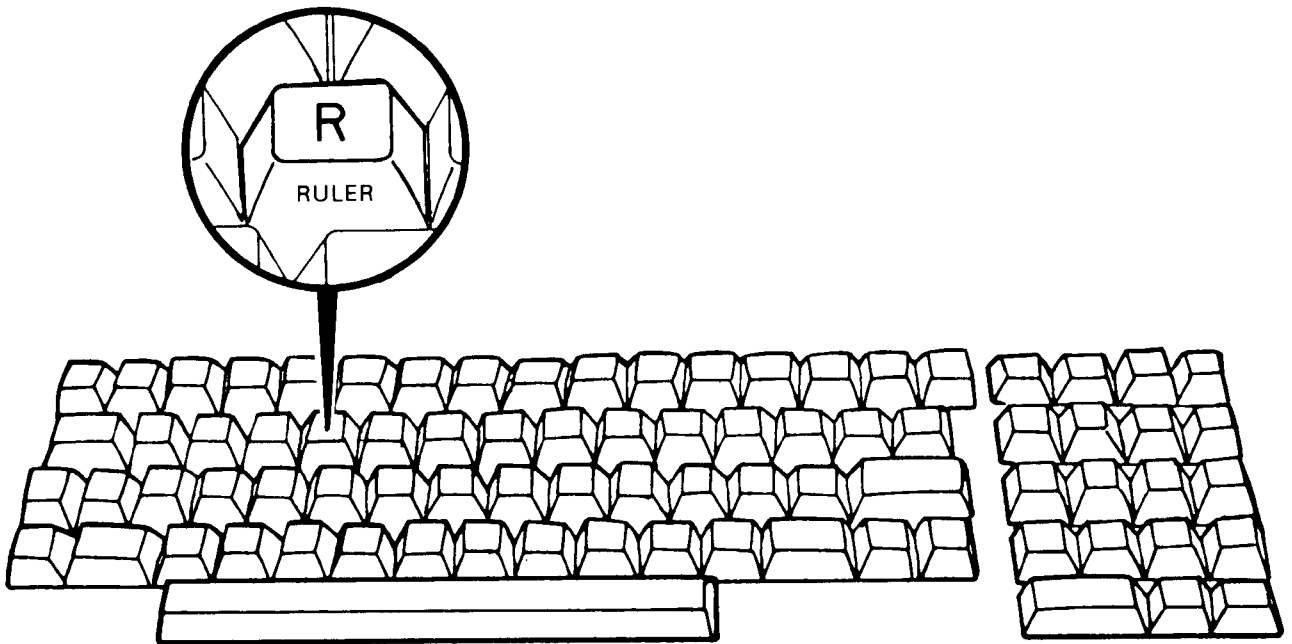

MK-0087

Figure 6-2 Main Keyboard RULER Key

A displayed ruler contains more detail than the dashes and characters ruler: every tenth position is marked with a single number (1, 2, 3, ... is used instead of 10, 20, 30, ...) and every fifth position with a dot.

You can display a ruler and make changes anywhere in a document. For best results, however, it is advisable to make changes only after a hard return (or at the beginning of the document).

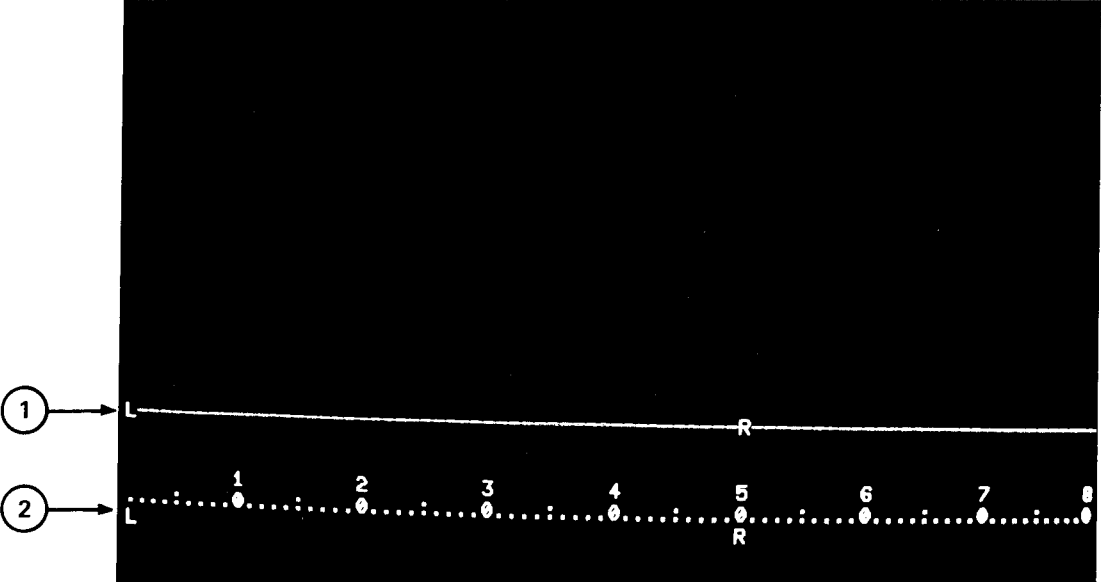

- ① RULER
- ② DISPLAYED RULER

9113-6R2-A0087

Figure 6-3 Example of Displayed Ruler

6.1.2 Making Ruler Settings

To make a ruler setting, display the ruler, move the cursor to the desired position, and type the character that corresponds to the setting you want.

When you display a ruler, the cursor is in the same position as it was in the text. You can move the cursor to any other position with the following mini keyboard keys:

Key	Action
ADVANCE	Moves the cursor forwards one typing position at a time. Pressing ADVANCE when the cursor is located in position 79 causes the ruler display to “split” in half and gives you a “wide” ruler, or 158 positions (see Section 6.3).
BACK UP	Moves the cursor backwards one typing position at a time. If you press BACK UP when the cursor is at ruler position 1, the terminal will buzz and the cursor will remain where it is.
WORD	Moves the cursor to the next ruler setting character. If you have previously pressed the BACK UP key, WORD moves the cursor backwards to the previous ruler setting.
LINE	Moves the cursor to position 80. If you have previously pressed the BACK UP key, LINE moves the cursor to position 1. When a wide ruler is in effect (see Section 6.3), pressing LINE when the cursor is located beyond position 80 moves the cursor to and from positions 81 and 158.

You can also hold down the REPEAT (main keyboard, bottom right) key with ADVANCE, BACK UP, or WORD to speed up the cursor’s movement.

Once the cursor is in the correct position, you can remove the current setting character by pressing the space bar or you can type a new one.

The following actions occur when you type a ruler setting:

1. The character you just typed appears above the cursor. This new character replaces any character previously there. Therefore, it isn’t necessary to delete a character before replacing it.
2. The cursor remains in the same position and is ready to move in the direction it previously was moving.

If you change your mind after making ruler settings, you can retrieve your original settings by pressing the = key (main keyboard, upper right). You can do this only while your ruler is displayed. (Once you clear the ruler display, your changed settings take effect.)

The different kinds of allowable ruler settings are:

Character	Description
F L N D	Left margin plus vertical spacing (see Section 6.1.2.1)
R J	Right margin (see Section 6.1.2.2)
P	Indent for the first word of a paragraph (see Section 6.1.2.3)

Character	Description
W	Automatic, or word wrap, indent for several lines of continuous text (see Section 6.1.2.4)
T >	Tab stops (see Section 6.1.2.5)
C	Centering point (see Section 8.1)
H	Hyphenation zone (see Section 11.5)

Appendix E contains a complete summary of all ruler setting characters.

6.1.2.1 Left Margin and Vertical Line Spacing – Both the position of the left margin and the amount of vertical line spacing are controlled by

typing a single character. There are four characters, or four kinds of vertical line spacing, to use.

Left Margin	
Character	Spacing Produced
F	Half-line
L	Single
N	Space and one half
D	Double

Text is always displayed on the screen single spaced. The F, L, N, and D characters take effect when a document is printed (it is also possible to add extra vertical space when printing a document without changing its rulers – see Section 13.3.6 for details).

Here is how some text typed with the four different left margin ruler settings appears on the screen:

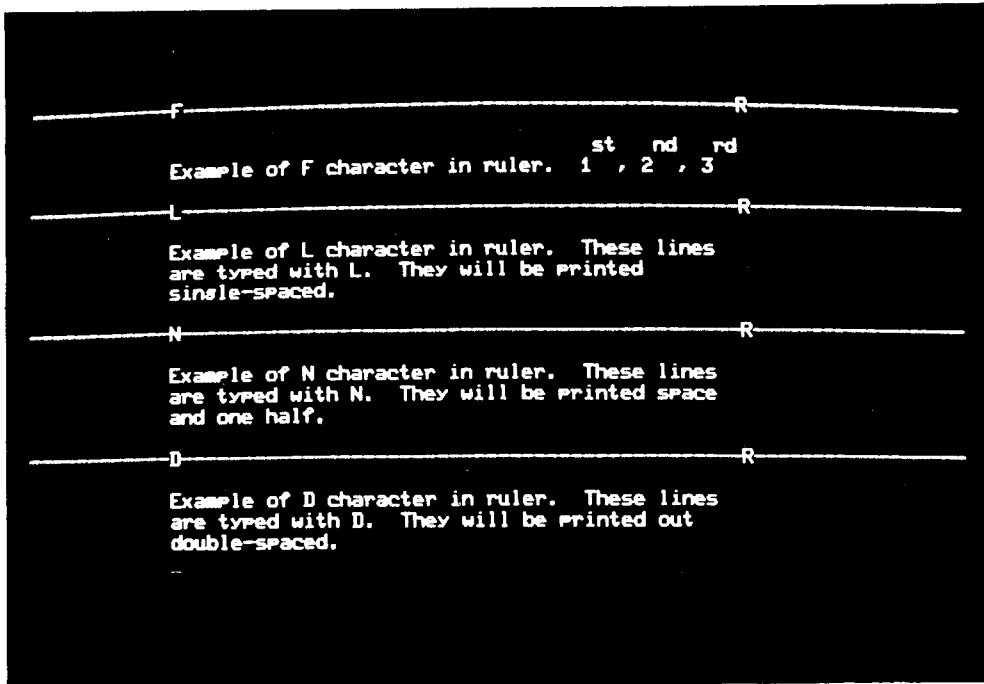

M123-5-A0192

Figure 6-4 Example of Different Left Margin Ruler Settings

Here is how the same text looks when it is printed:

Example of F character in ruler. 1st, 2nd, 3rd

Example of L character in ruler. These lines are typed with L. They will be printed single-spaced.

Example of N character in ruler. These lines are typed with N. They will be printed space and one half.

Example of D character in ruler. These lines are typed with D. They will be printed out double-spaced.

You must put one (and only one) of the left margin characters in a ruler.

6.1.2.2 Right Margin – The right margin setting in a ruler marks the last position on a line where a character may appear. There are two kinds of right margin ruler settings: ragged (R) and justified (J). Whether you use J or R in your ruler does not affect what word appears at the end of a line. It affects only how the line is spaced after the last word of each is determined.

Character	Meaning
R	Ragged right margin. All word wrapped lines are printed exactly as they appear on the screen. Lines with ragged right margins look the same as those produced on an ordinary typewriter, just as these lines do.

Character**Meaning**

J

Justified right margin. All word wrapped lines are lined up uniformly on the right when printed, like the lines you're now reading. However, justified lines are displayed on the screen the same as ragged lines.

Justification is performed differently on the two types of word processing printers. If a letter quality printer is used, lines are justified by adding space in 1/120 inch units between both characters and words. If a draft printer is used, lines are justified by adding space in 1/10 inch units only between words.

You must put one (and only one) of the right margin characters in a ruler.

6.1.2.3 Paragraph Indent – The P ruler setting character allows you to type indented paragraphs. These are indented from the regular left margin and are separated from the previous paragraph by a single carriage return.

To indent a paragraph, follow these steps:

1. **Put the letter P in your ruler** at the typing position where you want the paragraph to start. You can have only one P setting in a ruler. If you type a second one, the system will automatically remove the first.
2. **Press the gold and the PARA MARKER keys** at the beginning of each paragraph.

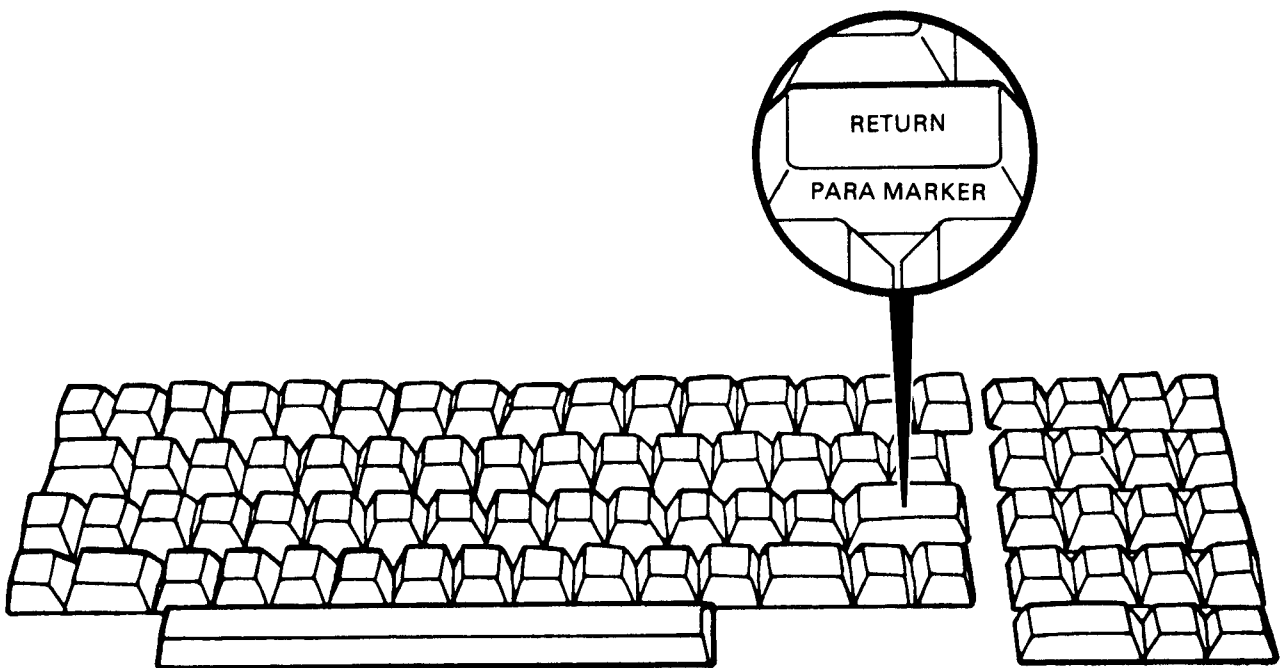

MK-0088

Figure 6-5 Main Keyboard PARA MARKER Key

Pressing the PARA MARKER key inserts a paragraph mark into your document. While this mark is not displayed on the screen (except when you view text), it nevertheless occupies one typing position. Therefore, you can remove it from your text with either the DEL CHAR or RUB CHAR OUT key.

It is not readily obvious (either in the screen display or in the printed document) whether in-

dentented text was spaced in, tabbed, or typed with a paragraph indent. To determine how the paragraph was typed, you must view it by pressing the gold and the VIEW keys (see Appendix D). When viewed, a paragraph mark is displayed on the screen as a ¶.

Here is an example of viewing a paragraph indented by means of ruler setting character P and the PARA MARKER key:

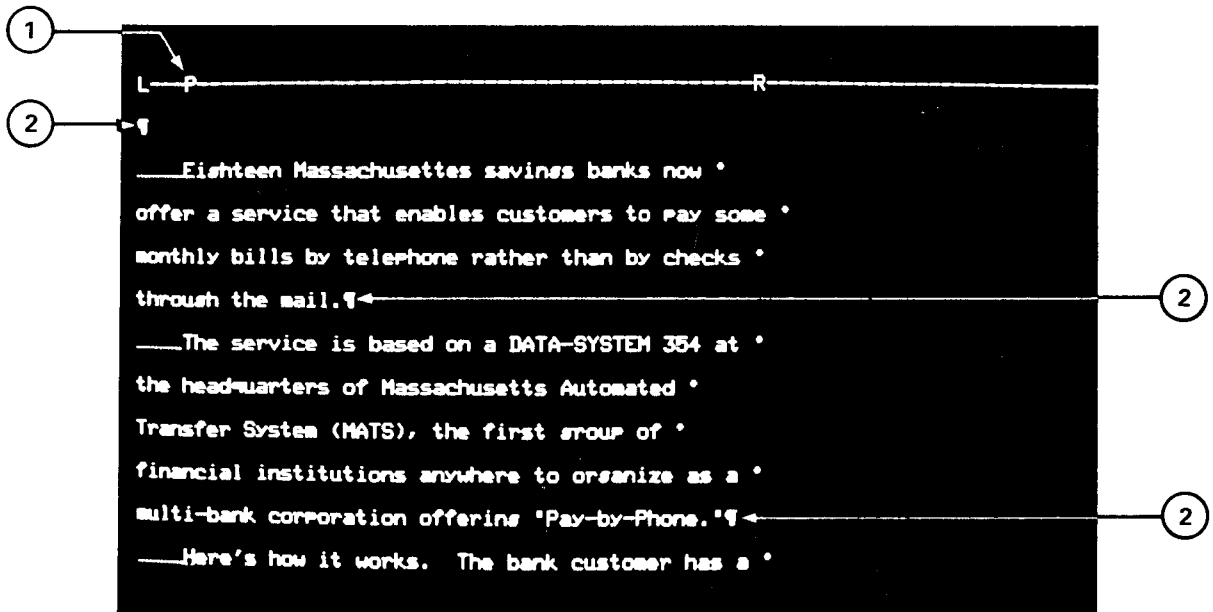

- ① LETTER P IN RULER
- ② PARAGRAPH MARKS IN TEXT

9113-10R2-A0092

Figure 6-6 Example of Paragraph Indent

If you always indent paragraphs (instead of separating them with two hard returns), you should use ruler setting P. This allows you to use the mini keyboard PARA key to move from one paragraph to another when editing. While you could also produce indented paragraphs by tabbing (or typing spaces), this method does not allow you to edit with the PARA key.

6.1.2.4 Automatic Word Wrap Indent – The W ruler setting character allows you to specify a position for automatic indenting. All lines after the first will automatically be indented by the word processing system. These lines are an example of word wrap indent. In order to indent the first line, press the TAB key.

Here is an example of how automatically indented text is displayed on the screen:

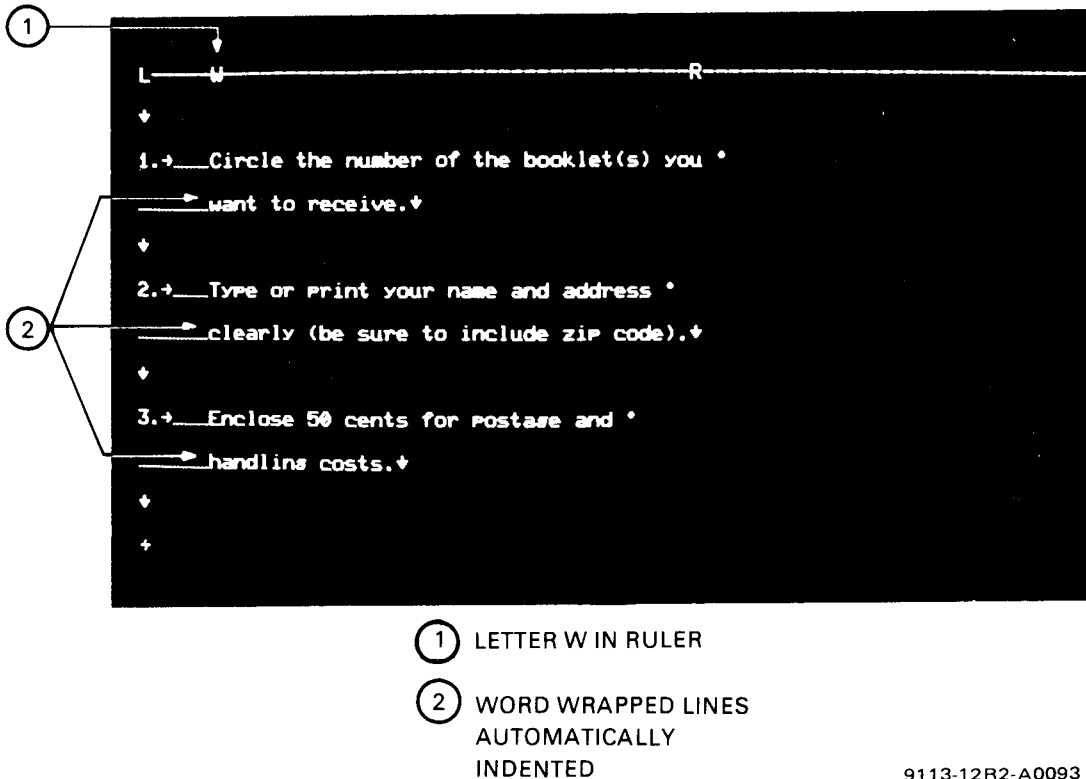

9113-12R2-A0093

Figure 6-7 Example of Word Wrap Indent

You can have only one W setting in a ruler. If you type a second, the system will automatically remove the first.

6.1.2.5 Tabs – Tabs allow you to advance immediately from one position on a line to another by pressing the TAB key just once (instead of typing several spaces).

To produce tabbed text, follow these steps:

1. Put a tab setting character in your ruler to mark the location of each tab.
2. Press the TAB key (blue, upper left of main keyboard) before typing each word to be tabbed.
3. Press the RETURN key after the last tabbed entry on each line.

The following is a summary of the ruler setting characters for tabbed text.

Character	Meaning
T	Left-justified tab. Tabbed text is lined up on the leftmost character.
>	Right-justified tab. Tabbed text is lined up on the rightmost character.
.	Decimal-aligned tab. Tabbed text is lined up on a decimal point. If no decimal point is present, the tabbed text is lined up on rightmost hard return or tab. The text may start with a dollar sign (\$), plus (+), minus (-), or any other characters followed by a space.

Here is an example of using these three ruler setting characters:

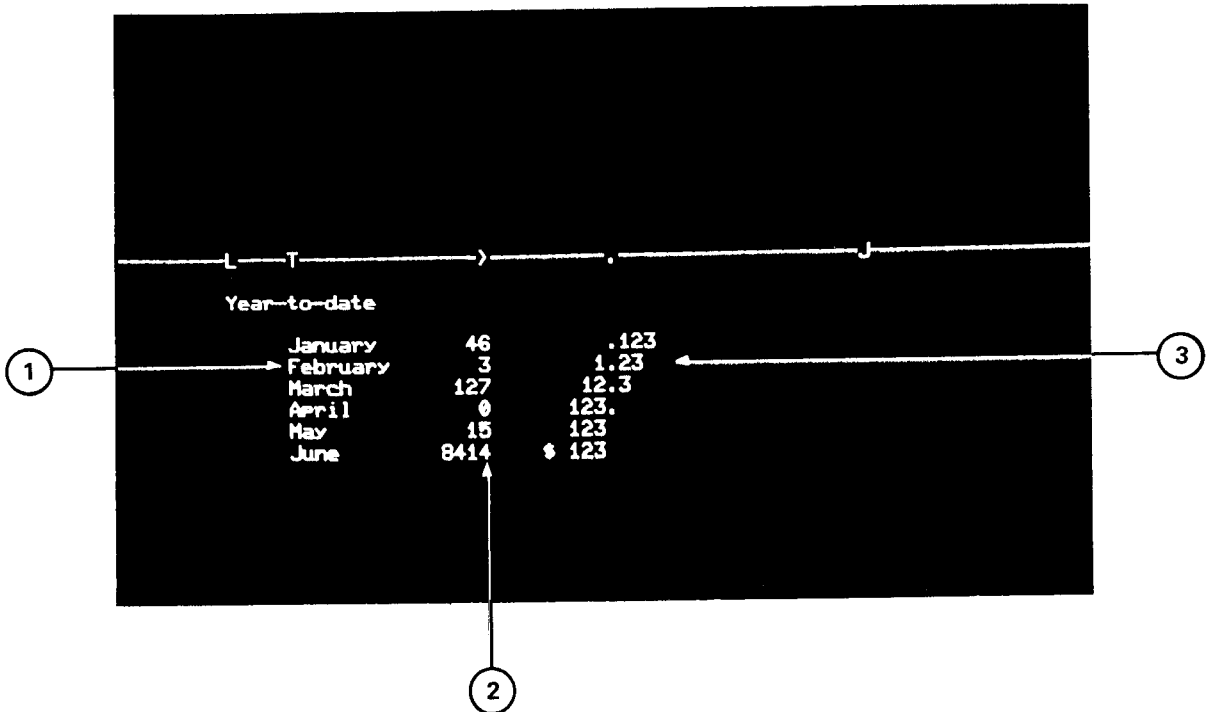

- ① LEFT-JUSTIFIED TABBED TEXT
- ② RIGHT-JUSTIFIED TABBED TEXT
- ③ DECIMAL-ALIGNED TABBED TEXT

9113-14R2-A0090

Figure 6-8 Example of Left-Justified, Right-Justified, and Decimal-Aligned Tabs

You can also use a paragraph indent (ruler setting character P) or an automatic word wrap indent (ruler setting character W) as a left-justified

tab and the right margin (ruler setting character R or J) as a right-justified tab. Here is an example of using the right margin as a tab:

The diagram shows a ruler with three characters: 'L' at the left end, 'W' at a middle position, and 'R' at the right end. Below the ruler is a table of contents. The table has four rows of items. The first row is 'Chapter 1 INTRODUCTION'. The next four rows are numbered 1.1 through 1.4. The page numbers are 1-1, 1-5, 1-9, and 1-10. A right curly bracket groups the four numbered rows. An arrow points from a circled '1' to the right margin of the table, indicating that the right margin is used as a tab for these items.

Table of Contents		
Chapter 1	INTRODUCTION	
1.1	Review of the Project	1-1
1.2	Summary of Results	1-5
1.3	Intended Audience	1-9
1.4	How To Use This Report	1-10

① TEXT TABBED AT RIGHT MARGIN

9113-16R2-A0089

Figure 6-9 Example of Using the Right Margin as a Tab

It is not readily obvious (either in the screen display or in the printed document) whether text has been positioned by tabbing or by typing spaces. To determine how the text was typed, you must view it by pressing the gold and the VIEW keys (see Appendix D for complete details). When viewed, spaces are displayed on the screen as blanks while tab marks are displayed as follows:

1. A → character at the typing position where the TAB key is pressed.
2. A series of dots for each typing position up to the next tab mark.

Here is an example of how text produced by both tabbing and spacing looks when viewed:

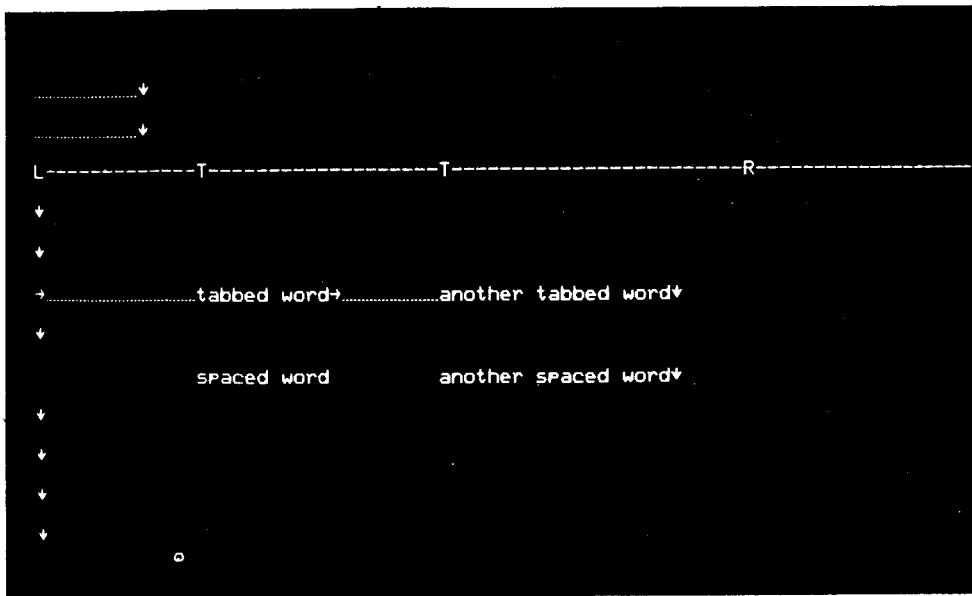

8920-12R2-A0083

Figure 6-10 Example of Viewing Tabbed Text

Pressing the TAB key inserts a tab mark into your document. While this mark is not displayed on the screen (except when you view text), it nevertheless occupies one typing position. Therefore, you can remove it from your text with

either the DEL CHAR or RUB CHAR OUT key. This action removes both the tab mark and ALL of the spaces that follow it (you cannot remove tabbed spaces individually as you can with spaces produced with the space bar).

6.1.2.6 Incorrect Settings – The word processing system does not allow you to type incorrect ruler setting characters. Here is what happens if you try.

1. **You type a character which cannot be used in a ruler.** The system will buzz and not display that character.
2. **You type a second left or right margin, paragraph indent, or automatic word wrap indent setting.** The system will automatically remove the previous setting.
3. **You type too many settings.** The maximum number of settings allowable in an 80-character ruler is 20; in a wide ruler, 40. If you exceed these limits, the system will not let you clear the ruler display. When you try, the system will buzz (to warn you of the error condition) and the cursor will be positioned under the first setting that exceeds the limit.

6.1.3 Clearing a Ruler Display

When you are satisfied with a ruler, clear the display by pressing the RETURN key. Clearing the display produces these results:

1. The ruler will be *embedded* in your document. If you changed or added at least one setting, you'll now see your new settings in the dashes and characters type of ruler (the old ruler no longer appears). Embedding means the word processing system will use the new ruler settings on all succeeding text. These settings will be in effect until the next ruler change.
2. You can now type and change text.

To clear a displayed ruler without saving the settings just typed, press the gold and the RULER keys.

When you embed a ruler in a document, line endings may possibly be “thrown off” so that succeeding lines extend beyond the right margin. To reformat, or word wrap the text, press the mini keyboard PARA key until the cursor comes to the next ruler (or end of document).

6.2 CHANGING RULERS IN TYPED TEXT

If you don't like the format of your typed text, you can reformat it without doing any retyping. Just change your ruler settings. The system will automatically readjust your text to fit the new settings.

For example, you can convert an entire document typed with margins at 1 and 65 to a narrower one, with margins at 1 and 50, just by changing a ruler. Similarly, you can change the column placement in a table by changing its ruler. Suppose, for example, you set up tabs and type the following lines.

Employee	Telephone
Davis	223-3167
London	457-9920

When you go to type a line for the next employee, named Cunningham, you discover you did not set your tabs to leave enough space between columns. All you have to do to correct this situation is place the cursor at the top of the table and move the tab setting to the right. The system will automatically adjust the placement of telephone numbers for Davis and London.

6.3 USING A WIDE RULER

If you type charts, summaries, or tables with many columns, you may need more than 79 typing positions per line. You can have as many as 158 typing positions per line with a wide ruler.

To use a wide ruler, press the gold and the RULER keys and advance the cursor beyond position 79. Ruler positions 1-80 will be displayed at the bottom of the screen; ruler positions 81-158, at the top.

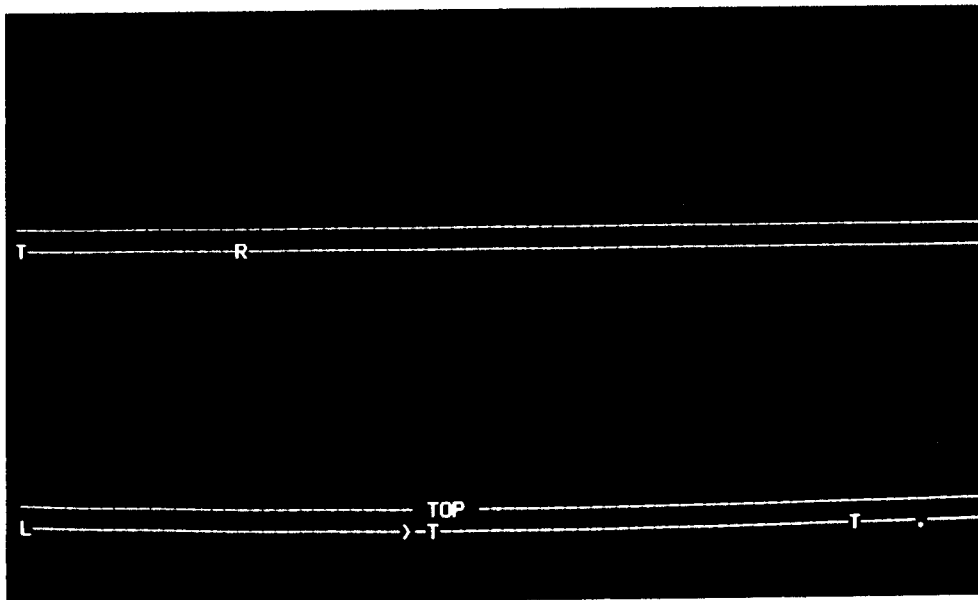

9113-18R2-A0094

Figure 6-11 Example of Wide Ruler

By setting your right margin in any position between 80 and 158, all text that follows the ruler will be stored and printed out as “wide lines” (it is not possible to make any settings in positions 159 and 160).

Because a single line of the screen can display only 80 positions, a wide text line is split in two.

The first half of each wide line is displayed at the bottom of the screen and the second half at the top. At most, 11 full lines are displayed on the screen at one time. The right half of the 11 lines is displayed at the top, the left half at the bottom. They are separated by two blank lines.

Here is how some text appears on the screen when a wide ruler is in effect:

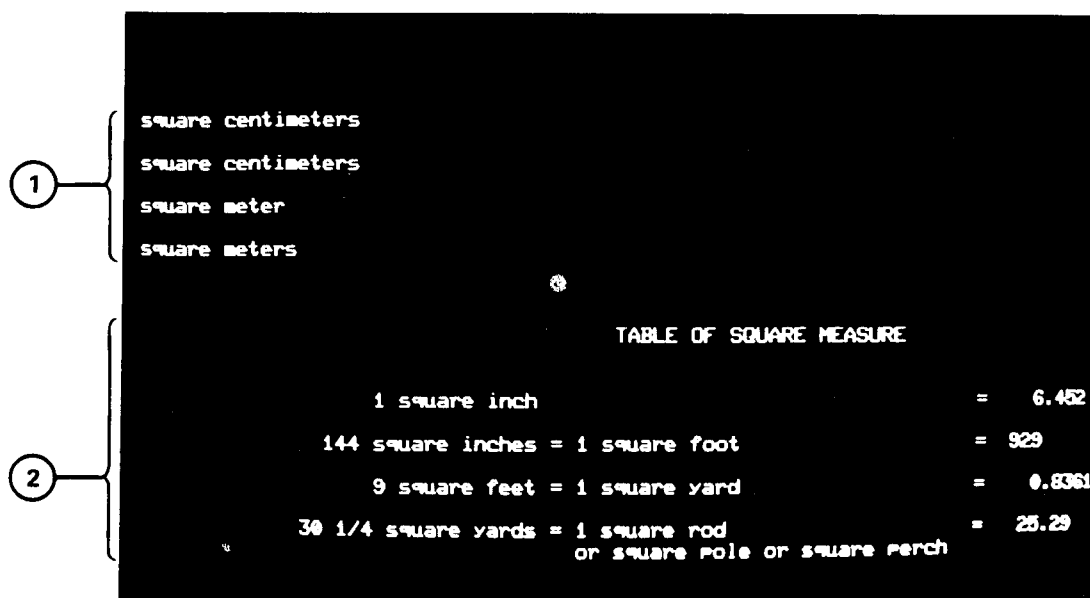

① CHARACTERS 81 TO 158 OF EACH LINE

② FIRST 80 CHARACTERS OF EACH LINE

9113-20R2-A0091

Figure 6-12 Displayed Example of Text Typed with Wide Ruler in Effect

The following page shows how the same text looks when printed.

You need special, wide paper to print a document typed with a wide ruler. For this reason, it is advisable to place wide line text in a separate document.

TABLE OF SQUARE MEASURE

1 square inch	=	6.452	square centimeters
144 square inches = 1 square foot	=	929	square centimeters
9 square feet = 1 square yard	=	0.8361	square meter
30 1/4 square yards = 1 square rod or square pole or square perch	=	25.29	square meters
160 square rods or 4,840 square yards or 43,560 square feet = 1 acre	=	0.4047	hectare
640 acres = 1 square mile	=	259	hectares or square kilometers
		2.59	

MK-0086

Figure 6-13 Printed Example of Text Typed
with Wide Ruler in Effect

6.4 SAVING RULERS FOR REUSE

You can save all the settings in a particular ruler to use again (with either the same or a different document). You may save as many as ten different rulers.

To save a ruler, follow these steps:

1. Display the ruler and make any desired settings.
2. **Hold down** the SHIFT key and type a single number between 0 and 9. The settings saved with ruler number 0 are what you automatically get when you create a document. Therefore, type the number 0 only when you want to use the particular ruler settings with every document you create.
3. Clear the ruler display.

To retrieve a ruler you must use the same system diskette with which you saved the rulers (because they are stored on the system diskette). Follow these steps:

1. **Press the gold and the RULER keys** to display the ruler.
2. **Type the ruler's number.** The settings which you previously saved will automatically be displayed on the screen.
3. **Clear the ruler display.**

You can examine all stored rulers by typing the numbers 0 through 9 while a ruler is displayed. Each corresponding ruler will be displayed on the screen.

6.5 CHANGING AN UNDESIRED RULER

When you edit portions of text, you may sometimes be left with an undesired ruler. For example, suppose you have text that looks like this:

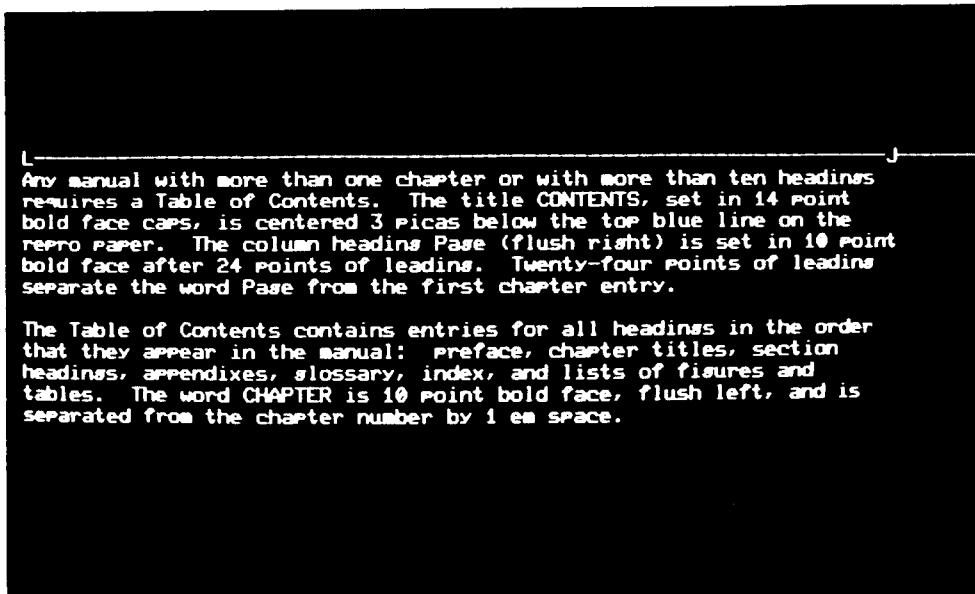

9113-22R2-A0084

Figure 6-14 Example of Text Before Pasting

If you should add a new paragraph with a different ruler between the first and second paragraphs, the new ruler will cause the second and succeeding paragraphs to be reformatted.

Any manual with more than one chapter or with more than ten headings requires a Table of Contents. The title CONTENTS, set in 14 point bold face caps, is centered 3 picas below the top blue line on the repro paper. The column heading Page (flush right) is set in 10 point bold face after 24 points of leading. Twenty-four points of leading separate the word Page from the first chapter entry.

NOTE

1 → Leading is defined as the total distance measured from baseline to baseline; it is not just the white space appearing between the lines of text.

2 → The Table of Contents contains entries for all headings in the order that they appear in the manual: preface, chapter titles, section headings, appendixes, glossary, index, and lists of figures and tables. The word CHAPTER is 10 point bold face, flush left, and is separated from the chapter number by 1 em space.

9113-24R2-A0085

- 1 PARAGRAPH INSERTED WITH NEW RULER.
- 2 PARAGRAPH REFORMATTED BECAUSE OF INSERTED PARAGRAPH.

Figure 6-15 Reformatted Example of Text After Pasting

To achieve the desired results in this example, you must replace the undesired ruler at the beginning of ② .

To restore a correct ruler, follow these steps:

1. Position the cursor in text that contains the desired ruler and then:
 - Display the ruler.
 - Store the ruler with a number you are not using for other text (generally, you

should reserve one ruler number especially for this purpose).

- Clear the ruler display.
2. Position the cursor where the ruler is to be changed and then:
 - Display the ruler.
 - Retrieve the ruler stored in step 1.
 - Clear the ruler display.

CHAPTER 7 SEARCHING

If there is a particular phrase (group of characters or words) in your document that you want to inspect or edit, you can quickly move the cursor there by searching. For example, suppose you want to add some new material to a section of your document that begins with “Executive Summary.” Just tell the word processing system to search for these two words. The system will automatically display the line containing “Executive Summary” at the bottom of the screen with the cursor positioned under the first character (“E”). This is a basic search, which is described in Section 7.1.

Suppose that you have the words “Executive Summary” in your table of contents so that the word processing system actually found this particular occurrence. As you don’t want to make

any changes to the table of contents, you can tell the system to search for the next occurrence of “Executive Summary.” This is a continued search, which is also described in Section 7.1.

You can also search for a particular phrase and replace it with another by pressing just two keys. For example, you could search for “Summary” and replace it with “Overview.” After you find “Summary” the word processing system gives you the opportunity to verify whether you really want to replace it. If you don’t (perhaps the system located “Summary” in “Summary of Results” instead of in “Executive Summary”), you can proceed to the next occurrence of “Summary.” Searching and replacing is described in Section 7.2.

The gold SRCH, CONT SRCH, and CONT SRCH & SEL keys are used for all types of searching.

7.1 BASIC AND CONTINUED SEARCHING

The basic searching and continue searching procedure is:

1. Press the gold and the SRCH keys. The message

ENTER PHRASE:

will be displayed on the screen.

2. Type the phrase that you want to locate.

3. Press either the ADVANCE (mini keyboard) or the RETURN (main keyboard) key to search forwards, the BACK UP (mini keyboard) key to search backwards. After a pause, the cursor will be positioned underneath the first character in the phrase. If no match is found, the system will buzz and the cursor will be positioned at the bottom of the document (for a forward search, at the top for a backward search).

4. To search for another occurrence of the same phrase, press the gold and the CONT SRCH keys. The search will continue in the same direction as you specified in step 3.

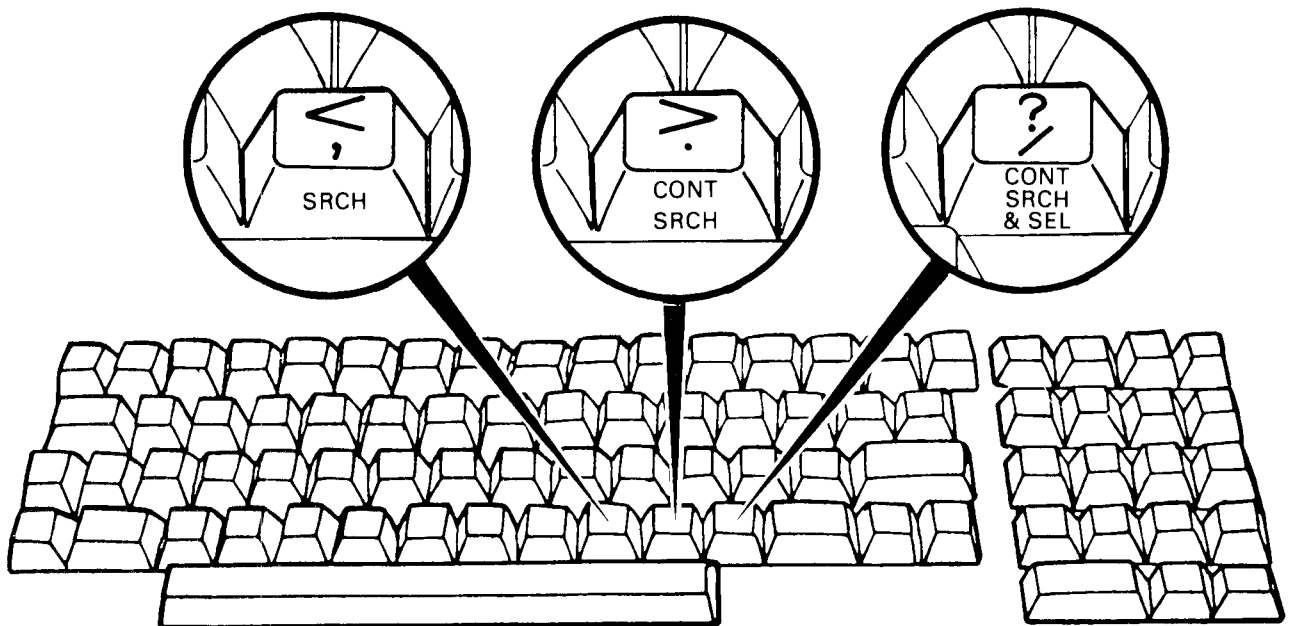

MK-0089

Figure 7-1 Main Keyboard SRCH, CONT SRCH, CONT SRCH & SEL Keys

You can cancel a search by pressing the gold and the HALT keys. This is useful if: (1) you have a large document, (2) the cursor is located near the beginning, (3) you initiate a search for a particular phrase, and then (4) you realize the document doesn't contain that phrase. Instead of wasting time while the word processing system searches for your nonexistent phrase, cancel the search. Just press the gold and the HALT keys.

7.1.1 Searching Qualifications

The phrase to be searched for is subject to the following qualifications:

1. **Size.** The phrase may not be longer than 50 characters.
2. **Contents.** The phrase may contain only letters, numbers, spaces, or punctuation and other special marks. You cannot search for tabs or centering marks. If you try, the system buzzes and waits for you to continue typing the phrase. You cannot search for a hard return because the system starts searching as soon as you press the RETURN key.
3. **Upper versus lower case.** If you type the phrase in lower case, the word processing system will find that same phrase if it's typed in either upper or lower case. However, if you type the phrase (or any part) in upper case, the word processing system will stop the cursor only where it finds an exact upper case match.

For example, suppose you are typing directions for operating electric grass shears. Your document contains several occurrences of the instruction "Push the ON button" except that sometimes it's spelled ON, sometimes On, and sometimes on. You want to find every place that the name of

the button is mentioned. Therefore, search for the phrase "on" to have the word processing system match any spelling. (If you type "On" it will match either "On" or "ON." If you type "ON" it will match only the exact upper case spelling.)

7.1.2 Direction Reversal

The direction of a search reverses when the cursor stops at either the top or bottom of a document (because no match was found). This means if you continue the search, the word processing system will look for a match in the direction opposite from that which you originally specified.

7.2 SEARCHING AND REPLACING

You can search for a phrase and possibly replace it with another. Why "possibly"? Because the word processing system gives you the option of deciding whether you really want to replace it. For example, suppose you've just typed what you thought was section 3 of a report. All your subsection headings, figure and table titles, and cross-references use the number 3. You find out that the report has been reorganized so that section 3 is now 4. With the word processing system the problem is easy to correct. You can search for "3" and inspect each occurrence before replacing it with "4." In this way you can avoid changing too much, such as the "3" in "September 3, 1977," for example.

To search and replace, follow these steps:

1. **Press the SEL key, type the replacement phrase, and then press the CUT key.** This action stores the replacement phrase in the word processing system's paste area (and removes it from your document).
2. **Press the gold and the SRCH keys, type the phrase you want replaced, and press the gold and the CONT SRCH & SEL keys.** This

action initiates a forward search. A select mark (white square) will be positioned under the first character in the next occurrence of the phrase (provided a match was found) and the cursor will be positioned under the last character.

3. **Press the gold and the REPLC keys** to replace the phrase. The selected phrase will

automatically be removed and replaced with what you put into the paste area. If you do not wish to replace this occurrence of the phrase, just press the gold and the CONT SRCH & SEL keys to search for the next occurrence.

You may repeat step 3 as many times as necessary.

CHAPTER 8 HIGHLIGHTING TEXT: CENTERING, UNDERLINING, BOLDFACING AND CAPITALIZATION

The word processing system has four features that let you highlight, or add emphasis to, your text.

1. **Centering.** You can automatically center a line by pressing just two keys. Word processing centering is much faster than centering on an ordinary typewriter because you don't have to count the number of letters, halve that number, and then backspace. See Section 8.1 for details.
2. **Underlining.** You can underline at the same time you type (faster than on an ordinary

typewriter) in addition to underlining after typing. See Section 8.2 for details.

3. **Boldfacing.** You can print portions of your document extra dark (struck three times) to add **emphasis to certain words**. See Section 8.2 for details.
4. **Capitalization.** Not only can you capitalize original text, but you can change text that is already typed from lower to upper case (or vice versa) just by pressing a few keys. See Section 8.3 for details.

8.1 CENTERING

You can have the word processing system center a line of text by using the gold and the CENTR keys.

Type the line to be centered and press the gold and the CENTR keys. To center a line that is already typed, move the cursor to the end of the line and press the gold and the CENTR keys.

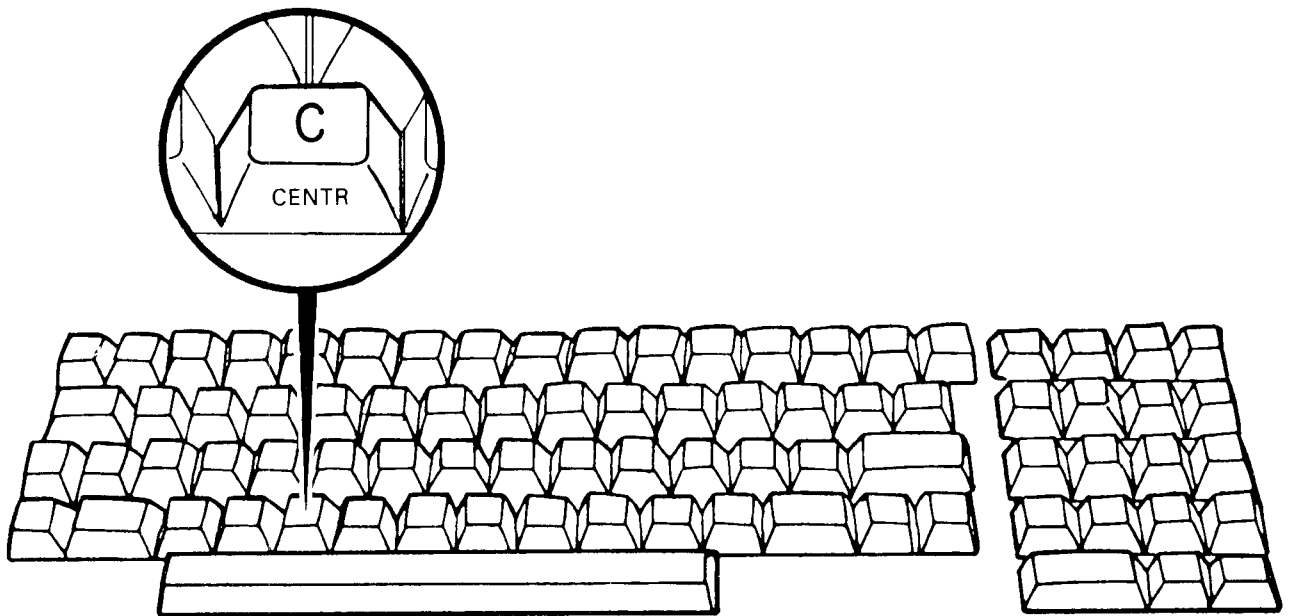

MK-0090

Figure 8-1 Main Keyboard CENTR Key

Here is an example of the procedure to center text:

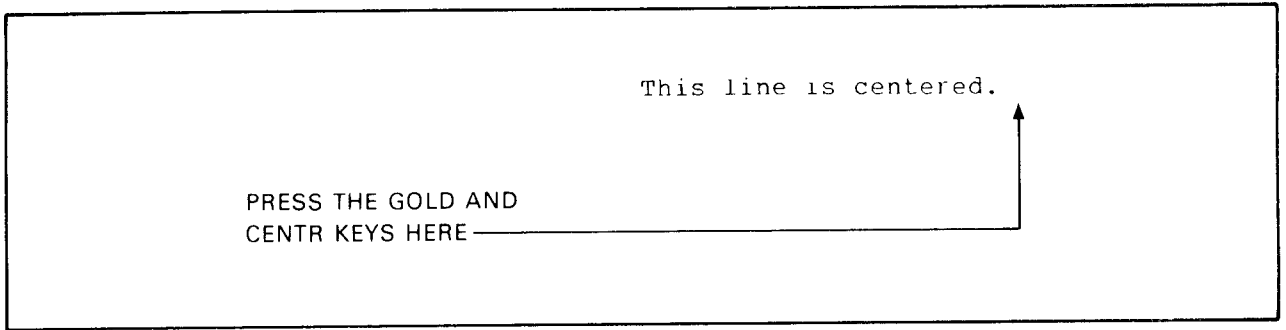

MK-0094

Figure 8-2 Example of Centering Text

Here is what the word processing system does when you center a line:

1. Determines in what typing position the line should start and automatically places it there.
2. Inserts a centering mark at the end of the centered line. This mark occupies one typing position yet is neither displayed on the

screen nor printed. It can be displayed on the screen only when text is viewed (see Section 8.1.2).

3. Moves the cursor to the beginning of the next line.

To remove a centering mark, position the cursor immediately after the last (visible) character of the centered line and press the DEL CHAR key.

8.1.1 Changing the Centering Point

Unless you direct the word processing system otherwise, a line is automatically centered between the left and right margins. To specify a different centering point, or typing position, on which text will be entered, follow these steps:

1. Press the gold and the RULER keys to display the ruler.
2. Advance the cursor to the desired centering position and type the letter C. You can have

only one centering point in a ruler. If you type the letter C a second time, the word processing system automatically removes the first.

3. Press the RETURN key to clear the ruler display and embed the ruler back into the document.

Here is an example of a line typed with an off-center centering point in effect:

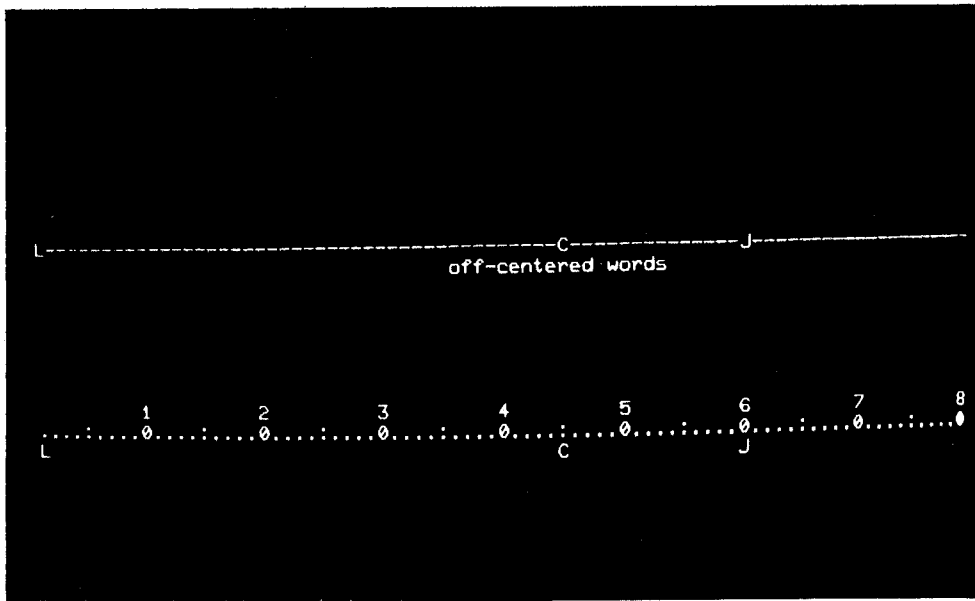

8920-28R2-A0096

Figure 8-3 Example of a User-Specified Centering Point

8.1.2 Determining Whether Text Is Centered

Sometimes you might have a typed line that appears centered on the screen or in a printed document, but you're not really certain whether it was typed with spaces, tabbed, or centered with the gold CENTR key. To determine how the line was typed, you must view the text by

pressing the gold and the VIEW keys (see Appendix D). When viewed, the end of a centered line is marked with a `␣` symbol.

Here is an example of a screen display for viewing a centered line:

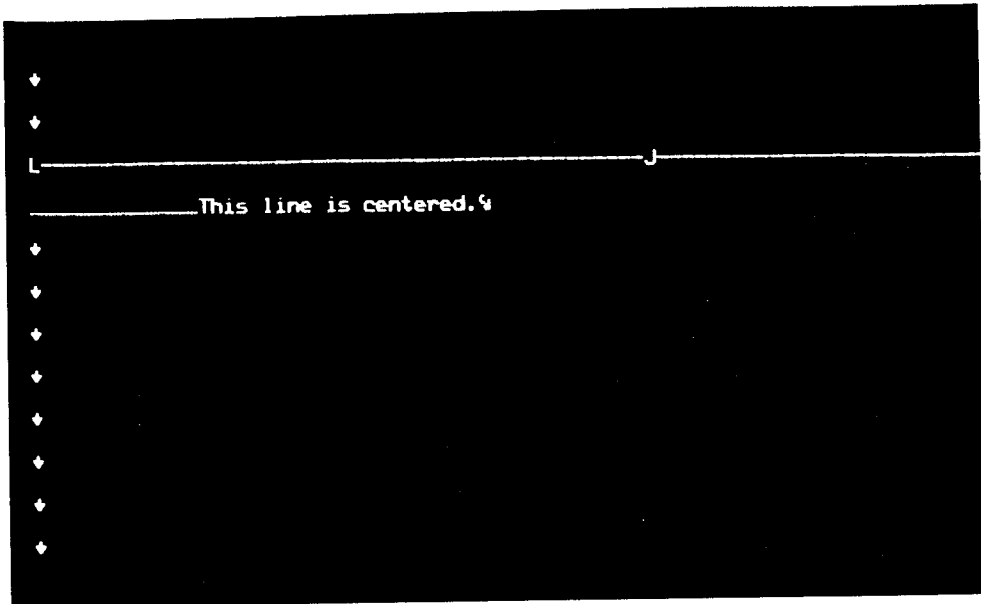

9113-26R2-A0095

Figure 8-4 Example of Viewing Centered Text

8.2 UNDERLINING AND BOLDFACING

The mini keyboard UNDER LINE and BOLD keys can be used to highlight text.

You can use these keys along with the SEL key to underline or boldface text at the same time as you type it (see Section 8.2.1). You can use these keys along with either the SEL key or the mini keyboard blue grammatical keys to add highlighting to text after it is typed (see Section 8.2.2). You can also use these keys along with the gold key to remove highlighting (see Section 8.4).

8.2.1 Underlining or Boldfacing While Typing

To underline or boldface text at the same time as you type:

1. **Press the SEL key.** A select mark, or white square, will appear on the screen.
2. **Type the desired text.** This will be displayed right after the select mark (dropped down one line on the screen).
3. **Press the UNDER LINE or BOLD key.** The select mark will be removed and what you just typed will again be displayed on the same line level as your previous typing.

Underlined or boldfaced text is marked for such highlighting but is displayed on the screen without the highlighting (see Section 8.2.3 for determining whether text is underlined or boldfaced).

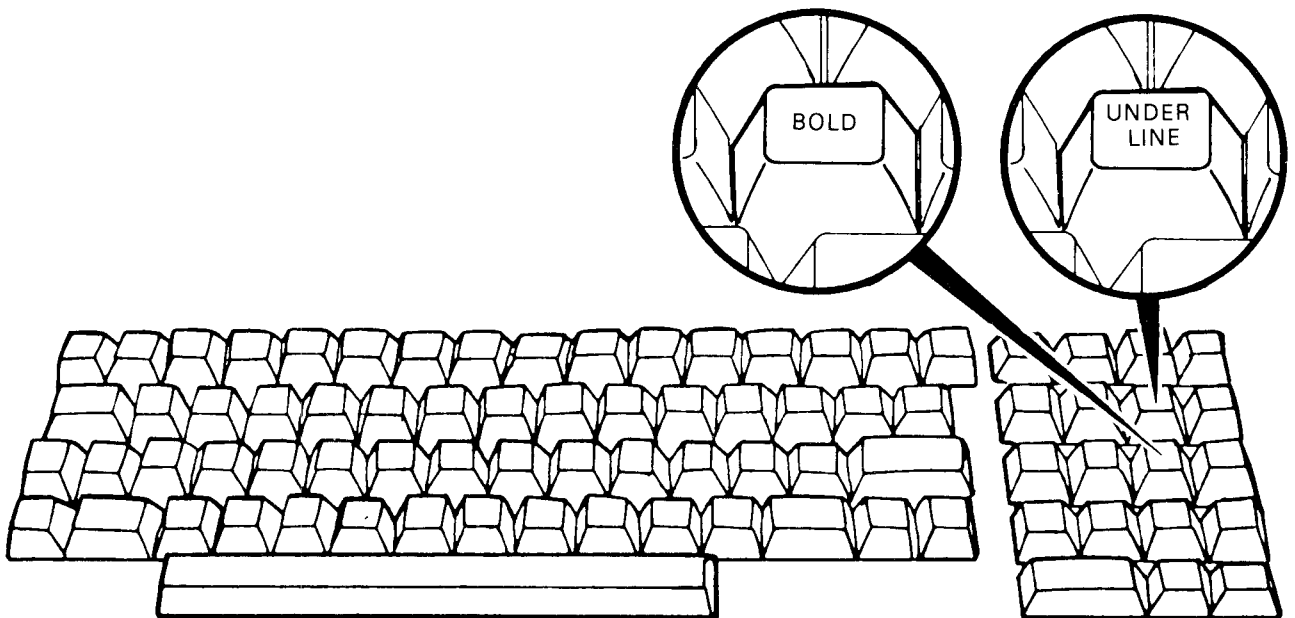

MK-0091

Figure 8-5 Mini Keyboard BOLD and UNDERLINE Keys

When steps 1 - 3 are used to underline text, both words and the spaces between them are underlined. Refer to Section 8.2.4.2 for how to underline only the words.

8.2.2 Underlining or Boldfacing After Typing

You can underline or boldface any portion of text after it has been typed by moving the cursor to the beginning, pressing the SEL key, moving the cursor to the character or space right after the end, and pressing the UNDER LINE or BOLD key. (If you press SEL in the wrong place, just press it again and the select mark will automatically be removed from the screen.) This method underlines the words plus the spaces between them.

For example, suppose you type

This is an important sentence.

and then decide you want the words "important sentence" underlined, for emphasis. Just move the cursor to the beginning of "important," press the SEL key, move the cursor to immediately after the period, and press the UNDER LINE key. The result will look like this:

This is an important sentence.

You can also use the UNDER LINE and BOLD keys with the blue mini keyboard grammatical keys. This method underlines only words and not the spaces between them.

1. **Position the cursor at the beginning of the text and press either the UNDER LINE or BOLD key.** This action "turns on" highlighting so that all text over which you move the cursor will be highlighted.
2. **Press any blue grammatical key (WOORD, LINE, SENT, TAB POS, PARA, PAGE, or <>),** until you have moved through the desired amount of text.
3. **Press either the ADVANCE or BACK UP key** to "turn off" the highlighting (and move the cursor one position forward or backward). If you don't turn off highlighting and proceed to move the cursor forward, all the rest of your text will also be highlighted.

Underlining and boldfacing are also turned off when you do one of the following: (1) type additional text, (2) use the mini keyboard DEL CHAR, DEL WORD, SWAP, or PASTE key, or (3) use one of the main keyboard rubout keys (RUB CHAR OUT, RUB WORD OUT, RUB LINE OUT, or RUB SENT OUT).

Another way to highlight text that is already typed is to position the cursor at the beginning and then press the UNDER LINE or BOLD key while holding down the REPEAT key. This method also turns on highlighting. Be sure to turn it off when you are through as described above.

8.2.3 Determining Whether Text is Underlined or Boldfaced

Text marked for underlining or boldfacing is displayed on the screen like ordinary text. To determine whether text is underlined or boldfaced, you must view it by pressing the gold and the

VIEW keys (see Appendix D). When viewed, an underscore character appears under text marked for underlining, a * character under text marked for boldfacing, and an = character under text marked for both underlining and bold-facing.

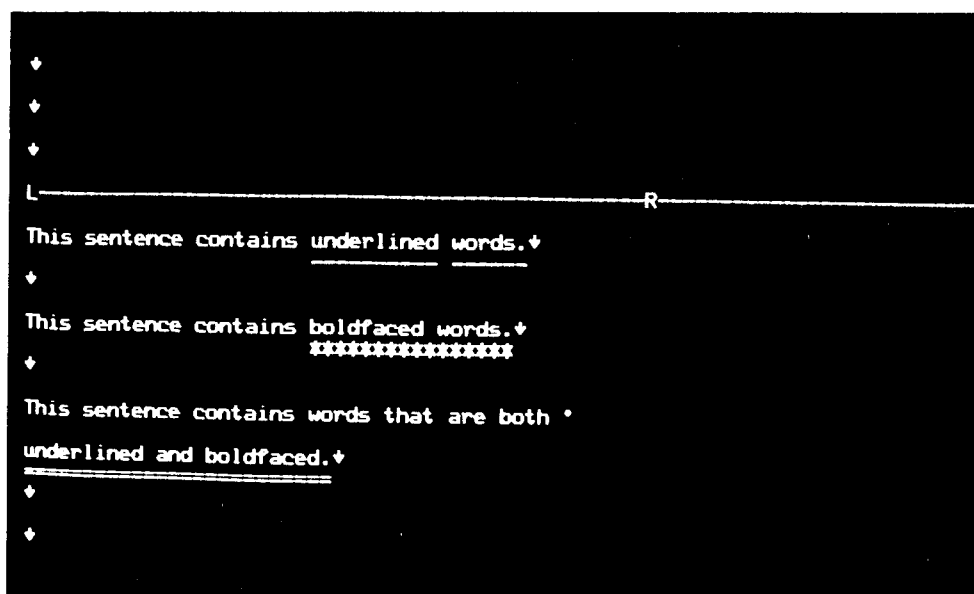

9113-28R2-A0097

Figure 8-6 Example of Viewing Underlined and Boldfaced Text

8.2.4 Effect of Spaces on Underlining

The word processing system gives you the choice of underlining words and the spaces between them or just the words themselves. For example, you can underline these few words or the entire rest of this sentence.

8.2.4.1 Underlining Words and Spaces – There are three different ways to underline words and the spaces between them.

1. For original typing or already-typed text: Press the SEL key at the beginning of the

group of words, either type the text or move the cursor to the character or space right after the end (if the text is already typed), and press the UNDER LINE key.

2. For already-typed text: Press the UNDER LINE key and then any blue grammatical key (LINE, SENT, TAB POS, PARA, PAGE, or <>) except WORD. When you have moved the cursor through all desired text, press either the ADVANCE or BACK UP key to turn off underlining.
3. For already-typed text: Press the UNDER LINE key and hold down the REPEAT key (main keyboard, bottom right). Release the two keys after you have moved the cursor through the desired amount of text. Press either the ADVANCE or BACK UP key to turn off underlining.

8.2.4.2 Underlining Only Words – To underline words and not spaces, press the UNDER LINE

key and then the WORD key as many times as necessary. You can use this method only with already-typed text. You cannot underline words and not the spaces between them as you type text.

When you use this method, tabbed spaces will be underlined but typed spaces (inserted by pressing the space bar) will not.

8.2.4.3 Effect of Right Margin on Underlining – If your text is typed with a justified right margin (letter J used in the ruler), the way you underline may affect the appearance of a line printed on a letter quality printer.

1. If a complete line including spaces is underlined, the word processing system will justify the line by adding space between both characters and words AFTER the line is underlined. This action may cause the line to be stretched, thereby breaking the underlining.

These few lines are completely underlined and are typed with a justified right margin. Notice how the underlining is broken.

2. If only the words and not the spaces are underlined or if only a partial line is underlined, the word processing system will justify by adding space only between words. Then none of the underlining will be broken.

Only the words and not the spaces in these few lines are underlined. They are typed with a justified right margin. Notice how the underlining looks.

However, if a line is completely underlined and is typed with a ragged right margin (letter R used in the ruler), the underlining will not be stretched or broken.

These few lines are completely under-lined and are typed with a ragged right margin. Notice that the underlining is solid.

8.3 CAPITALIZATION

To capitalize text as you type, press either the CAPS LOCK or the SHIFT key, type the text, and press the same key again to resume typing in lower case. You can also capitalize by pressing the mini keyboard SEL key, typing the text, and then pressing the mini keyboard UPPER CASE key.

To capitalize already-typed text, move the cursor to the beginning, press the SEL key, move the cursor to the character or space right after the end, and press the UPPER CASE key.

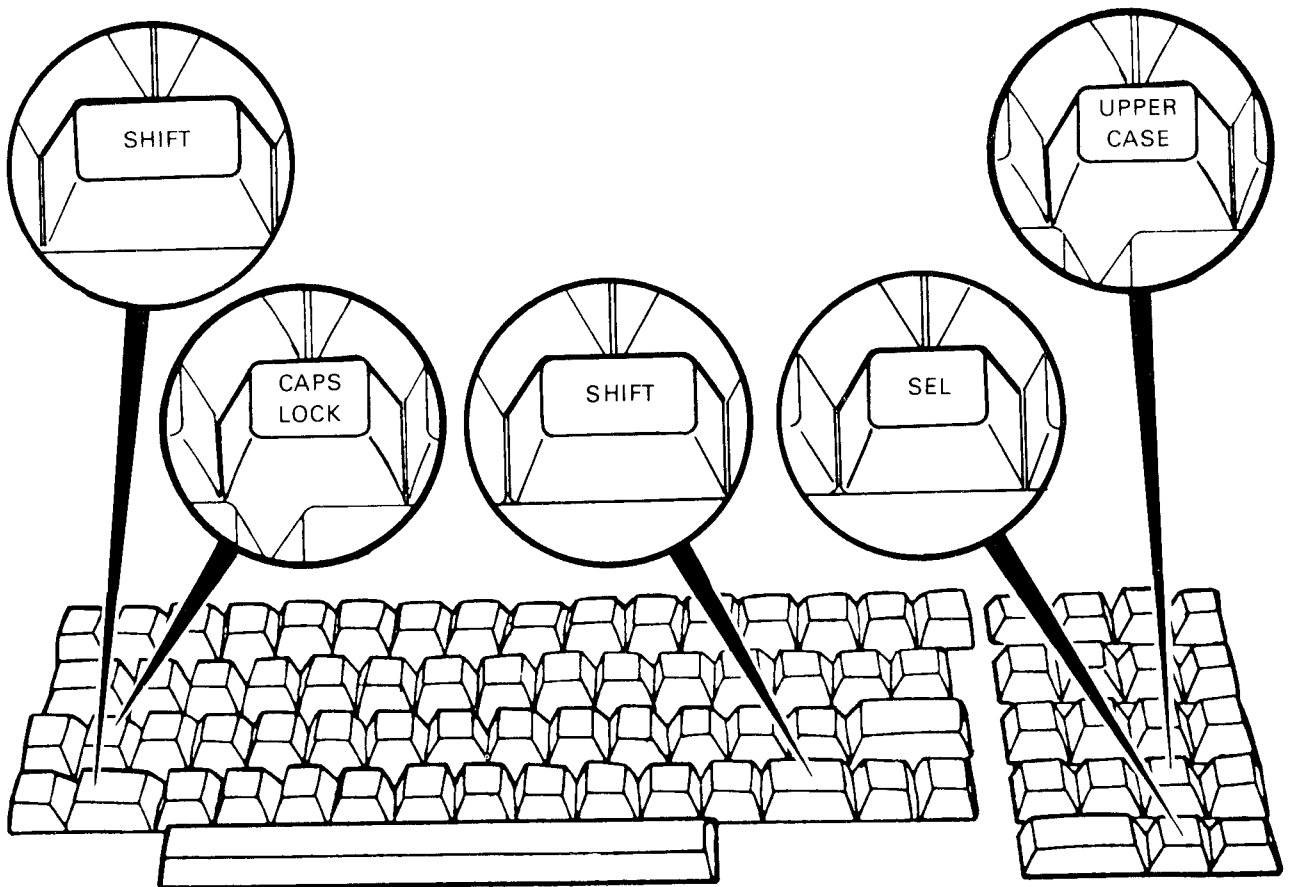

MK-0092

Figure 8-7 Main Keyboard SHIFT and CAPS LOCK Keys, Mini Keyboard SEL and UPPER CASE Keys

8.4 REMOVING UNDERLINING, BOLD-FACING AND CAPITALIZATION

You can remove underlining, boldfacing, or capitalization if necessary. Move the cursor to the beginning of the text to be changed, press the mini keyboard SEL key, position the cursor at the end, and press the gold and the UNDERLINE, BOLD, or UPPER CASE key. Nothing

will happen if you attempt to remove underlining, boldfacing, or capitalization when your text is not marked for such highlighting.

For example, suppose you accidentally type an entire name in upper case instead of just the first initial. To fix it, follow these steps:

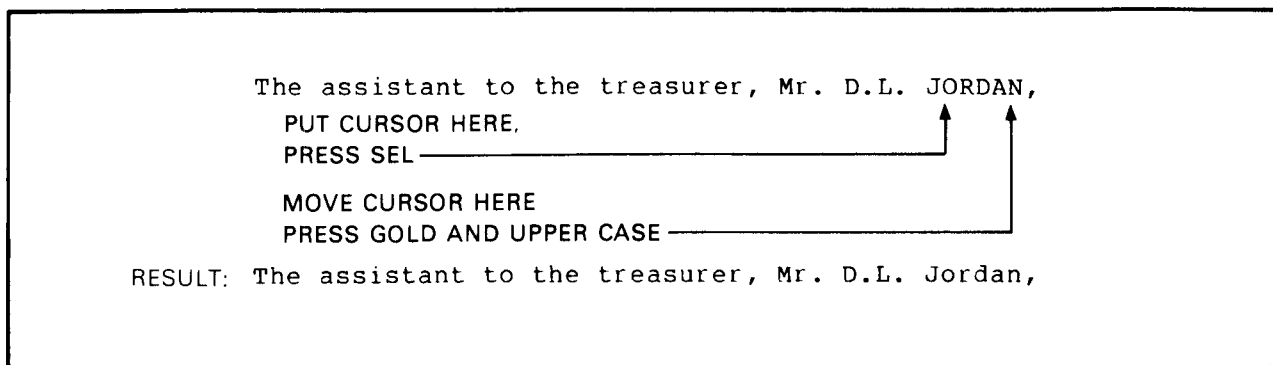

MK-0093

Figure 8-8 Example of Changing Uppercase Text to Lowercase